

# I1 BODY

OUTLINE -----	I1 - 1
CONSTRUCTION AND OPERATION -----	I1 - 2
SAFETY PERFORMANCE -----	I1 - 2
BODY SHELL -----	I1 - 5
AERODYNAMIC PERFORMANCE -----	I1 - 7
OTHER BODY CONSTRUCTION -----	I1 - 7

## 1 OUTLINE

1.The vehicle features compatibility body frame structure to enhance passive safety, offering protection in all directions in a collision with a vehicle weighing more.

### **NOTE**

- **Compatibility body:** This refers to the body structure that is designed to pursue compatibility in a collision between two vehicles of different weights and offer optimum protection for both vehicles, through an improvement in passive safety for the lighter vehicle and a reduction in aggressiveness of the heavier vehicle.

2.The vehicle features Total Advanced Function "TAF" to secure cabin space for survival in the event of a collision and to protect the occupants. "TAF" meets the Japan's passive safety standard (50 km/h frontal, side, and rear collisions) and the European passive safety standard (40% offset frontal collision at 56 km/h, side collision at 50 km/h). Moreover, Daihatsu Motor sets up our own stricter target levels to provide a highest level of protection for occupants in this class of the vehicles.

### **NOTE**

- "TAF"(Total Advanced Function body) refers to a collision safety body that has been evolved totally.

3.High-tension steel sheets have been employed on principal structure, thereby realizing a body that features light weight and high rigidity.

## 2 CONSTRUCTION AND OPERATION

### 2-1 SAFETY PERFORMANCE

#### 2-1-1 FRONT ENERGY ABSORPTION CONSTRUCTION

The vehicle features body frame structure that efficiently dissipates energy in a frontal impact from the front side member front to the front side member rear, front body pillar, locker panel, side door belt line, etc., to secure cabin space for occupant protection.

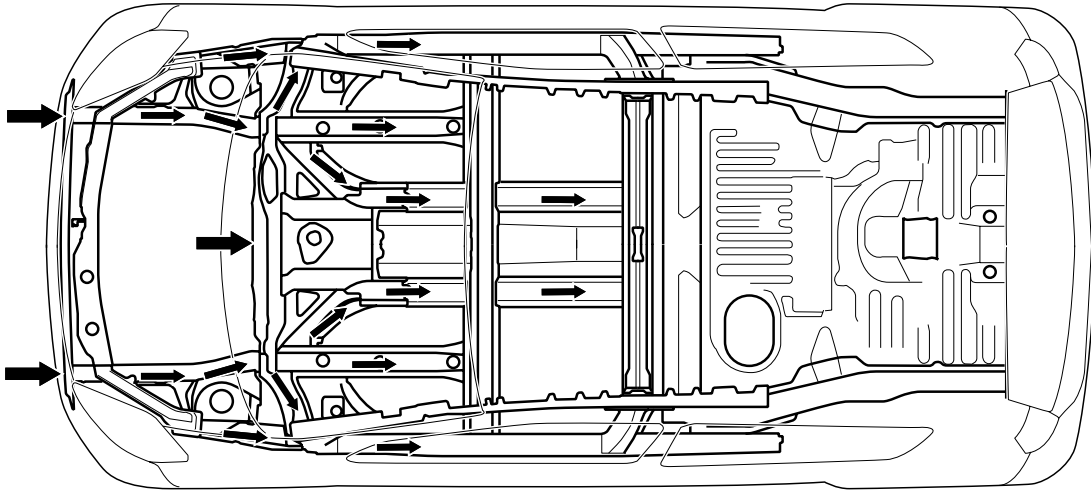

<Top view>

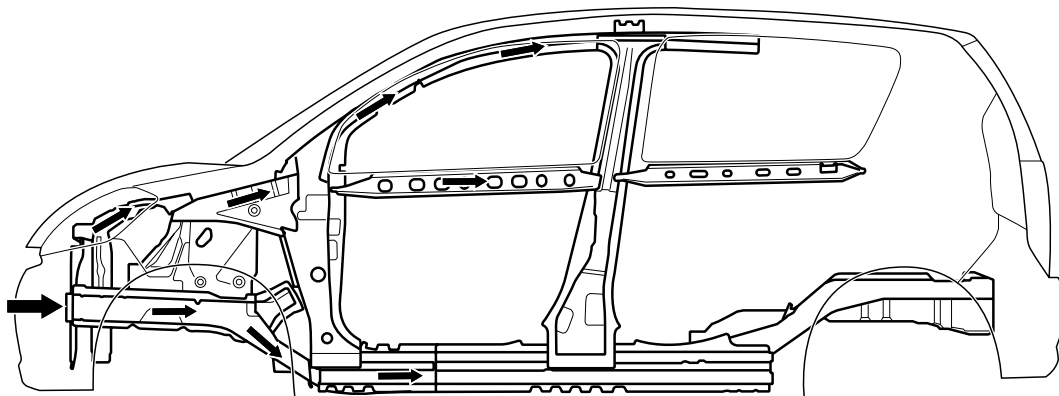

<Side view>

## 2-1-2 SIDE ENERGY ABSORPTION CONSTRUCTION

The collision energy from the side can be dispersed effectively to the center body pillars, roof side rails and locker panels. Consequently, the passenger compartment space for protecting occupants has been assured.

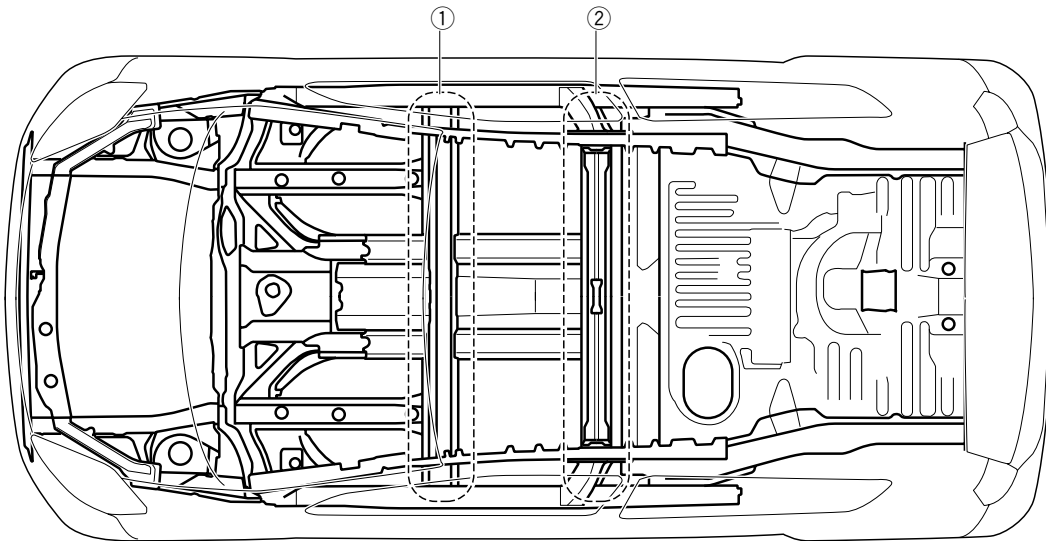

< Top view >

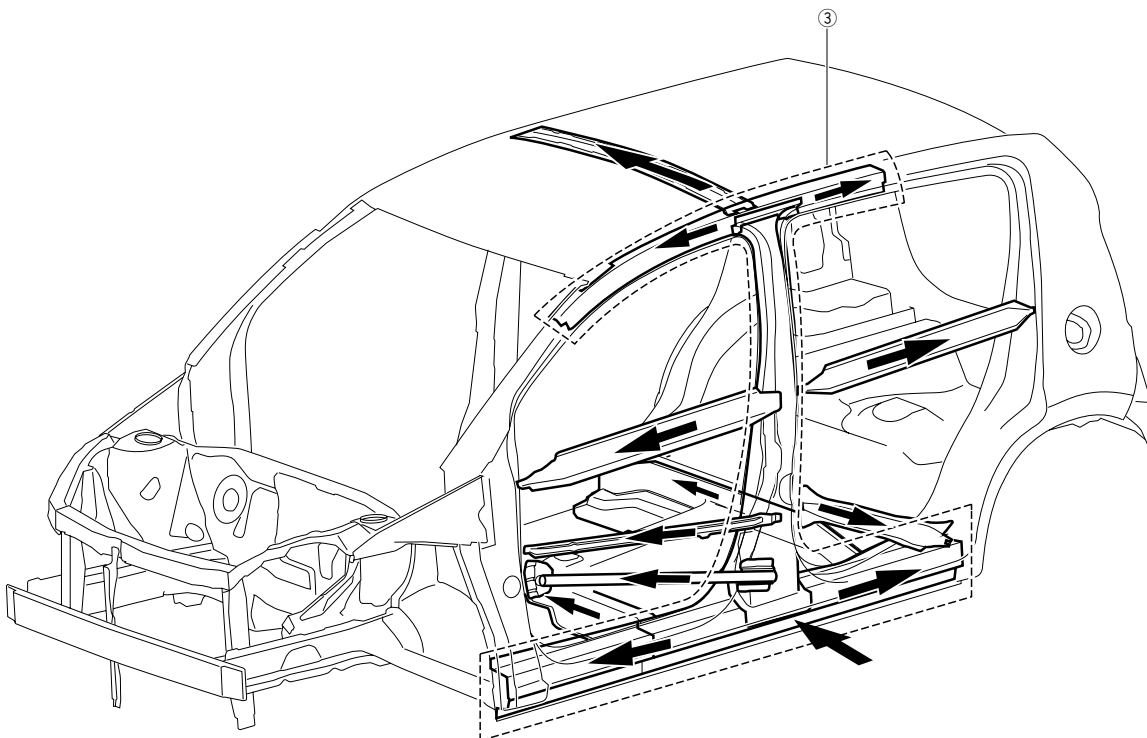

T11B1502ES40

①	The front seat body mounting area (the joint section of the front floor cross member to the front floor tunnel, and the joint section of the front floor cross member to the rocker inner panel) has been reinforced in order to secure the cabin space for survival of the occupants in the event of a collision.
②	The rear floor cross member has been straightened to absorb side impact forces.
③	The bearing forces of the rocker panel, center pillar, and roof side rail are optimized to reduce the amount of body deformation and to secure survival space for occupants.

**2-1-3 PEDESTRIAN INJURY REDUCTION BODY CONSTRUCTION**

- 1.The vehicle features body structure to reduce the injuries to pedestrians in the event of a collision involving a pedestrian.
- 2.Regarding the hood panel, the thickness of the inner panel is reduced and the frame is arranged longitudinally, while allowing space to the components in the engine compartment so that the injuries to pedestrians can be reduced.
- 3.A crushable structure has been adopted for the cowl panel to reduce the injuries to pedestrians.
- 4.In order to reduce injury to the pedestrian legs, an impact energy absorbing section is provided on the upper reinforcement of the front bumper and a pedestrian leg-sweeping reinforcement is provided at the lower section.

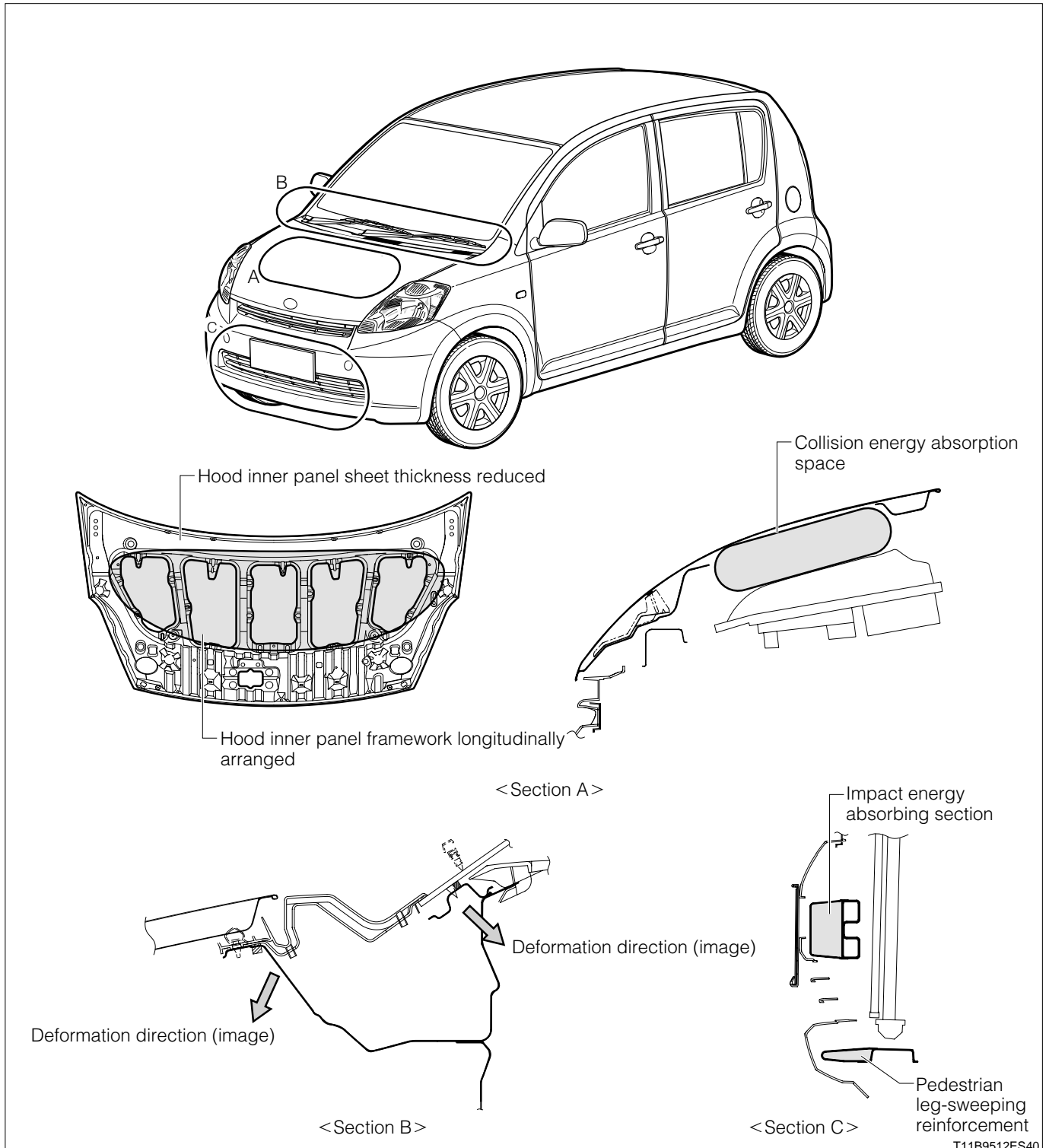

## 2-2 BODY SHELL

### 2-2-1 PARTS WHERE HIGH-TENSILE STEEL SHEETS ARE USED

High-tension steel sheets that features light weight and dent-resistance for local external forces have been employed at various sections so that weight reduction and high rigidity may be attained.

#### NOTE

- Dent-resistance properties: When external forces (e.g. finger pressure during door opening or closing periods or flying stones) are locally applied to outer panels of motor vehicles, very small dents may be formed (Dentability). Properties that have resistance to these dents are called dent-resistance properties.

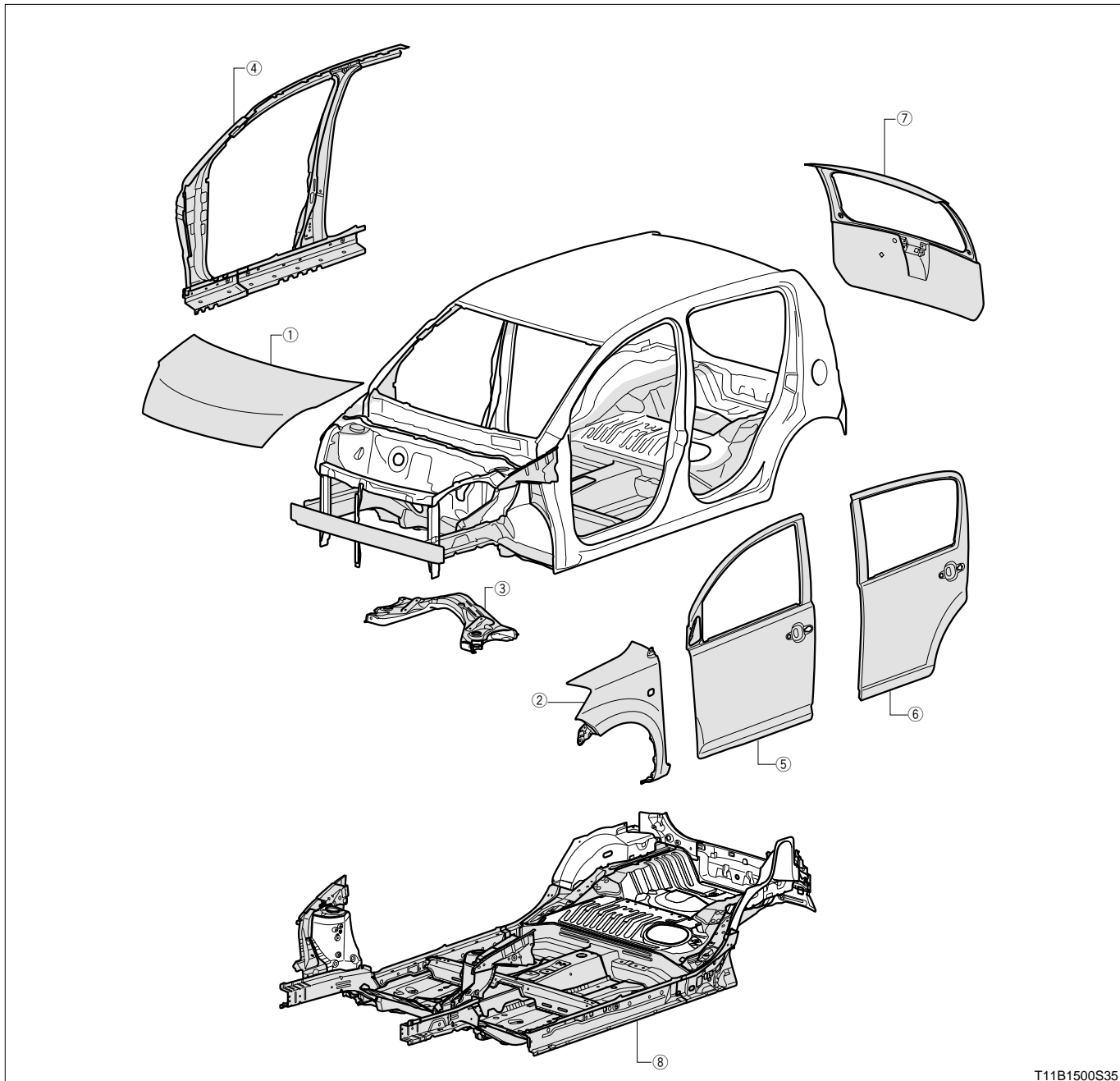

T11B1500S35

	Applicable components		Applicable components
①	Hood panel	⑤	Front door outside panel RH/LH
②	Front fender panel	⑥	Rear door outside panel RH/LH
③	Suspension Member	⑦	Back door outside panel
④	Reinforcement around front door	⑧	Front floor side member

### 2-2-2 PARTS WHERE ANTI-RUST STEEL SHEETS ARE USED

For better anti-rust effect, the corrosion-resistant steel plate has been adopted for components that require more stringent conditions concerning rust formation.

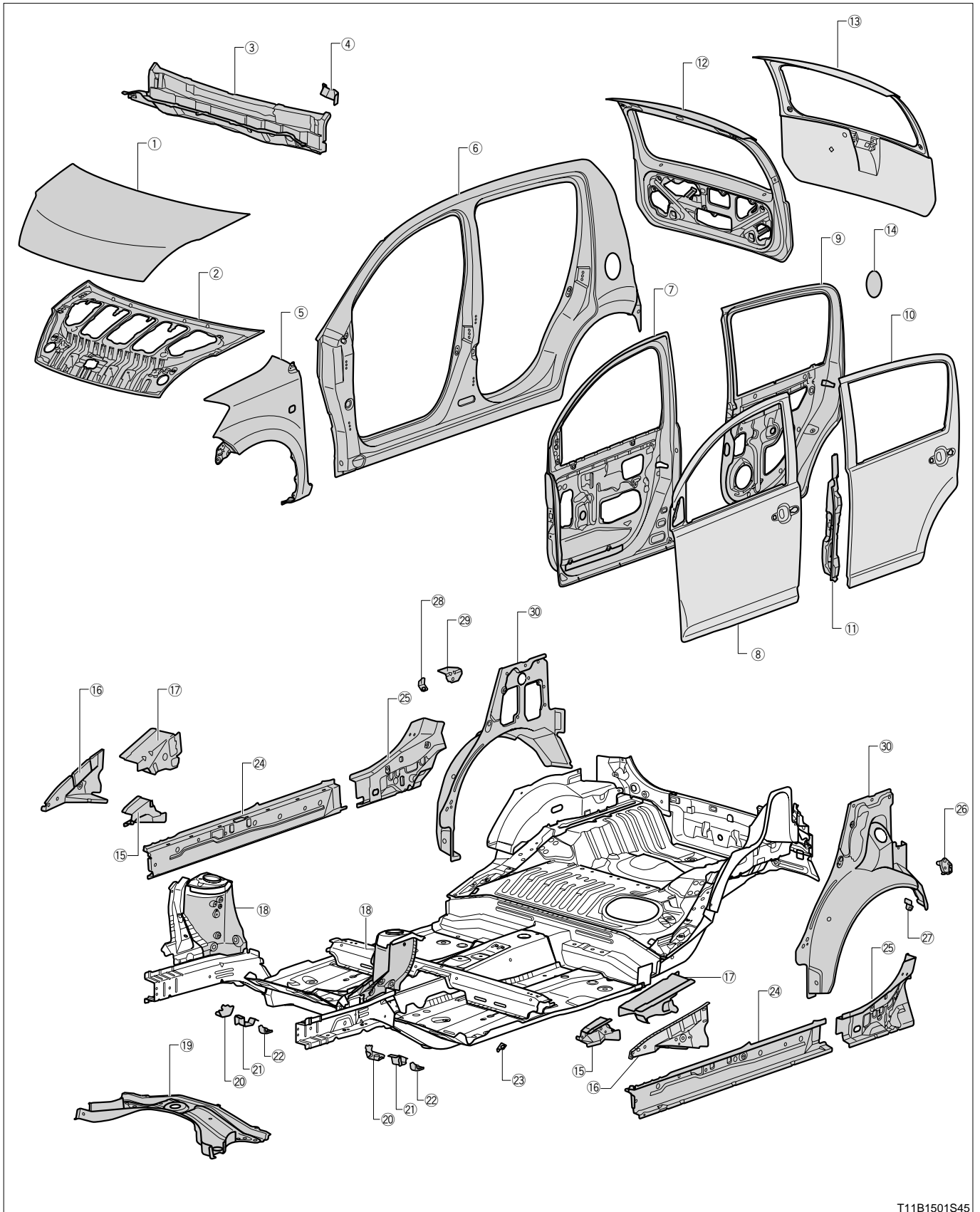

	Part name		Part name
①	Hood panel	⑩	Cowl top side panel RH/LH
②	Hood inner panel	⑪	Cowl top side inner panel RH/LH
③	Cowl top inner panel	⑫	Front fender apron RH/LH
④	Wiper shaft side retainer	⑬	Front suspension lower
⑤	Front fender panel RH/LH	⑭	Brake actuator mounting reinforcement No.1 RH/LH
⑥	Side outer panel RH/LH	⑮	Front suspension member mounting bracket RH/LH
⑦	Front door inside panel RH/LH	⑯	Suspension member spacer reinforcement RH/LH
⑧	Front door outside panel RH/LH	⑰	Flexible hose bracket No.1
⑨	Rear door inside panel RH/LH	⑱	Floor side inner member RH/LH
⑩	Rear door outside panel RH/LH	⑲	Floor side inner rear member RH/LH
⑪	Rear door hinge side panel RH/LH	⑳	Parking brake cable guide bracket No.2 LH
⑫	Back door inside panel	㉑	Parking brake cable guide bracket No.4
⑬	Back door outside panel	㉒	Floor brake hose rear bracket RH
⑭	Fuel filler opening outer lid	㉓	Rear absorber mounting reinforcement
⑮	Front apron to cowl side upper member RH/LH	㉔	Quarter inner panel lower RH/LH

## 2-3 AERODYNAMIC PERFORMANCE

### 2-3-1 UNDERBODY AIR FLOW REGULATING ITEM

- 1.As for the front bumper of the aero-bumper equipped vehicles, its front end has been lowered to rectify the air stream under the floor so that the air resistance may be reduced.
- 2.The front bumper for the vehicle equipped with the standard bumper features the lip spoiler shape while lowering the front end to control under floor air stream and help reduce air resistance. (Figure below ①) Also the fender liner for the vehicle equipped with the standard-bumper features the spats-like shape at the front end lower to control air stream in front of the tires and help reduce air flow into the tires. (Figure below ②)

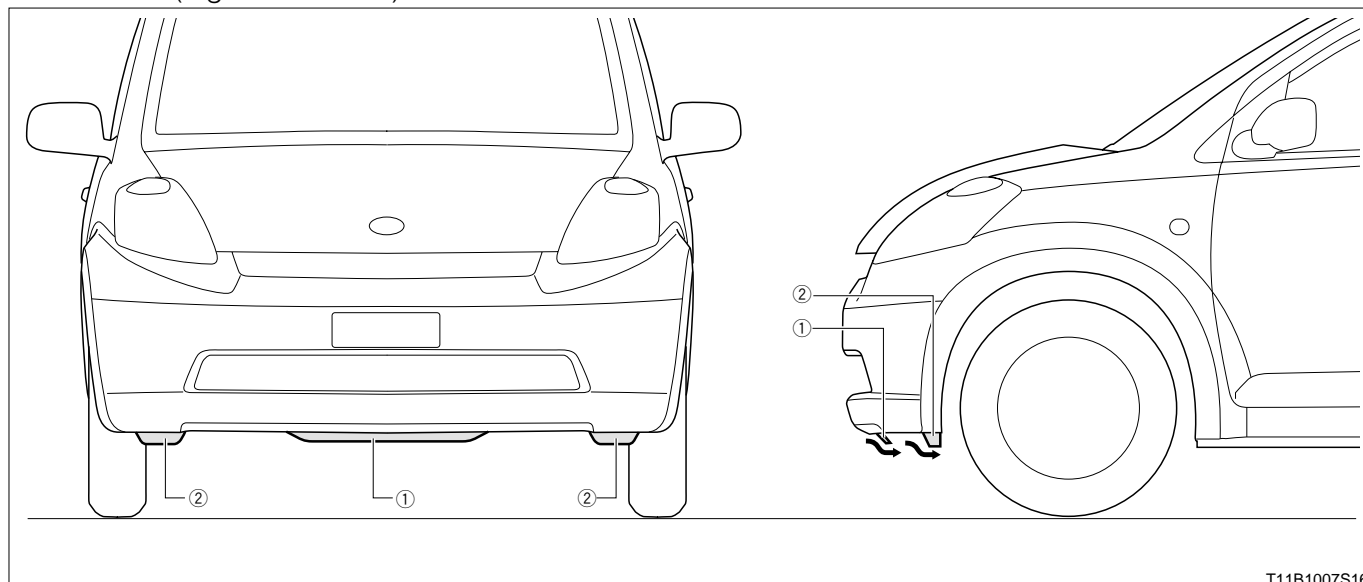

T11B1007S16

## 2-4 OTHER BODY CONSTRUCTION

### 2-4-1 MARK FACILITATING DISASSEMBLY

Dismantling improvement markings are placed on the large-sized parts such as the front bumper, door trim, deck side trim, and instrument panel. These markings help identify what to be removed and improve disassembly workability. This way, our efforts toward recycling can be expected to attract more attention from users.

