

HYDRAULIC CONTROL

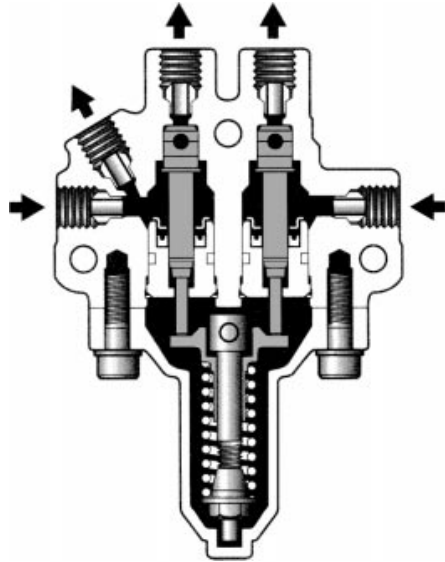

- Lesson Objectives**
1. Describe the purpose of a proportioning valve.
 2. Describe the purpose of a load sensing proportioning valve.
 3. Describe the function of the bypass valve in a LSPBV.
 4. Measure front and rear brake pressure using LSPV pressure gauge set.
 5. Adjust LSPBV rear brake pressure.

Hydraulic Control Valves

Hydraulic control valves regulate hydraulic pressure to the rear brakes to ensure efficient braking. Types of control valves used on Toyotas:

- Proportioning Valve.
- Proportioning and Bypass Valve.
- Double Proportioning Valve.
- Load Sensing Proportioning Valve.
- Load Sensing Proportioning and Bypass Valve.

Control of rear brake pressure is necessary because inertia, created when the brakes are applied, shifts vehicle weight toward the front wheels. Because the rear wheels have less weight during braking, they can lockup, causing the vehicle to lose traction and skid out of control.

The front of a front-engine vehicle is heavier than the rear, so when the brakes are applied, the vehicle's center of gravity tends to move forward because of inertia. This adds to the front load, and the rear load decreases as a result. With greater braking force, the center of gravity moves further forward and the rear load decreases even more.

Shifting Center of Gravity

When the brakes are applied, the vehicle's center of gravity tends to move forward reducing load at the rear wheels.

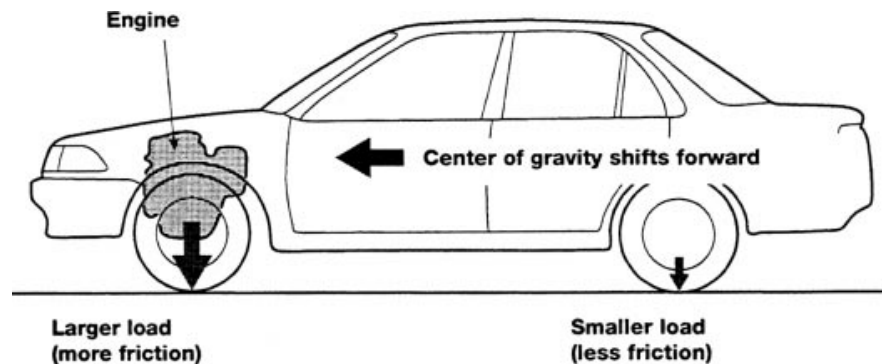

Assuming that the front and rear wheels exert an identical braking force in the above condition, the rear tires, which are subject to a smaller load, tend to lockup early. This will cause the rear tires to lose traction or skid.

When the tires skid, the friction between the tires and the road becomes extremely small, and the tires will fail to remain in sufficient contact with the road. Unless the vehicle is moving straight ahead, it will “fishtail”, which can be very dangerous.

The braking force of the rear tires must be reduced below that of front tires in order to prevent early lock-up. This is achieved by the proportioning valve (P. valve). It is designed to automatically reduce the hydraulic pressure for the rear wheel cylinders in proportion to hydraulic pressure from the master cylinder.

Proportioning Valve Location

The braking force of the rear tires must be reduced below that of front tires in order to prevent early lock-up.

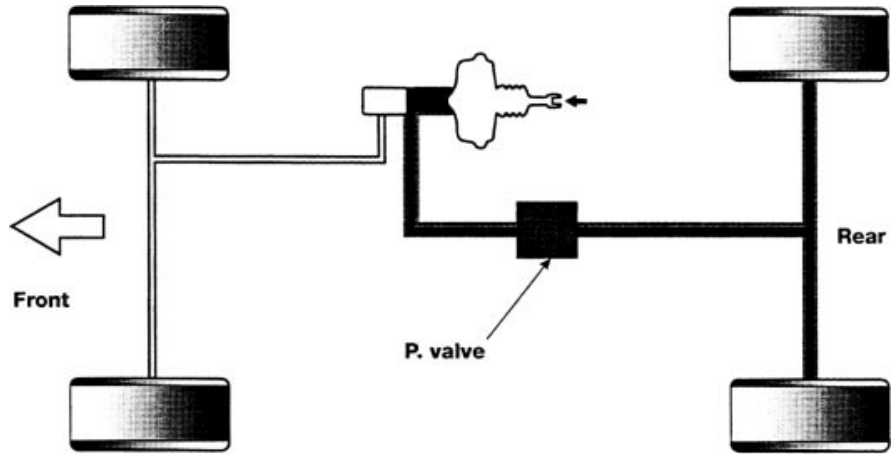

Hydraulic Pressure Curve

The graph below shows an ideal hydraulic pressure curve for the front and rear wheels (actual values vary from one vehicle model to another). The proportioning valve is designed to bring actual pressure curves as close to the ideal as technically possible.

Hydraulic Pressure Curve

The P-valve is designed to bring actual pressure curves as close to the ideal as technically possible.

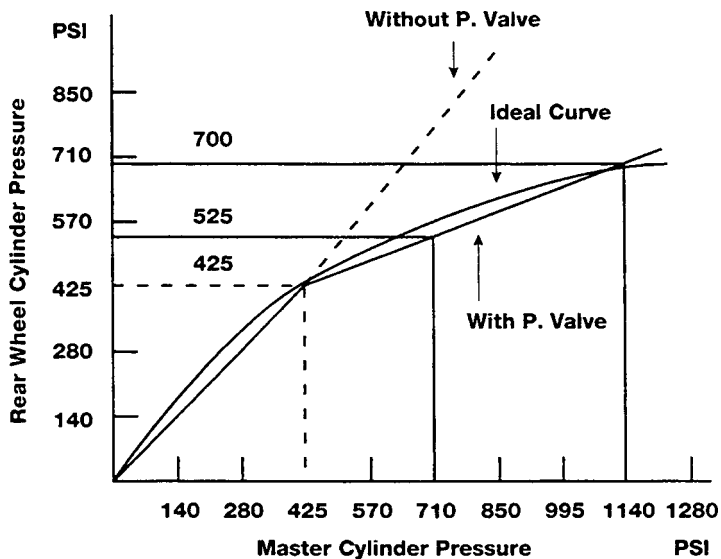

**Proportioning Valve
Operation**

The spring in the Proportioning valve holds the valve in the open position. During normal braking the brake fluid flows through the valve without any proportioning action. However, when heavier braking occurs, pressure on the wheel cylinder side of the proportioning valve pushes the valve against spring tension and closes the valve. This in effect reduces pressure to the rear brakes. As pressure increases on the master cylinder side, it lifts the valve, increasing pressure to the wheel cylinder side of the valve. As pressure increases on the wheel cylinder side of the valve, it seats again. This occurs in rapid succession as long as pressure from the master cylinder increases.

Proportioning Valve

Pressure on the rear cylinder side pushes the valve against spring tension and closes the valve.

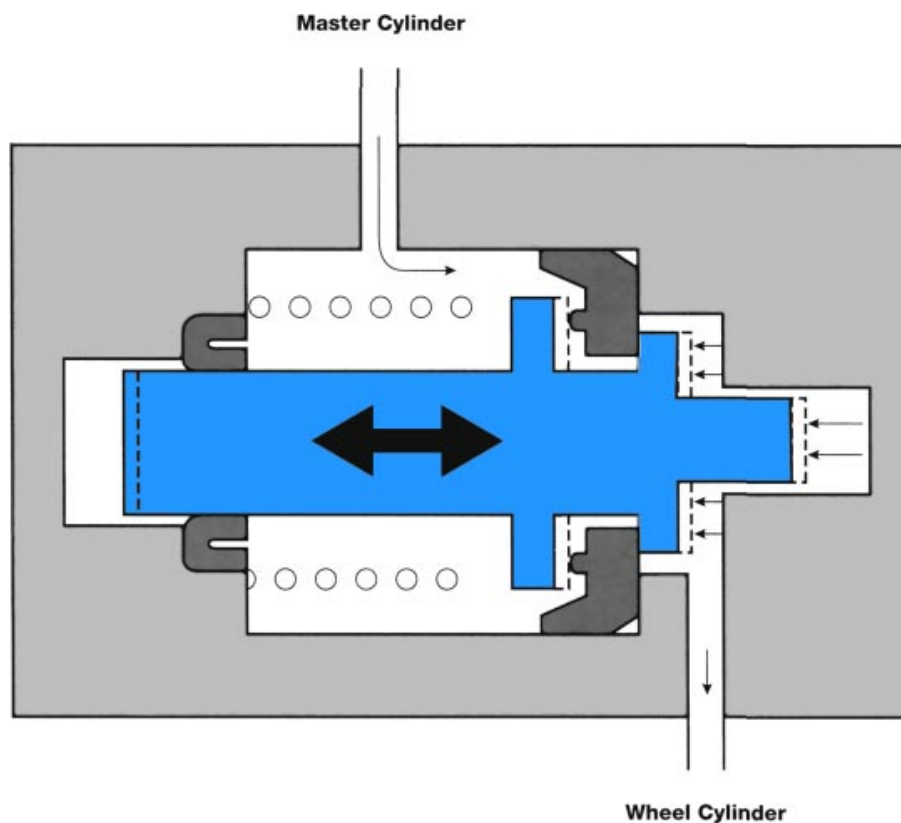

In order to release the pressure between the proportioning valve and the rear wheel cylinders, the valve seat floats as shown in the illustration. When the pressure from the master cylinder is released, the pressure difference on the valve seat causes it to be pushed away from its seated position on the valve body. This allows fluid to pass the valve seat and the brakes to release.

Proportioning Valve Brake Released

When the pressure from the master cylinder is released, the valve seat is pushed away from its seated position and allows fluid to pass.

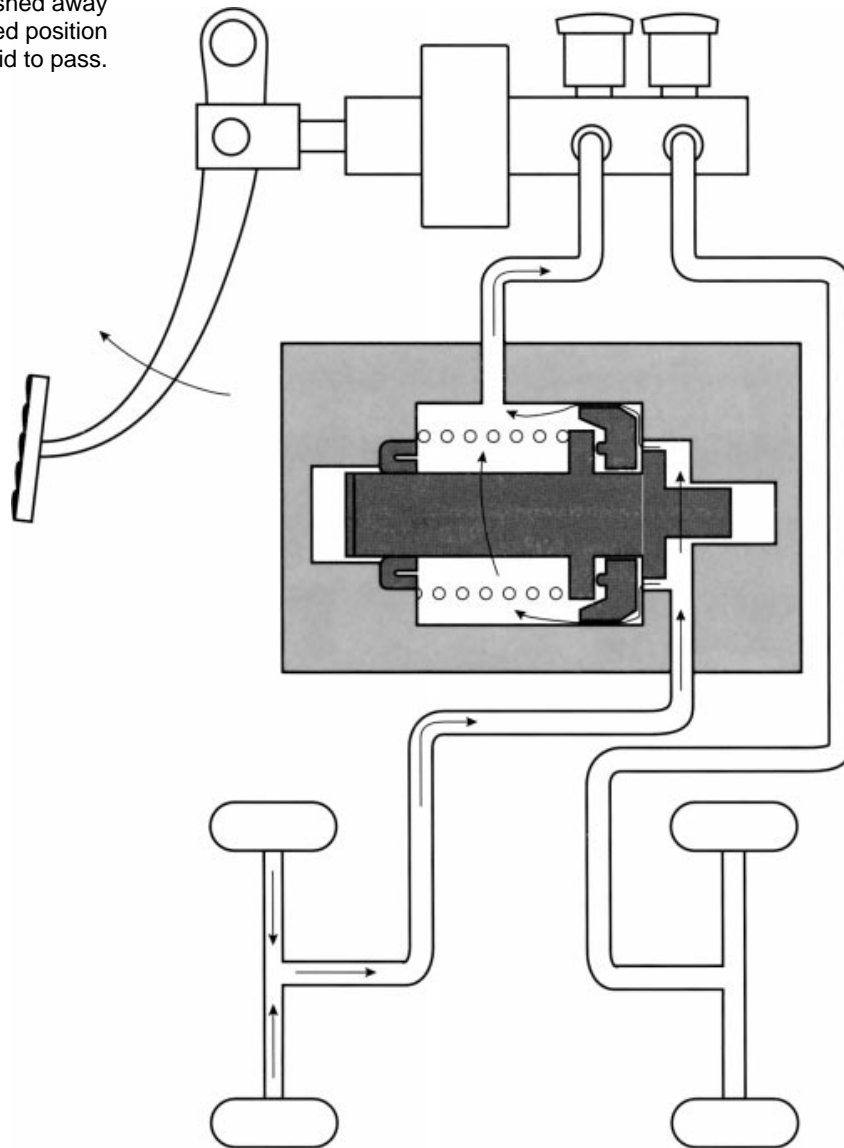

Proportioning and Bypass Valve Operation

The proportioning function of this valve is the same as that described on the previous pages however, a **Bypass Valve** is incorporated into the valve body. It ensures maximum braking pressure to the rear brakes when there is a loss of brake pressure in the front brake circuit.

The hydraulic circuit from the master cylinder to the front brakes flows through part of the proportioning valve housing where the Bypass Valve

monitors front brake pressure. The spring pushes the bypass valve to the left and pushes the proportioning valve to the right, providing the proper spring tension for proportioning valve operation.

Rear brake hydraulic pressure pushes the bypass valve to the right while front brake pressure pushes the valve to the left. The overall hydraulic effect on the valve is neutral and the spring holds it to the left.

Bypass Valve Operation

Spring loaded to the left, the bypass valve establishes the spring position for normal proportioning operation.

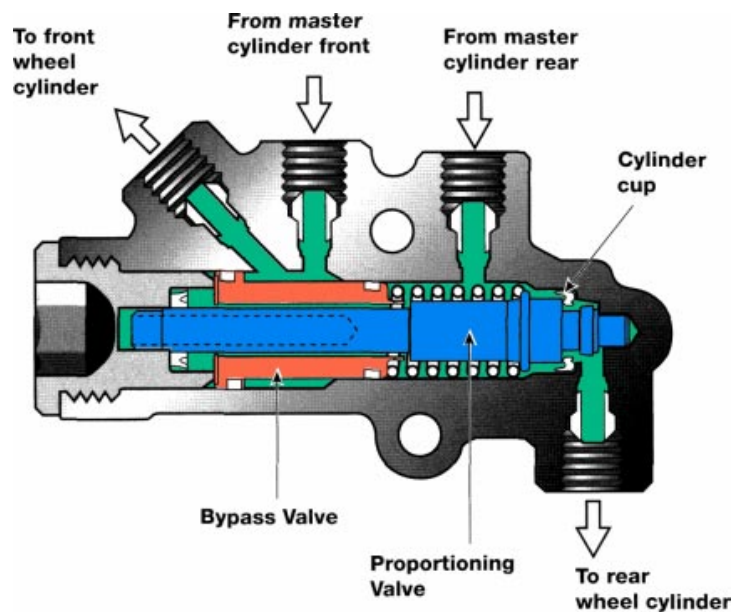

Should the hydraulic circuit to the front brakes fail, rear brake pressure will move the bypass valve to the right, forcing the proportioning valve to the right, which allows unregulated pressure to apply the rear brakes.

Bypass Valve Operation

The bypass valve moves right when front brake pressure drops, increasing spring tension of the proportioning valve thereby ensuring maximum pressure.

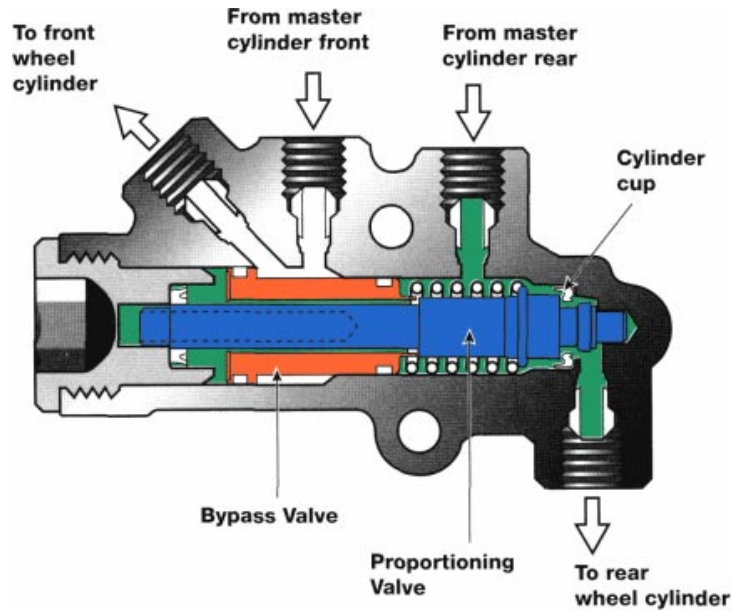

Double Proportioning Valve

The diagonal split brake system incorporated on all FWD vehicles uses a double proportioning valve in which two valves are arranged parallel to one another in the same valve housing. One valve controls pressure to the right rear brakes and the other valve controls pressure to the left rear brakes.

Proportioning Valve on Diagonal Split Brake System

All FWD vehicles use a double proportioning valve to control one front brake and one rear brake on the opposite side.

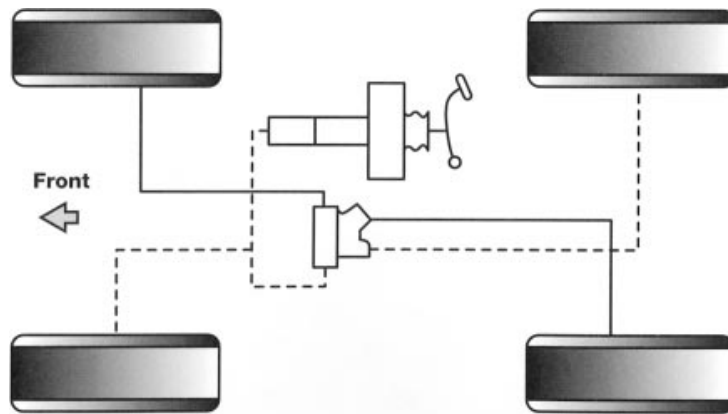

The movement of both valves is controlled by the tension of one spring. With a single spring, a balanced pressure is applied to each valve through the retainer.

Double Proportioning Valve

Both valves are controlled by the tension of one spring.

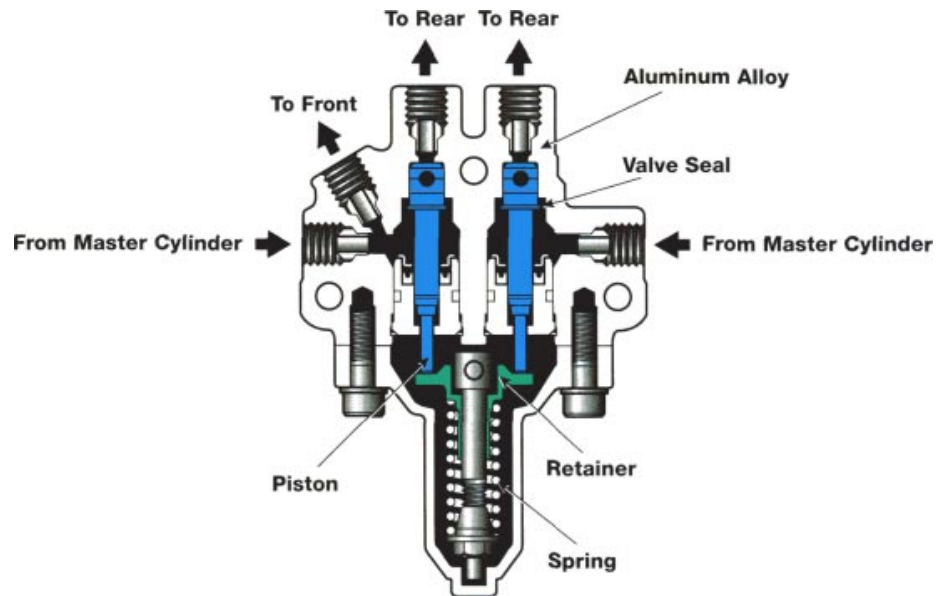

Pressure Loss in One Circuit

The real advantage to one spring is seen when one hydraulic circuit loses pressure. In this case only one valve counteracts the spring tension which requires additional hydraulic pressure to compress it. This results in higher pressure to the rear brake, providing a greater degree of vehicle control.

Rear Wheel Cylinder Pressure

When one circuit fails, pressure to the rear cylinder increases higher in proportion to master cylinder pressure because only one piston compresses the spring.

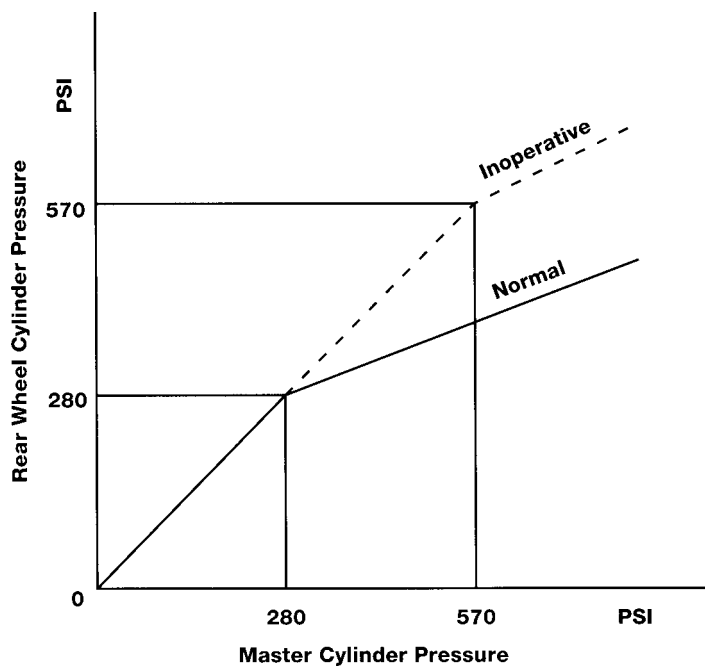

Load Sensing Proportioning Valve

The LSPV is used on Toyota models such as Truck, Van and Station Wagons which may be used to carry a variety of loads. The heavier the load, the greater the portion of braking is required of the rear brakes. The LSPV allows higher pressure to the rear brakes to accomplish this.

The LSPV is attached to the body or frame above the left rear control arm or axle housing. Load sensing is accomplished by suspending the sensing spring between the vehicle body and the rear axle housing. The load sensing spring movement caused by vehicle height changes due to load, is transmitted to the proportioning valve.

Load Sensing Proportioning Valve

Load sensing is accomplished by suspending the sensing spring between the vehicle body and the rear axle housing.

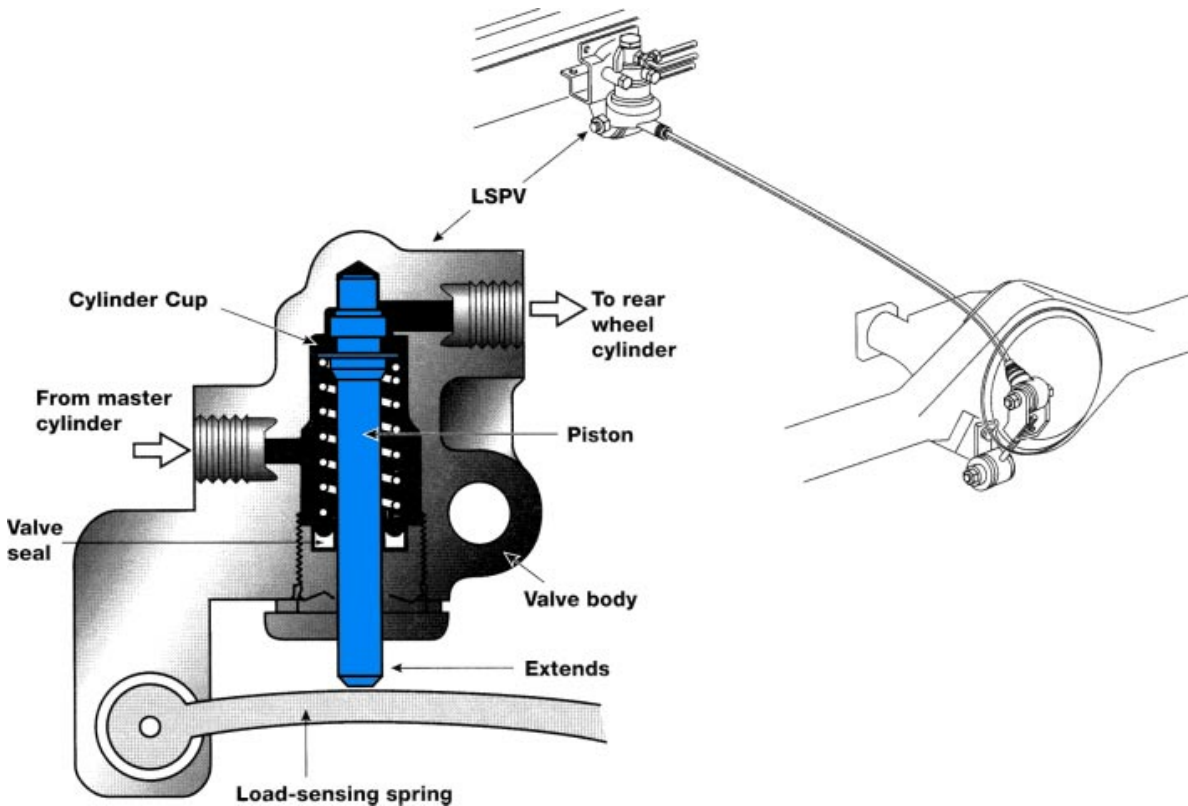

LSPV Operation As a vehicle is loaded, the leaf springs are compressed as the vehicle body lowers. The load sensing spring provides a variable force pushing the proportioning piston up as the vehicle is loaded. As the piston is lifted, a higher brake hydraulic pressure is required to force the piston down resulting in higher pressure at the rear wheels.

LSPV Lever Balance

The load sensing spring provides additional pressure to the proportioning valve based on vehicle load.

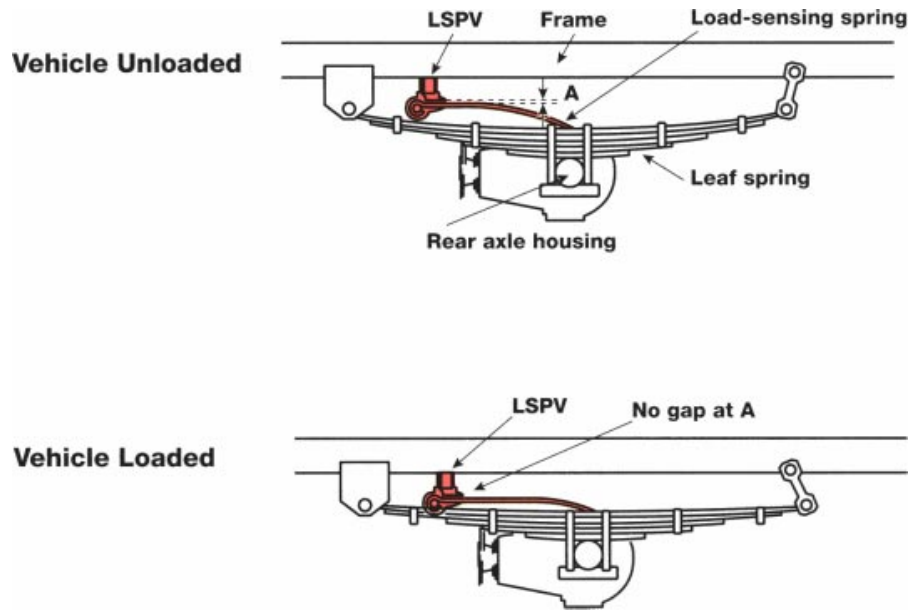

Rear wheel cylinder pressure is adjusted according to increases or decreases in vehicle load. The pressure change for one rear wheel is shown below.

LSPV Rear Wheel Cylinder Pressure

Pressure to the rear brakes is regulated at a higher pressure when the vehicle is loaded.

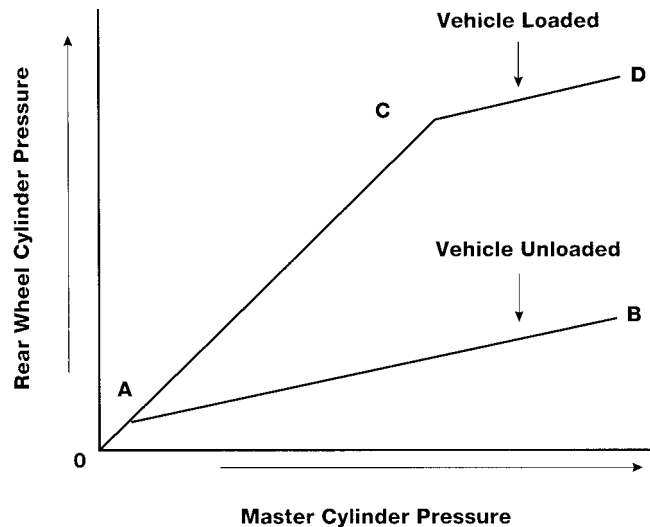

Unloaded Vehicle When unloaded, a vehicle body rises to normal vehicle height and no force from the load sensing spring is applied to the piston. The rear wheel cylinder is regulated at a lower pressure as shown by the line O - A - B in the chart on the previous page.

When the fluid pressure from the master cylinder is low the piston is pushed upward by the force of the piston spring. Fluid pressure is transmitted from chamber A through the passage into chamber B and to the rear wheel cylinder.

When the master cylinder pressure rises and pressure on the valve top (A2) becomes greater than piston spring tension, the piston is pushed downward and the valve is closed. Hydraulic pressure to the rear cylinders at this time will be as indicated by the point of deflection "A" in the graph. The upward force of the piston spring is equal to the downward force of hydraulic pressure when the valve is in the closed position.

As the master cylinder fluid pressure increases with further brake application, the piston is pushed upward again and the valve opens. Pressure to the rear wheel cylinders increases when the valve opens, but the piston is pushed down before wheel cylinder pressure becomes equal to master cylinder pressure, and the valve closes.

Proportioning Valve in Unloaded Position

The proportioning valve is normally open. When the master cylinder pressure rises and pressure on the valve top (A2) becomes greater than piston spring tension, the piston is pushed downward and the valve is closed.

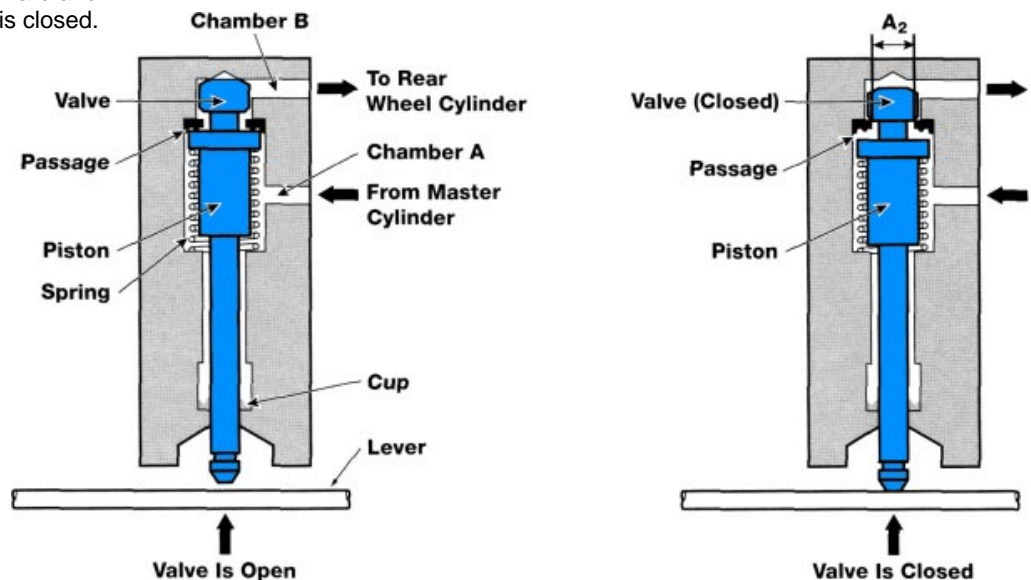

Loaded Vehicle As the load in the vehicle is increased, the vehicle body moves down, and the LSPV piston is pushed up by the lever causing the rear wheel cylinder to be regulated at a higher pressure as shown in the graph (O - C - D).

When the fluid pressure from the master cylinder is low, the hydraulic pressure going to the rear wheel cylinder is not controlled. As master cylinder pressure rises and becomes greater than the combined spring tension, the piston is pushed downward and the valve is closed regulating pressure to the rear brake cylinder.

Proportioning Valve in the Loaded Position

The LSPV piston is pushed up by the lever causing the rear wheel cylinder pressure to increase.

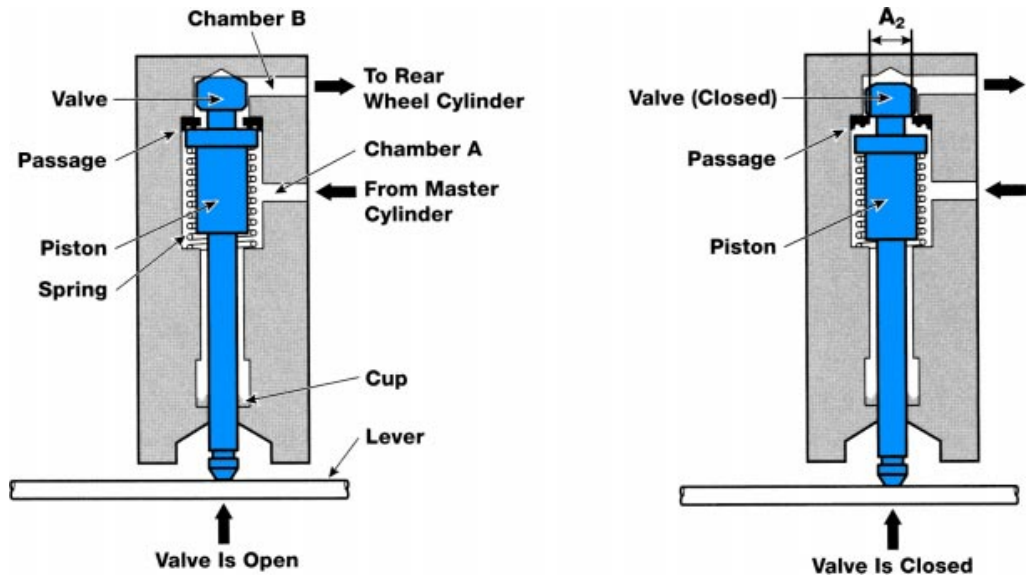

Load Sensing Proportioning and Bypass Valve

The LSPBV is used on Previa's, Trucks, Tacoma's, T-100's, Cab and Chassis 2WD and 4WD models. The LSPBV is a LSPV to which a bypass circuit has been added. The operation of the bypass valve is similar to the Proportioning and Bypass Valve.

When the front brake circuit is operating normally, the LSPBV varies the pressure transmitted from the master cylinder to the rear wheels based on vehicle load, in the same way as the LSPV. However, if the front brake circuit fails, hydraulic pressure is transmitted directly to the rear wheel cylinders, bypassing the proportioning part of the valve so that enough braking force can be applied.

The hydraulic sensing circuit which links the front brake hydraulic circuit to the LSPBV, is part of the front hydraulic circuit. When bleeding the front brake system, be sure to bleed air from the LSPBV as well, or the pedal may feel spongy with diminished brake performance.

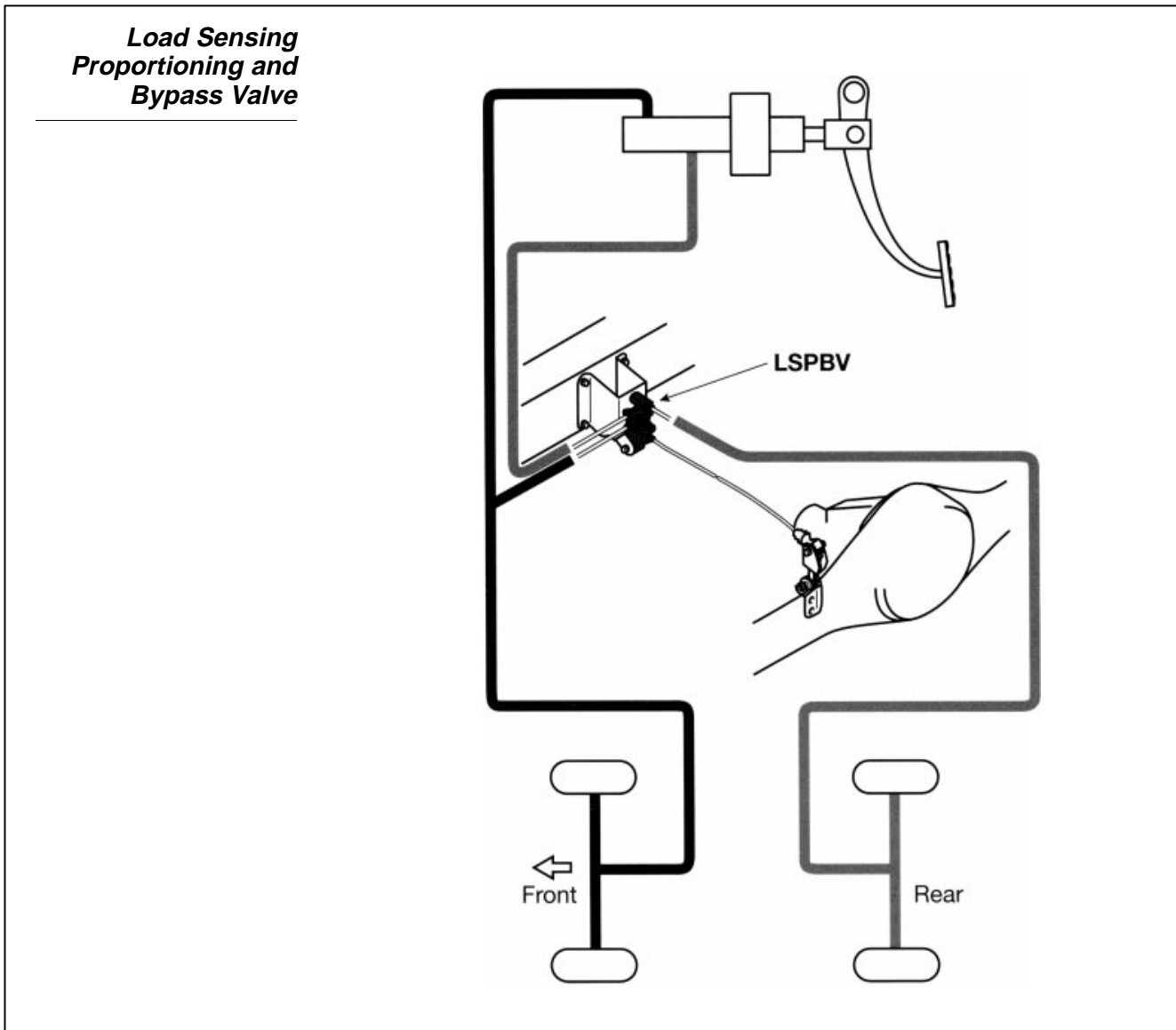

Bypass Valve Operation When the front brake circuit is operating normally, pressure from the master cylinder front and master cylinder rear are equal. The bypass piston is pushed and held down by the spring.

If pressure from the front brakes falls to zero, a difference will exist between the hydraulic pressure pushing the bypass valve up and the pressure pushing the valve down. This causes the bypass valve to be pushed upward, pushing the piston upward, and opening the passage at the top of the valve. The hydraulic pressure from the master cylinder is not controlled. Full pressure from the master cylinder is transmitted to the rear wheel cylinder.

Fail-safe Operation

When pressure from the front brakes (P_f) is lost, Piston No. 2 rises compressing the spring and opening the valve.

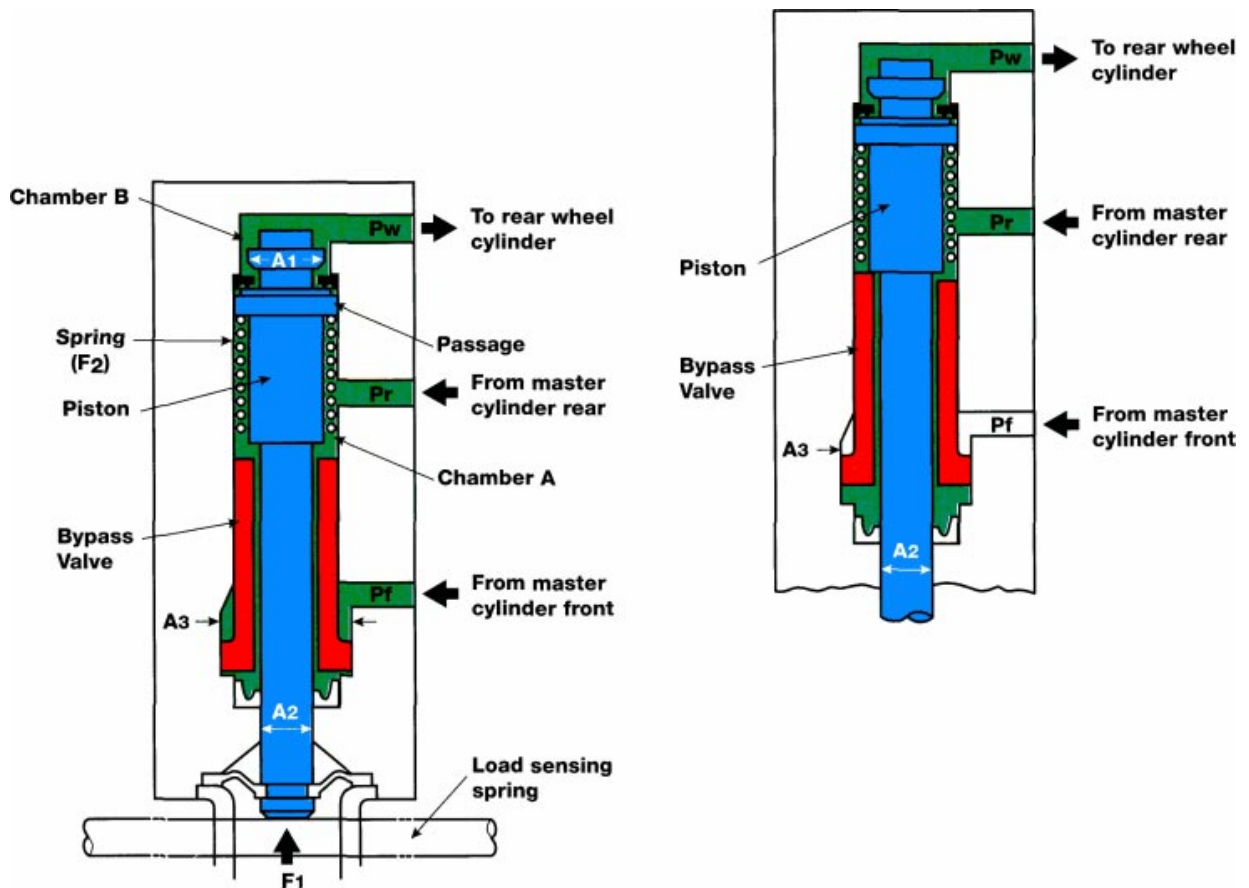

LSPV Adjustment Adjustment of the LSPV is accomplished by changing the length of (A) in the illustrations below. The distance has an initial length which can be found in the Repair Manual.

Adjustment Length



If distance (A) is too short, the hydraulic pressure breaking point will decrease. Hydraulic pressure to the rear wheel cylinders will be lower than normal, reducing braking performance.

When distance (A) is too long, the hydraulic pressure breaking point will rise. Hydraulic pressure to the rear wheel cylinder will be higher than normal, increasing the braking force of the rear wheels.

To adjust the valve properly and ensure efficient braking, the LSPV gauge (SST 09709-29017-01) must be used to measure the front and rear brake pressure.

Pressure Gauge SST

To adjust the valve properly and ensure efficient braking, the LSPV gauge (SST 09709-29017-01) must be used to measure the front and rear brake pressure.



The gauges are provided in the SST Kit. Install one gauge at the front wheel cylinder. The other gauge is installed at the rear wheel cylinder. Having opened the system, the air must be bled from the system before accurate system pressures can be read. Bleed screws are located on the hose end of the gauge.

Follow the procedure outlined in the Repair Manual to determine the following:

1. Rear axle load (based on vehicle model).
2. Front brake pressure specifications.
3. Rear brake pressure specifications.

The weight of the vehicle measured at the rear axle must be determined and additional weight added to meet the Repair Manual specification. This will establish the proper relationship of the proportioning valve and the rear axle housing.

Hydraulic Pressure Measurement

Hydraulic pressure at the front brake should be compared with the pressure of the rear brake in two stages.

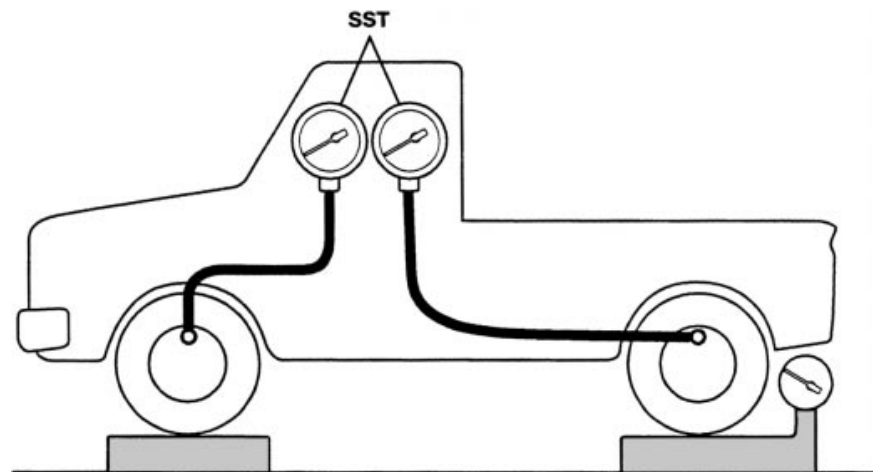

Next, the hydraulic pressure at the front brake should be compared with the pressure of the rear brake in two or three stages as specified in the Repair Manual.

- First, the front pressure is brought to a specified pressure (example: 1,138 psi) and the rear pressure should be within a specific pressure range (example: 583 psi to 768 psi).
- Second, without releasing the brake pedal, the front pressure is increased (example: 1,422 psi) and the rear brake pressure should increase (example: between 688 psi to 873 psi).

NOTE

Rear pressure readings should be taken within two seconds of obtaining the specified front pressure.

If the rear pressures do not fall within the stated specification, adjust distance (A):

- Lengthening (A) if the pressure is low.
- Shortening (A) if the pressure is high.

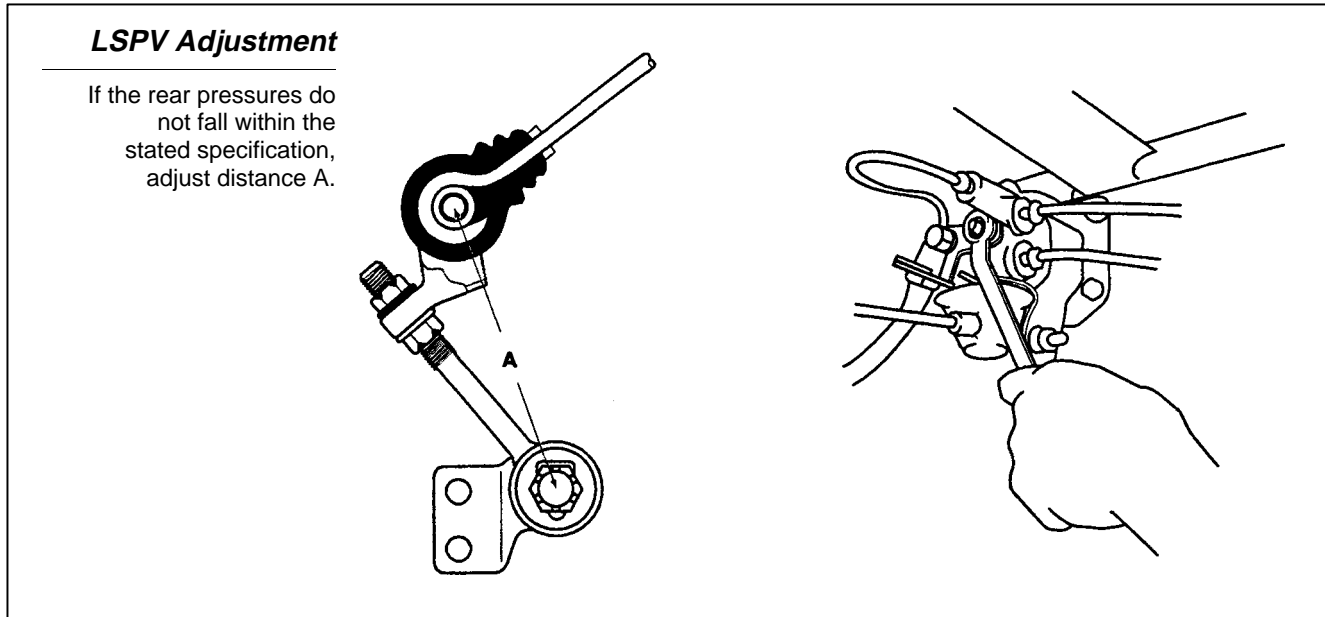

If adjustment of the springs does not bring the rear pressure into specification, adjust the valve body:

- If pressure is low, lower the valve body.
- If the pressure is high, raise the valve body.



WORKSHEET 8-1 (ON-CAR)
LSPV Adjustment

Vehicle	Year/Prod. Date	Engine	Transmission
---------	-----------------	--------	--------------

Worksheet Objectives

In this Worksheet you will practice the procedure for measuring and adjusting the LSPV.

Tools and Equipment:

- LSPV Pressure Gauge SST. (09709-29017-01)
- Weight Scale Printout.
- Hand Tool Set.
- Tape Measure or Ruler.
- Brake Fluid.
- Repair Manual.

Preparation:

- Raise the vehicle on a lift and install the LSPV gauges.
- Bleed air from the brake lines.
- Place weight scales under the wheels and lower the vehicle onto the scales.

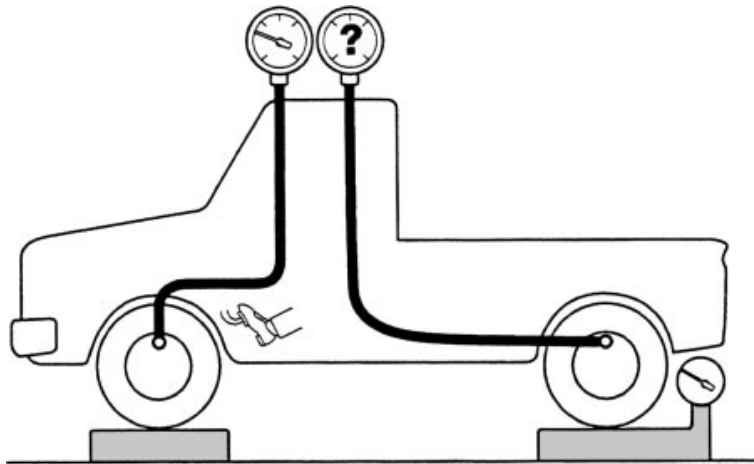

Measurement:

1. Record the specified weight from Repair Manual, subtract the rear vehicle weight to find amount of additional weight required. Additional weight should be placed above the rear axle.

Specified Weight	
Rear Axle Weight	
Added Weight	

Measurement (cont'd):

- Raise front brake pressure and check rear brake pressure.

Model	Front Pressure Spec.	Rear Axle Spec.	Rear Axle Measured

- How does this compare to the specified pressure? _____

LSPV Adjustment:

- Record the initial length of the No.2 shackle. _____
- Rotate the adjusting nut two (2) complete turns and record the change in rear pressure. _____
- Recheck the pressures, has the pressure at the rear brakes increased or decreased? _____
If so, by how much? _____

Summary:

- Why is the weighting of the rear of the vehicle important?

- What effect would mis-adjustment have on the brake system?

- Refer to the Repair Manual for Previa and Camry and record the pressure change for each rotation of the No.2 shackle adjusting nut.

- To increase the pressure at the rear wheels, would the No.2 shackle be shortened or lengthened?

