

# COMPONENT PARTS INSTALLATION

## COMPONENT PARTS INSTALLATION

(See page [MX1-19](#) and [MX1-20](#))

HINT: Coat all of the sliding and rotating surface with gear oil before assembly.

1. INSPECT DIFFERENTIAL SIDE BEARING PRELOAD  
(See step 4 on page [MX1-54](#))

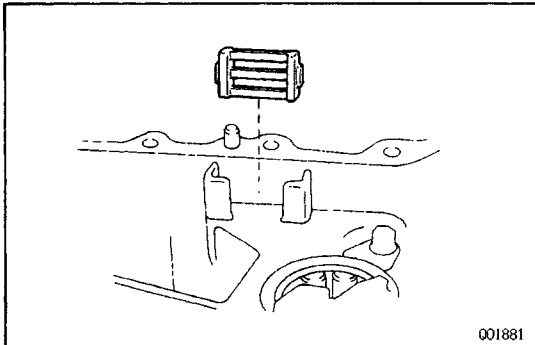

2. INSTALL MAGNET TO TRANSAXLE CASE

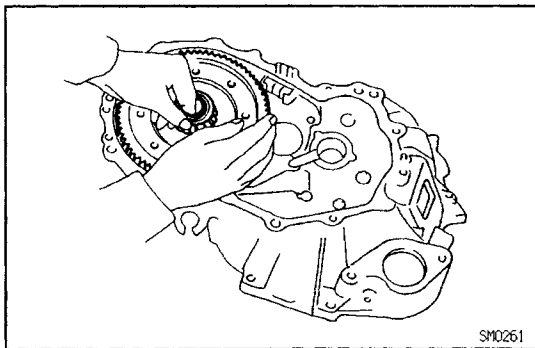

3. INSTALL DIFFERENTIAL CASE ASSEMBLY

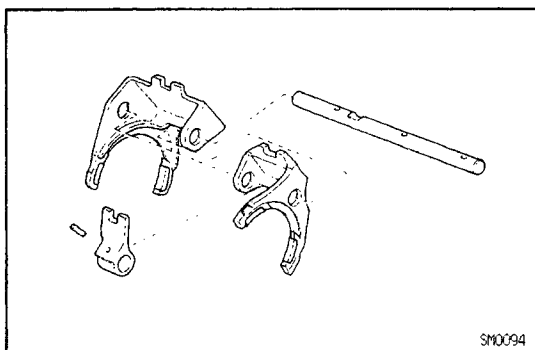

4. ASSEMBLE NO.1 SHIFT FRONT SHAFT, NO.1 SHIFT HEAD, NO.1 AND NO.2 SHIFT FORKS

(a) Assemble the No.1 shift fork shaft, No.1 shift head, No.1 and No.2 shift forks.

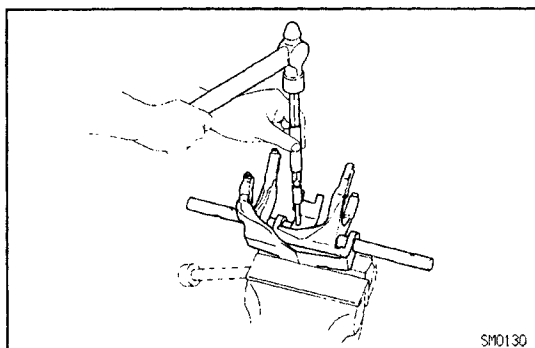

(b) Mount the shift forks to the vise.

(c) Using a pin punch and hammer, drive in the slotted spring pin to the No.1 fork shaft as shown in the figure.

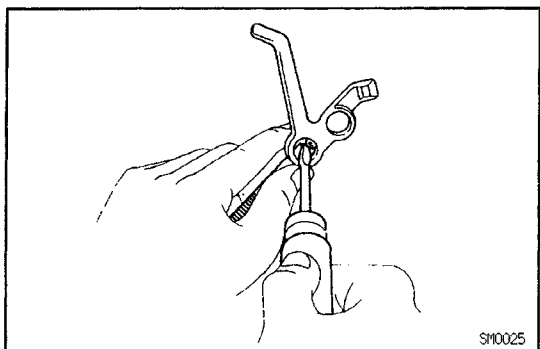

- (d) Coat the interlock pin with MP grease.
- (e) Using a screwdriver, install the interlock pin into the reverse shift fork hole.
- (f) Install the reverse shift fork to the No.1 shift fork shaft.

HINT: When installing the reverse shift fork with interlock pin to the No.1 shift fork shaft, make sure the interlock pin does not drop out.

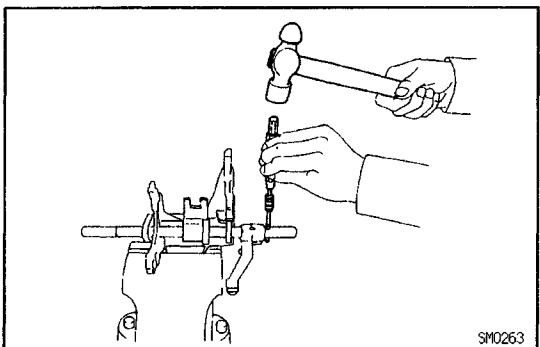

- (g) Using a pin punch and hammer, drive in the slotted spring pin to the No.1 fork shaft.

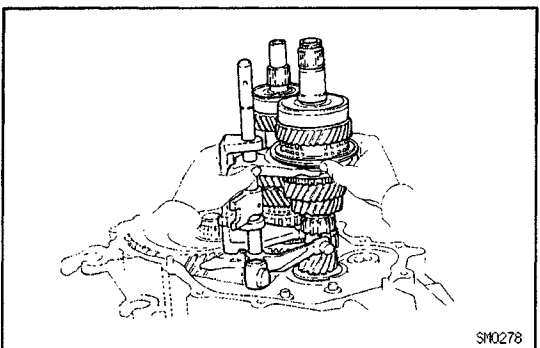

#### 5. INSTALL NO.1 SHIFT FORK SHAFT, NO.1 SHIFT HEAD, NO.1, NO.2 SHIFT FORKS, REVERSE SHIFT FORK WITH INTERLOCK PIN, INPUT AND OUTPUT SHAFT ASSEMBLY

Install the input and output shaft assembly together with the No.1 fork shaft, shift head and shift forks with the interlock pin to the transaxle case.

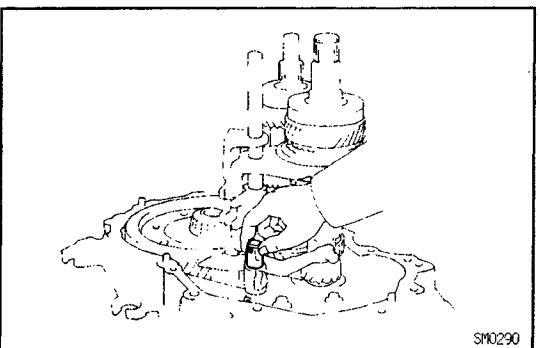

#### 6. INSTALL NO.2 FORK SHAFT

- (a) Install the No.2 fork shaft to the transaxle case through the reverse shift fork.

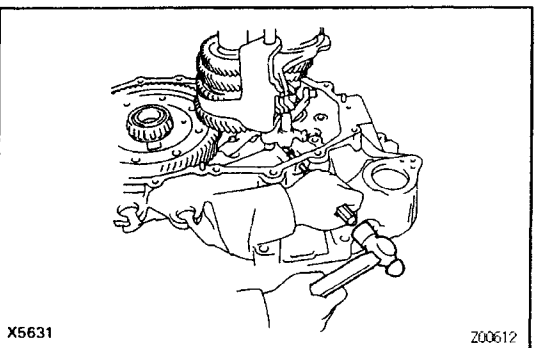

- (b) Using a pin punch and hammer, drive in the slotted spring pin.

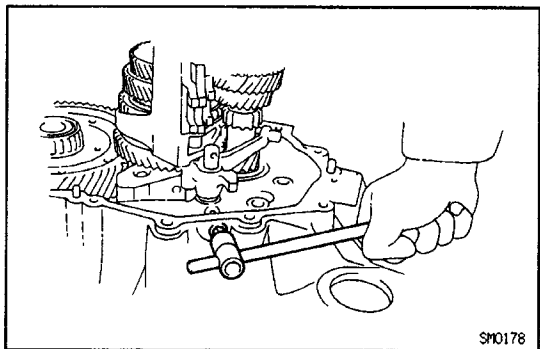

(c) Apply sealant to the plug threads.

**Sealant:**

**Part No.08833-00080, THREE BOND 7344,  
LOCTITE 242 or equivalent**

(d) Using a hexagon wrench (6 mm), install the straight screw plug.

**Torque: 13 N-m (130 kgf-cm, 9 ft-lbf)**

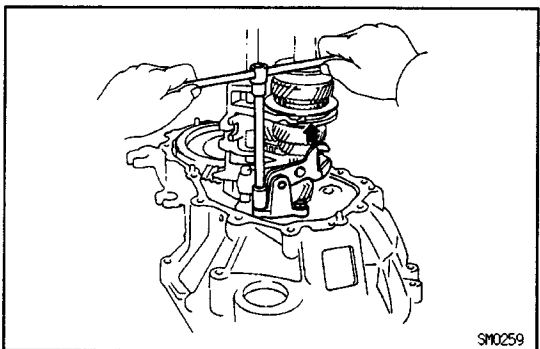

**7. INSTALL REVERSE SHIFT ARM**

(a) Put the reverse shift fork pivot into the reverse shift arm and install the reverse shift arm to the transaxle case.

(b) Shift the reverse shift arm into the reverse.

(c) Install and torque the two bolts.

**Torque: 18 N-m (185 kgf-cm, 13 ft-lbf)**

(d) Shift the reverse shift arm to the neutral position.

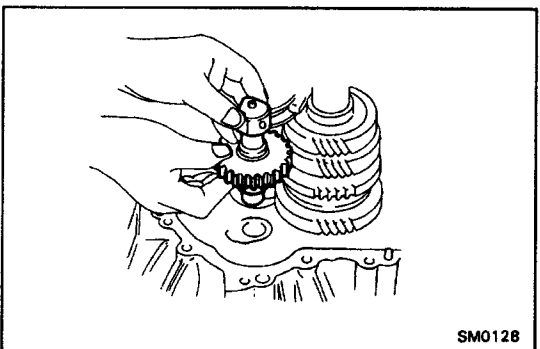

**8. INSTALL REVERSE IDLER GEAR AND SHAFT**

(a) Install the washer and reverse idler gear to the shaft.

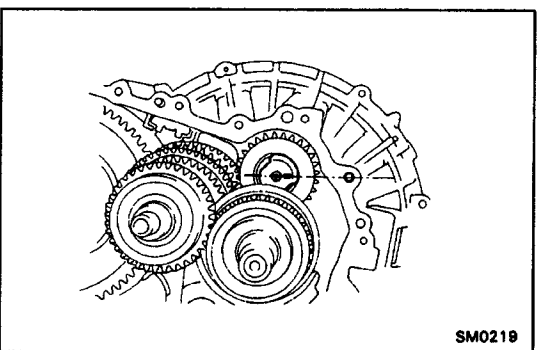

(b) Install the reverse idler gear and shaft as shown.

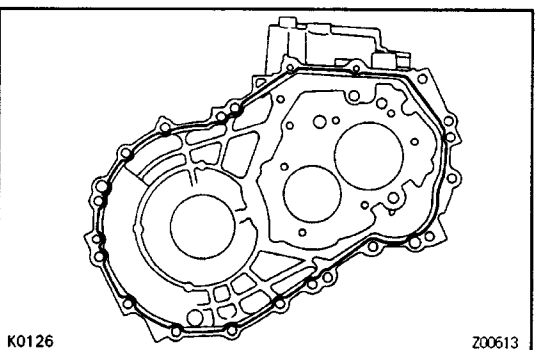

**9. INSTALL TRANSMISSION CASE**

(a) Remove the any packing material and be careful not to drop oil on the contacting surface of the transaxle case or transmission case.

(b) Apply seal packing to the transmission case as shown.

**Seal packing:**

**Part No. 08833 – 00090, THREE BOND 1281 or  
equivalent**

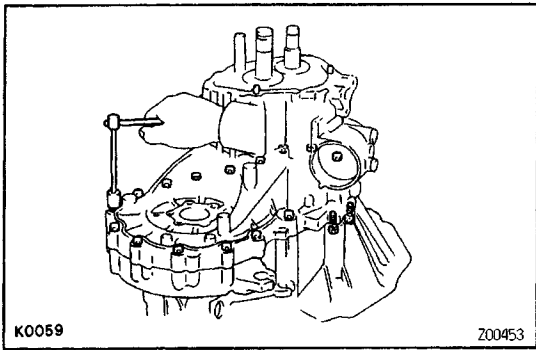

(c) Install and torque the seventeen bolts.

**Torque: 29 N-m (300 kgf-cm, 22 ft-lbf)**

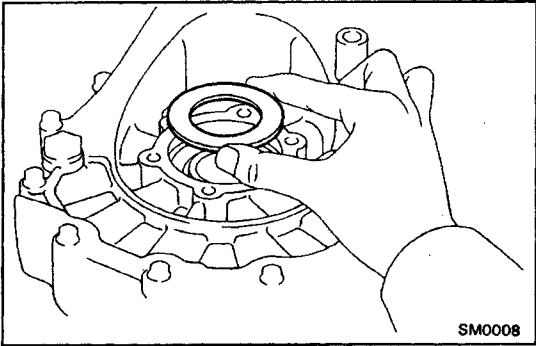

#### 10. INSTALL SHIM AND SIDE SEARING RETAINER WITH O-RING

- (a) Install a new O-ring on the retainer.  
 (b) Install the shim and retainer.

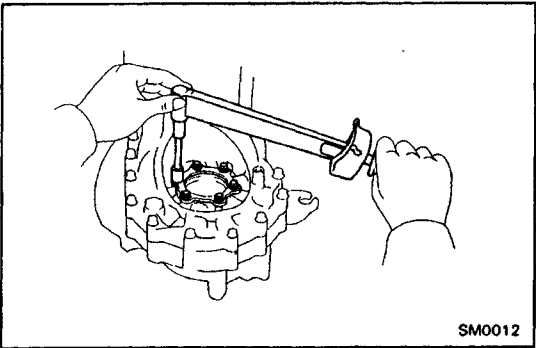

(c) Apply sealant to the bolt threads.

**Sealant:**

**Part No.08833-00080, THREE BOND 1344,  
 LOCTITE 242 or equivalent**

(d) Install and torque the six bolts.

**Torque: 18 N-m (185 kgf-cm, 13 ft-lbf)**

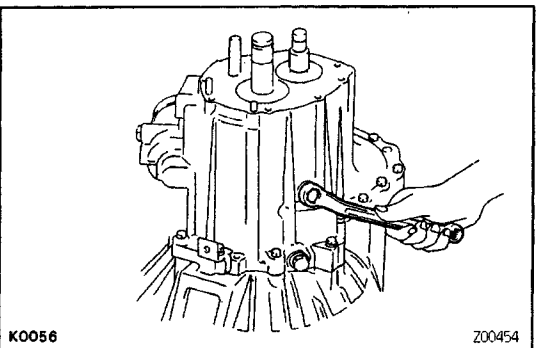

#### 11. INSTALL AND TORQUE REVERSE IDLER GEAR SHAFT LOCK BOLT

**Torque: 29 N-m (300 kgf-cm, 22 ft-lbf)**

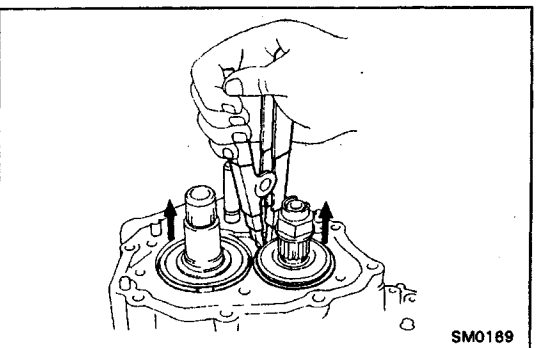

#### 12. INSTALL BEARING SNAP RINGS

Using a snap ring expander, install the two snap rings.

**HINT:** If it is difficult to install the snap ring, pull up the shafts.

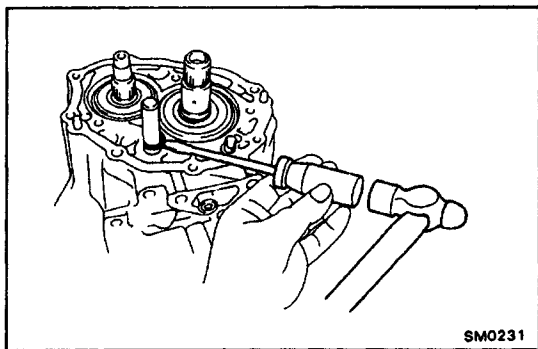
**13. INSTALL NO.1 FORK SHAFT SNAP RING**

Using a screwdriver and hammer, tap in the snap ring.

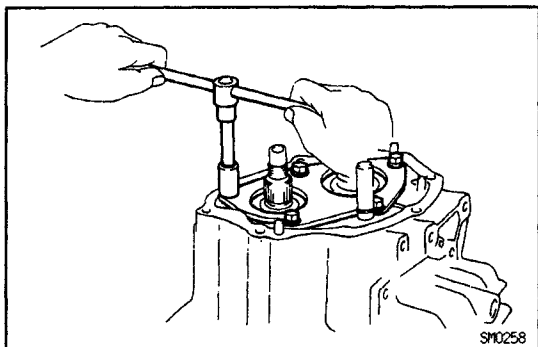
**14. INSTALL REAR BEARING RETAINER**

(a) Apply sealant to the bolt threads.

**Sealant:**

**Part No. 08833 – 00070, THREE BOND 1324 or equivalent**

(b) Install and torque the five bolts.

**Torque: 42 N-m (430 kgf-cm, 31 ft-lbf)**

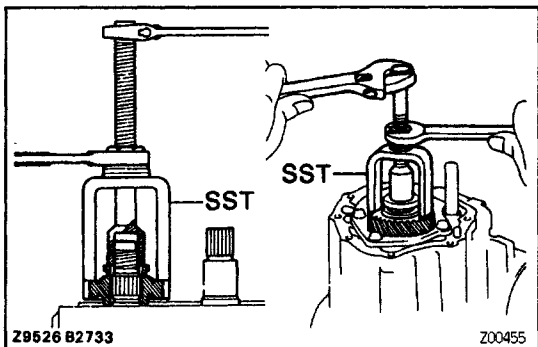
**15. INSTALL FIFTH DRIVEN GEAR**

Using SST, install the 5th driven gear.  
SST 09309-12020

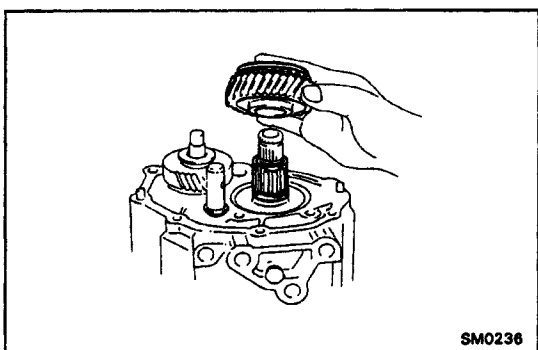
**16. INSTALL SPACER, NEEDLE ROLLER BEARINGS, FIFTH GEAR AND SYNCHRONIZER RING**

(a) Install the spacer.

(b) Apply gear oil to the needle roller bearings.

(c) Install the 5th gear with the needle roller bearings and synchronizer ring.

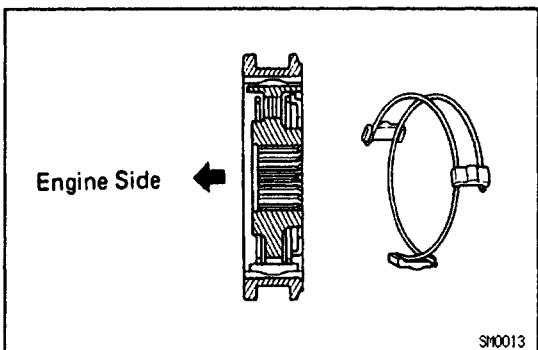
**17. INSTALL NO.3 CLUTCH HUB INTO HUB SLEEVE**

(a) Install the clutch hub and three shifting keys to the hub sleeve.

(b) Install the two shifting key springs under the shifting keys.

**NOTICE:** Install the key springs positioned so that their end gaps are not in line.

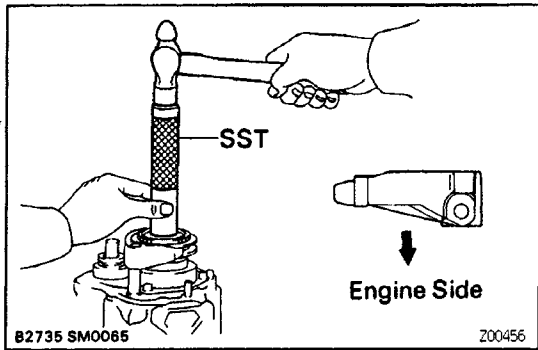

**18. INSTALL NO. 3 HUB SLEEVE ASSEMBLY WITH SHIFT FORK**

- (a) Support the tip of the input shaft with a spacer or such to raise the transaxle assembly.
- (b) Using SST and a hammer, drive in the No.3 hub sleeve with shift fork.  
SST 09612-22011

**NOTICE:** Align the synchronizer ring slots with the shifting keys.

- (c) Install and torque the bolt to the No.3 shift fork.  
**Torque: 18 N-m (185 kgf-cm, 13 ft-lbf)**

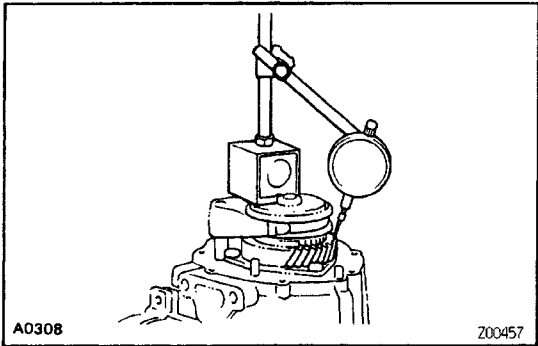

**19. INSPECT FIFTH GEAR THRUST CLEARANCE**

- Using a dial indicator, measure the thrust clearance.  
**Standard clearance:**  
**0.20-0.40 mm (0.0089-0.0157 in.)**

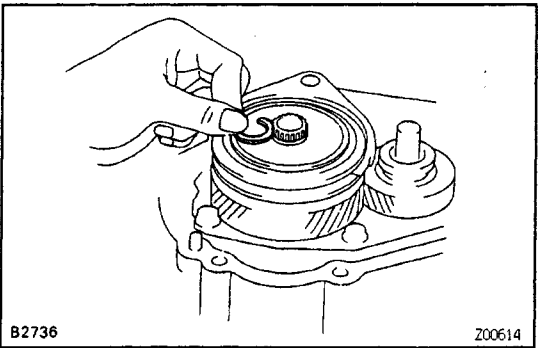

**20. INSTALL SHIFTING KEY RETAINER AND SNAP RING**

- (a) Install the retainer.
- (b) Select a snap ring that will allow minimum axial play.

Mark	Thickness mm (in.)	Mark	Thickness mm (in.)
13	2.20-2.25 (0.0866-0.0885)	21	2.60-2.65 (0.1024-0.1043)
14	2.25-2.30 (0.0885-0.0906)	22	2.65-2.70 (0.1043-0.1063)
15	2.30-2.35 (0.0906-0.0925)	23	2.70-2.75 (0.1063-0.1083)
16	2.35-2.40 (0.0925-0.0945)	24	2.75-2.80 (0.1083-0.1102)
17	2.40-2.45 (0.0945-0.0965)	25	2.80-2.85 (0.1102-0.1122)
18	2.45-2.50 (0.0965-0.0984)	26	2.85-2.90 (0.1122-0.1142)
19	2.50-2.55 (0.0984-0.1004)	27	2.90-2.95 (0.1142-0.1161)
20	2.55-2.60 (0.1004-0.1024)		

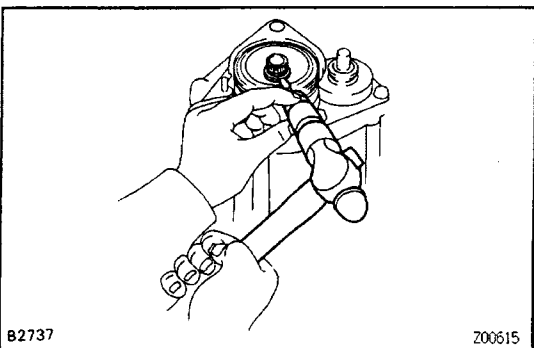

- (c) Using a screwdriver and hammer, tap in the snap ring.

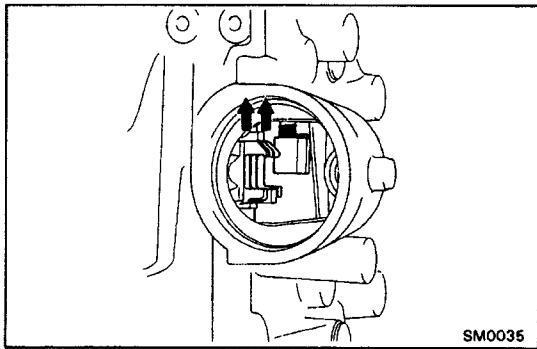

## 21. INSTALL OUTPUT SHAFT LOCK NUT

(a) Engage the gear double meshing.

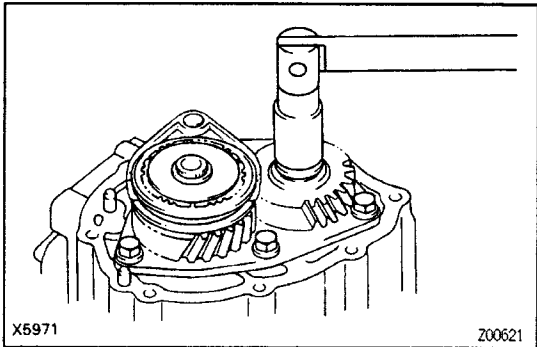

(b) Install and torque the new lock nut.  
**Torque: 123 N-m (1,250 kgf-cm, 90 ft-lbf)**

**HINT:** The lock nut has LH threads.

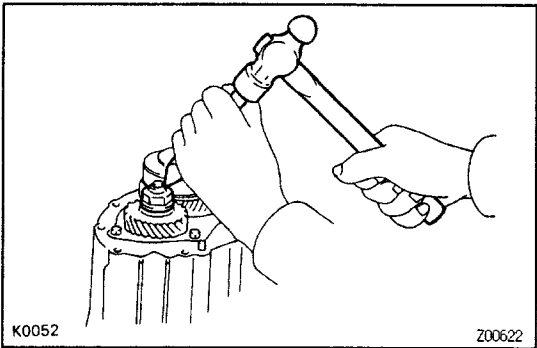

(c) Stake the lock nut.

(d) Disengage the gear double meshing.

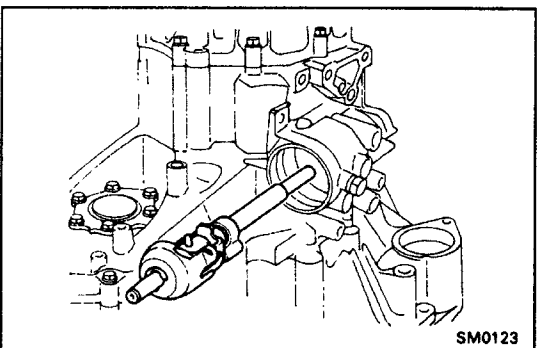

## 22. INSTALL SHIFT AND SELECT LEVER SHAFT ASSEMBLY

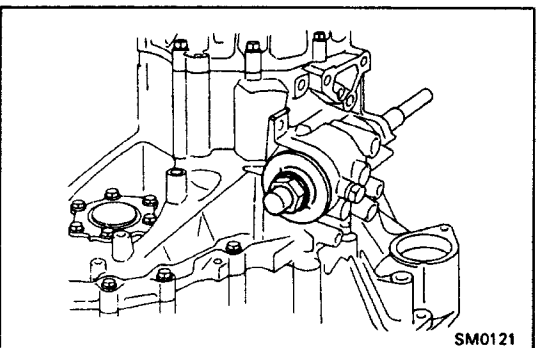

## 23. INSTALL CONTROL SHAFT COVER

(a) Install a new O-ring and control shaft cover.

(b) Install and torque the control shaft cover.

**Torque: 33 N-m (335 kgf-cm, 24 ft-lbf)**

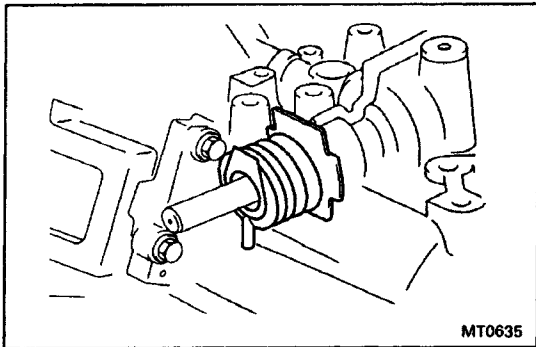

## 24. INSTALL SHIFT LEVER

- (a) Install the boot to the control shaft oil seal.

HINT: Make sure to install the boot in the correct direction. Position the air bleed of the boot downward.

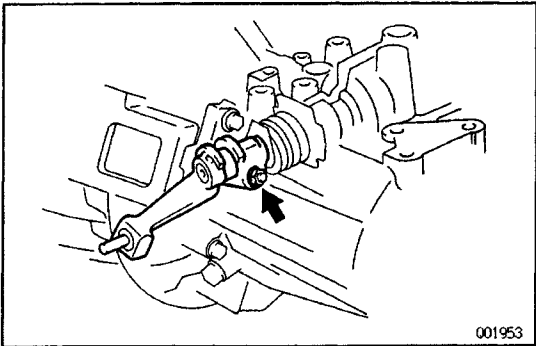

- (b) Fit the pin's groove into the shaft's notch and tap on with a hammer.

- (c) Install and torque the nut.

**Torque: 12 N-m (120 kgf-cm, 9 ft-lbf)**

- (d) Install the boot to the shift lever.

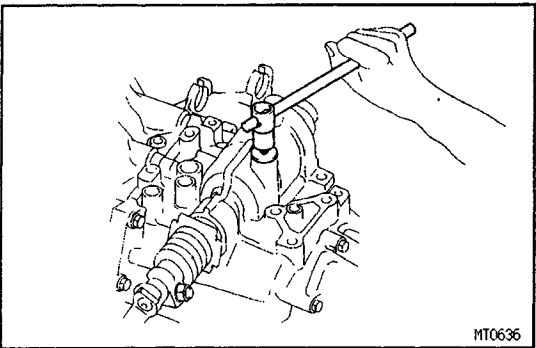

## 25. INSTALL NO.2 LOCK BALL ASSEMBLY

- (a) Apply sealant to the lock ball assembly threads.

**Sealant:**

**Part No.08833-00080, THREE BOND 1344, LOCTITE 242 or equivalent**

- (b) Using a hexagon wrench (6 mm), install and torque the plug.

**Torque: 23 N-m (230 kgf-cm, 17 ft-lbf)**

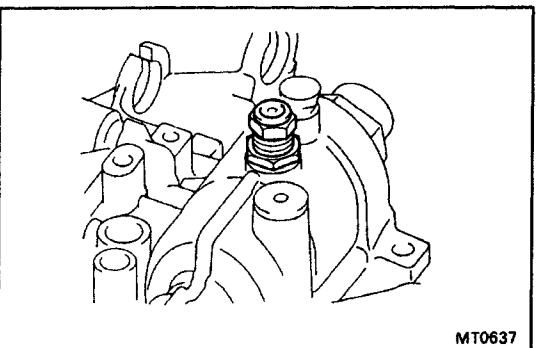

## 26. INSTALL AND ADJUST NO.1 LOCK BALL ASSEMBLY

- (a) Fully loosen the lock nut.  
 (b) Fully screw in the lock ball.  
 (c) Loosen the lock ball to where the play at the shift outer lever tip is 0.1 –0.5 mm (0.004–0.020in.).  
 (d) Hold the lock ball and tighten the lock nut.

**Torque: 37 N-m (375 kgf-cm, 27 ft-lbf)**

- (e) Check the shift outer lever tip play.

**Lever tip play:**

**0.1–0.5 mm (0.004–0.020 in.)**

## 27. INSTALL TRANSMISSION CASE COVER

- (a) Remove the any packing material an be careful not to drop oil on the contacting surface of the transmission case or transmission case cover.  
 (b) Apply seal packing to the transmission case cover as shown.

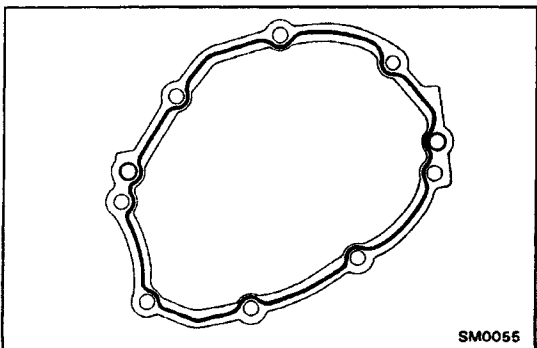

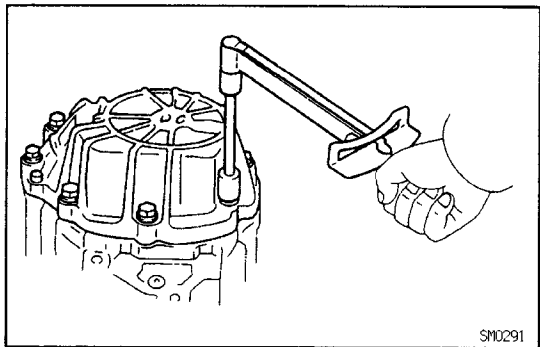

**Seal packing:**

Part No. 08826 – 00090, THREE BOND 1281 or equivalent

- (c) Install the transmission case cover.  
 (d) Apply sealant to the bolt threads.

**Sealant:**

Part No.08833–00080, THREE BOND 1344, LOCTITE 242 or equivalent

- (e) Install and torque the eight bolts.

Torque: 29 N–m (300 kgf–cm, 22 ft–lbf)

## 28. INSTALL ENGINE MOUNT BRACKET AND SELECTING BELLCRANK

- (a) Install the engine mount bracket and torque the three bolts.

Torque: 52 N–m (530 kgf–cm, 38 ft–lbf)

- (b) Install the selecting bellcrank with bolt.

Torque: 20 N–m (200 kgf–cm, 14 ft–lbf)

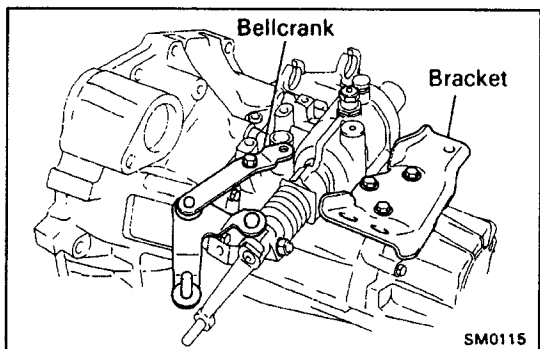

## 29. INSTALL RELEASE BEARING RETAINER

Install the release bearing retainer and torque the three bolts.

Torque: 7.4 N–m (75 kgf–cm, 65 ft–lbf)

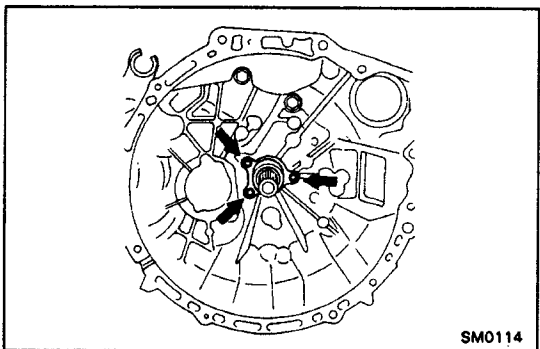

## 30. INSTALL BACK-UP LIGHT SWITCH

Torque: 44 N–m (450 kgf–cm, 33 ft–lbf)

## 31. INSTALL VEHICLE SPEED PULSE GENERATOR

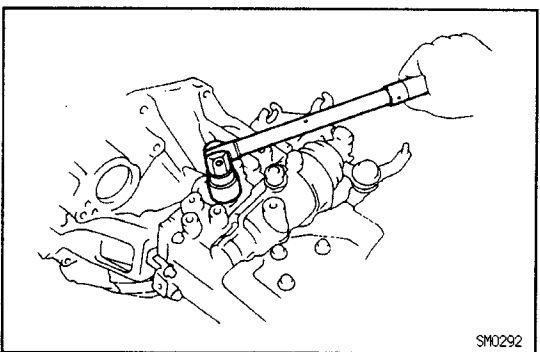

## 32. INSTALL RELEASE FORK AND BEARING

- (a) Apply molybdenum disulphide lithium base grease to the following parts:

- Release bearing hub inside groove
- Input shaft spline
- Release fork contact surface

- (b) Apply MP grease to the front surface of the release bearing.

