

TOYOTA

Owner's Manual

*For your safety and comfort,
read carefully and keep in the vehicle.*

MR2

Foreword

Welcome to the growing group of value-conscious people who drive Toyotas. We are proud of the advanced engineering and quality construction of each vehicle we build.

Please read this Owner's Manual and follow its instructions carefully. It is designed to acquaint you with the features of your new Toyota and to help you enjoy many kilometers/miles of motoring pleasure in safety.

When it comes to service, remember that your Toyota dealer knows your vehicle best and is interested in your complete satisfaction. He will provide quality maintenance and any other assistance you may require.

Please leave this Owner's Manual in this vehicle at the time of resale. The next owner will need this information also.

All information and specifications in this manual are current at the time of printing. However, because of Toyota's policy of continual product improvement, we reserve the right to make changes at any time without notice.

Please note that this manual applies to all models and explains all equipment, including options. Therefore, you may find some explanations for equipment not installed on your vehicle.

TOYOTA MOTOR CORPORATION

©1988 TOYOTA MOTOR CORPORATION

All rights reserved. This material may not be reproduced or copied, in whole or in part, without the written permission of Toyota Motor Corporation.

Information for the new owner—Section 1

Catalytic converter

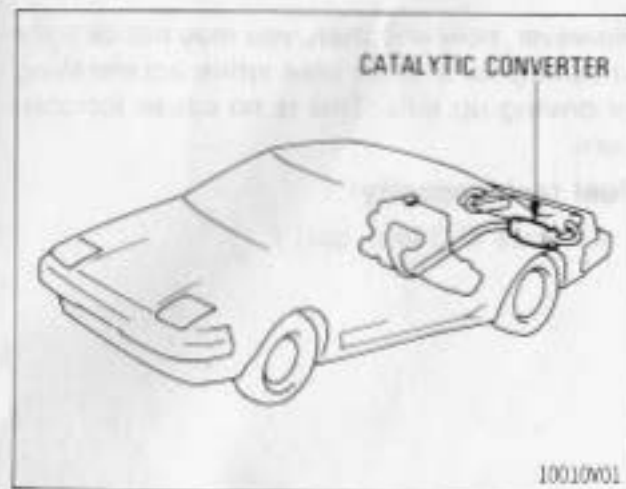

The catalytic converter is an emission control device installed in the exhaust system.

It looks somewhat like a muffler, but its purpose is to reduce pollutants in the exhaust gas.

WARNING:

A large amount of unburned gas flowing into the converter may cause it to overheat and create a fire hazard. To prevent this and other damage, observe the following precautions:

- Do not drive with an extremely low fuel level; running out of gas could cause the engine to misfire, creating an excessive load on the converter.

- Do not allow the engine to run at idle speed for more than 20 minutes.
- Keep your engine in good running order. Malfunctions in the engine electrical, ignition or fuel systems could cause an extremely high converter temperature.
- Do not push-start or pull-start your vehicle.
- Do not turn off the ignition while the vehicle is moving.
- Do not drive, idle or park your vehicle over anything that might burn easily such as grass, leaves, paper or rags.
- Keep people and combustible materials away from the exhaust pipe while the engine is running. The exhaust gas is very hot.
- Avoid racing the engine.
- Use only unleaded gasoline.
- If the engine becomes difficult to start or stalls frequently, take your vehicle in for a check-up as soon as possible. Remember, your Toyota dealer knows your vehicle and its catalytic converter system best.

To insure that the converter and the entire emission control system operate properly, your vehicle must receive the periodic inspections required by the Toyota Maintenance Schedule.



Vehicles with catalytic converters use only unleaded gasoline with the following octane number or higher (check for octane number).

Model Year 1988-1990 87

Model Year 1991-1992 89

Model Year 1993-1994 90

Fuel recommendation

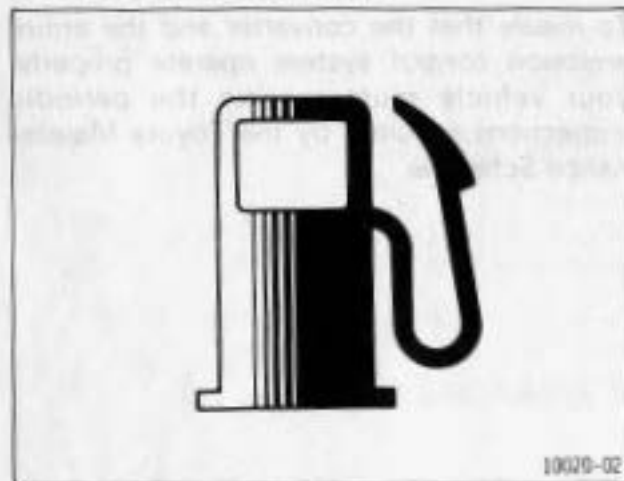

Vehicles with catalytic converter: Use only unleaded gasoline with the following octane number or higher (Research Octane Number).

Europe	95
Others	91

Vehicles sold in Europe—If you can not obtain the gasoline with the octane number designated above by any means, you may temporarily use gasolines with the octane number as low as 91 with the fuel control connector properly adjusted.

See "Adjusting the fuel control connector" in Section 6.

Use of leaded gasoline will cause the catalytic converter to lose its effectiveness and the emission control system to function improperly. Also, this can increase maintenance costs.

To help prevent gas station mixups, your Toyota has a new smaller fuel tank opening. The special nozzle on pumps with unleaded fuel will fit it, but the larger standard nozzle on pumps with leaded gas will not.

Vehicles without catalytic converter: Use gasoline, leaded or unleaded, with the following octane number or higher (Research Octane Number).

Europe	95
Others	94

Engine damage caused by use of improper fuels is not covered under Toyota's new vehicle warranty.

Use of fuel with an octane number lower than stated will cause persistent heavy knocking. If severe, this will lead to engine damage.

If you detect heavy knocking even when using the recommended fuel, or if you hear steady knocking while holding a steady speed on level roads, consult your Toyota dealer.

However, now and then, you may notice light knocking for a short time while accelerating or driving up hills. This is no cause for concern.

Fuel tank capacity:

41 liters (9.0 Imp. gal.)

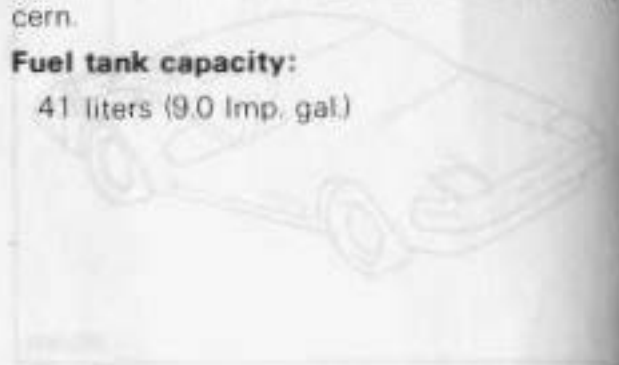

Operation in foreign countries

If you plan to drive your Toyota in another country...

First, comply with the vehicle registration laws.

Second, confirm the availability of the correct fuel.

Tips for driving the first 1000 km (600 miles)



Drive gently and avoid high speeds.

You need not follow a break-in schedule with your new Toyota. But following a few simple tips for the first 1000 km (600 miles) can add to the future economy and long life of your vehicle:

- Do not drive over 100 km/h (62 mph).
- Maintain engine speed between 2000 and 4000 rpm.
- Avoid full-throttle starts.
- Try to avoid hard stops during the first 300 km (200 miles).
- Do not drive slowly with the transmission in a high gear.
- Do not drive for a long time at any single speed, either fast or slow.
- Do not tow a trailer during the first 800 km (500 miles).

Keys

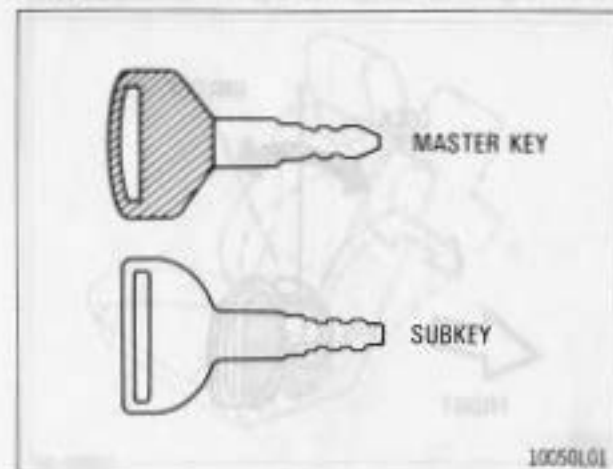

The master key works in every lock. The subkey will not work in the rear trunk and glovebox.

To protect things locked in the rear trunk or glovebox when you have your vehicle parked, leave the subkey with the attendant.

Since the doors and rear trunk lid can be locked without a key, you should always carry a spare master key in case you accidentally lock your keys inside the vehicle.

Door locks— Locking and unlocking with key

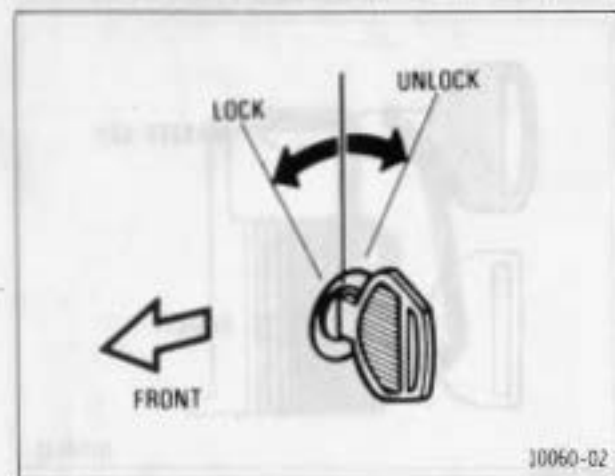

Turn the key towards the front of the vehicle to lock and towards the back to unlock.

Vehicles with a power door lock system—Locking or unlocking one door locks or unlocks the other.

Locking from the inside

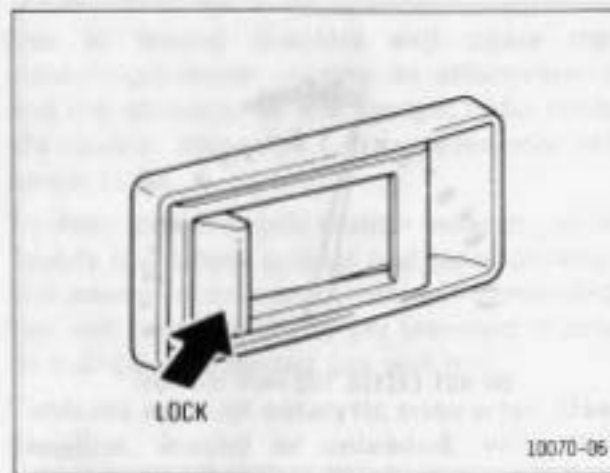

After closing the door, push in the lock lever.

The door then cannot be opened with either the outside or inside door handle.

Before driving, be sure that the doors are closed and locked, especially when small children are in the vehicle. Along with the proper use of seat belts, locking the doors helps prevent the driver and passengers from being thrown out from the vehicle during an accident. It also helps prevent the doors from being opened unintentionally.

Locking from the outside without key

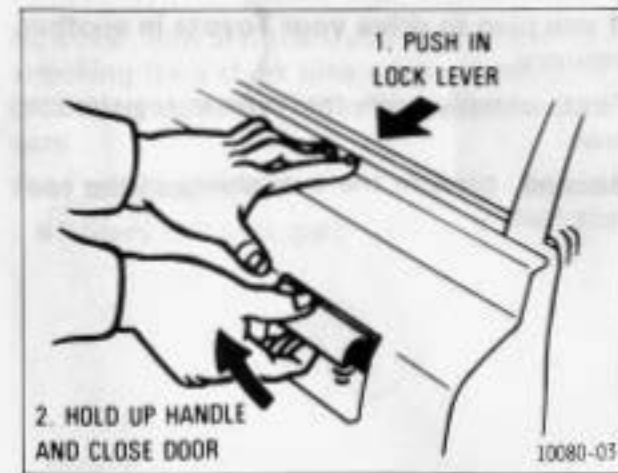

Push in the lock lever. Then hold up the handle as you close the door.

Be careful not to lock your keys in the vehicle.

Vehicles with power door lock system sold in Australia—If the key is left in the ignition switch, the driver's side door cannot be locked. This is a feature designed to avoid locking the key accidentally in the vehicle.

Power door lock switch

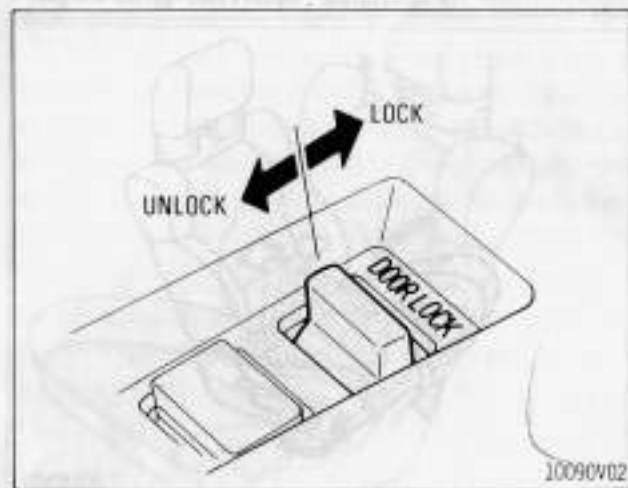

To lock and unlock all the side doors simultaneously, push the switch.

Seats— Adjusting seat position



Pull the lock release lever up. Then slide the seat to the desired position with slight body pressure and release the lever.

After adjusting the seat, try sliding it forward and backward to make sure it is locked in position.

This adjustment should not be made while the vehicle is moving, as the seat may unexpectedly move and cause the driver to lose control of the vehicle.

Do not place anything under the seats. It might interfere with the seat-lock mechanism.

Adjusting seatback angle

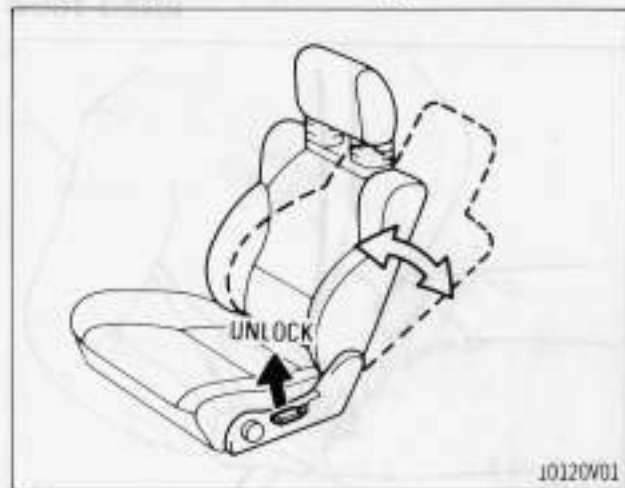

Lean forward and pull the lock release lever. Then lean back to the desired angle and release the lever.

After adjusting the seatback, exert body pressure to make sure it is locked in position.

This adjustment should not be made while the vehicle is moving, as the seatback may unexpectedly move backward and cause the driver to lose control of the vehicle.

Adjusting side supports



Turn the knob either way.

This adjustment should not be made while the vehicle is moving.

Adjusting seat cushion angle



Turn the knob either way.

This adjustment should not be made while the vehicle is moving.

To reduce the risk of sliding under the lap belt during a collision, **avoid reclining the seatback any more than needed.** The seat belts provide maximum protection when the driver and the passenger are sitting well back and straight up in the seats. If you are reclined, the lap belt may slide past your hips and apply restraint forces directly to the abdomen. Therefore, in the event of a frontal collision, the risk of personal injury may increase with increasing recline of the seatback.

Adjusting lumbar support

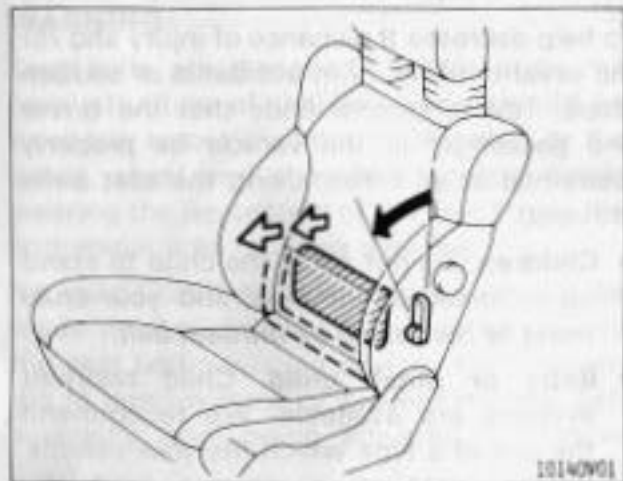

Pull the lever forward and release.

Repeat this until you achieve the desired amount of support.

Headrests

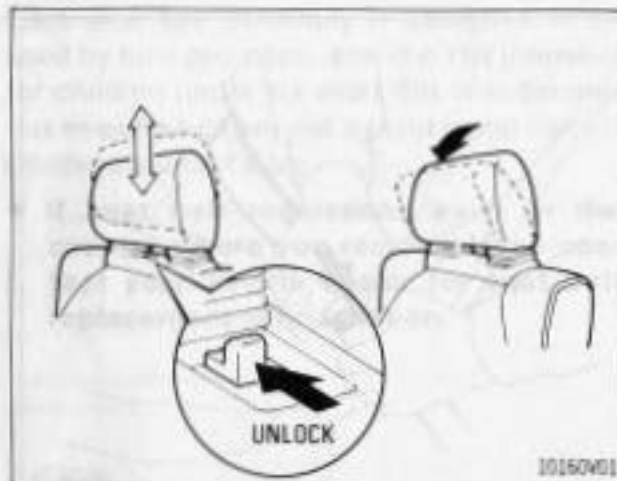

To raise the headrest, pull it up. To lower it, press the lock release button and push the headrest down. To move the headrest forward, pull on the top.

Pulling the top of the headrest as far as it can go will return it to the upright position.

Adjust the top of the headrest so that it is closest to the top of your ears, and lock it into position. Do not drive with the headrests removed.

The headrest is most effective when it is close to your head. Therefore, using a cushion on the seatback is not recommended.

Seat belts



Adjust the seat as needed and sit well back in the seat and straight up. To fasten your belt, pull it out of the retractor and insert the tab into the buckle.

You will hear a click when the tab locks into the buckle. Make sure that the connection is secure and the belt is not twisted.

The seat belt length automatically adjusts to your size and the seat position.

The retractor will lock the belt during a sudden stop or on impact. It also may lock if you lean forward too quickly. A slow, easy motion will allow the belt to extend, and you can move around freely.

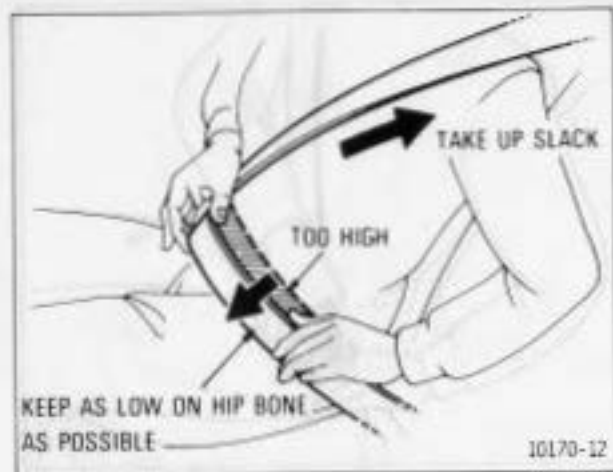

Adjust the position of the lap and shoulder belts.

Position the lap belt as low as possible on your hips—not on your waist, then adjust it to a snug fit by pulling the shoulder portion upward through the latch plate. Failure to do so could increase the chance of injury due to sliding under the lap belt during an accident.

For your safety, do not place the shoulder belt under your arm.



To release the belt, press the buckle-release button and allow the belt to retract.

If the belt does not fully retract, pull it out and check for kinks or twists. Then make sure that it remains untwisted as it retracts.

Seat belt tips

To help decrease the chance of injury and /or the severity of injury in accidents or sudden stops, Toyota recommends that the driver and passenger in the vehicle be properly restrained at all times, using the seat belts provided.

- Children.** Do not allow the child to stand up or kneel on the seat, and *your child must be restrained by the seat belt.*
- Baby or small child.** Child restraint systems are available. We recommend the use of a type which fits your vehicle. Before installation, always read the manufacturer's instructions.
- Pregnant woman.** Toyota recommends the use of a seat belt. Ask your doctor for specific recommendations. The lap belt should be worn securely and as low as possible over the hips and not on the waist.
- Injured person.** Toyota recommends the use of a seat belt. Depending on the injury, however, first check with your doctor.
- The driver and passenger should fasten their seat belts whenever the vehicle is moving.**

Combustion ignition switch
and steering lock.

WARNING:

Seat belts are designed to bear upon the bony structure of the body, and should be worn low across the front of the pelvis, or the pelvis, chest and shoulders, as applicable; wearing the lap section of the belt across the abdominal area must be avoided.

No modifications and additions should be made by the user which will either prevent the seat belt adjusting devices from operating to remove slack, or prevent the seat belt assembly from being adjusted to remove slack.

Seat belts should be adjusted as firmly as possible, consistent with comfort, to provide the protection for which they have been designed. A slack belt will greatly reduce the protection afforded to the wearer.

Care should be taken to avoid contamination of the webbing with polish, oils and chemicals, and particularly battery acid. Cleaning may safely be carried out using mild soap and water. The belt should be replaced if webbing becomes frayed, contaminated or damaged.

It is essential to replace the belt assembly and to inspect the belt anchorages after it has been worn in a severe impact even if damage to the belt assembly is not obvious. Belts should not be worn with straps twisted.

Each seat belt assembly is designed to be used by only one occupant; it is not intended for children under six years old. It is dangerous to put a belt around a child being carried on the occupant's lap.

- **If seat belt regulations exist in the country where you reside, please contact your Toyota dealer for seat belt replacement or installation.**

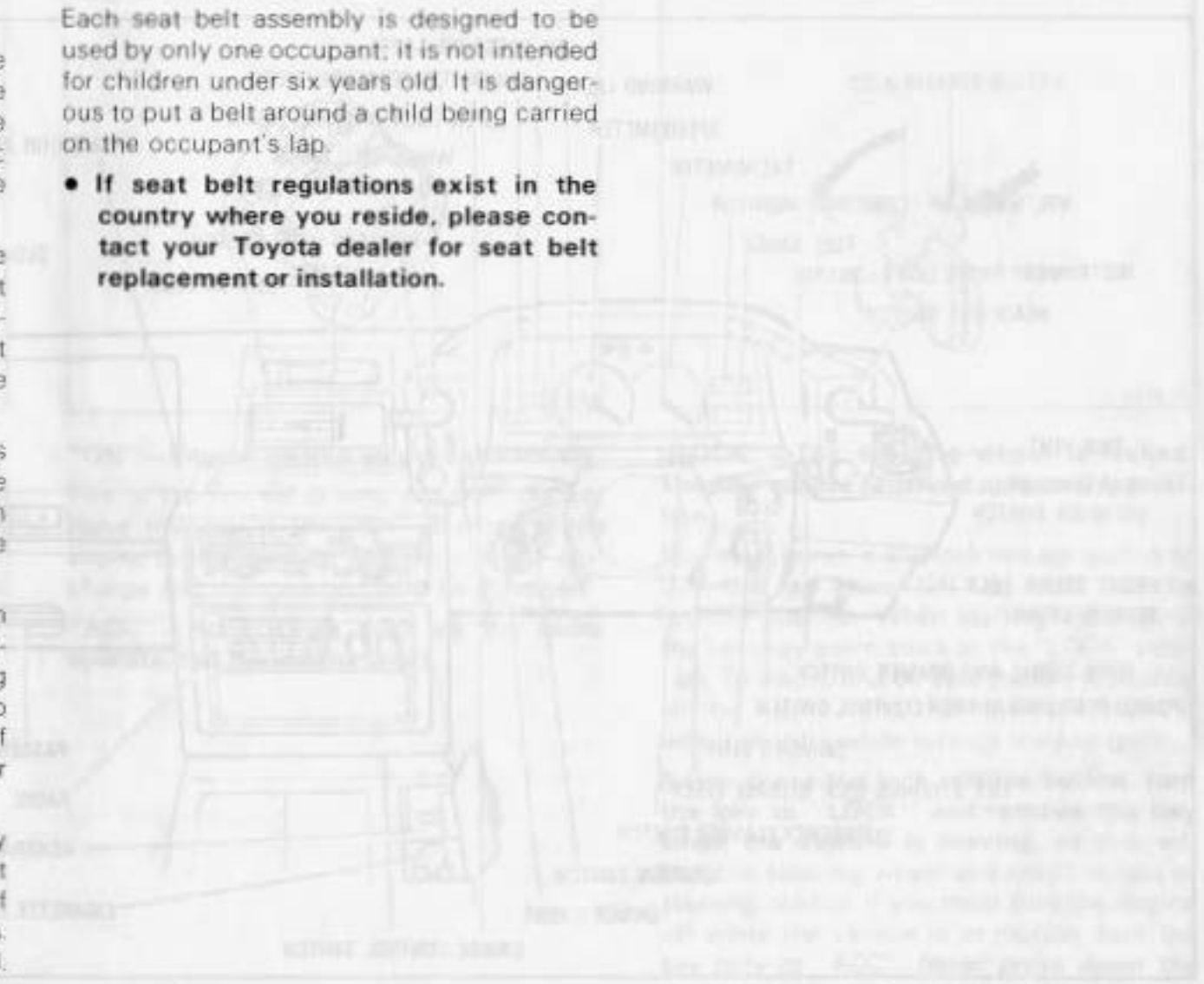

Overview of the instruments and controls

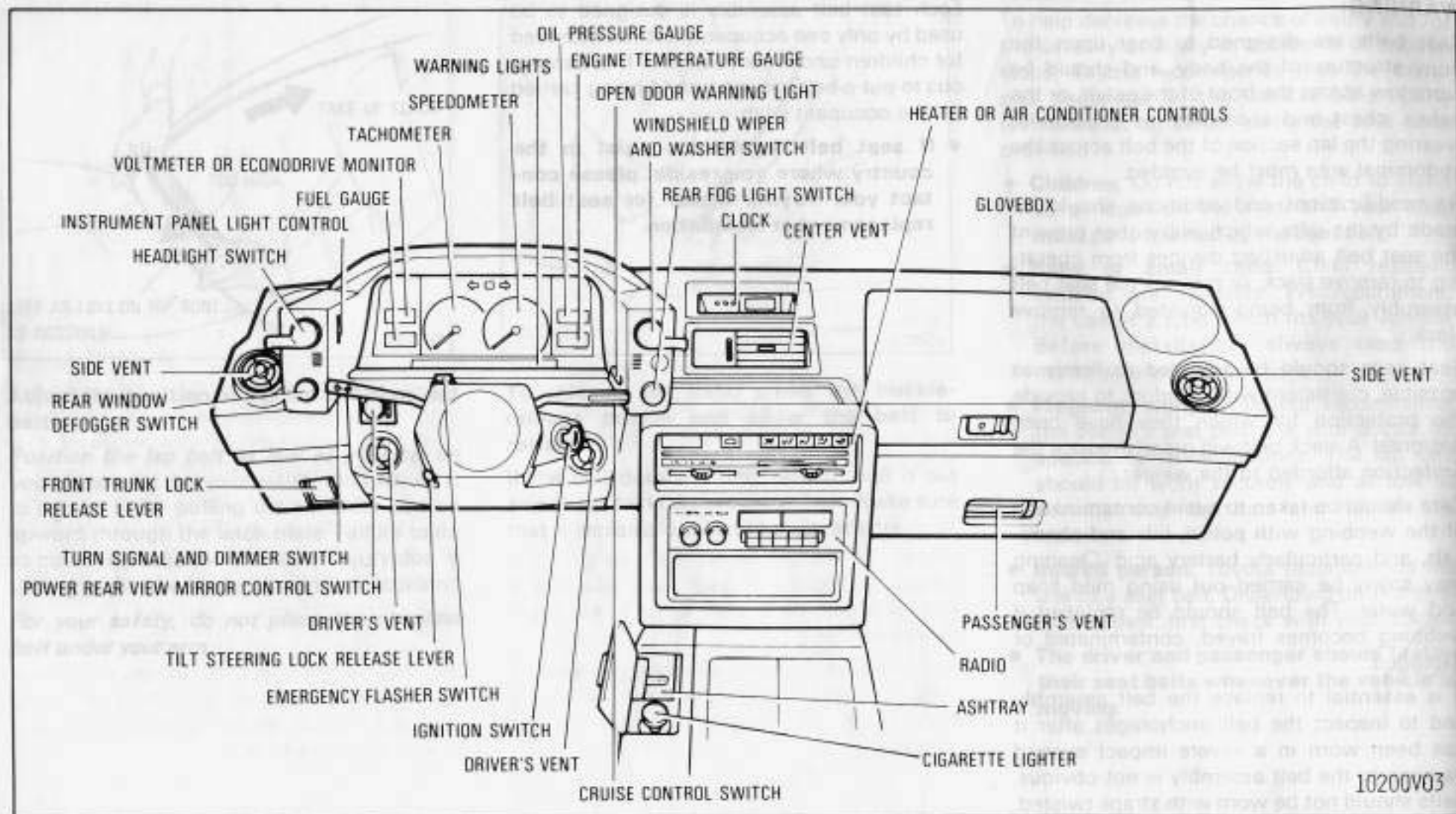

10200V03

Combination ignition switch and steering lock



"START" – Starter motor on.

Before starting, place the transmission in neutral and depress the clutch pedal. As soon as the engine starts, release the key. It will return to the "ON" position. Do not crank the starter continuously for more than 15 seconds. (For starting tips, see Section 2.)

Tilt steering wheel



"ON" – Engine on and all accessories on.

This is the normal driving position. *Do not leave the key in the "ON" position if the engine is not running.* The battery will discharge and the ignition could be damaged.

"ACC" – Accessories such as the radio operate, but the engine is off.

Emergency flasher (hazard) lights



"LOCK" – The steering wheel is locked. The key can be removed only at this position.

You must press in the lock release button to turn the key from "ON" or "ACC" to the "LOCK" position. When starting the engine, the key may seem stuck at the "LOCK" position. To free it, first be sure the key is pushed all the way in, and then rock the steering wheel slightly while turning the key gently.

Never press the lock release button, turn the key to "LOCK" and remove the key when the vehicle is moving, as this will lock the steering wheel and result in loss of steering control. If you must turn the engine off while the vehicle is in motion, turn the key only to "ACC". Never press down the lock release button and remove the key.

Headlight switch

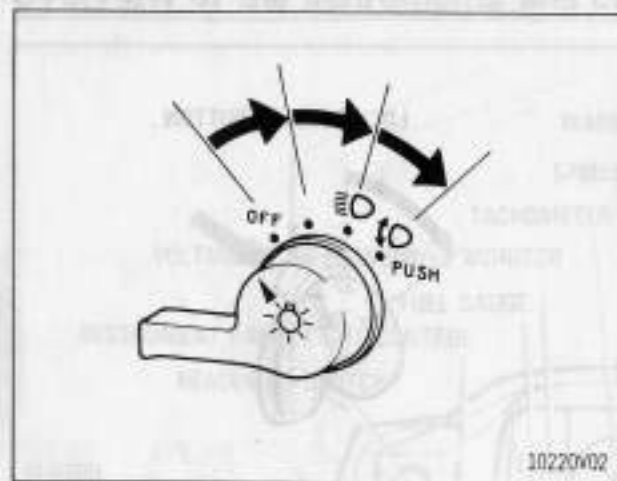

To turn the lights on, twist the switch.

FIRST CLICKSTOP: Only the parking, tail, license plate and instrument panel lights turn on. On vehicles sold in the United Kingdom, the headlights also turn on at reduced intensity when the ignition switch is on.

SECOND CLICKSTOP: The headlights also turn on.

THIRD CLICKSTOP: The headlights and all the above lights turn off with the headlights raised. You must push in the switch to turn it to this position:

On vehicles sold in Europe and Australia, the buzzer will remind you to turn the lights off when the driver's door is opened if the ignition switch is turned to the "LOCK" position with the headlight switch on.

If there is a possibility that the retractable system could freeze, keep the headlights in the raised position.

If the headlights are frozen, do not attempt to raise or retract them but wait until the system thaws out.

If the headlight retractable system does not operate, see Section 3 for emergency information.

Combination headlight dimmer and turn signal switch

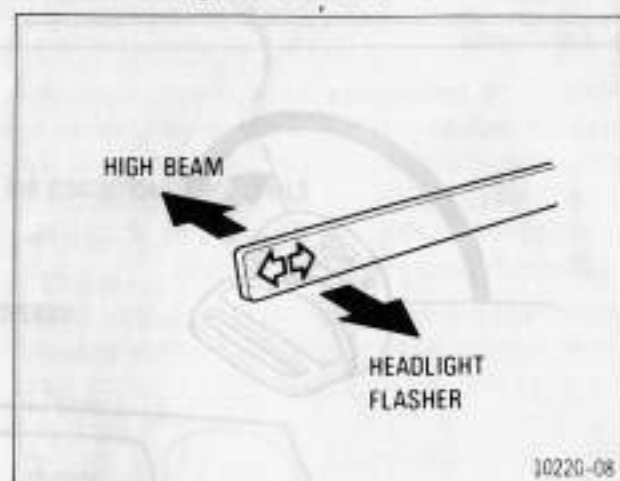

For high beam, push the lever forward. Pull it back for low beam. To operate the headlight flasher, pull the lever all the way back and hold it. The headlights will rise and come on.

By pulling and releasing the lever repeatedly, you can flash the headlights. They will automatically retract after the lever is released.

A blue light on the dashboard indicates high beam.

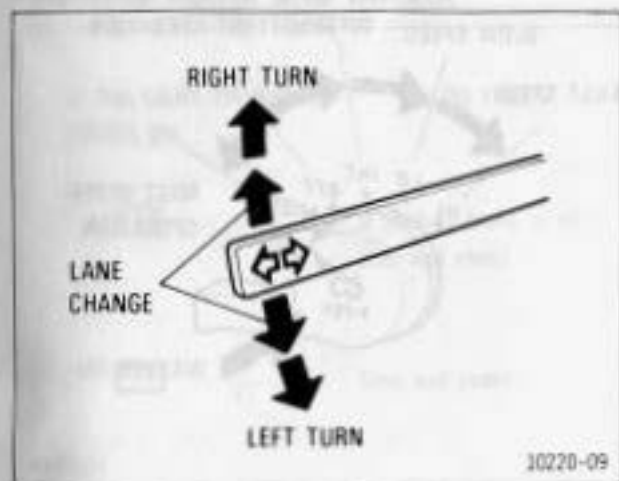

For signaling turns, move the lever up or down in the conventional manner.

The turn signal is self-cancelling after a turn, but after a lane change, you may have to cancel it by hand. You can also signal a lane change by moving the turn signal lever part-way and holding it there. If the green dashboard light flashes faster than normal, it indicates that the front or rear turn signal bulb has burned out. If the dashboard light does not come on, the fuse or the indicator light itself has probably failed. You may change headlight beam even while the turn signal lights are flashing.

Tilt steering wheel

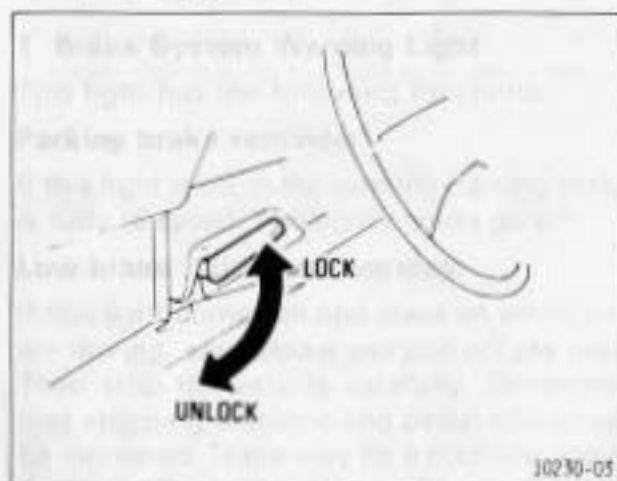

To change the steering wheel height, push down the lock release lever, tilt the steering wheel to the desired height and pull the lever up to its original position.

After adjusting the steering wheel, try moving it up and down to make sure it is locked in position.

Never make this adjustment while the vehicle is moving.

Emergency flasher switch

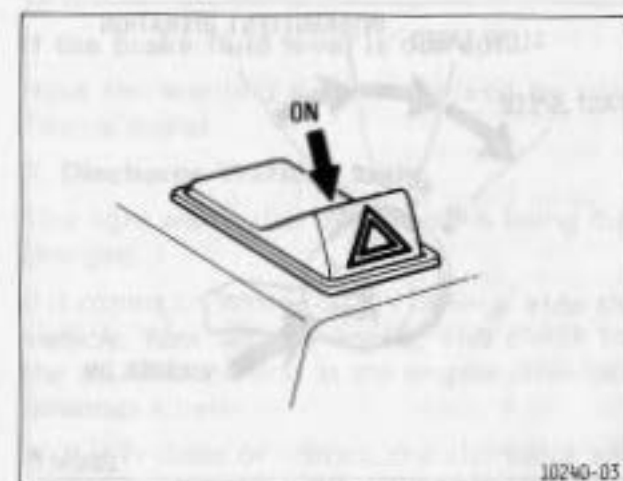

To turn on the emergency warning lights, push the switch down.

All the turn signal lights will flash. The emergency warning lights will work with the engine running or off without the ignition key.

Turn on the emergency flashers to warn other drivers if your vehicle must be stopped where it might be a traffic hazard.

Always pull as far off the road as possible.

The turn signal lights will not work when the emergency flashers are operating.

Windshield wiper and washer switch – Intermittent type without "MIST" position

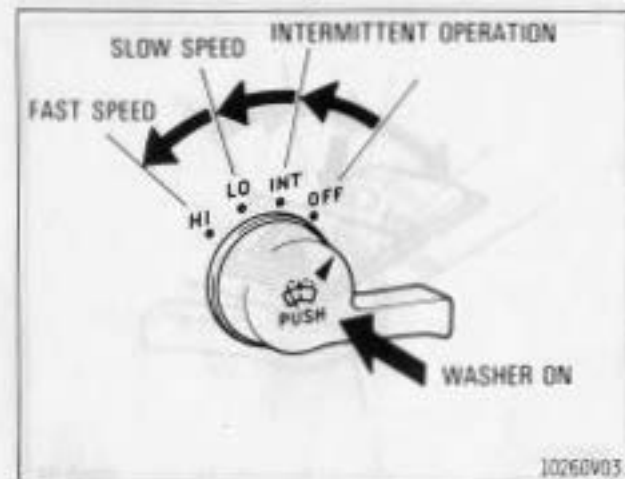

To turn the wipers on, turn the switch. To make the washer squirt, push the switch in.

The wipers will operate at intervals when the switch is in the "INT" position.

Also, the wipers will automatically operate a couple of times after the washer squirts even with the switch in the "OFF" position.

Do not operate the wipers if the windshield is dry. It may scratch the glass.

If the washer does not work, check to see whether the washer tank is empty. For information on adding washer fluid, see "Adding washer fluid" in Section 6.



In cold weather, warm the windshield with the defroster before using the washer. This will help prevent icing, which could block your vision.



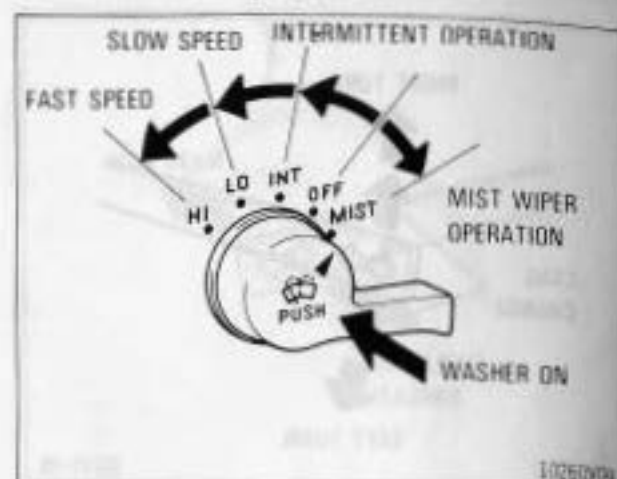

Intermittent type with "MIST" position



For a single wipe, turn the switch to the "MIST" position for a second and release it.

The switch will return to the "OFF" position when you release it. The wipers keep operating if the switch is held in the "MIST" position.

Warning lights and buzzer

IF THE LIGHT OR BUZZER COMES ON	DO THIS.
1 	If parking brake is off, stop and check.
2 	Stop and check.
3 	Take vehicle to Toyota dealer.
4 Low fuel level warning light	Fill up the tank.
5 DOOR	Close all doors.
6 	Take vehicle to Toyota dealer.
7 > Light reminder buzzer	Turn off lights.

1. Brake System Warning Light

This light has the following functions:

Parking brake reminder

If this light is on, make sure the parking brake is fully released. The light should go off.

Low brake fluid level warning

If this light comes on and stays on while you are driving, *slow down and pull off the road*. Then stop the vehicle carefully. Remember that stopping distance and pedal effort may be increased. There may be a problem somewhere in the brake system. Check the fluid level of the see-through reservoir.

NOTE: To make sure that the parking brake has not caused the warning light to come on, check to see that the parking brake is fully released.

If the brake fluid level is low...

At a safe place, test your brakes by starting and stopping.

- If you judge that the brakes still work adequately, drive *cautiously* to your nearest dealer or shop for repairs. **Continued normal driving is dangerous.**
- If the brakes are not working, have the vehicle towed in for repairs. (For towing information, see Section 3.)

If the brake fluid level is correct...

Have the warning system checked by your Toyota dealer.

2. Discharge Warning Light

This light warns that the battery is being discharged.

If it comes on while you are driving, *stop the vehicle, turn off the engine*, and check for the cause. Look first at the engine drive belt (alternator belt).

- If it is loose or broken, the alternator will not charge the battery properly.
- If the belt is OK, there is a problem somewhere in the charging system.

The engine ignition will continue to operate, however, until the battery is discharged. Turn off the air conditioner, blower, radio, etc., and drive directly to the nearest Toyota dealer or repair shop.

Do not continue driving if the engine drive belt (alternator belt) is broken or loose.

3. Engine Electrical System Warning Light

This light warns that there is a problem somewhere in your engine electrical system.

If it comes on while you are driving, have your vehicle checked by your Toyota dealer as soon as possible.

4. Low Fuel Level Warning Light

This light comes on when the fuel level in the tank becomes nearly empty. Fill up the tank as soon as possible.

5. Open Door Warning Light

This light remains on until all the side doors are completely closed.

6. Engine Compartment Cooling Fan Warning Light

This light warns that there is a problem somewhere in the engine compartment cooling fan system.

If this light comes on while you are driving, slow down and take your vehicle to the nearest Toyota dealer or qualified repair shop for a repair. *Do not drive over 60 km/h (37 mph).*

7. Light Reminder Buzzer (vehicles sold in Europe and Australia)

This buzzer will sound when the driver's door is opened if the ignition switch is turned to the "LOCK" position with the headlight switch on. Removing the key will not stop the buzzer as long as the headlight switch is on.

How to check all the warning lights (except the low fuel level warning light):

1. Apply the parking brake.
2. Open one of the side doors.
The open door warning light should come on.
3. Close the side door.
The open door warning light should go off.
4. Turn the ignition key to "ON", but do not start the engine.

All the warning lights except the open door warning light and low fuel level warning light should come on.

If any warning light does not function, either the bulb is burned out or the circuit is in need of repair. Have it checked as soon as possible.

Brake pad wear indicators

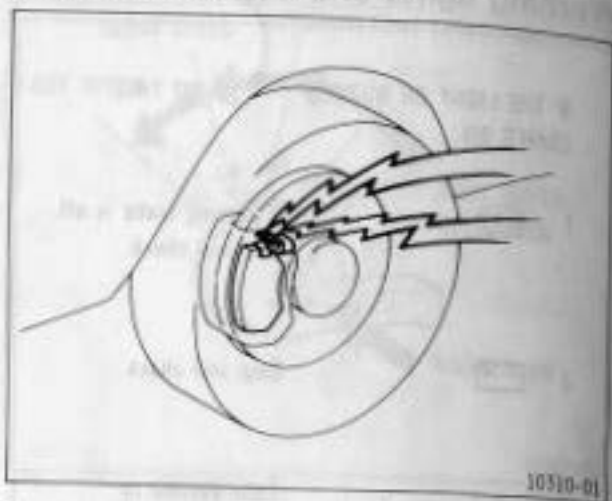

The brake pad wear indicators on your disc brakes give a warning noise when the brake pads are worn to where replacement is required.

If you hear a squealing or scraping noise while driving, have the brake pads checked and replaced by your nearest Toyota dealer immediately.

Avoid continuous driving with the warning noise.

Continuous driving without replacing the brake pads will cause expensive rotor damage and increasing brake pedal effort to get the same stopping distance.

Fuel gauge

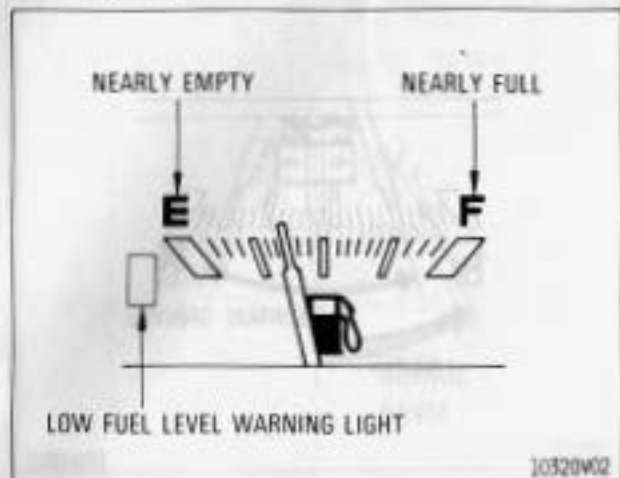

The gauge works when the ignition switch is on and indicates approximate quantity of fuel remaining in the tank.

It is a good idea to keep the tank over 1/4 full.

This fuel gauge has a non-return type needle. Therefore, the needle will remain at the indicated fuel level position regardless of the position of the ignition switch.

Do not drive with the fuel level below the "E" or with the low fuel level warning light on. It may cause engine misfire, and damage to the catalytic converter.

Engine temperature gauge

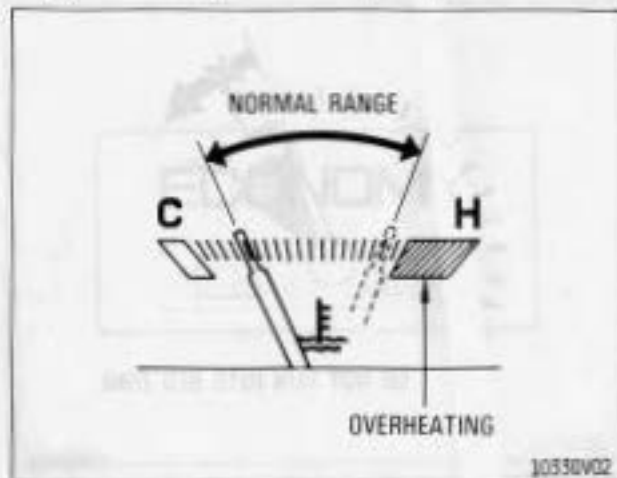

The gauge indicates the engine coolant temperature when the ignition switch is on. The engine operating temperature will vary with changes in weather and engine load.

If the needle points to the red zone or higher, stop your vehicle and allow the engine to cool.

Your vehicle may overheat during severe operating conditions, such as:

1. Driving up a long hill on a hot day.
2. Reducing speed or stopping after high speed driving.
3. Idling for a long period with the air conditioner on in stop-and-go traffic.
4. Towing a trailer.

Clock



5. Lugging the engine by driving slowly in a high gear.

Do not remove the thermostat in the engine cooling system as this may cause the engine to overheat. The thermostat is designed to control the flow of coolant to keep the temperature of the engine within the specified operating range.

Do not continue driving with an overheated engine. See "If your vehicle overheats" in Section 3.

Odometer and trip meter

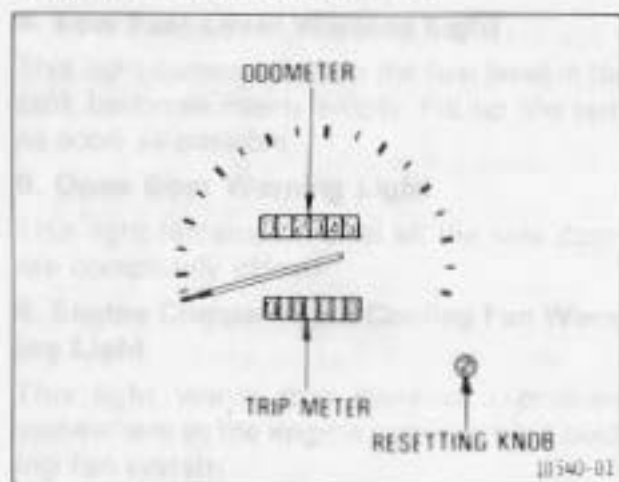

The odometer records the total distance the vehicle has been driven. The trip meter may be set to zero to record the distance on each trip. To set the trip meter, press the knob in and release it.

The black digits in white indicate tenths of kilometers or miles.

Tachometer



The tachometer indicates engine speed in thousands of rpm (revolutions per minute). Use it while driving to select correct shift points and to prevent engine lugging and overrevving.

Driving with the engine running too fast causes excessive engine wear and poor fuel economy. Remember, in most cases the slower the engine speed, the greater the fuel economy.

Do not run the needle into the red zone. This may cause severe engine damage.

Oil pressure gauge

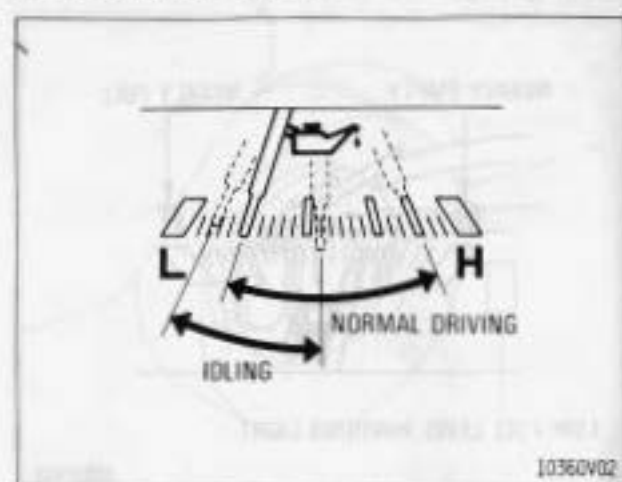

The oil pressure gauge indicates engine oil pressure when the ignition is on. Check it while driving to make sure that the needle is in the proper range.

If the oil pressure should stay below the normal range, **pull off the road to a safe place and stop the engine immediately.** Call a Toyota dealer or qualified repair shop for assistance.

Do not drive the vehicle until the cause is fixed—it may ruin the engine.

Oil pressure may not build up when the oil level is too low. The oil pressure gauge is not designed to indicate oil level, and the oil level must be checked using the level dipstick.

Voltmeter

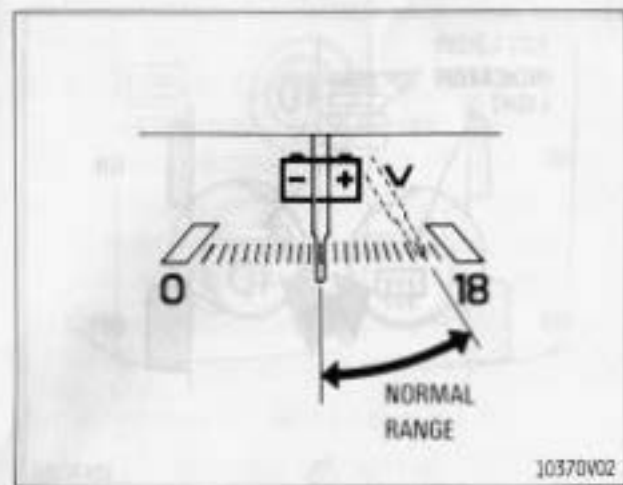

The voltmeter tells whether the battery is charged or discharged. Check it while the engine is running—the needle should always indicate as shown above.

If the needle reads below or above the normal range while the engine is running, it indicates the charging system needs immediate repair.

However, it is normal for the needle to drop below the normal range during engine starting.

Econodrive monitor



The econodrive monitor keeps you informed of your fuel economy by the color. For best fuel economy, try to keep it in the green.

An amber color indicates increased fuel consumption. Accelerating slowly and smoothly will help keep it in the green.

Clock

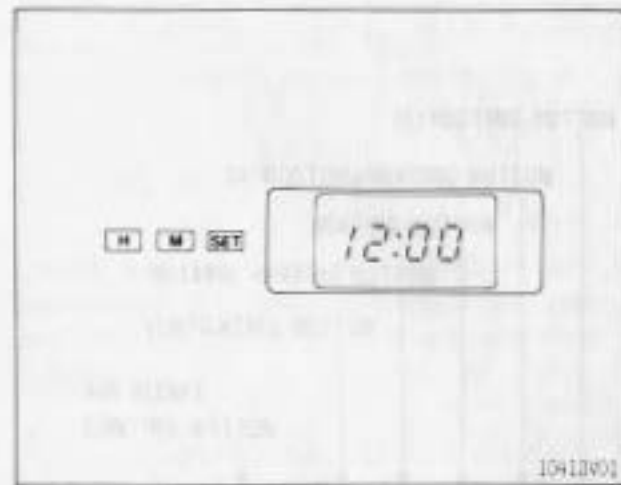

The digital clock indicates the time with the ignition key at the "ACC" or "ON" position.

When the tail lights are turned on, the brightness of the time indication will be reduced.

To reset the hour, depress the "H" button.

To reset the minute, depress the "M" button.

To adjust the time to an even hour, depress the "SET" button. For example, if the button is depressed when the time is between 1:01–1:29, the time will change to 1:00. If the time is between 1:30–1:59, the time will change to 2:00.



Once the electrical power source has been disconnected from the clock, the time is automatically set to 1:00 (one o'clock).

Instrument panel light control

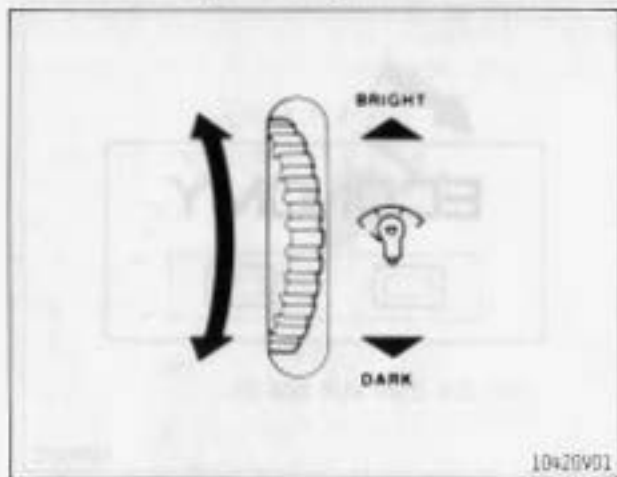

To adjust the intensity of the instrument panel lights, turn the dial.

Rear window defogger switch

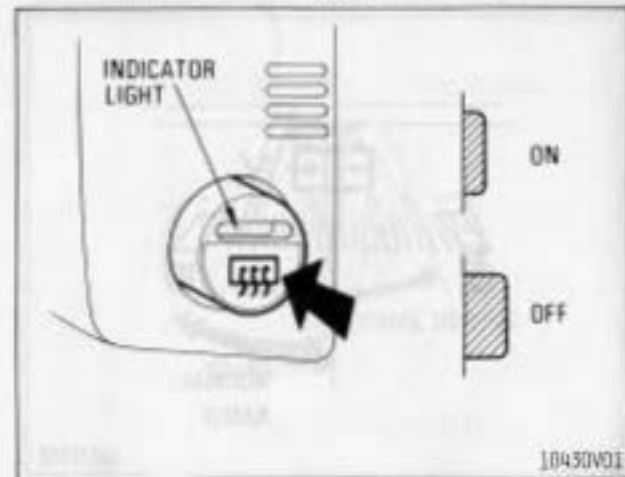

To turn on the electric defogger, push in the switch. Another push will turn it off.

The thin heater wires on the inside of the rear window will quickly clear the window surface. An indicator light will illuminate to indicate the defogger is operating.

Use it only when the engine is running.

When the surface has cleared, push the switch once again to turn the defogger off. Continuous use may cause the battery to discharge, especially during stop-and-go driving. The defogger is not designed for drying rain water or for melting snow.

When cleaning the inside of the rear window, be careful not to scratch or damage the heater wires.

Rear fog light switch

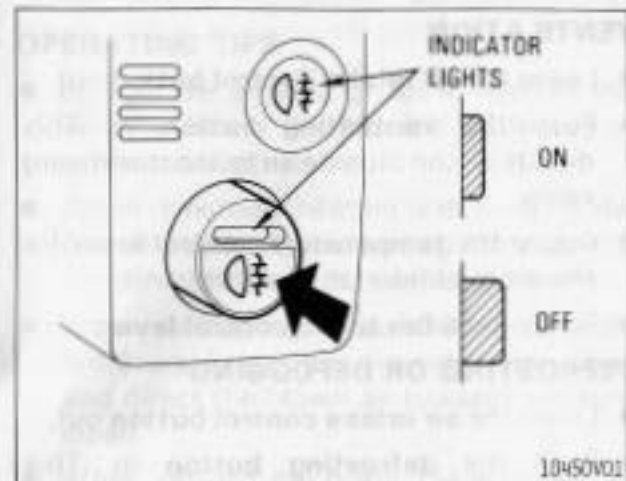

To turn on the rear fog lights, push the switch. They will come on when the headlights are turned on.

Cigarette lighter and ashtray

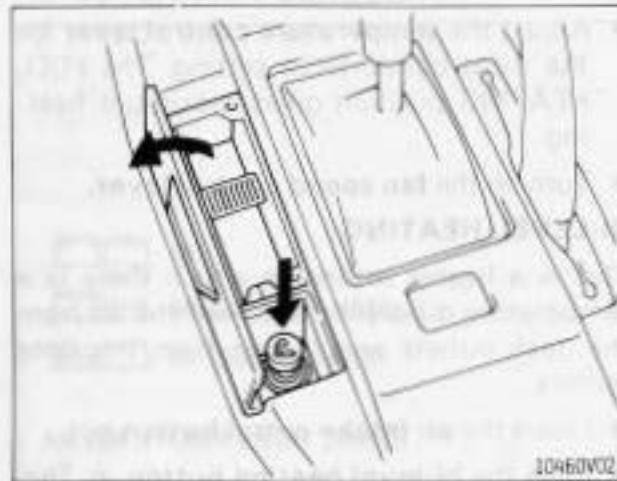

To operate the cigarette lighter, open the ashtray cover and press in the cigarette lighter. When the cigarette lighter becomes heated, it automatically pops out ready for use.

If the engine is not running, the key must be in the "ACC" position.

Do not hold the cigarette lighter pressed in. *After using the ashtray, close the ashtray cover completely.* If not, the flame of a cigarette may cause other cigarette butts to burn, resulting in a fire.

To remove the ashtray, open the ashtray cover and pull out.

Use a Toyota genuine cigarette lighter or equivalent for replacement.

Heater controls

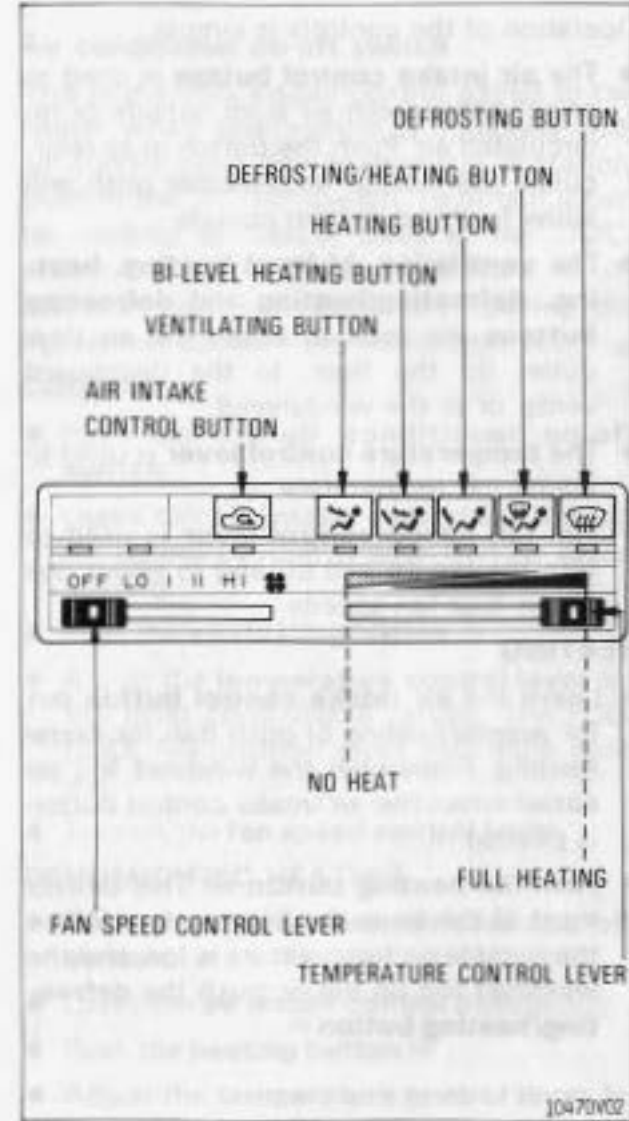

Operation of the controls is simple:

- The **air intake control button** is used to select either fresh air from outside or recirculated air. Push the button in to recirculate the interior air. Another push will allow fresh air in from outside.
- The **ventilating, bi-level heating, heating, defrosting/heating and defrosting buttons** are used to select the air flow outlet (to the floor, to the dashboard vents, or to the windshield).
- The **temperature control lever** is used to adjust the temperature.
- The **fan speed control lever** is used to turn the fan on and off and to select one of the four fan speeds.

HEATING

- Leave the **air intake control button** out for *normal* heating or push it in for *faster* heating. Remember the windows fog up easier when the air intake control button is pushed in.
- Push the **heating button** in. This directs most of the air to the floor outlets. When the outside air temperature is low and the windows fog up easily, push the **defrosting/heating button** in.

- Adjust the **temperature control lever** for the most comfortable setting. The FULL HEATING position gives maximum heating.
- Turn on the **fan speed control lever**.

BI-LEVEL HEATING

This is a heater setting in which there is a temperature difference between the air from the dash outlets and the air from the floor outlets.

- Leave the **air intake control button** out.
- Push the **bi-level heating button** in. This divides the air flow between the dashboard vents and the floor outlets with the air from the floor outlets slightly warmer than that from the dashboard vents. The temperature difference varies from one temperature setting to another.
- Adjust the **temperature control lever** for the most comfortable setting.
- Turn on the **fan speed control lever**.

VENTILATION

- Leave the **air intake control button** out.
- Push the **ventilating button** in. This directs all the outside air to the dashboard vents.
- Adjust the **temperature control lever** for the most comfortable setting.
- Turn on the **fan speed control lever**.

DEFROSTING OR DEFOGGING

- Leave the **air intake control button** out.
- Push the **defrosting button** in. This directs most of the air to the windshield outlets and side vents. Open and adjust the side vents to direct the air flow to the side windows.
- Move the **temperature control lever** to the middle or the FULL HEATING position.
- Set the **fan speed control lever** on high speed. Once the windshield is cleared, the fan speed and heater temperature may be reduced.

OPERATING TIPS

- Be sure the air inlet grilles in front of the windshield are not blocked by leaves or other obstructions.
- When maximum heating is desired for the feet or maximum defrosting force for the windshields, close all dashboard vents.
- When defogging or defrosting the side windows, keep only the side vents open and direct the blown air towards the windows.
- When driving on dusty roads, close all windows and position the air intake control button at leave out position and turn on the fan speed control lever.
- If following another vehicle on a dusty road, or driving in windy and dusty conditions, it is recommended that the air intake control button be temporarily set to push in position, which will close off the outside passage and prevent outside air and dust from entering the vehicle interior.

Air conditioner controls

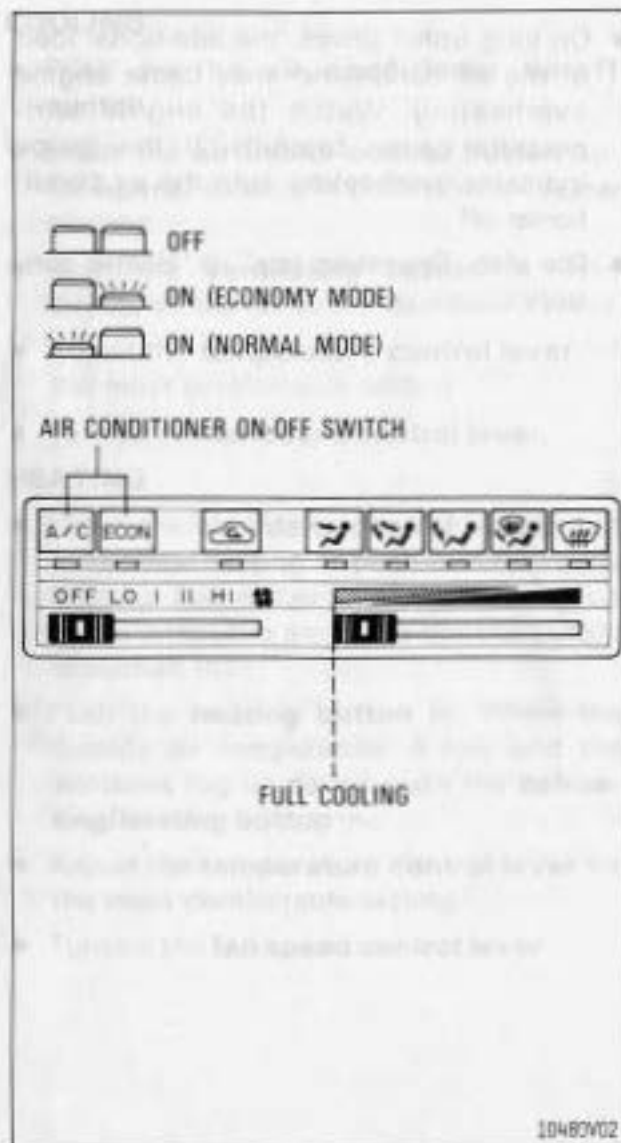

Air conditioner on-off switch

This is the only visible control added to the heater when your vehicle is equipped with air conditioning. For economical operation, push in the "ECON" switch. To obtain a better cooling efficiency, push in the "A/C" switch. As each switch is pushed in, its indicator light will come on. Pushing the lighted switch will turn the system off.

COOLING

- Push on the **air conditioner on-off switch**.
- Leave the **air intake control button** out for *normal* cooling or push it in for *faster* cooling.
- Push the **ventilating button** in.
- Adjust the **temperature control lever** for the most comfortable setting. The FULL COOLING position gives maximum cooling.
- Turn on the **fan speed control lever**.

DEHUMIDIFIED HEATING

- Push on the **air conditioner on-off switch**.
- Leave the **air intake control button** out.
- Push the **heating button** in.
- Adjust the **temperature control lever** for the most comfortable setting.

- Turn on the **fan speed control lever**.

VENTILATION (NO COOLING), HEATING, DEFROSTING OR DEFOGGING

- Push off the **air conditioner on-off switch**.
- Use all the controls in the same way as described in "Heater controls".

OPERATING TIPS

- After parking in the hot sun, drive for the first few minutes with the windows open. After the excess heat has blown away, close the windows to keep out hot air.
- For best cooling efficiency, keep the windows closed.
- Leave the air intake control button out for normal air conditioning. For maximum cooling, push it in. However, since this does not allow fresh air to enter the vehicle, push the button once again from time to time to change the air in the vehicle.
- In extremely humid weather, do not push the defrosting button in during cooling operation. The difference between the temperature of the outside air and that of the windshield could cause the outer surface of the windshield to fog up, blocking your vision.

- On long uphill drives, the additional load of the air conditioner may cause engine overheating. Watch the engine temperature gauge carefully. If the gauge indicates overheating, turn the air conditioner off.
- See also "Operating tips" in "Heater controls".



Automatic air conditioner controls

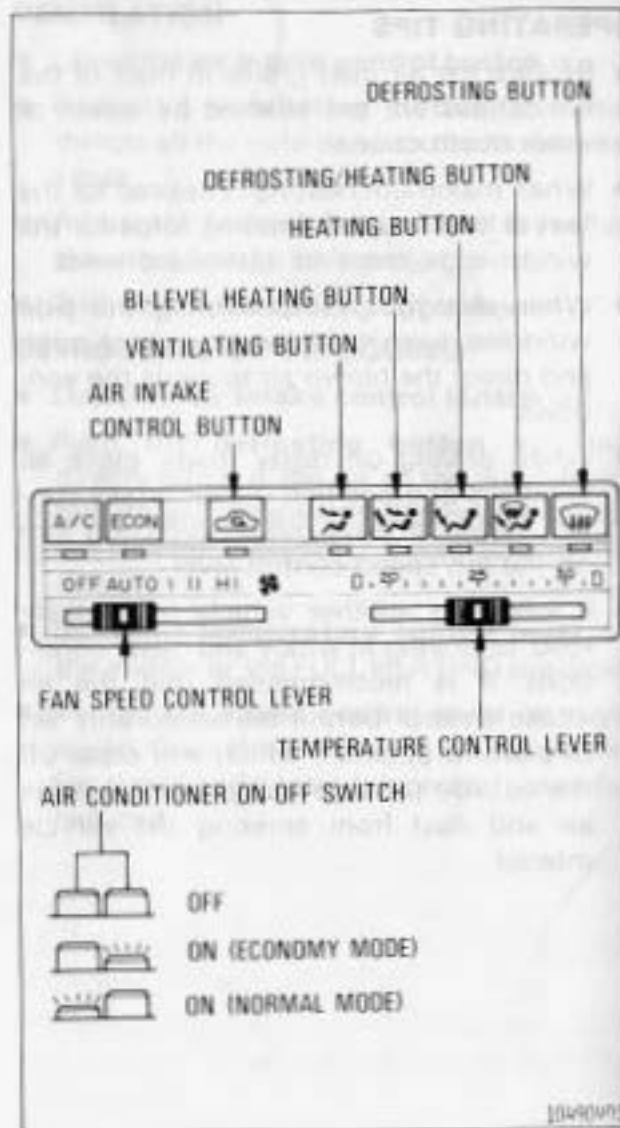

Central vent

This is an air conditioner that automatically maintains the set temperature.

Operation of the controls is simple:

- The **air conditioner on-off switch** is used to turn the air conditioner on and off. For economical operation, push in the "ECON" switch. To obtain a better cooling efficiency, push in the "A/C" switch. As each switch is pushed in, its indicator light will come on. Pushing the lighted switch will turn the system off.
- The **air intake control button** is used to select either fresh air from outside or recirculated air.
- The **ventilating, bi-level heating, heating, defrosting/heating** and **defrosting buttons** are used to select the air flow outlet (to the floor, to the dashboard vents, or to the windshield).
- The **temperature control lever** is used to adjust the temperature. The figures on the panel indicate the temperature.
- The **fan speed control lever** is used to turn the fan on and off and to select the fan speeds. In the "AUTO" position, the fan delivers the most suitable amount of air at the temperature you have selected.

Car auto

Before operating

COOLING

- Push on the **air conditioner on-off switch**.
- Leave the **air intake control button** out for *normal* cooling or push it in for *faster* cooling.
- Push the **ventilating button** in. This directs all the air to the dashboard vents.
- Adjust the **temperature control lever** for the most comfortable setting.
- Turn on the **fan speed control lever**.

HEATING

- Leave the **air intake control button** out for *normal* heating or push it in for *faster* heating. Remember the windows fog up easier when the air intake control button is pushed in.
- Push the **heating button** in. When the outside air temperature is low and the windows fog up easily, push the **defrosting/heating button** in.
- Adjust the **temperature control lever** for the most comfortable setting.
- Turn on the **fan speed control lever**.

- If desired, push on the **air conditioner on-off switch**. Dehumidified air will be delivered with decreased heating efficiency.

BI-LEVEL HEATING

This is a heater setting in which there is a temperature difference between the air from the dashboard vents and the air from the floor outlets.

- Push off the **air conditioner on-off switch**.
- Leave the **air intake control button** out.
- Push the **bi-level heating button** in. This divides the air flow between the dashboard vents and the floor outlets with the air from the floor outlets slightly warmer than that from the dashboard vents. The temperature difference varies from one temperature setting to another.
- Adjust the **temperature control lever** for the most comfortable setting.
- Turn on the **fan speed control lever**.

VENTILATION

- Push off the **air conditioner on-off switch**.
- Leave the **air intake control button** out.
- Push the **ventilating button** in.
- Adjust the **temperature control lever** for the most comfortable setting.
- Turn on the **fan speed control lever**.

DEFROSTING AND DEFOGGING

- Push on the **air conditioner on-off switch**.
- Leave the **air intake control button** out.
- Push the **defrosting button** in. This directs most of the air to the windshield outlets and side vents. Open and adjust the side vents to direct the air flow to the side windows.
- Adjust the **temperature control lever** for the most comfortable setting.
- Turn on the **fan speed control lever**.

OPERATING TIPS

- After parking in the hot sun, drive for the first few minutes with the windows open. After the excess heat has blown away, close the windows to keep out hot air.

- For best cooling efficiency, keep the windows closed.
- Leave the air intake control button out for normal air conditioning. For maximum cooling, push it in. However, since this does not allow fresh air to enter the vehicle, push the button once again from time to time to change the air in the vehicle.
- In extremely humid weather, do not push the defrosting button in during cooling operation. The difference between the temperature of the outside air and that of the windshield could cause the outer surface of the windshield to fog up, blocking your vision.
- On long uphill drives, the additional load of the air conditioner may cause engine overheating. Watch the engine temperature gauge carefully. If the gauge indicates overheating, turn the air conditioner off.
- See also "Operating tips" in "Heater controls".

Side vents

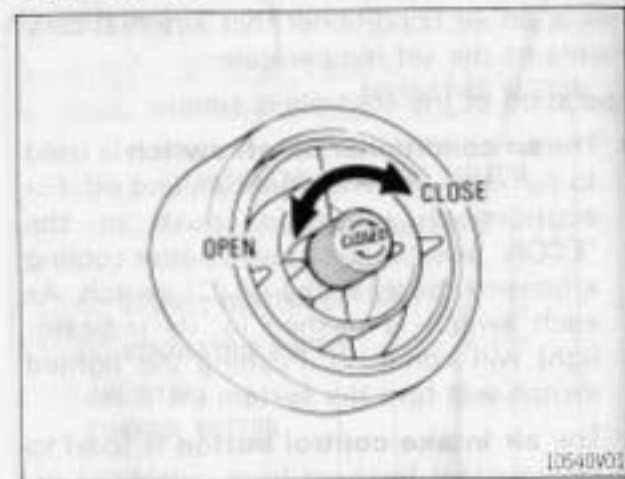

The side vents may be opened or closed as shown.

When defrosting, open and adjust the side vents to direct the air flow to the side windows.

Center vent

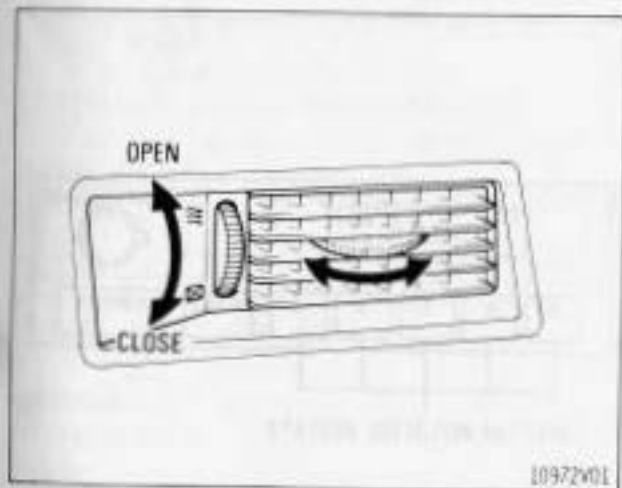

The center vent may be opened or closed as shown.

Car audio— Before operating

You can listen to the car audio when the ignition key is at "ON" or "ACC". However, if the engine is not running, the key must be in the "ACC" position.

RADIO

Adjust the length of your antenna for best reception. Usually a short length is best in large cities and a fully extended antenna is best for distant reception.

FM broadcasts have a range of about 40 km or 25 miles. When driving away from a station you may have to fine-tune your radio and turn up the volume as the station gets weaker. Because FM uses a line-of-sight signal, tall buildings or hills may sometimes block reception. These are all normal characteristics of FM reception and do not indicate any problem with the radio itself.

On some models, the antenna automatically extends to its full height when the radio and ignition are turned on, and retracts when either is turned off.

Before extending the antenna, confirm that there is no one close enough to get poked.

AM-FM three-band radio with electronic tuner (type D)

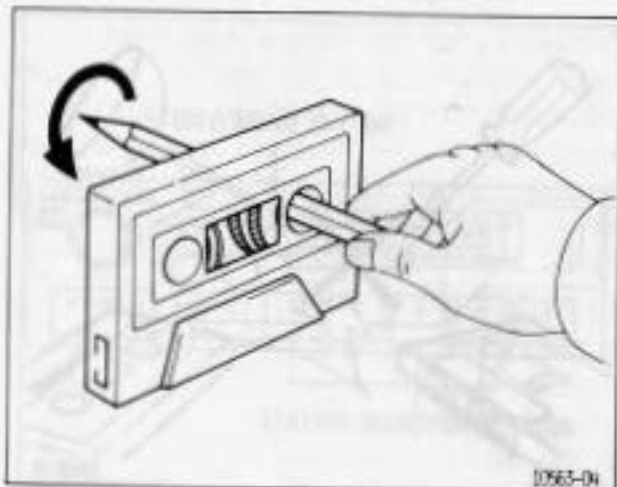

CASSETTE TAPE PLAYER

Use only cassette tapes of good quality, having no damage. Avoid using tapes with a total playing time longer than 90 minutes.

Using damaged tapes would put the tape player into trouble. Longer tapes are not recommended because of their thinness.

Be sure that the tape is not slack and that the label is firmly stuck on the shell before insertion.

Have the tape firmly wound around the tape by turning the hub with a pencil or the like.

Be careful not to touch the disclosed tape surface.

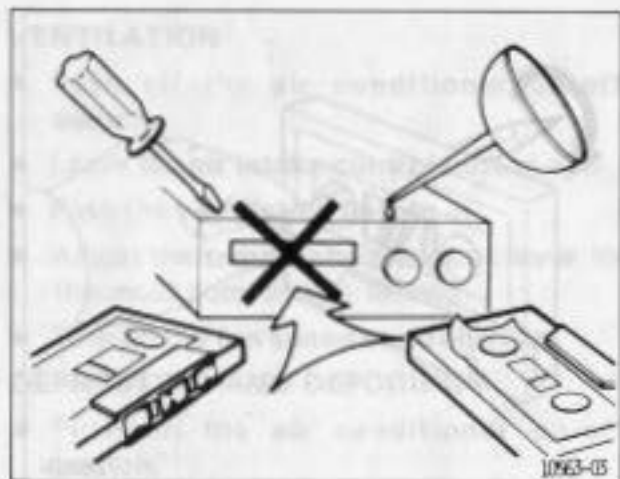

When not in use, take the cassette out of the player, put it back into its case and store it away from dust, magnets and direct sunlight.

Leaving the cassette tapes on the dashboard in the sun could be a good reason for damaged tapes.

Keep the playback head, capstan and pinch roller clean.

Remove tape coating residue accumulated on the head, capstan and pinch roller once or twice a month. A cleaning tape is available on the market.

Do not oil any part of the tape player and do not insert metal goods or a magnet into the slot, or tape player may be damaged.

AM-FM radio

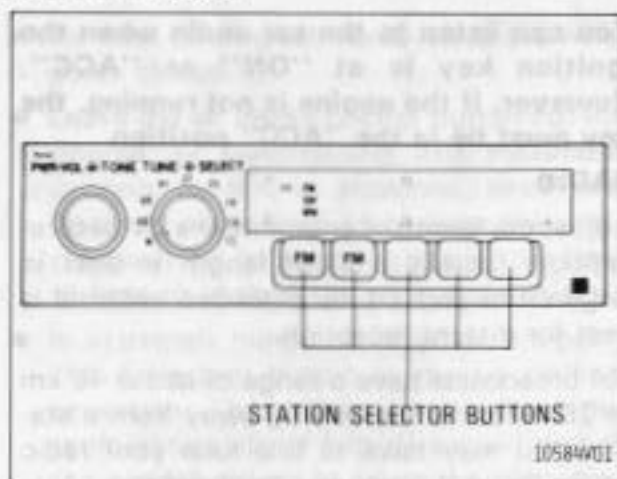

Push the "PWR.VOL" knob to turn the radio on and tune in the desired station with the "TUNE" knob. To receive FM broadcasts, push in one of the "FM" station selector buttons. To receive AM (medium wave and short wave) broadcasts, push in one of the unmarked buttons and turn the "SELECT" knob fully counter-clockwise for medium wave broadcasts or to the proper short wave setting for short wave broadcasts.

To set the station selector buttons:

1. Pull a button out as far as it will go.
2. Tune in the desired station.
3. Push the button in as far as it will go.
4. Repeat this operation for the other buttons.

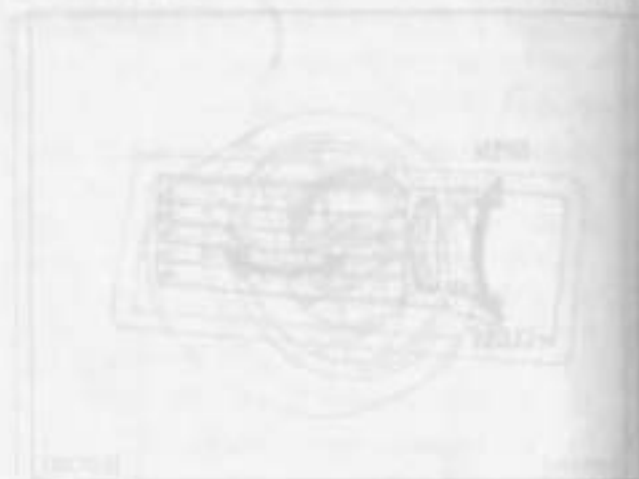

The station selector buttons can be used to preset broadcasts on only one wave at a time.

To adjust the volume, turn the "PWR.VOL" knob.

To adjust the tone, turn the "TONE" knob.

To turn the radio off, push the "PWR.VOL" knob once again.

AM-FM three-band radio with electronic tuner (type A)

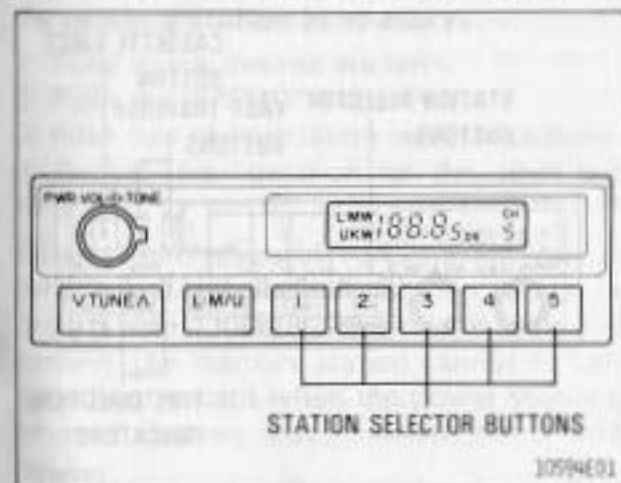

Turn the "PWR.VOL" knob clockwise to turn the radio on. Then push the "L.M/U" button to select either an AM (long wave and medium wave) or FM broadcast and push either side of the "TUNE" button until a beep is heard to tune in the desired station.

Each time you push the "TUNE" button, one after another station is tuned in.

If the "DX" light comes on, the additional boost will assist seeking the weak broadcasts during station searching.

For manual tuning, push either side of the "TUNE" button within 0.5 second.

To retain a station in memory:

1. Tune in the desired station.
2. Push one of the station selector buttons until a beep is heard.
3. Repeat this operation for the other buttons.

Five stations each of AM and FM can be retained in memory but a station can be replaced with a different one by the same procedure. The memory station cannot be cancelled out except when the power source is severed (battery disconnected, burnt fuse, etc.).

To recall a memorized station, push one of the station selector buttons.

To adjust the volume, turn the "PWR.VOL" knob.

To adjust the tone, turn the "TONE" knob.

To turn the radio off, turn the "PWR.VOL" knob fully counterclockwise.

AM-FM three-band radio with electronic tuner (type B)

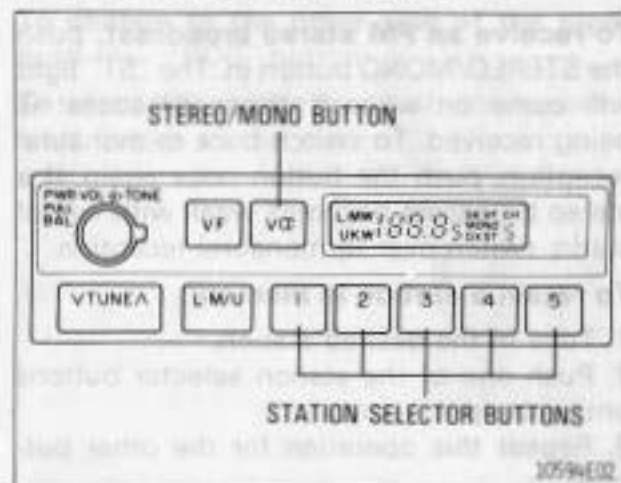

Turn the "PWR.VOL" knob clockwise to turn the radio on. Then push the "L.M/U" button to select either an AM (long wave and medium wave) or FM broadcast and push either side of the "TUNE" button until a beep is heard to tune in the desired station.

Each time you push the "TUNE" button, one after another station is tuned in.

If the "DX" light comes on, the additional boost will assist seeking the weak broadcasts during station searching.

For manual tuning, push either side of the "TUNE" button within 0.5 second.

To receive an FM stereo broadcast, push the STEREO/MONO button in. The "ST" light will come on when a stereo broadcast is being received. To switch back to monaural reception, push the button once again. If a stereo broadcast becomes weak with lots of static, switch over to monaural reception.

To retain a station in memory:

1. Tune in the desired station.
2. Push one of the station selector buttons until a beep is heard.
3. Repeat this operation for the other buttons.

Five stations each of AM (long wave or medium wave) and FM can be retained in memory but a station can be replaced with a different one by the same procedure. The memory station cannot be cancelled out except when the power source is severed (battery disconnected, burnt fuse, etc.).

To recall a memorized station, push one of the station selector buttons.

To adjust the volume, turn the "PWR.VOL" knob.

To balance the sound between the right and left speakers, pull the "PWR.VOL" knob and turn it.

To adjust the tone, turn the "TONE" knob.

To tune in FM stations that broadcast ARI (traffic information) quickly, push in the "VF" button.

The "SK" indicator lights up only when tuning in stations that broadcast ARI regardless of the "VF" button position.

If the "VF" button is pushed in, the "VF" indicator lights up, and the radio will function as follows:

- The frequency indicator will stop only when tuning in an ARI station.
- The alarm will sound if the station gets weaker during receiving an ARI station.
- The volume will be automatically adjusted to a certain volume while receiving ARI even if the volume control is adjusted to the minimum level.
- If the radio has been set for an ARI station, the ARI broadcast will be automatically received even if the cassette tape is playing. The tape sound will go off.

Push in the "VF" button once again to turn off the above functions and to tune in all FM stations.

To turn the radio off, turn the "PWR.VOL" knob fully counterclockwise.

AM-FM radio with electronic tuner and cassette tape player (type A)

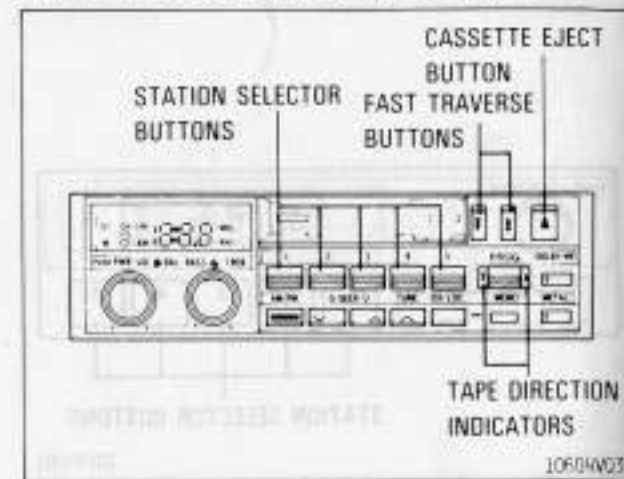

Push the "PWR.VOL" knob to turn the radio on. Then push the "AM/FM" button to select either an AM or FM broadcast and push one of the "SEEK" buttons to tune in the desired station.

Each time you push one of the "SEEK" buttons, one after another station is tuned in.

For manual tuning, push the "TUNE" button.

The radio will change automatically to stereo reception when an FM stereo broadcast is being received. At the same time, the "ST" light will come on. If a stereo broadcast becomes weak with lots of static, the radio will automatically switch over to monaural reception.

AM-FM radio with electronic tuner and cassette tape player (type B)

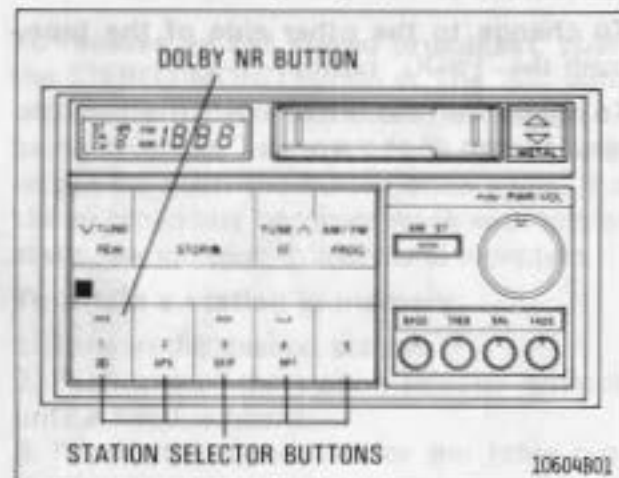

Push the "PWR.VOL" knob to turn the radio on. Then push the "AM/FM (PROG)" button to select either an AM or FM broadcast and push either of the "TUNE (FF)" or "TUNE (REW)" buttons until a beep is heard to tune in the desired station.

Each time you push the button, one after another station is tuned in.

If the "DX" light comes on, the additional boost will assist seeking the weak broadcasts during station searching.

To turn the radio off, turn the "PWR.VOL" knob fully counter-clockwise.

To listen to a cassette tape, simply insert the cassette, with the tape side to the right, into the slot as far as it will go.

For manual tuning, push the "TUNE (FF)" or "TUNE (REW)" button.

The radio will change automatically to stereo reception when an FM stereo broadcast is being received. At the same time, the "ST" light will come on. If a stereo broadcast becomes weak with lots of static, the radio will automatically switch over to monaural reception.

To retain a station in memory:

1. Tune in the desired station.
2. Push one of the station selector buttons until a beep is heard.
3. Repeat this operation for the other buttons.

Five stations each of AM and FM can be retained in memory but a station can be replaced with a different one by the same procedure. The memory station cannot be cancelled out except when the power source is severed (battery disconnected, burnt fuse, etc.).

To recall a memorized station, push one of the station selector buttons.

To turn the radio off, turn the "PWR.VOL" knob fully counter-clockwise.

To listen to a cassette tape, simply insert the cassette, with the tape side to the right, into the slot as far as it will go.

AM-FM radio with electronic tuner and cassette tape player (type B)

To receive an AM stereo broadcast (Motorola type), push the "AM ST" button. The "ST" light will light when a stereo broadcast is being received. Push the button again to return to monaural AM reception. If a stereo broadcast becomes weak, the radio will automatically switch over to monaural reception.

To adjust the volume, turn the "PWR.VOL" knob.

To adjust the high-pitched tone, push the "TREB" knob (if concealed) and turn it.

To adjust the low-pitched tone, push the "BASS" knob (if concealed) and turn it.

To balance the sound between the front and rear speakers, push the "FADE" knob (if concealed) and turn it.

To balance the sound between the right and left speakers, push the "BAL" knob (if concealed) and turn it.

To turn the radio off, push the "PWR.VOL" knob once again.

To listen to a cassette tape, simply insert the cassette, with the tape side to the right, into the slot as far as it will go.

This will automatically turn on the tape player and turn off the radio. The player will automatically change directions at the end of the tape to play the other side.

AM-FM three-band radio

with electronic tuner

and cassette tape player (type B)

When using a tape encoded with Dolby NR*, push the DOLBY NR button in. To play a normal tape, push it once again.

* Dolby noise reduction manufactured under license from Dolby Laboratories Licensing Corporation. "DOLBY" and the double-D symbol  are trademarks of Dolby Laboratories Licensing Corporation.

When using a metal or chrome tape, the "METAL" light will come on.

To fast forward or rewind the tape, push the "FF (TUNE)" or "REW (TUNE)" button. To stop either fast forwarding or rewinding, push the "STOP" button. The tape will resume playing.

To change to the other side of the tape, push the "PROG (AM/FM)" button.

For quick access to the desired selection, push the "APS" button repeatedly until the figure on the display indicates how many selections ahead of/behind the one currently being played you wish to listen to (include the selection you are currently listening to when counting back previous selections). Then push the "FF (TUNE)" or "REW (TUNE)" button. The player will automatically fast forward or rewind to the beginning of the selection and play it. To cancel it, push the "STOP" button.

The maximum number of settings is nine. If the number you set exceeds the number of the selections remaining on the side currently being played, the tape will fast forward to the beginning on the other side (when fast forwarding) or rewind to the beginning on that side (when rewinding).

This function does not work properly unless the blank portions on the tape have 4 seconds or more between one selection and another.

To repeat the selection you are now listening to, push the "RPT" button while the selection is being played. The tape will automatically rewind to the beginning of the selection and play it again at the end of the selection. To cancel it, push the button once again.

To automatically skip blank portions between selections, push the "SKIP" button. The player will then automatically skip any blank portions of 6 seconds or more and play the next selection, even if it is on the other side. To cancel it, push the button once again.

To eject the cassette, push the "STOP" button.

AM-FM three-band radio with electronic tuner and cassette tape player (type A)

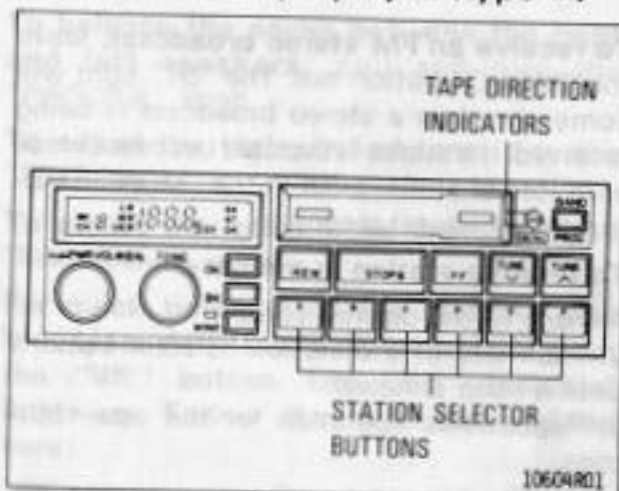

Push the "PWR.VOL" knob to turn the radio on. Then push the "BAND (PROG)" button to select either an AM long wave, AM medium wave or FM broadcast and push one of the "TUNE" buttons until a beep is heard to tune in the desired station.

Each time you push the button, one after another station is tuned in.

If the "DX" light comes on, the additional boost will assist seeking the weak broadcasts during station searching.

For manual tuning, push one of the "TUNE" buttons within 0.5 second.

To receive an FM stereo broadcast, leave the "MONO" button out. The "ST" light will come on when a stereo broadcast is being received. If a stereo broadcast becomes weak with lots of static, push in the "MONO" button for monaural reception.

To retain a station in memory:

1. Tune in the desired station.
2. Push one of the station selector buttons until a beep is heard.
3. Repeat this operation for the other buttons.

Six stations each of AM long wave, AM medium wave and FM can be retained in memory but a station can be replaced with a different one by the same procedure. The memorized station cannot be cancelled out except when the power source is severed (battery disconnected, burnt fuse, etc.)

To recall a memorized station, push one of the station selector buttons.

To adjust the volume, turn the "PWR.VOL" knob.

To balance the sound between the right and left speakers, turn the "BAL" knob.

To adjust the tone, turn the "TONE" knob.

For quick tuning-in of FM stations that broadcast ARI (traffic information) quickly, push the "BK" button until the "BK" indicator lights up and follow the next steps given here:

"SK" auto tuning—Push one of the "TUNE" buttons, and the ARI broadcast will automatically be received. The "SK" indicator lights up only when tuning in stations that broadcast ARI.

"BK" auto tuning—Push one of the station selector buttons, marked the same as the traffic area code. The indicator light comes on and the station for the desired area will automatically be tuned-in.

If the "DK" button is pushed while receiving the ARI broadcast, the indicator lights up and operates as follows:

- Only the ARI broadcast can be received while the normal broadcast is being muted.
- The alarm will sound and tune another station automatically if the station gets weaker during reception of an ARI station.
- If the radio has been set for an ARI station, the ARI broadcast will be automatically received and the tape sound will go off even if the cassette tape is playing. After the ARI broadcast is finished, the tape sound will come on again.

To turn the radio off, push the "PWR.VOL" knob once again.

To listen to a cassette tape, simply insert the cassette, with the tape side to the right, into the slot as far as it will go.

This will automatically turn on the tape player and turn off the radio. The player will automatically change directions at the end of the tape to play the other side.

When using a metal or chrome tape, the "METAL" light come on.

To fast forward or rewind the tape, push the "FF" or "REW" button. To stop either fast forwarding or rewinding, push the "STOP" button. The tape will resume playing.

To change to the other side of the tape, push the "PROG (BAND)" button.

To eject the cassette, push the "STOP" button.

AM-FM three-band radio with electronic tuner and cassette tape player (type B)

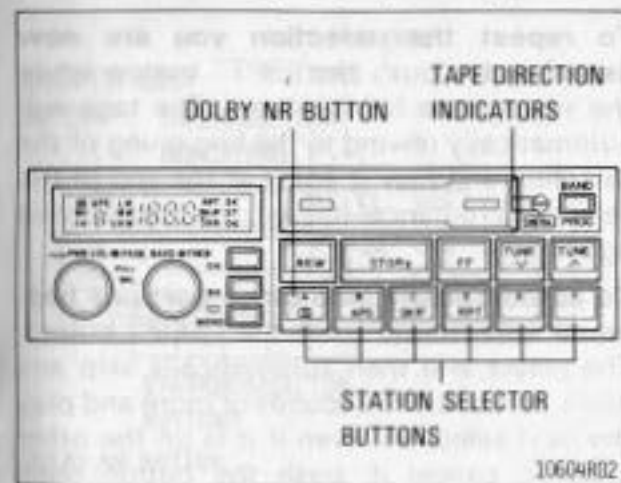

Push the "PWR.VOL" knob to turn the radio on. Then push the "BAND (PROG)" button to select either an AM long wave, AM medium wave or FM broadcast and push one of the "TUNE" buttons until a beep is heard to tune in the desired station.

Each time you push the buttons, one after another station is tuned in.

If the "DX" light comes on, the additional boost will assist seeking the weak broadcasts during station searching.

For manual tuning, push one of the "TUNE" buttons within 0.5 second.

To receive an FM stereo broadcast, leave the "MONO" button out. The "ST" light will come on when a stereo broadcast is being received. If a stereo broadcast becomes weak with lots of static, push in the "MONO" button for monaural reception.

To retain a station in memory:

1. Tune in the desired station.
2. Push one of the station selector buttons until a beep is heard.
3. Repeat this operation for the other buttons.

Six stations each of AM long wave, AM medium wave and FM can be retained in memory but a station can be replaced with a different one by the same procedure. The memorized station cannot be cancelled out except when the power source is severed (battery disconnected, burnt fuse, etc.).

To recall a memorized station, push one of the station selector buttons.

To adjust the volume, turn the "PWR.VOL" knob.

To balance the sound between the front and rear speakers, turn the "FADE" knob.

To balance the sound between the right and left speakers, pull and turn the "PWR.VOL" knob.

To adjust the high-pitched tone, turn the "TREB" knob.

To adjust the low-pitched tone, turn the "BASS" knob.

For quick tuning-in of FM stations that broadcast ARI (traffic information), push the "BK" button. The "BK" indicator lights up. Follow the next steps given here:

"SK" auto tuning—Push one of the "TUNE" buttons, and the ARI broadcast will automatically be received. The "SK" indicator lights up only when tuning in stations that broadcast ARI.

"BK" auto tuning—Push one of the station selector buttons, marked the same as the traffic area code. The indicator light comes on and the station for the desired area will automatically be tuned in.

If the "DK" button is pushed while receiving the ARI broadcast, the indicator lights up and operates as follows:

- Only the ARI broadcast can be received while the normal broadcast is being muted.

- The alarm will sound and tune another station automatically if the station gets weaker during reception of an ARI station.
- If the radio has been set for an ARI station, the ARI broadcast will be automatically received and the tape sound will go off even if the cassette tape is playing. After the ARI broadcast is finished, the tape sound will come on again.

To turn the radio off, push the "PWR VOL" knob once again.

To listen to a cassette tape, simply insert the cassette, with the tape side to the right, into the slot as far as it will go.

This will automatically turn on the tape player and turn off the radio. The player will automatically change directions at the end of the tape to play the other side.

When using a tape encoded with Dolby NR*, push the DOLBY NR button in. To play a normal tape, push it once again.

* Dolby noise reduction manufactured under license from Dolby Laboratories Licensing Corporation. "DOLBY" and the double-D symbol  are trademarks of Dolby Laboratories Licensing Corporation.

When using a metal or chrome tape, the "METAL" light will come on.

To fast forward or rewind the tape, push the "FF" or "REW" button. To stop either fast forwarding or rewinding, push the "STOP" button. The tape will resume playing.

To change to the other side of the tape, push the "PROG (BAND)" button.

For quick access to the desired selection, push the "APS" button repeatedly until the figure on the display indicates how many selections ahead of/behind the one currently being played you wish to listen to (include the selection you are currently listening to when counting back previous selections). Then push the "FF" or "REW" button. The player will automatically fast forward or rewind to the beginning of the selection and play it. To cancel it, push the "STOP" button.

The maximum number of settings is nine. If the number you set exceeds the number of the selections remaining on the side currently being played, the tape will fast forward to the beginning on the other side (when fast forwarding) or rewind to the beginning on that side (when rewinding).

This function does not work properly unless the blank portions on the tape have 4 seconds or more between one selection and another.

To repeat the selection you are now listening to, push the "RPT" button while the selection is being played. The tape will automatically rewind to the beginning of the selection and play it again at the end of the selection. To cancel it, push the button once again.

To automatically skip blank portions between selections, push the "SKIP" button. The player will then automatically skip any blank portions of 6 seconds or more and play the next selection, even if it is on the other side. To cancel it, push the button once again.

To eject the cassette, push the "STOP" button.

AM-FM radio with cassette tape player

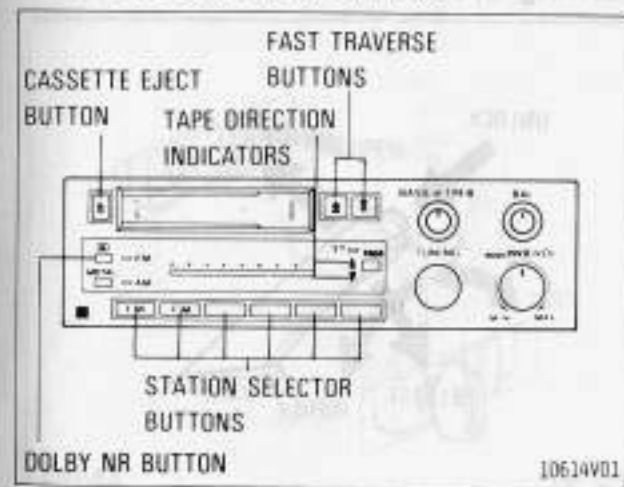

Push the "PWR.VOL" knob to turn the radio on and tune in the desired station with the "TUNING" knob. To receive FM broadcasts, push in one of the "FM" station selector buttons. To receive AM broadcasts, push in one of the unmarked buttons.

The radio will change automatically to stereo reception when an FM stereo broadcast is being received. At the same time, the "ST" light will come on. If a stereo broadcast becomes weak with lots of static, the radio will automatically switch over to monaural reception.

To set the station selector buttons:

1. Pull a button out as far as it will go.
2. Tune in the desired station.
3. Push the button in as far as it will go.
4. Repeat this operation for the other buttons.

To adjust the volume, turn the "PWR.VOL" knob.

To balance the sound between the right and left speakers, turn the "BAL" knob.

To adjust the high-pitched tone, turn the "TREB" knob.

To adjust the low-pitched tone, turn the "BASS" knob.

To turn the radio off, push the "PWR.VOL" knob once again.

To listen to a cassette tape, simply insert the cassette, with the tape side to the right, into the slot as far as it will go.

This will automatically turn on the tape player and turn off the radio. The player will automatically change directions at the end of the tape to play the other side.

When using a tape encoded with Dolby NR*, push the DOLBY NR button in. To play a normal tape, push it once again.

* Dolby noise reduction manufactured under license from Dolby Laboratories Licensing Corporation. "DOLBY" and the double-D symbol  are trademarks of Dolby Laboratories Licensing Corporation.

When using a metal or chrome tape, push the "METAL" button in. Another push will return it for a normal tape.

To fast forward or rewind the tape, first note the direction the tape is turning by the direction indicator. Then push in one of the fast traverse buttons for the direction desired. To stop either fast forwarding or rewinding, lightly push the opposite button. The tape will resume playing.

To change to the other side of the tape, push the "PROG" button.

To eject the cassette, push the cassette eject button all the way in.

Cassette tape player

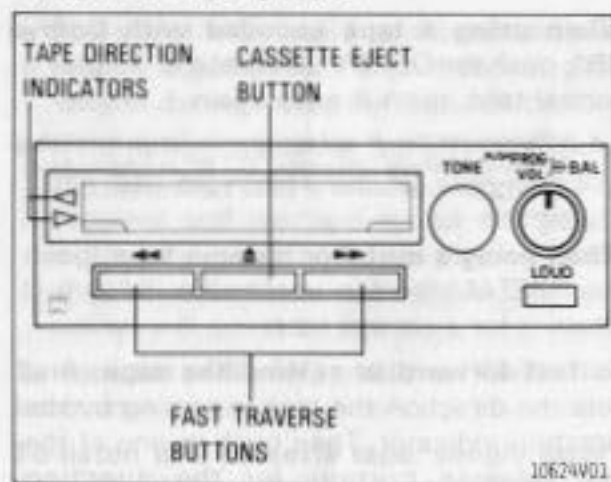

To listen to a cassette tape, simply insert the cassette into the slot as far as it will go.

This will automatically turn on the tape player and turn off the radio. The player will automatically change directions at the end of the tape to play the other side.

To fast forward or rewind the tape, first note the direction the tape is turning by the direction indicator. Then push in one of the fast traverse buttons for the direction desired. To stop fast forwarding or rewinding, lightly push the cassette eject button. The tape will resume playing.

To change to the other side of the tape, push the "PROG" button.

To eject the cassette, push the cassette eject button all the way in.

To adjust the volume, turn the "VOL" knob.

To balance the sound between the right and left speakers, turn the "BAL" knob.

To adjust the tone, turn the "TONE" knob.

To gain better sound clarity at low listening volumes, push the "LOUD" button in. This will emphasize high- and low-pitched tones to accommodate for the human ear which has a natural tendency to hear less bass and treble sounds. Another push will cancel it.

Parking brake

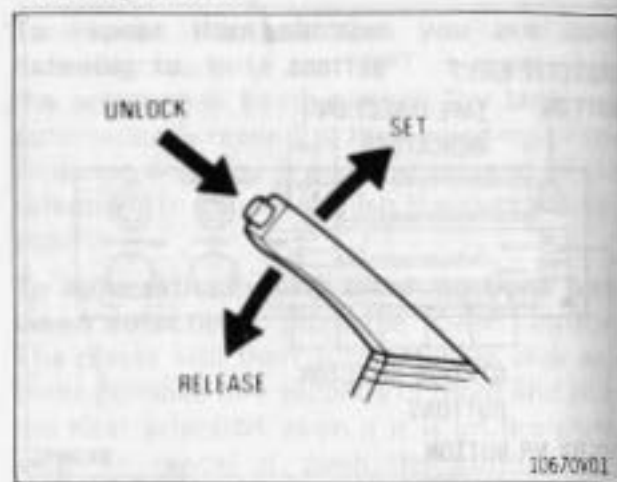

To set: Pull up the lever.

To release: Pull up slightly, press the thumb button, and lower.

Before leaving your vehicle, *firmly apply the parking brake*. For better holding power, first depress the brake pedal and hold it while setting the parking brake.

Before driving, be sure that the parking brake is fully released and the parking brake reminder light is off.

Glovebox

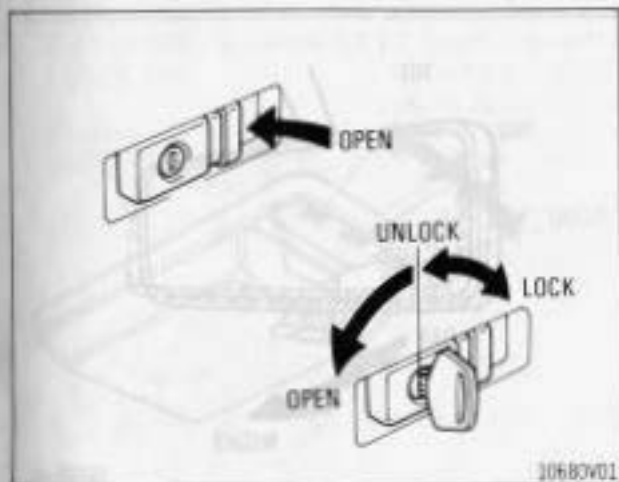

To unlock the glovebox door, insert the master key and turn it counterclockwise. To open the glovebox door, compress the button.

To reduce the chance of injury in case of an accident or a sudden stop, always keep the glovebox door closed while driving.

Power window switches

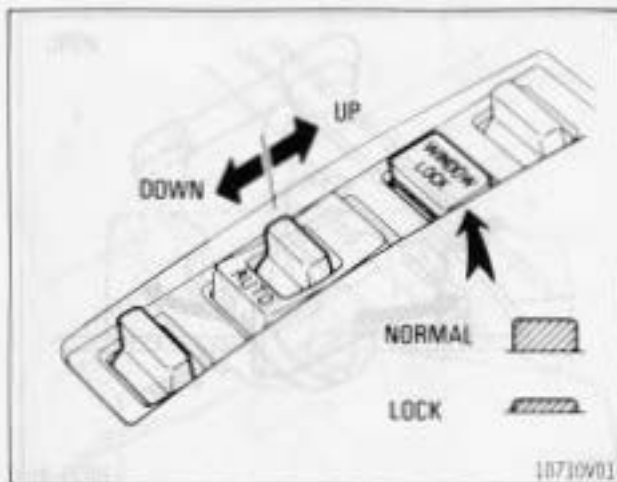

To raise or lower the windows, use the switch on each door. The windows can also be controlled by the switches on the driver's door.

When the "WINDOW LOCK" switch is pushed in, the passenger's window cannot be raised or lowered.

The ignition key must be in the "ON" position. The window glass moves as long as the switch is pushed.

To fully lower the driver's door window automatically, push in the outside switch on the "AUTO" side. To stop the window partway, lightly push the inside switch forward.

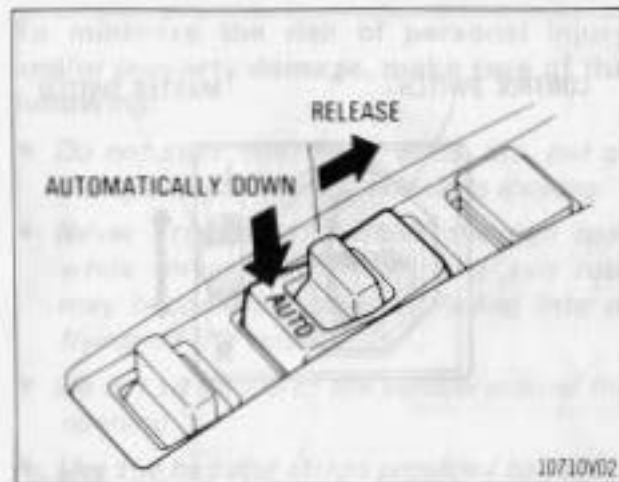

To avoid personal injury, observe the following.

- When small children are in the vehicle, take care not to allow them unexpected use of the switches. Use the "WINDOW LOCK" switch or, if you must leave them unattended, remove the key from the ignition switch.
- When closing the windows, be sure that no one has his/her head, hands or arms sticking out the window.

Power rear view mirror control

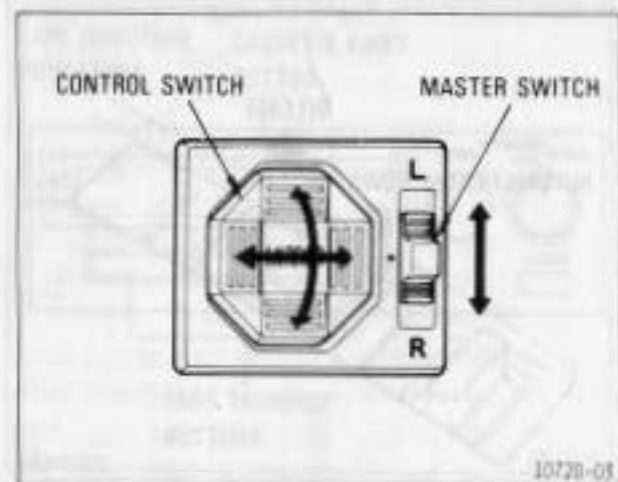

To adjust a power rear view mirror, first place the master switch at "R" (right) or "L" (left) depending on which mirror needs adjusting, then push the control switch on each direction.

If ice should jam the mirror, do not operate the control or scrape the mirror face. Use a spray de-icer to free the mirror.

Folding rear view mirrors

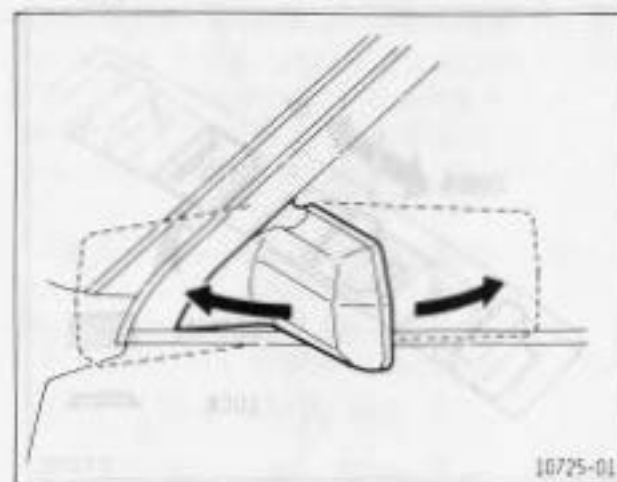

To fold the rear view mirror, push forward or backward.

The rear view mirrors can be folded forward or backward for parking in restricted areas.

Day-night rear view mirror

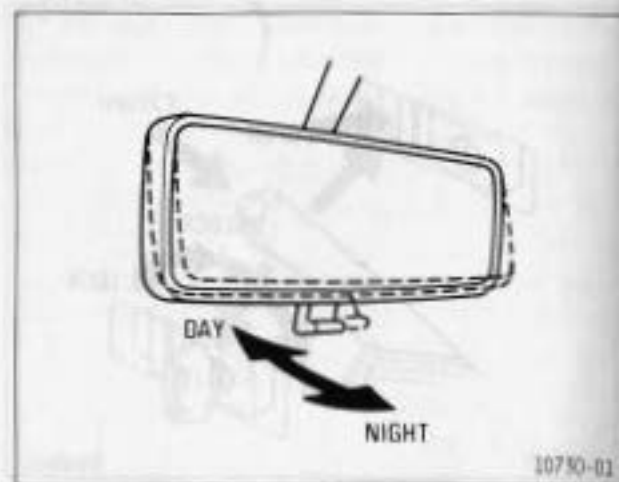

Pull the lever backward to reduce glare from the rear vehicle headlights during night driving.

Before adjusting the mirror to the position with most clarity, push the day-night change lever forward (daylight driving position).

Remember that by reducing glare you also lose some rear view clarity.

Interior light

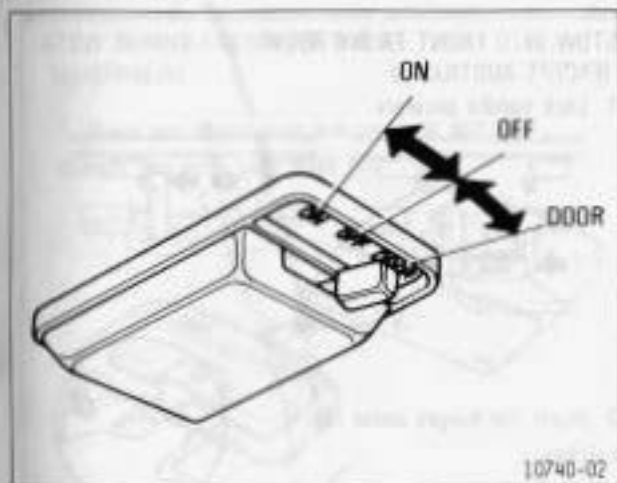

To turn on the interior light, slide the switch.

With the switch in the DOOR position, the light comes on when any of the side doors is opened.

Detachable sun shade

Detachable sun roof

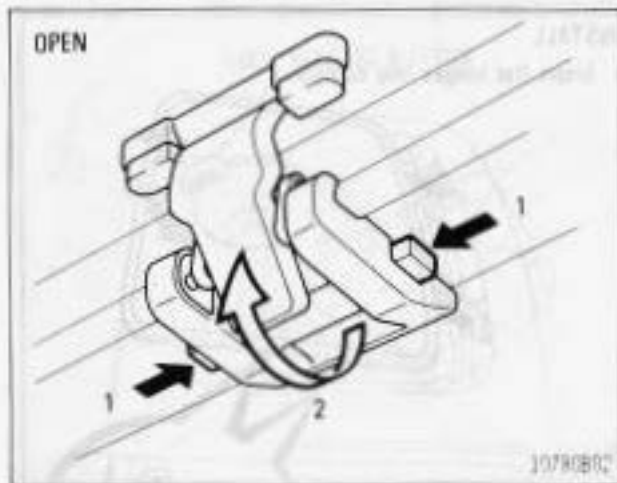

To open the sun roof, first pull down on the handle while pushing in one of the lock buttons. Then push up the sun roof until it locks.

After opening the sun roof, make sure the handle is secure in place.

The sun roof and sun shade may be removed and stowed in the front trunk room. On vehicles sold in Australia, they are put into the storage bag and secured behind the passenger's seat using the straps provided.

T-bar roof

Removing the glass roofs

To minimize the risk of personal injury and/or property damage, make sure of the following:

- Do not stick your head, arms, etc. out of the opening while the vehicle is moving.
- Never attempt to remove the sun roof while driving. Otherwise, the sun roof may become a hazard by falling into or flying off the vehicle.
- Do not sit on top of the vehicle around the opening.
- Use the bag and straps provided to secure the sun roof and sun shade (Australia). Use them to secure only the sun roof and sun shade.
- Secure the sun roof and sun shade in the front trunk room using the fixing device provided (except Australia).
- Do not operate the vehicle without being certain that the sun roof is securely locked in place.
- When installing, be sure to use your palm to push up the handle.

REMOVE

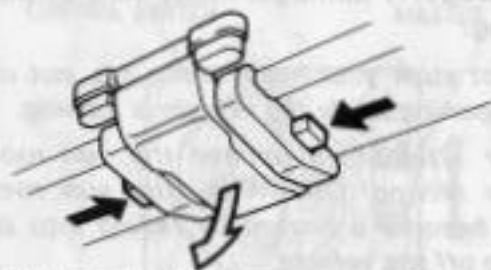

1. Pull down handle while pushing in lock button.

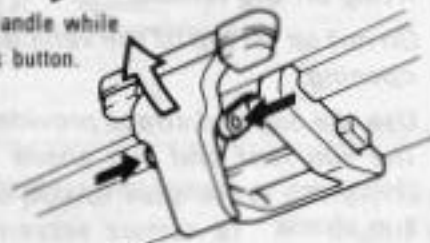

2. Push in retaining spring arms and push up sun roof.

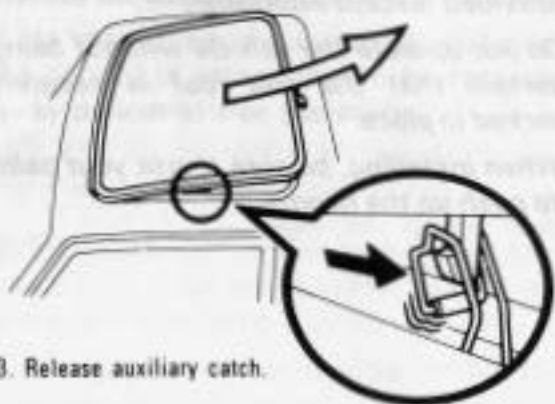

3. Release auxiliary catch.

1078CB01

INSTALL

1. Insert flat hinges into cutouts.

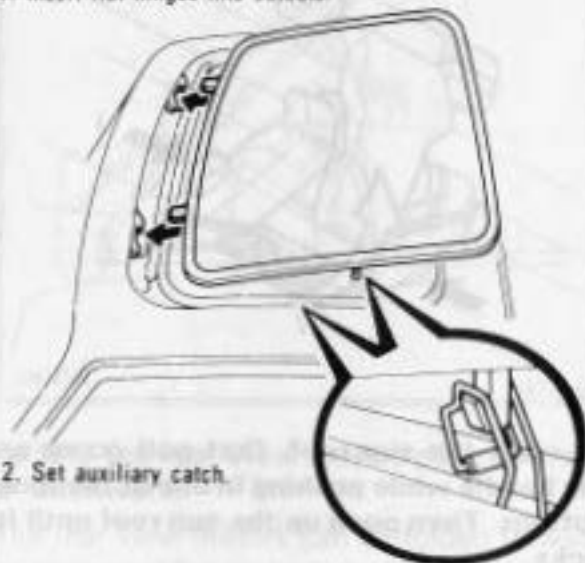

2. Set auxiliary catch.

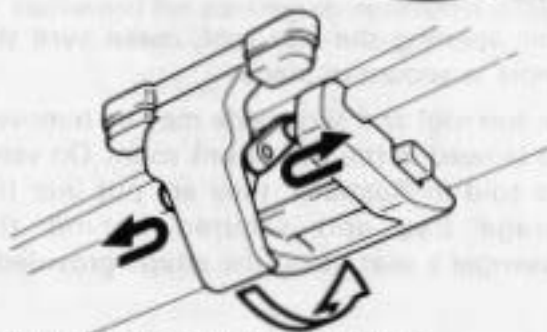

3. Press in and insert retaining spring arms and push up handle with your palm. Then, check to see if it is locked by pulling down handle.

1078CB05

STOW INTO FRONT TRUNK ROOM (EXCEPT AUSTRALIA)

1. Lock handle securely.

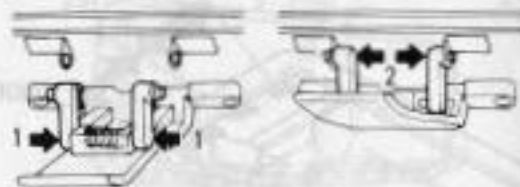

2. Insert flat hinges under rear catches.

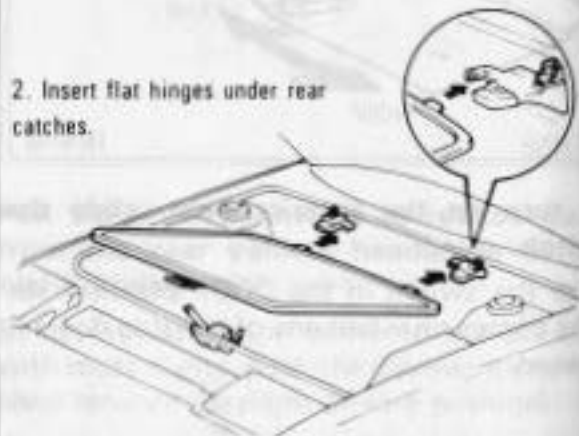

3. Place handle on front catch and lock it securely with levers.

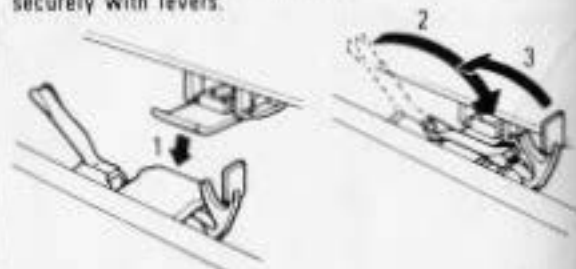

1078BV51

**STOW BEHIND PASSENGER'S SEAT
(AUSTRALIA)**

1. Place sun shade over sun roof and put into storage bag with oval edge first.



2. Place storage bag behind passenger's seat with caution label side facing engine compartment.
3. Secure storage bag with straps.

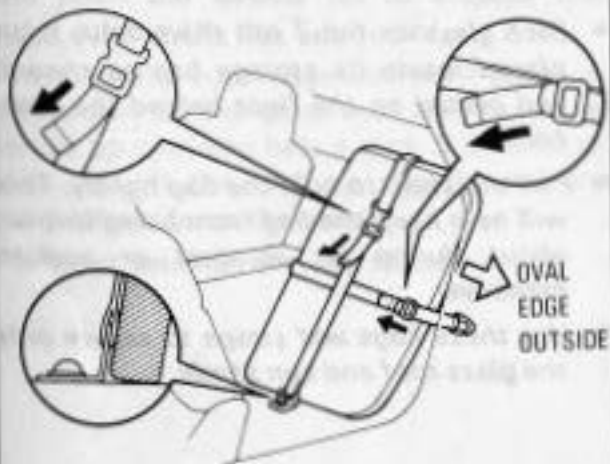

10780V02

**Detachable sun shade
(for sun roof)**

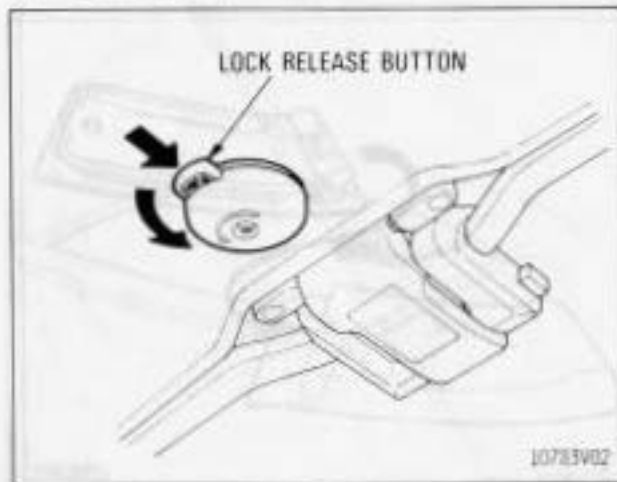

To remove the sun shade, first turn the knob counterclockwise while pushing in the lock release button. And then pull it out rearward.

To install it, insert the two flat hinges into the cutouts provided. Then turn the knob counterclockwise while pushing in the lock release button.

For safety, do not remove the sun shade while driving.

**T-bar roof—
Removing the glass roofs**

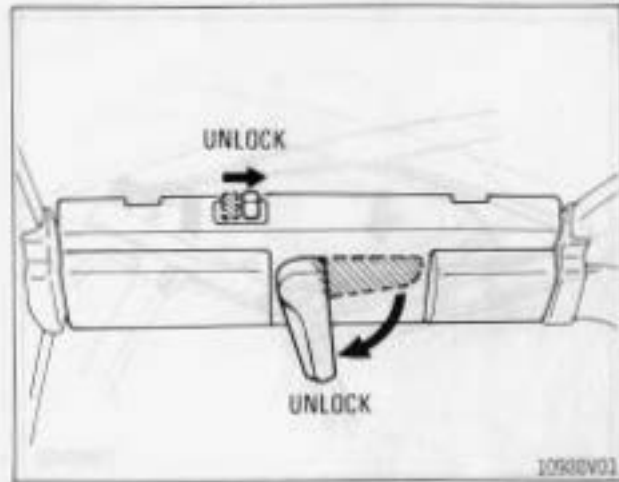

Remove the sun shades. Then push the lock release knob forward and pull the handle toward you.

To make removal easier, open the door.

Take care not to damage the glass roof surface.

Never attempt to remove the glass roof while driving. Otherwise, the glass roof may become a hazard by falling into or flying off the vehicle.

When driving with the roof off, keep your head and arms inside the vehicle.

Do not sit on top of the vehicle around the T-bar roof.

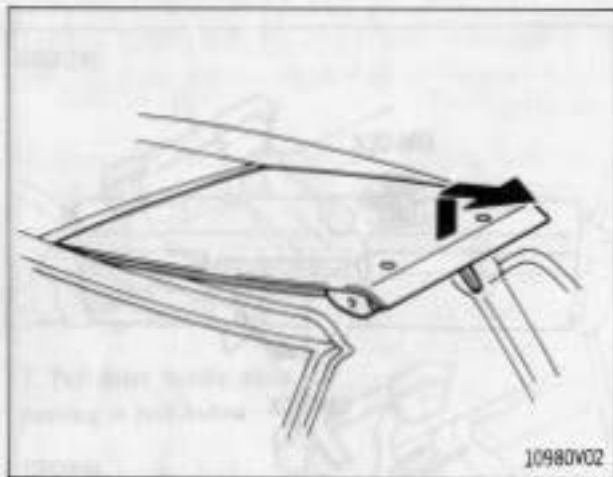

Raise the outer edge of the glass roof and pull toward you to release it from the center roof bar.

To minimize the risk of personal injury, do not operate the vehicle without being certain that each glass roof is securely locked in the roof or held behind the seats in its stowage bags.

Stowing behind the seats

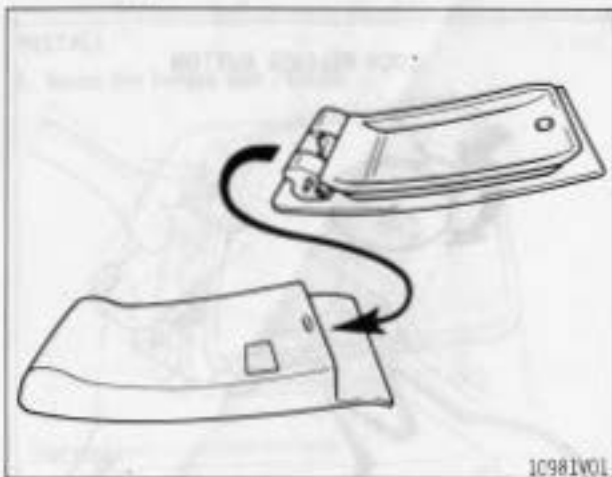

Place the sun shade over the glass roof and put both into the storage bag. Secure the storage bag with the straps.

The storage bags and straps are provided behind the seats.

Before placing the sun shade and the glass roof in the bag, return the handle to the lock position. This prevents possible damage to the handle while you are driving.

When placing the sun shade over the glass, be sure that the tabs are inserted in the installation holes in the glass roof.

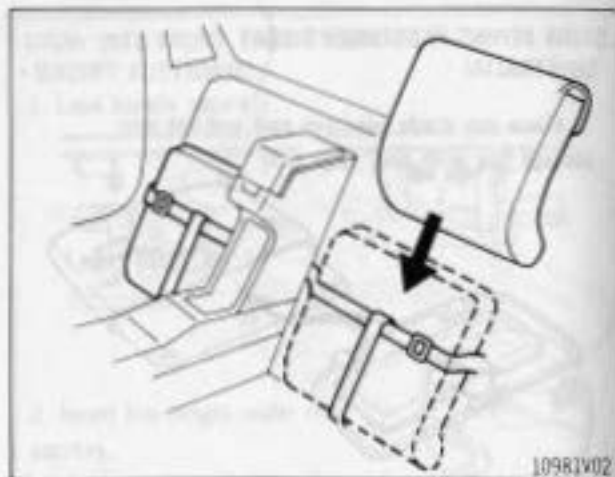

To minimize the risk of personal injury and/or property damage, make sure of the following:

- *Each glass roof and sun shade have been placed inside its storage bag as shown, and placed on the floor behind the seat-back.*
- *Pull the strap to hold the bag tightly. This will help keep the bag from being thrown about during an accident or sudden maneuver.*
- *Use these bags and straps to secure only the glass roof and sun shade.*

Installing the glass roofs

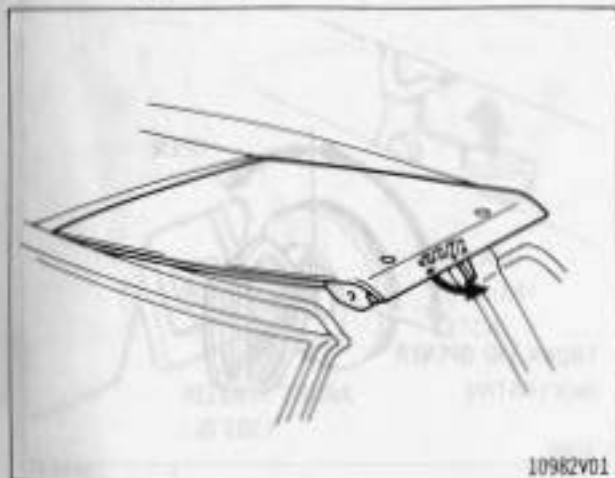

Pull the handle out. Insert the inner edge of the glass roof into the center roof bar and push the handle up to engage the outer edge with the T-bar roof.

To engage the outer edge with the T-bar roof, hold down on the glass roof and push the handle up until you hear a click. If difficult to push up, lift the roof up slightly and try again. **Never force the handle.**

If desired, reinstall the sun shade.

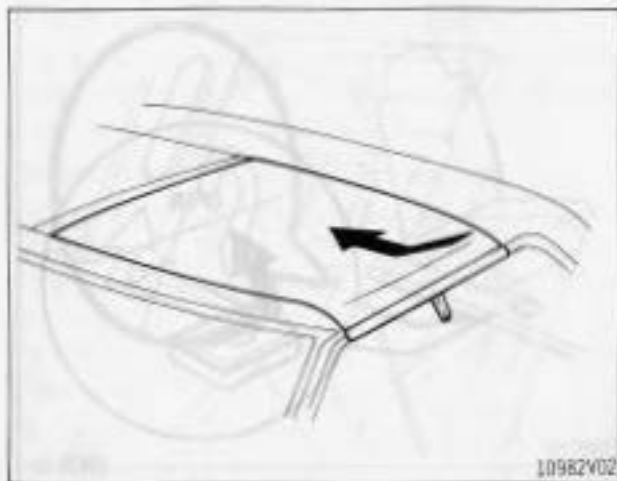

Insert the glass roof into the center roof bar upward at an angle and then push in.

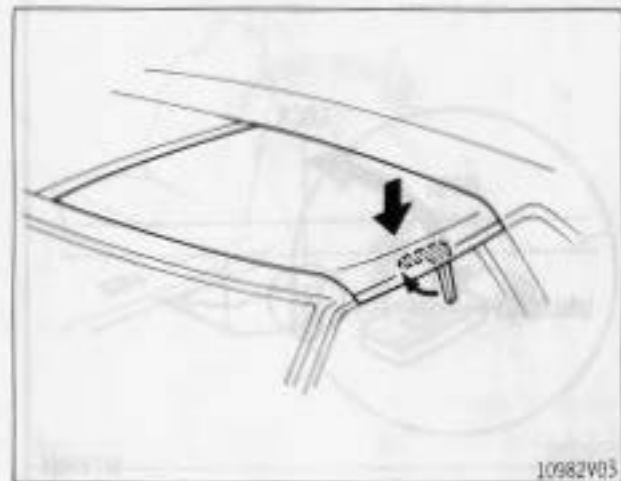

Pushing in on the center of the glass roof, push the handle to the lock position.

After installing the glass roofs, make sure they are firmly secured by pushing up on the underside of each roof.

Detachable sun shade (for T-bar roof)

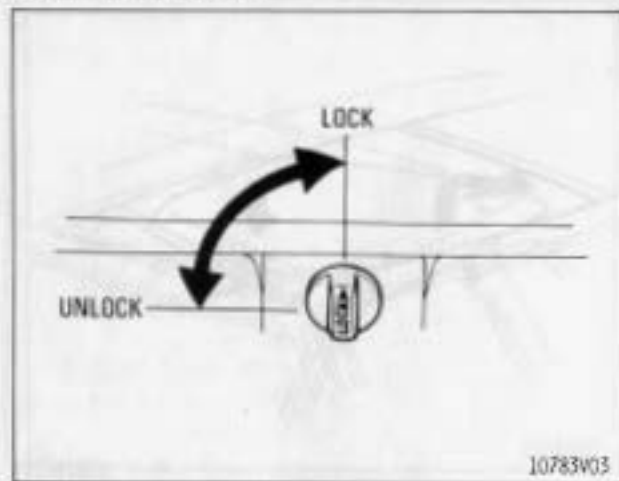

To remove: Turn the knob counterclockwise and pull down the sun shade.

To install: Insert the two flat hinges into the cutouts provided. Then turn the knob clockwise to lock the sun shade.

For safety, do not remove the sun shade while driving.

Rear trunk lid opener

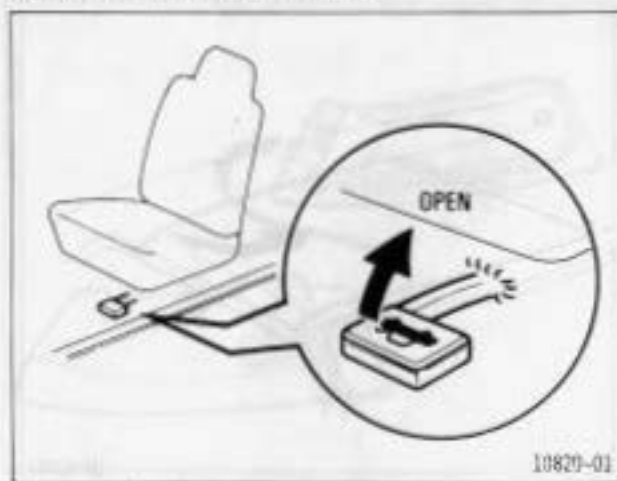

To open the rear trunk lid while sitting in the driver's seat, pull the lever up.

The trunk lid opener system will be cancelled by turning the key in the trunk lock counterclockwise. To protect things locked in the trunk, always use this feature when you have your vehicle parked.

Rear trunk lid

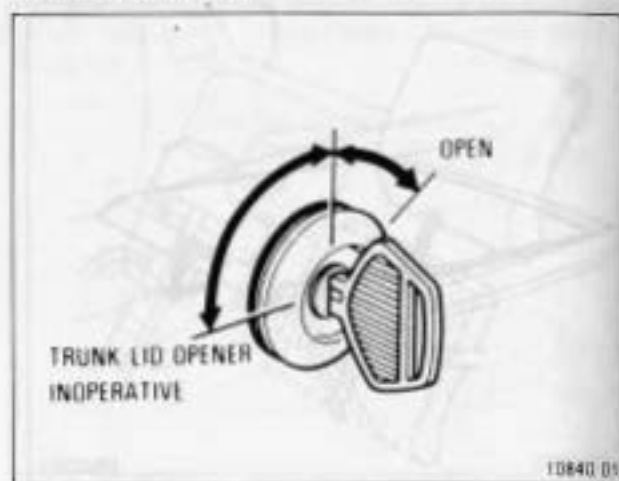

To open the rear trunk lid, insert the master key and turn it clockwise.

To close the trunk lid, lower and press down on it. *After closing the trunk lid, try pulling it up to make sure it is securely closed.*

If you turn the key fully counterclockwise after closing the trunk lid, the trunk lid opener will not work. To protect things locked in the trunk, always use this feature when you have your vehicle parked.

Front trunk lid

boot



To open the front trunk lid, pull the lock release lever under the dash and the trunk lid will spring up slightly. In front of the vehicle, press up on the auxiliary catch lever and lift the trunk lid.

An important warning about the engine exhaust

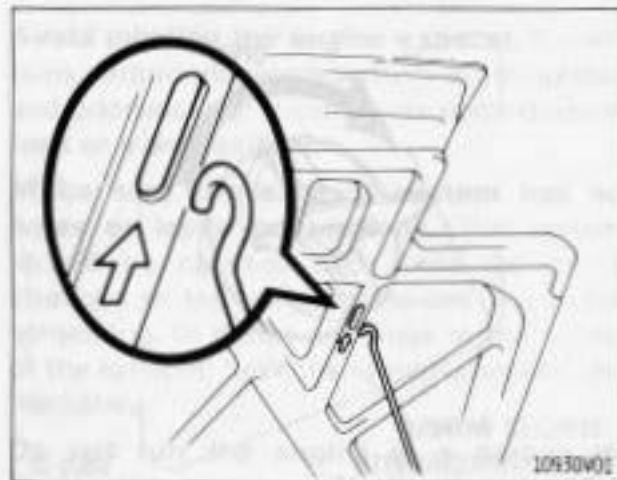

After lifting the trunk lid up, hold it open by inserting the support rod into the slot.

The end of the rod should be inserted into the slot. *Make sure the rod supports the trunk lid securely.*

Before closing the trunk lid, return the support rod to its clip—this prevents rattles. Then lower the trunk lid and make sure it locks into place. If necessary, press down gently on the front edge to lock it.

If you smell exhaust fumes in the vehicle, drive with the windows open. Have the engine immediately serviced and inspected.

Fuel filler door opener and fuel tank cap

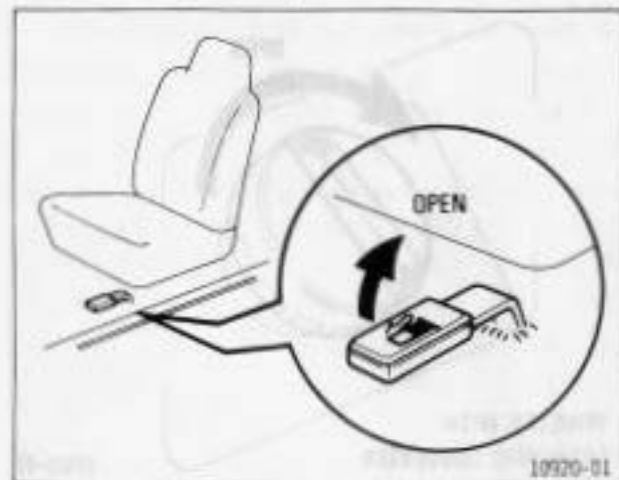

1. To open the fuel filler door, pull the lever up.

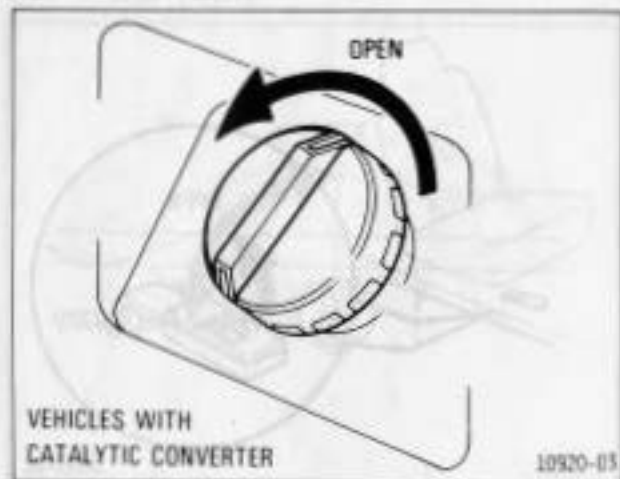

2. To remove the fuel tank cap, turn the cap slowly counterclockwise, then pause slightly before removing it.

Do not remove the cap quickly. Fuel may be under pressure and spray out of the fuel filler neck under hot weather conditions, etc., which may cause injury. It is not unusual to hear a slight swoosh when the cap is opened.

To install the cap, turn the cap clockwise till you hear a click on vehicles with a catalytic converter. On vehicles without a catalytic converter, make sure the tabs in the cap are properly aligned with the cutouts in the tank opening.

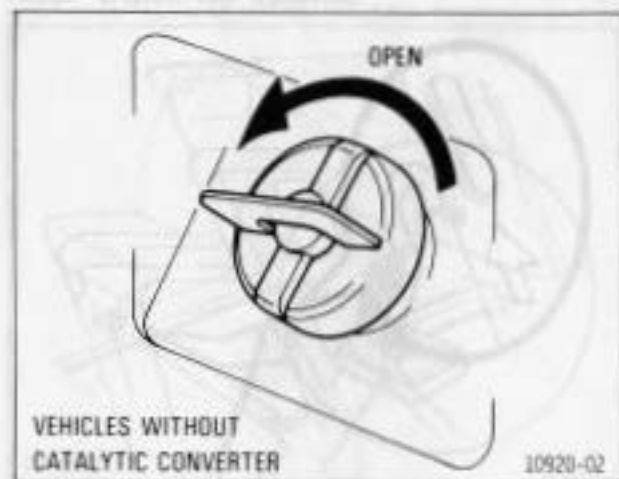

Make sure that the cap is tightened securely to prevent fuel spillage in case of an accident.

Use only a genuine Toyota fuel tank cap for replacement. It has a built-in check valve.

Hood

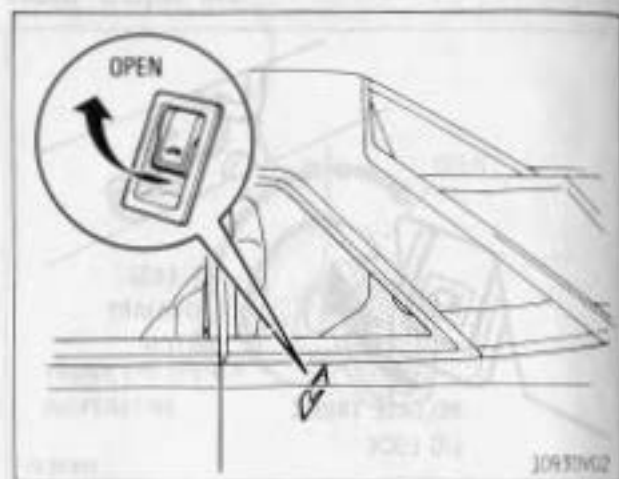

To open the hood, pull the lock release lever behind the driver's seat. The hood will spring up slightly. Lift the hood.

Before starting the engine

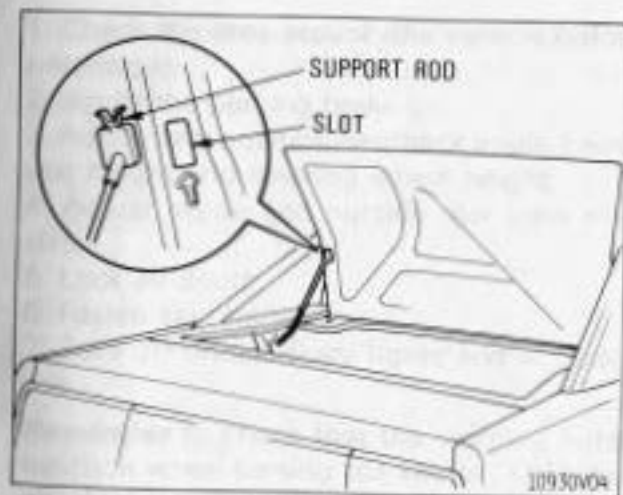

After lifting the hood up, hold it open by inserting the support rod into the slot.

The end of the rod should be inserted into the slot. *Make sure the rod supports the hood securely.*

Before closing the hood, check to see that you have not forgotten any tools, rags, etc. and return the support rod to the original position—this prevents rattles. Then lower the hood and make sure it locks into place. If necessary, press down gently on the rear edge to lock it.

An important warning about the engine exhaust

Avoid inhaling the engine exhaust. It contains carbon monoxide, which is a colorless and odorless gas. It can cause unconsciousness or even death.

Make sure the exhaust system has no holes or loose connections. The system should be checked each time the oil is changed or the vehicle is raised. If you hit something, or notice a change in the sound of the exhaust, have the system checked immediately.

Do not run the engine in a garage or enclosed area except for the time needed to drive the vehicle in or out. The exhaust gases cannot escape, making this a particularly dangerous situation.

Do not remain for a long time in a parked vehicle with the engine running. If it is unavoidable, however, do so only in an unconfined area and adjust the heating or cooling system to force outside air into the vehicle.

To allow proper operation of your vehicle's ventilation system, keep the inlet grilles in front of the windshield clear of snow, leaves, or other obstructions.

If you smell exhaust fumes in the vehicle, drive with the windows open. Have the cause immediately located and corrected.

If the engine will not start, it may be flooded...

1. Turn the ignition key to the "off" position and wait 10 to 15 seconds.

2. Turn the ignition key to the "on" position and wait 10 to 15 seconds. Then turn the key to the "start" position and try to start the engine.

3. If the engine still will not start, stop trying to start it. Have the engine checked by a qualified mechanic.

4. If the engine starts, drive the vehicle to a safe place and stop. Have the engine checked by a qualified mechanic.

5. If the engine starts, drive the vehicle to a safe place and stop. Have the engine checked by a qualified mechanic.

6. If the engine starts, drive the vehicle to a safe place and stop. Have the engine checked by a qualified mechanic.

7. If the engine starts, drive the vehicle to a safe place and stop. Have the engine checked by a qualified mechanic.

8. If the engine starts, drive the vehicle to a safe place and stop. Have the engine checked by a qualified mechanic.

9. If the engine starts, drive the vehicle to a safe place and stop. Have the engine checked by a qualified mechanic.

10. If the engine starts, drive the vehicle to a safe place and stop. Have the engine checked by a qualified mechanic.

11. If the engine starts, drive the vehicle to a safe place and stop. Have the engine checked by a qualified mechanic.

Before starting the engine

1. Check the area around the vehicle before entering it.
2. Apply the parking brake.
3. Adjust seat position, seatback angle, headrest height and steering wheel height.
4. Adjust inside and outside rear view mirrors.
5. Lock all doors.
6. Fasten seat belts.
7. Turn off unnecessary lights and accessories.

Remember to check that the warning lights function when turning the key to "ON", and check the fuel gauge to see that you have sufficient fuel.

How to start the engine

Normal starting procedure

The electronic fuel injection system in your engine automatically controls the proper air-fuel mixture for starting. So you can start the cold or hot engine as follows.

1. **Press the clutch pedal to the floor and shift the transmission into neutral.** Hold the clutch pedal to the floor until the engine is started.
2. **With your foot off the accelerator pedal,** crank the engine by turning the key to "START". Release it when the engine starts. Do not crank for more than 15 seconds at a time if the engine does not start immediately.
3. After the engine warms up for about 10 seconds, you are ready to drive. **Do not race a cold engine.**

If the weather is below freezing, let it warm up for a few minutes before driving. **Do not leave the vehicle while the engine is warming up.**

If the engine will not start, it may be flooded...

- Depress the accelerator pedal and hold it to the floor.
- **While holding the accelerator pedal to the floor,** crank the engine. It may take about 15 seconds of continuous cranking to clear the excess fuel.
- After cranking, **release the accelerator pedal** and crank the engine until it starts.

Driving with a manual transmission

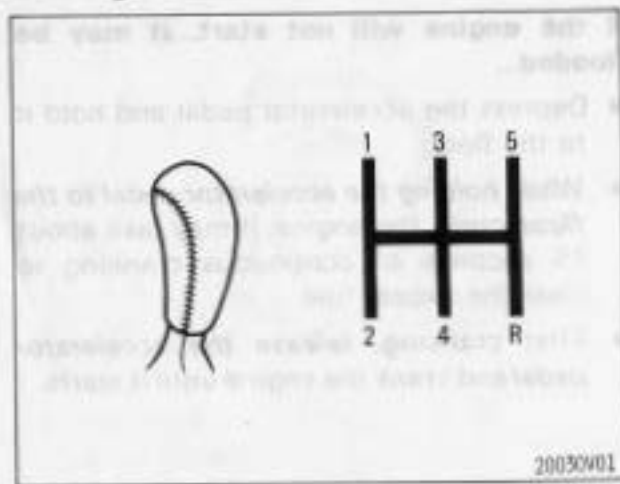

The shift pattern is conventional as shown above.

Use the clutch correctly.

Press the pedal down fully while shifting, and then release it slowly. Do not rest your foot on the pedal while driving, because it will cause needless wear. And do not slightly release the clutch to hold the vehicle when stopped on an uphill grade — use the parking brake.

Recommended shifting speeds

- For good fuel economy and long engine life, you should upshift at the following speeds:

gear	approx. speed km/h (mph)
1 to 2	24 (15)
2 to 3	40 (25)
3 to 4	65 (40)
4 to 5	72 (45)

Shifting too soon will cause lugging and, possibly, pinging. Regularly revving the engine to maximum speed in each gear will cause excessive engine wear and high fuel consumption. Make sure the vehicle is completely stopped before shifting into reverse.

- If you slow to less than the following speeds, such as when cornering, downshift to the next lower gear

gear	km/h (mph)
2	20 (12)
3	33 (21)
4	40 (25)
5	50 (31)

The transmission is fully synchronized and downshifting is easy.

Good driving practice

- When driving down a long hill, reduce your speed and downshift to a lower gear. The engine will provide a braking effect. Remember, if you ride the brakes, they may overheat and not work properly.

- Avoid overrevving the engine by slowing down before downshifting — especially on wet, icy, or snow covered roads — because it could cause a loss of traction.
- Always slow down in gusty crosswinds. Slowing down will allow you much better control.
- Make sure the vehicle is completely stopped before shifting into reverse. If it is difficult to shift into reverse, put the transmission in neutral, release the clutch pedal momentarily, and then try again.
- Be careful when accelerating, upshifting, downshifting or braking on a slippery surface. The abrupt change in engine speed, such as sudden acceleration or engine braking, could cause the vehicle to spin or skid.
- To get on a highway or to pass slower traffic, maximum acceleration may be necessary. Make sure you observe the following maximum allowable speeds in each gear:

gear	km/h (mph)
1	59 (37)
2	98 (61)
3	143 (89)
4	193 (120)

Do not downshift if you are going faster than the maximum allowable speed for the next lower gear.

Driving with the cruise control

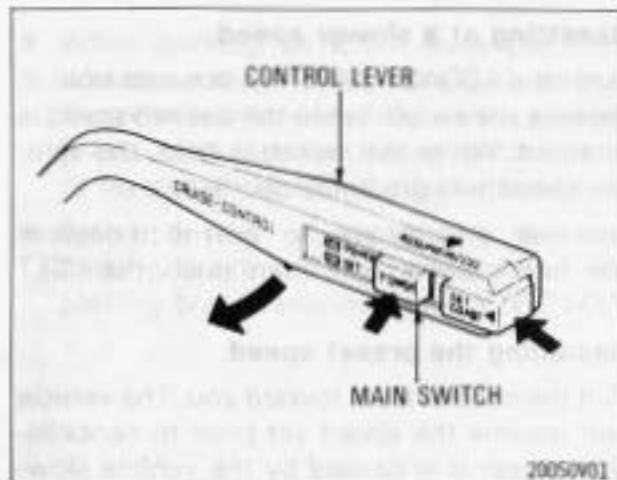

The cruise control allows you to cruise the vehicle at a desired speed over 40 km/h (25 mph) even with your foot off the accelerator pedal.

Your cruising speed can be maintained up or down grades within the limits of engine performance, although a slight speed change may occur when driving up or down the grades. On steeper hills, a greater speed change will occur so it is better to drive without the cruise control.

Do not use the cruise control when driving in heavy or varying traffic, or on slippery (rainy, icy or snow-covered) or winding roads.

Main switch and indicator lights

To operate the cruise control, push the main switch ("POWER" switch). This turns the system on and the "POWER" light will come on. The indicator light "SET" shows that you can now set the vehicle at a desired cruising speed. Another push will turn the system completely off.

Keep the main switch off when not using the cruise control.

Setting at a desired speed

Bring the vehicle to a desired speed, push the "SET (COAST)" switch and release it. This sets the vehicle at that speed. Now you may take your foot off the accelerator pedal. If you need acceleration—for example, when passing—depress the accelerator pedal enough for the vehicle to exceed the set speed. When you release it, the vehicle will return to the speed set prior to the acceleration.

Cancelling the preset speed

You can cancel the preset speed by:

- depressing the brake pedal;
- depressing the clutch pedal.

If the vehicle speed falls below 40 km/h (25 mph), the preset speed will automatically cancel out.

If the vehicle speed drops 16 km/h (10 mph) below the preset speed, the preset speed will also automatically cancel out.

If the preset speed automatically cancels out except for the above cases or if the main switch indicator light flashes several times, the cruise control may malfunction. In such cases, have your vehicle checked by your Toyota dealer at the earliest opportunity.

CAUTION: While driving with the cruise control on, *do not shift to neutral without depressing the clutch pedal*, as this may cause engine racing or overrevving. If this happens, either depress the clutch pedal or push the main switch off immediately.

Resetting at a faster speed

Pull the control lever toward you and hold it. Release the lever when the desired speed is attained. While the lever is held, the vehicle will gradually gain speed.

However, a faster way to reset is to accelerate the vehicle and then push the "SET (COAST)" switch.

Resetting at a slower speed

Push the "COAST (SET)" switch and hold it. Release the switch when the desired speed is attained. While the switch is held, the vehicle speed will gradually decrease.

However, a faster way to reset is to depress the brake pedal and then push the "SET (COAST)" switch.

Resuming the preset speed

Pull the control lever toward you. The vehicle will resume the speed set prior to cancellation unless it is caused by the vehicle slowing down to less than 40 km/h (25 mph) or to a speed 16 km/h (10 mph) below the preset speed.

Braking tips

Driving with the Toyota tandem master cylinder brake system. The Toyota tandem master cylinder brake system is a hydraulic system with two separate sub-systems. If either sub-system should fail, the other will still work. However, the pedal will be harder to press, and your stopping distance will be longer. Also, the brake system warning light may come on. *Do not rely on a single brake system. Have your brakes fixed immediately.*

Driving with the brake booster. The brake booster uses engine vacuum to power-assist the brakes. If the engine should quit while you are driving, you can bring the vehicle to a stop with normal pedal pressure. There is enough reserve vacuum for one or two stops — but no more!

Do not pump the brake pedal if the engine stalls. Each push on the pedal uses up your vacuum reserve.

Even if the power assist is completely lost, the brakes will still work. But you will have to push the pedal hard — much harder than normal. And your braking distance will be longer.

Pre-drive safety check

Good braking practice

- Washing your vehicle or driving through deep water may get the brakes wet. If they are wet, your vehicle will require a longer stopping distance, and it may pull to one side when the brakes are applied. To see whether they are wet, check for no traffic near you, and then press the pedal lightly. If you do not feel a normal braking force, the brakes are probably wet. To dry them, drive the vehicle cautiously while lightly pressing the brake pedal. If they still do not work safely, pull to the side of the road and call a Toyota dealer for assistance.
- To drive down a long or steep hill, reduce your speed and downshift. Remember, if you ride the brakes excessively, they may overheat and not work properly.
- Do not rest your foot on the brake pedal while driving. It can cause dangerous overheating, needless wear, and poor fuel economy.
- If you have a flat tire while driving, do not brake suddenly. Keep a straight line while reducing speed. Then slowly move completely off the road to a safe place.

- When parking on a hill, turn the front wheels until they touch the curb so that the vehicle will not roll. Apply the parking brake, and place the transmission in first or reverse. If necessary, block the wheels.
- Before driving off, make sure that the parking brake is fully released and the parking brake reminder light is off.

Wet and flooded road driving tips

Large amounts of water entering the engine compartment may cause damage to the engine and/or electrical components.

You should avoid driving through large amounts of standing water on the road.

How to save fuel and make your vehicle last longer, too

Getting more kilometers/mileage from a liter/gallon of fuel is easy—just take it easy. It will help make your vehicle last longer, too. Here are some specific tips on how to save money on both fuel and repairs:

- **Keep your tires inflated at the correct pressure.** Check the pressure at least once a month. Under-inflation causes tire wear and wastes fuel.
- **Do not carry unneeded weight in your vehicle.** Excess weight puts a heavier load on the engine, causing greater fuel consumption.
- **Avoid lengthy warm-up idling.** Once the engine is running smoothly, begin driving—but gently. Remember, however, that in cold winter days this may take a little longer.
- **Accelerate slowly and smoothly.** Avoid jackrabbit starts. Get into high gear as quickly as possible.
- **Avoid long engine idling.** If you have a long wait and you are not in traffic, it is better to turn off the engine and start again later.
- **Avoid engine lug or overrevving.** Use a gear range suitable for the road you are travelling on.

- **Use your air conditioner only when absolutely necessary.** The air conditioner puts an extra load on the engine.
- **Avoid continuous speeding up and slowing down.** Stop-and-go driving wastes fuel.
- **Avoid unnecessary stopping and braking.** Maintain a steady pace. Try to time the traffic signals so you only need to stop as little as possible or take advantage of through streets to avoid traffic lights. Keep a proper distance from other vehicles to avoid sudden braking. This will also reduce wear on your brakes.
- **Avoid heavy traffic or traffic jams whenever possible.**
- **Do not rest your foot on the clutch or brake pedal.** This causes needless wear, overheating and poor fuel economy.
- **Maintain a moderate speed on highways.** The faster you drive, the greater the fuel consumption. By reducing your speed, you will cut down on fuel consumption.
- **Keep the front wheels in proper alignment.** Avoid hitting the curb and slow down on rough roads. Improper alignment not only causes faster tire wear but also puts an extra load on the engine, which, in turn, wastes fuel.

Beating Tips

- **Keep the bottom of your vehicle free from mud, etc.** This not only lessens weight but also helps prevent corrosion.
- **Keep your vehicle tuned-up and in top shape.** A dirty air cleaner, improper valve clearance, dirty plugs, dirty oil and grease, brakes not adjusted, etc. all lower engine performance and contribute to poor fuel economy. For longer life of all parts and lower operating costs, keep all maintenance work on schedule, and if you often drive under severe conditions, see that your vehicle receives more frequent maintenance (See Section 5).

NOTE: Never turn off the engine to coast down hills. Your brake booster will not function without the engine running. Instead, downshift to an appropriate gear to utilize engine braking effect.

Pretrip safety check

It is a good idea to review the safety check before starting out on a trip. A few minutes of checking can help ensure safe and pleasant driving. Just a basic familiarity with your vehicle is required and a careful eye! Or, if you would like, your Toyota dealer will be pleased to make this check for you at a nominal cost.

If you make this check in an enclosed garage, make sure there is adequate ventilation. **Engine exhaust is poisonous.** (See carbon monoxide warning in Section 1.)

BEFORE STARTING THE ENGINE

Outside the vehicle

Tires. Check the pressure with a gauge and look carefully for cuts, damage, or excessive wear.

Wheel nuts. Make sure no nuts are missing or loose.

Fluid leaks. After the vehicle has been parked for a while, check underneath for leaking fuel, oil, water, or fluid. (Water dripping from the air conditioner after use is normal.)

Windshield wiper blades. Look for wear or cracks.

Lights. Make sure that the headlights, stop lights, tail lights, turn signals and other lights are all working. Check the headlight aim.

Inside the cabin

Seat belts. Check that the buckles lock securely. Make sure that the belts are not worn or frayed.

Horn. Does it work?

Instruments and controls. Especially make sure that the warning lights, instrument lights, and defroster are working.

Wipers and washer. Make sure that they both work and that the wipers do not streak.

Brakes. Make sure that the pedal has enough clearance. (See Section 6 for instructions.)

Spare fuses. Make sure you have spare fuses. They should cover all the amperage ratings designated on the fuse box lid.

In the engine compartment

Coolant level. Make sure that the coolant level is correct. (See Section 6 for instructions.)

Cooling system hoses. Check the hoses for cracks, kinks, rot, and loose connections.

Battery and cables. All the battery cells should be filled to the proper level with distilled water. Look for corroded or loose terminals and a cracked case. Check the cables for good condition and connections.

Wiring. Look for damaged, loose, or disconnected wires.

Engine drive belts. Check all belts for fraying, cracks, wear or oiliness. Apply thumb pressure between the pulleys. The deflection of each belt should be within the specified limits. (See Section 6 for instructions.)

Fuel lines. Check the lines for leaks or loose connections.

Inside the front trunk

Spare tire and jack. Check the tire pressure and make sure you have your jack and wheel nut wrench.

Radiator and hoses. Make sure the front of the radiator is clean—not blocked with leaves, dirt, or bugs. Check the hoses for cracks, kinks, rot, and loose connections.

Brake and clutch fluid levels. Make sure that the brake and clutch fluid levels are correct. (See Section 6 for instructions.)

AFTER STARTING THE ENGINE

Exhaust system. Look for cracks, holes and loose supports. Listen for any leakage. Have any leaks fixed immediately. (See carbon monoxide warning in Section 1.)

Engine oil level. Stop the engine and check the dipstick with the vehicle parked on a level spot. (See Section 6 for instructions.)

How to save fuel and make your vehicle last longer, too

WHILE DRIVING

Instruments. Make sure that the speedometer and gauges are working.

Brakes. At a safe place make sure the brakes do not pull.

Anything unusual? Look for loose parts and leaks. Listen for abnormal noises.

If everything looks O.K., set your mind at ease and enjoy your trip!

Does your vehicle need repairing?

Be on the alert for changes in performance, sounds, and visual tip-offs that indicate service is needed. Some important clues are as follows:

- Engine missing, stumbling, or pinging
- Appreciable loss of power
- Strange engine noises
- A leak under the vehicle (however, water dripping from the air conditioner after use is normal.)
- Change in exhaust sound (This may indicate a dangerous carbon monoxide leak. Drive with the windows open and have the exhaust system checked immediately.)
- Flat-looking tire; excessive tire squeal when cornering; uneven tire wear
- Vehicle pulls to one side when driving straight on a level road
- Strange noises related to suspension movement
- Loss of brake effectiveness; spongy feeling brake or clutch pedal; pedal almost touches floor; vehicles pull to one side when braking
- Engine temperature continually higher than normal

- Engine continually runs hot; oil pressure gauge stays low

If you notice any of these clues, take your vehicle to your Toyota dealer as soon as possible. It probably needs adjustment or repair.

If your vehicle will not start—

Winter driving tips



Make sure you have antifreeze in the radiator.

There are two types of antifreeze in common use: ethylene-glycol and alcohol.

The ethylene-glycol type is the antifreeze your new Toyota is delivered with and the type your dealer will always use. In addition to preventing freezing and subsequent damage to the engine block, this type will prevent corrosion and lubricate the water pump.

The alcohol type is the antifreeze for use only in winter season. If this type is to be used, remember to flush the cooling system completely when winter is over and refill with clean water.

Check the condition of the battery and cables.

Cold temperatures reduce the capacity of any battery, so it must be in top shape to provide enough power for winter starting. Section 6 tells you how to visually inspect the battery. Your Toyota dealer and most service stations will be pleased to check the level of charge.

Make sure the engine oil viscosity is suitable for the cold weather.

See Section 6 for recommended viscosity. Leaving a heavy summer oil in your vehicle during winter months may cause harder starting. If you are not sure about which oil to use, call your Toyota dealer—he will be pleased to help.

Check the spark plugs and ignition system.

Make sure the plugs are not worn, fouled, or incorrectly gapped. Section 6 has instructions for inspecting. (Note that this is not necessary for platinum-tipped spark plugs.) Visually check the rest of the system for loose connections or obvious damage.

Keep the door locks from freezing.

Squirt lock de-icer or glycerine into the locks to keep them from freezing. To open a frozen lock, try heating the key before inserting it.

Push starting

Use windshield washer fluid containing an antifreeze solution.

This product is available at your Toyota dealer and most auto parts stores. Follow the manufacturer's directions for how much to mix with water. Do not use engine antifreeze or any other substitute because it may damage your vehicle's paint.

Do not use your parking brake when there is a possibility it could freeze.

When parking, put the transmission into first or reverse and temporarily apply the parking brake. Then, block the rear wheels. After being absolutely sure that the vehicle will not move, release the parking brake.

Keep the headlights raised when there is a possibility they could freeze.

Keep ice and snow from accumulating under the fenders.

Ice and snow built up under your fenders can make steering difficult. During bad winter driving, stop and check under the fenders occasionally.

Depending on where you are driving, we recommend you carry some emergency equipment.

Some of the things you might put in the vehicle are tire chains, window scraper, bag of sand or salt, flares, small shovel, jumper cables, etc.

other etc.
 Some of the things you might not expect to find in the trunk window screen bag of the car include: first aid kit, spare tire, tools, etc.

Remember, you can't see through the rear window screen bag when you're driving. So if you're carrying anything in there, you'll have to make sure it's secure and won't fall out or get damaged.

Don't drink and drive. If you're drinking, don't drive. It's a simple rule, but one that's often broken. Drinking and driving is a dangerous combination. It's not just about the alcohol in your system, but also about the judgment impairment that comes with it. So if you're going to drink, make sure you have a designated driver or a taxi home.

Keep the headlights turned on when there is a possibility they could freeze.
 Keep the wipers and snow from accumulating under the hood.

Be sure to check the battery level before you start driving. A dead battery can be a real problem, especially in winter when the car's electrical system is under a lot of stress. So if you're going to drive in the snow, make sure your battery is in good shape.

Keep the headlights turned on when there is a possibility they could freeze.
 Keep the wipers and snow from accumulating under the hood.

Be sure to check the battery level before you start driving. A dead battery can be a real problem, especially in winter when the car's electrical system is under a lot of stress. So if you're going to drive in the snow, make sure your battery is in good shape.

Keep the headlights turned on when there is a possibility they could freeze.
 Keep the wipers and snow from accumulating under the hood.

Be sure to check the battery level before you start driving. A dead battery can be a real problem, especially in winter when the car's electrical system is under a lot of stress. So if you're going to drive in the snow, make sure your battery is in good shape.

Keep the headlights turned on when there is a possibility they could freeze.
 Keep the wipers and snow from accumulating under the hood.

Be sure to check the battery level before you start driving. A dead battery can be a real problem, especially in winter when the car's electrical system is under a lot of stress. So if you're going to drive in the snow, make sure your battery is in good shape.

Keep the headlights turned on when there is a possibility they could freeze.
 Keep the wipers and snow from accumulating under the hood.

Be sure to check the battery level before you start driving. A dead battery can be a real problem, especially in winter when the car's electrical system is under a lot of stress. So if you're going to drive in the snow, make sure your battery is in good shape.

Keep the headlights turned on when there is a possibility they could freeze.
 Keep the wipers and snow from accumulating under the hood.

Be sure to check the battery level before you start driving. A dead battery can be a real problem, especially in winter when the car's electrical system is under a lot of stress. So if you're going to drive in the snow, make sure your battery is in good shape.

Keep the headlights turned on when there is a possibility they could freeze.
 Keep the wipers and snow from accumulating under the hood.

Be sure to check the battery level before you start driving. A dead battery can be a real problem, especially in winter when the car's electrical system is under a lot of stress. So if you're going to drive in the snow, make sure your battery is in good shape.

Keep the headlights turned on when there is a possibility they could freeze.
 Keep the wipers and snow from accumulating under the hood.

Be sure to check the battery level before you start driving. A dead battery can be a real problem, especially in winter when the car's electrical system is under a lot of stress. So if you're going to drive in the snow, make sure your battery is in good shape.

Keep the headlights turned on when there is a possibility they could freeze.
 Keep the wipers and snow from accumulating under the hood.

Be sure to check the battery level before you start driving. A dead battery can be a real problem, especially in winter when the car's electrical system is under a lot of stress. So if you're going to drive in the snow, make sure your battery is in good shape.

Keep the headlights turned on when there is a possibility they could freeze.
 Keep the wipers and snow from accumulating under the hood.

Be sure to check the battery level before you start driving. A dead battery can be a real problem, especially in winter when the car's electrical system is under a lot of stress. So if you're going to drive in the snow, make sure your battery is in good shape.

Keep the headlights turned on when there is a possibility they could freeze.
 Keep the wipers and snow from accumulating under the hood.

Be sure to check the battery level before you start driving. A dead battery can be a real problem, especially in winter when the car's electrical system is under a lot of stress. So if you're going to drive in the snow, make sure your battery is in good shape.

Keep the headlights turned on when there is a possibility they could freeze.
 Keep the wipers and snow from accumulating under the hood.

Be sure to check the battery level before you start driving. A dead battery can be a real problem, especially in winter when the car's electrical system is under a lot of stress. So if you're going to drive in the snow, make sure your battery is in good shape.

Keep the headlights turned on when there is a possibility they could freeze.
 Keep the wipers and snow from accumulating under the hood.

Be sure to check the battery level before you start driving. A dead battery can be a real problem, especially in winter when the car's electrical system is under a lot of stress. So if you're going to drive in the snow, make sure your battery is in good shape.

Keep the headlights turned on when there is a possibility they could freeze.
 Keep the wipers and snow from accumulating under the hood.

Be sure to check the battery level before you start driving. A dead battery can be a real problem, especially in winter when the car's electrical system is under a lot of stress. So if you're going to drive in the snow, make sure your battery is in good shape.



Winter driving tips

In case of an emergency—Section 3

If your vehicle will not start— Simple checks

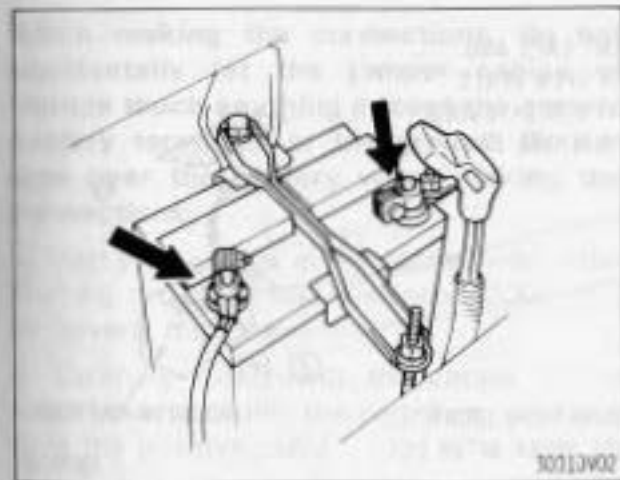

If the engine is not turning over or is turning over too slowly—

1. Check that the battery terminals are tight and clean.
2. Switch on the interior light. If it is out, dim, or goes out when the starter is cranked, the battery is discharged.

Vehicles without catalytic converter: You may try jump starting or push starting.

Vehicles with catalytic converter: You may try jump starting, but do not pull- or push-start the vehicle. The catalytic converter may overheat and become a fire hazard.

If your vehicle overstarts

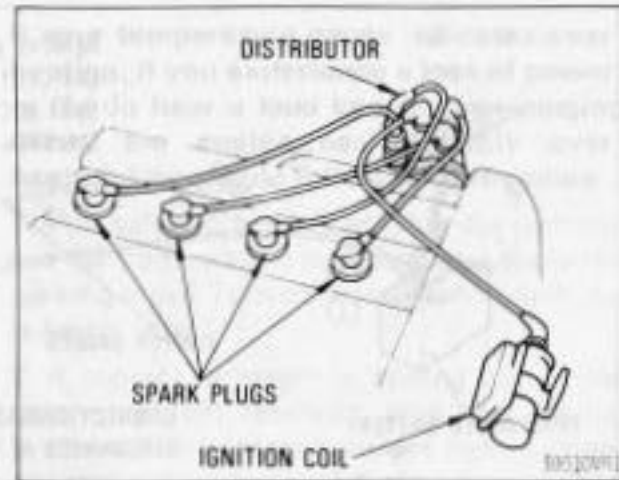

If the engine turns over at its normal speed but will not start—

1. Check the fuel gauge.
2. Check that all the push-on connectors are tight at the coil, distributor, and spark plugs.
3. If the engine is warm or if you smell raw gasoline, the engine may be flooded—see the starting instructions.

Vehicles without catalytic converter only: If it still will not start, remove and dry the spark plugs. Crank the engine for about 20 seconds, and reinstall the plugs.

4. If the engine still will not start, it needs adjustment or repair. Call a Toyota dealer or qualified repair shop for assistance.

Push starting

Do not push start a vehicle with a catalytic converter.

1. Make sure the bumpers of the push vehicle and your vehicle match for a solid push. **Mismatched bumper height may lead to one bumper overriding the other, causing damage or an accident.**

2. Turn the ignition key to "ON", and shift into second gear.

3. Hold in the clutch and let the push vehicle slowly accelerate your vehicle to about 15 km/h (10 mph). **Be aware that the brakes will be much harder to press when the engine is not running.**

4. At 15 km/h (10 mph), hold the accelerator about halfway down, and slowly release the clutch to start the engine.

5. As the engine starts, signal the push-vehicle driver to stop and at the same time accelerate away from the push vehicle to avoid a collision.

Never tow a vehicle to start it. When the engine starts, the vehicle may jump forward and hit the vehicle towing it.

Jump starting

To avoid serious personal injury and damage to your vehicle which might result from battery explosion, acid burns, electrical burns, or damaged electronic components, these instructions must be followed precisely. If you are unsure about how to follow this procedure, we strongly recommend that you seek the help of a competent mechanic or towing service.

WARNING: Batteries contain sulfuric acid, which is poisonous and corrosive. Wear protective safety glasses when jump starting, and avoid spilling acid on your skin, clothing, or vehicle. If you should accidentally get acid on yourself or in your eyes, *remove any contaminated clothing and flush the affected area with water for at least 15 minutes.* Then get **immediate** medical attention. If possible, continue to apply water with a sponge or cloth while enroute to the medical office.

The gas normally produced by a battery will explode if a flame or spark is brought near. Therefore, do not smoke or light a match while jump starting.

The battery used for boosting must be 12-volt. Do not jump start unless you are sure that the booster battery is correct.

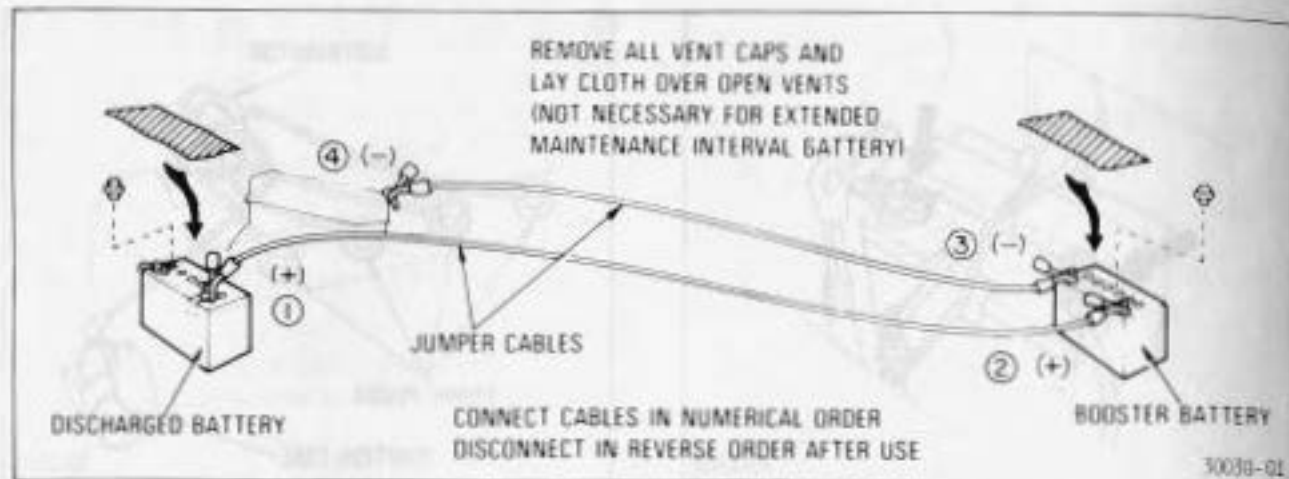

1. If the booster battery is installed in another vehicle, make sure that the vehicles are not touching. Turn off all unnecessary lights and accessories.

2. Remove all the vent caps from the booster and the discharged batteries. Lay a cloth over the open vents on both batteries. (This helps reduce the explosion hazard.)

NOTE: If your Toyota is equipped with an extended maintenance interval battery, it is not necessary to remove the filler caps. (If you are unsure about whether you have an extended maintenance interval battery, see "Checking battery condition and fluid level" in Section 6.)

3. If the engine in the vehicle with the booster battery is not running, start it and let it run for a few minutes. During jumping run the engine at about 2000 rpm.

4. Connect the jumper cables in the exact order shown in the illustration *positive-to-positive(+)*, and *negative-to-engine or body ground(-)*. Note that you first connect the positive cable to the discharged battery and then to the booster battery. Next, connect the negative cable to the booster battery and then to a solid, stationary, metallic point (e.g. engine hanging hook) away from the battery. Do not connect it to or near any part that moves when the engine is cranked.

When making the connections, do not accidentally let the jumper cables or clamps touch anything except the correct battery terminals or the ground. Do not lean over the battery when making the connections.

5. Start your engine in the normal way. After starting, run it at a fast idle speed (2000 rpm) for several minutes.

6. Carefully disconnect the cables in the exact **reverse** order: the negative cable and then the positive cable.

7. Carefully dispose of the battery cover cloths—they may now contain sulfuric acid.

8. Replace all the battery vent caps.

If the cause of your battery discharging is not apparent (for example, lights left on), you should have it checked.

If your vehicle overheats

If your temperature gauge indicates overheating, if you experience a loss of power, or if you hear a loud knocking or pinging noise, the engine has probably overheated. You should follow this procedure...

1. Pull safely off the road, stop the vehicle, put the transmission in neutral and apply the parking brake. Turn off the air conditioner if it is being used.

2. If coolant or steam is boiling out of the engine coolant reservoir, stop the engine. Wait until the steam subsides before opening the engine hood. If there is no coolant boiling over or steam, leave the engine running and make sure that the radiator cooling fan is operating. If it is not, turn the ignition off.

3. **Visually** check to see if the engine drive belt (water pump belt) is broken or loose. Look for obvious coolant leaks from the radiator, hoses, and under the vehicle. However, note that water draining from the air conditioner is normal if it has been used.

When the engine is running, keep hands and clothing away from the moving fan and engine drive belts.

4. If the engine drive belt is broken or the coolant is leaking, stop the engine immediately. Call a Toyota dealer for assistance.

5. If the engine drive belt is O.K. and there are no obvious leaks, check the coolant reservoir. If it is dry, add water to the reservoir while the engine is running. Fill it about half full.

WARNING: Do not attempt to remove the engine coolant filler cap when the engine is hot. Serious injury could result from scalding hot fluid and steam blown out under pressure.

6. After the engine temperature has cooled to normal, again check the coolant level in the reservoir. If necessary, bring it up to half full again. Serious coolant loss indicates a leak in the system. You should have it checked as soon as possible at your Toyota dealer.

If a retractable headlight does not operate

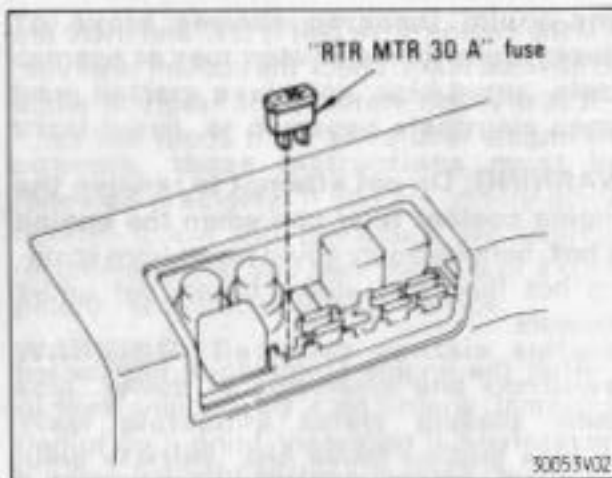

Turn the ignition and headlight switches off and pull out the "RTR MTR 30 A" fuse.

Unless power is disconnected, there is danger of the headlights suddenly retracting or extending and causing injury.

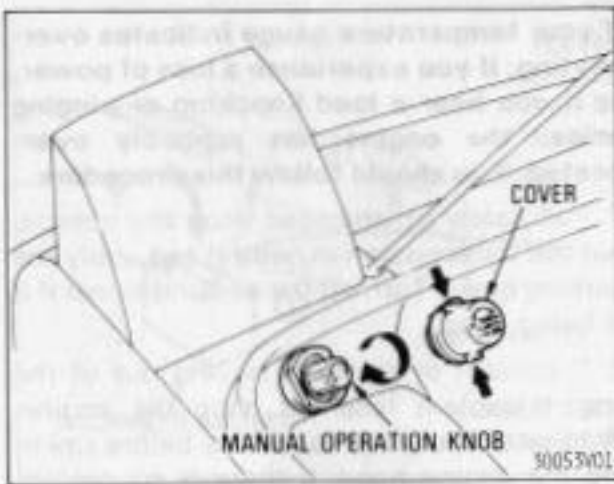

To raise or lower an inoperative headlight, remove the cover from the manual operation knob next to the inoperative headlight, and turn the knob clockwise.

After the headlights are extended, turn on the light switch and check to see that the lights come on.

When the headlights are retracted, they should match the silhouette of the vehicle body.

Be sure to have the system checked by your Toyota dealer as soon as possible.

If you have a flat tire —

First, make sure you are completely off the road — well away from the traffic. Avoid stopping on the center divider of a highway. Park on a level spot with firm ground.

Second, stop the engine and turn on your emergency flashers.

Third, firmly set the parking brake and put the transmission in reverse.

Fourth, have everyone get out of the vehicle on the side away from traffic.

Fifth, read the following instructions thoroughly. They are designed to help a person who has never before changed a tire.

Jacking precautions

To reduce the possibility of personal injury:

- Follow jacking instructions.
- Use a jack only for lifting your vehicle during wheel changing.
- Never get beneath the vehicle when supported by a jack.
- Do not start or run the engine while your vehicle is supported by a jack.

Spare tire precautions



If your vehicle is equipped with a compact spare tire (The compact spare tire is identified by the distinctive wording "TEMPORARY USE ONLY" molded into the side wall of the tire.), keep the following in mind.

- The compact spare tire is designed for temporary emergency use only. The standard tire should be repaired and replaced as soon as possible.
- On snow covered or freezing roads, do not use the compact spare tire on the rear wheel. If you have a rear flat tire, mount the compact spare tire on the front wheel and mount the removed front tire on the rear wheel.

Removing wheel ornament

- Do not use a tire chain on the compact spare tire.
- Do not use two compact spare tires at the same time.
- Do not exceed 80 km/h (50 mph) when driving with the compact spare tire.
- Drive slowly on rough, unpaved roads, or over speed bumps as the high air pressure of the compact spare tire may cause severe shocks, resulting in deformation of the wheel disc.
- Your ground clearance is reduced when the compact spare tire is installed so avoid driving over obstacles. Also, do not attempt to go through an automatic car wash as the vehicle may get caught, resulting in damage.

NOTE: Check the air pressure of your compact spare tire at least once a month, and maintain the pressure at 4.2 kg/cm^2 (60 psi, 410 kPa). When adding air to the compact spare tire you must be very careful, since the smaller tire size can gain pressure very quickly. Add compressed air in small quantities and check the pressure often until it reaches 4.2 kg/cm^2 (60 psi, 410 kPa). (See Section 7 for additional information on the compact spare tire.)

Required tools and spare tire

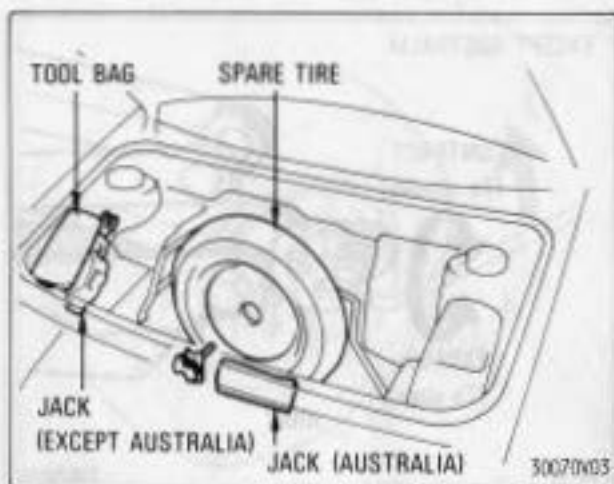

1. Get the tool bag, jack and spare tire.

To prepare yourself for an emergency, you should familiarize yourself with the use of the jack, each of the tools and their storage locations.

If a retractable headlight
downward and back up

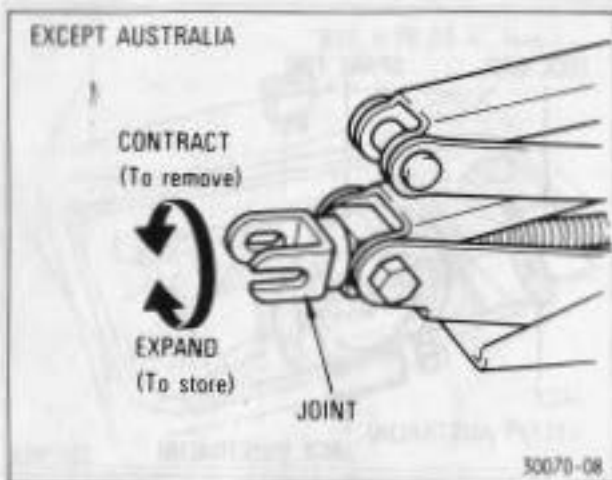

When removing the jack, turn the joint by hand towards the CONTRACT direction until the jack is free. When storing, turn the joint by hand towards the EXPAND direction until the jack is firmly secured to prevent it from flying forward during a collision or sudden braking.

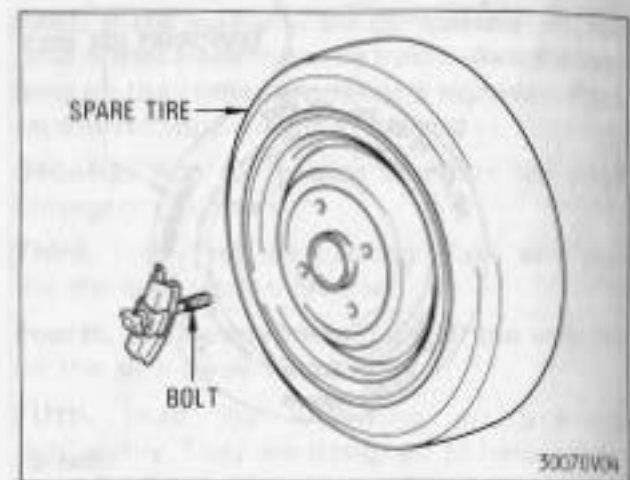
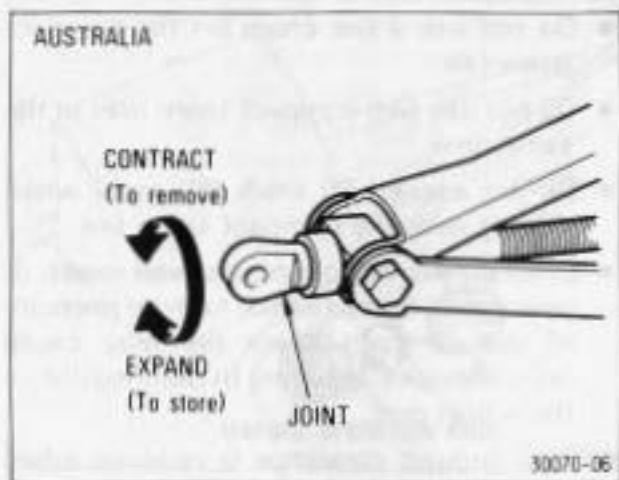

To remove the spare tire, loosen the bolt and remove it.

When storing the spare tire, see "After changing wheels" in this section.

Blocking the wheel

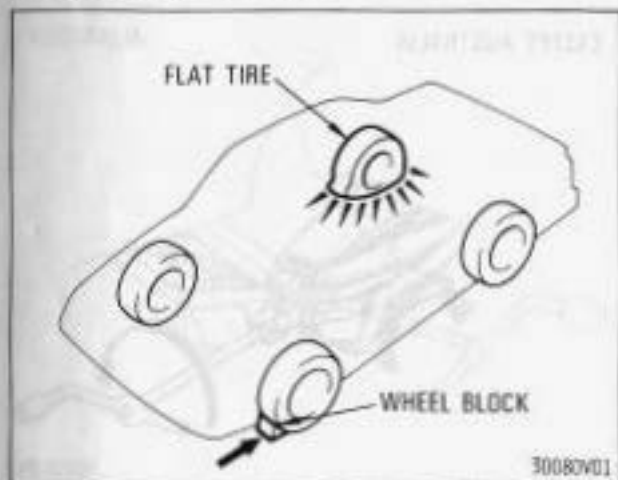

2. Block the wheel diagonally opposite the flat tire to keep the vehicle from rolling when it is jacked up.

When blocking the wheel, place the wheel block from the front for the front wheels or from the rear for the rear wheels.

Removing wheel ornament

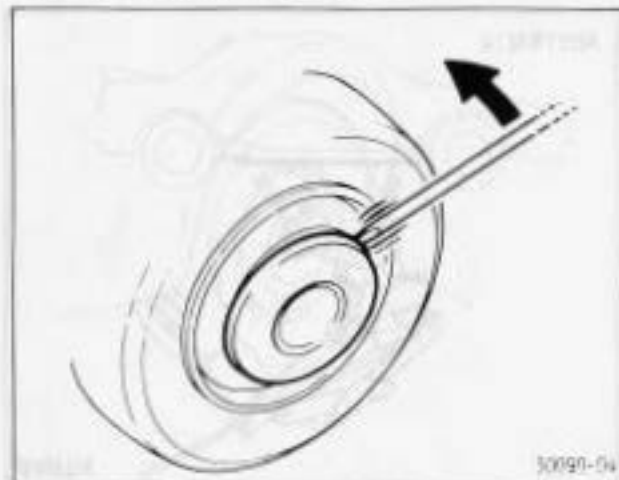

3. Remove the wheel ornament.

Pry off the wheel ornament, using the beveled end of the spark plug wrench handle as shown. *To avoid personal injury, do not attempt to pull off the ornament by hand.*

Loosening wheel nuts

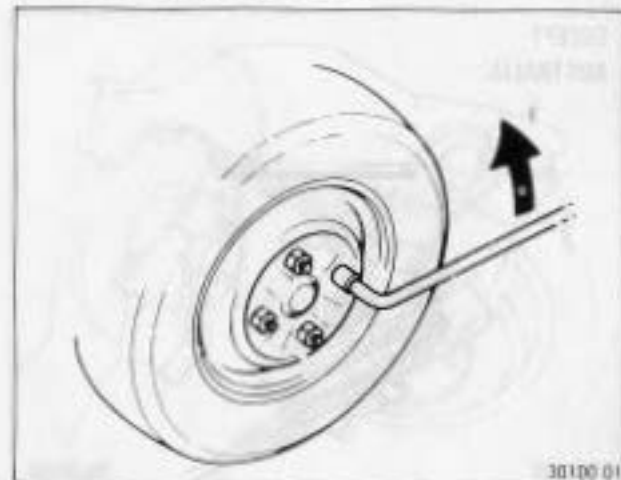

4. Loosen all the wheel nuts.

Always loosen the wheel nuts *before* raising the vehicle.

The nuts turn *counterclockwise* to loosen. To get maximum leverage, fit the wrench to the nut so that the handle is on the right side, as shown above. Grab the wrench near the end of the handle and pull up on the handle. Be careful that the wrench does not slip off the nut.

Do not remove the nuts yet—just unscrew them about one-half turn.

Positioning the jack

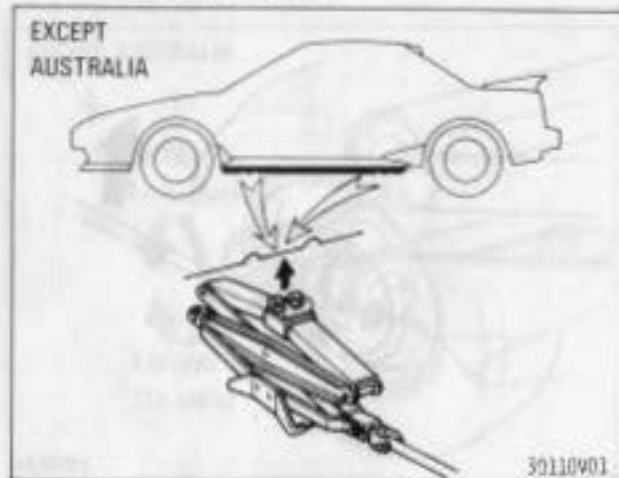

5. Position the jack at the correct jack point as shown.

Make sure that the jack is positioned on a level and solid place.

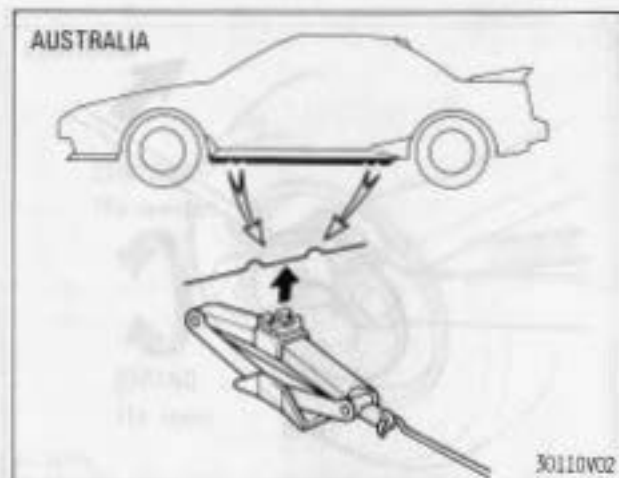

Raising your vehicle

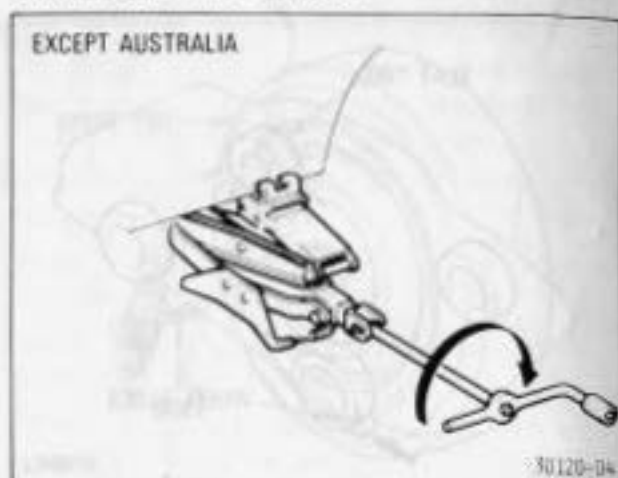

6. After making sure that no one is in the vehicle, raise it high enough so that the spare tire can be installed.

Remember that you will need more ground clearance when putting on the spare tire than when removing the flat tire.

To raise the vehicle, insert the jack handle extension into the jack (it is a loose fit) and turn it **clockwise** with the wheel nut wrench. As the jack touches the vehicle and begins to lift, double-check that it is properly positioned. **Never get under the vehicle when it is supported by a jack alone; use vehicle support stands.**

AUSTRALIA



30120001

Changing wheels



30140 01

7. Remove the wheel nuts and change tires.

Lift the flat tire straight off and put it aside. Roll the spare wheel into position and align the holes in the wheel with the bolts. Then lift up the wheel and get at least the top bolt started through its hole. Wiggle the tire and press it back over the other bolts.



30140V01

NOTE: Before putting on wheels, remove any corrosion on the mounting surfaces with a wire brush or such. Installation of wheels without good metal-to-metal contact at the mounting surface can cause wheel nuts to loosen, and eventually cause a wheel to come off while driving. Therefore after the first 1600 km (1000 miles), check to see that the wheel nuts are tight.

Reinstalling wheel nuts

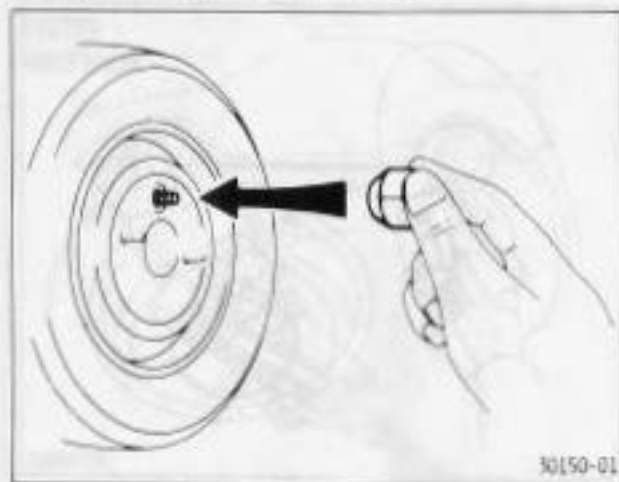

8. Reinstall all the wheel nuts finger tight.

Reinstall the wheel nuts and tighten them as much as you can by hand. Press the tire back and see if you can tighten them more.

Lowering your vehicle



9. Lower the vehicle completely and tighten the wheel nuts.

Turn the jack handle *counterclockwise* to lower the vehicle.

Use only the wheel nut wrench to tighten the nuts. Do not use your foot on the wrench or a pipe as an extension to the wrench. Make sure the wrench is securely engaged over the nut.

Tighten each nut a little at a time in the order shown. Repeat the process until all the nuts are tight.

As soon as possible after changing wheels, have a technician tighten the wheel nuts to the proper torque with a torque wrench.

Raising your vehicle



On aluminum wheels, use only a Toyota wheel nut wrench and tighten the nuts firmly by hand. Do not use a hammer or other tool to tighten the nuts. Other tools or additional leverage could damage the wheel nuts or the hub bolts.

Protecting your Toyota

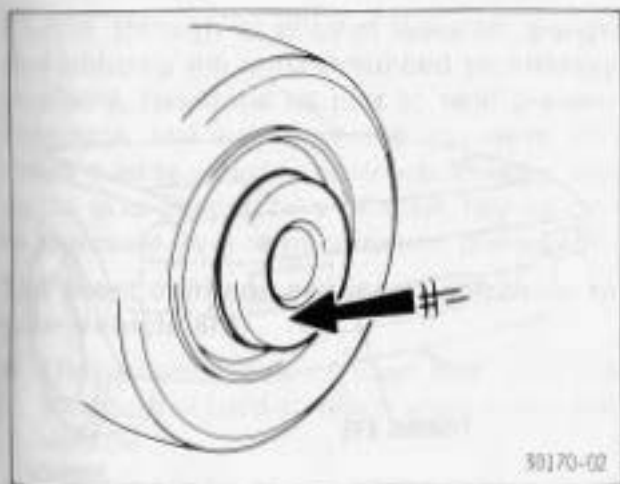
Reinstalling wheel ornament**10. Reinstall the wheel ornament.**

The wheel ornament cannot be installed on the compact spare tire.

Put the wheel ornament into position and then tap it firmly with the side or heel of your hand to snap it into place.

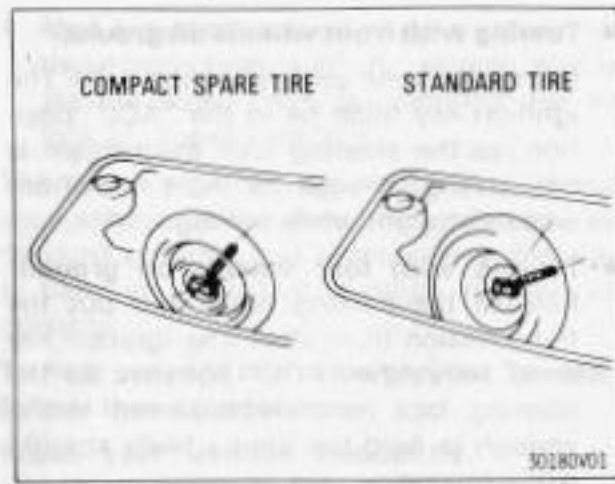
After changing wheels**11. Check the air pressure of the replaced tire. Restow all the tools, jack and flat tire securely.**

Adjust the air pressure to the specification. If the pressure is lower than specified, drive slowly to the nearest service station and fill to the correct pressure.

Do not forget to reinstall the tire inflation valve cap as dirt and moisture could get into the valve core and possibly cause air leakage. If the cap is missing, have a new one put on as soon as possible.

Notice of tire stowage

- For compact spare tire—
Securely mount the tire with its outer side facing out.
- For standard tire—
Securely mount the tire with its outer side facing in.

Before driving, make sure that all the tools, jack and flat tire are securely in place in their storage location to reduce the possibility of personal injury during a collision or sudden braking.

This is the same procedure for changing or rotating your tires.

If your vehicle needs to be towed—

If towing is necessary, we recommend you have it done by your Toyota dealer or a commercial tow truck service.

Proper equipment will help ensure that your vehicle is not damaged while being towed. Commercial operators are generally aware of the state and local laws pertaining to towing.

Your vehicle can be damaged if it is towed incorrectly. Although most operators know the correct procedure, it is possible to make a mistake. Rather than risk damage to your vehicle, why don't *you* make sure that the following few precautions are observed. If necessary, show this page to the tow truck driver.

TOWING PRECAUTIONS:

• General precaution

Use a safety chain system for all towing, and abide by the state and local laws. The vehicle can be towed from the rear only. The wheels and axle on the ground must be in good condition. If they are damaged, use a towing dolly.

• Towing with front wheels on ground

We recommend using a towing dolly. The ignition key must be in the "ACC" position, as the steering lock mechanism is not strong enough to hold the front wheels straight while towing.

• Towing with four wheels on ground:

Release the parking brake and put the transmission in neutral. The ignition key must be in the "ACC" position, as the steering lock mechanism is not strong enough to hold the front wheels straight while towing.

Never tow a vehicle with the front end raised as this may damage the front bumper,

Emergency towing

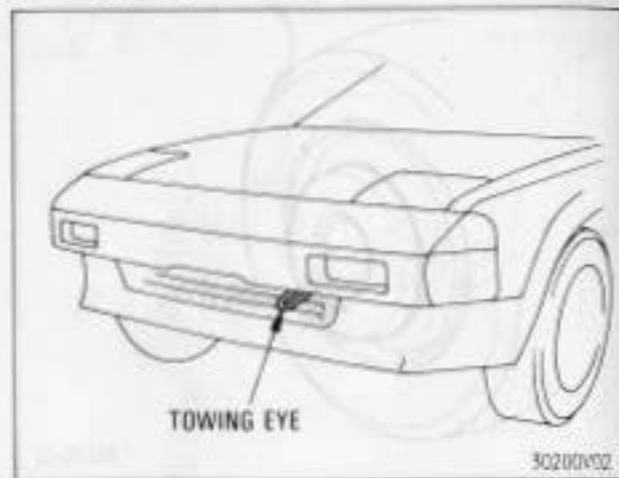

For emergency towing, secure a cable to the towing eye under the front bumper.

Use it only when your vehicle must be towed on hard-surfaced roads. A driver must be in the vehicle to steer it and operate the brakes. *If the engine is not running, the power assist for the brakes will not work so braking will be much harder than usual.* Towing in this manner must not be done if the wheels, axles, drive train, steering or brakes are damaged.

Before towing, release the parking brake and put the transmission in neutral. *The key must be in "ACC" (engine off) or "ON" (engine running).*

Corrosion prevention and appearance care—Section 4

Protecting your Toyota from corrosion

Toyota, through its diligent research, design and utilizing the most advanced technology available, has done its part to help prevent corrosion and has provided you with the finest quality vehicle construction. Now, it is up to you. Proper care of your Toyota can help ensure long-term corrosion prevention.

The most common causes of corrosion to your vehicle are:

- The accumulation of road salt, dirt and moisture in hard-to-reach areas under the vehicle
- Chipping of paint, or undercoating caused by minor accidents or by stones and gravel

Care is especially important if you live in a particular area or operate your vehicle under certain environmental conditions:

- *Road salt or dust control chemicals* will accelerate corrosion, as will the presence of salt in the air near the sea-coast or in areas of industrial pollution.
- *High humidity* accelerates corrosion especially when temperatures range just above the freezing point.
- *Wetness or dampness* to certain parts of your vehicle for an extended period of time, may cause corrosion even though other parts of the vehicle may be dry.

- *High temperatures* will cause corrosion to those components of the vehicle which are prevented from quick-drying due to lack of proper ventilation.

The above signifies the necessity to keep your vehicle, particularly the underside, as clean as possible and to repair any damage to paint or protective coatings as soon as possible.

To help prevent corrosion on your Toyota, follow these guidelines:

Wash your vehicle frequently. It is, of course, necessary to keep your vehicle clean by regular washing, but to prevent corrosion, the following points should be observed:

- If you drive on salted roads in the winter or if you live near the ocean, you should hose off the undercarriage at least once a month to minimize corrosion.
- High pressure water or steam is effective for cleaning the vehicle's underside and wheel housings. Pay particular attention to these areas as it is difficult to see all the mud and dirt. It will do more harm than good to simply wet the mud and debris without removing them. The lower edge of doors, rocker panels and frame members have drain holes which should not be allowed to clog with dirt as trapped water in these areas can cause corrosion.

Cleaning the interior

- Wash the underside of the vehicle thoroughly when winter is over.

After washing your vehicle, make sure the brakes are fully dry before driving. (See "Washing and waxing your Toyota" for more tips.)

Check the condition of your vehicle's paint and trim. If you find any chips or scratches in the paint, touch them up immediately to prevent corrosion from starting. If the chips or scratches have gone through the bare metal, have a qualified body shop make the repair.

Check the interior of your vehicle. Water and dirt can accumulate under the floor mats and could cause corrosion. Occasionally check under the mats to make sure the area is dry. Be particularly careful when transporting chemicals, cleansers, fertilizers, salt, etc., and these should be transported in proper containers. If a spill or leak should occur, immediately clean and dry the area.

Use mud shields on your wheels. If you drive on salted or gravel roads, mud shields help protect your vehicle. Full-size shields, which come as near to the ground as possible, are the best. We recommend that the fittings and the area where the shields are installed be treated to resist corrosion. Your Toyota dealer will be happy to assist in supplying and installing the shields if they are recommended for your area.

Do not park your vehicle in a damp, poorly ventilated garage. If you wash your vehicle in the garage, or if you drive it in covered with water or snow, your garage may be so damp it will cause corrosion. Even if your garage is heated, a wet vehicle can corrode in it if the ventilation is poor.

Washing and waxing your Toyota

Wash your vehicle in the shade when the body is not hot to the touch. Use a mild car-wash soap and rinse it well.

Dirt can cause small scratches in the paint and the chemicals in some dirt and air pollutants can cause deterioration of the paint and trim. Therefore, frequent washing is recommended. If you park or drive your Toyota near the ocean or on salted roads, it is especially important to prevent corrosion.

Your vehicle can be washed in an automatic car wash. Remember, however, that the paint surface could then be scratched with the brushes. Scratches reduce the paint's gloss retention and durability. They can become apparent easily, especially on the darker paints.

The following is the adequate procedure of car washing by hand.

Begin by rinsing all loose dirt off the vehicle with a hose. If the underside has picked up mud or road salt, use a hard, direct stream from a hose to remove it.

Wash with a commercial car-wash product available at your Toyota dealer or auto parts store. Follow the manufacturer's mixing instructions carefully. Do *not* use a strong household soap, detergent, gasoline or strong solvents. Dip your sponge or cloth into the wash bucket frequently and do not rub too hard — let the soap and water remove the dirt.

To clean aluminum wheels, use only a mild soap or neutral detergent.

Rinse the vehicle thoroughly. If any soap dries on the vehicle, it may cause streaking. In hot weather, you may have to rinse each section of the vehicle right after you wash it.

Dry the vehicle with a moist chamois or soft towel. The main purpose of drying is to remove excess water so that the vehicle will air dry without water spots. So do not rub or press hard, which might scratch the paint.

If you detect any stone chips or scratches in the paint, touch them up immediately to protect the bare metal from corrosion.

Polishing and waxing is recommended to maintain the original beauty of your Toyota's finish.

Maintenance facts

Always wash and dry the vehicle before you begin waxing, even if you are using a combined cleaner and wax. Road tar may be removed with turpentine. Use warm water and car-wash soap for insects and tree sap. Commercial products are also available.

Do not use gasoline or strong solvents, which may be toxic or cause damage.

Use a good quality polish and wax. If the finish has become extremely weathered, use a car-cleaning polish, followed by a separate wax.

Carefully follow the manufacturer's instructions and precautions.

Be sure to polish and wax the chrome trim as well as the paint.

Wax the vehicle again when water does not bead but remains on the surface in large patches.

To maintain the original beauty of the urethane bumpers, observe the following precautions:

- Be careful not to spill brake fluid or battery electrolyte on the bumpers. Wash any spills with water immediately.

- The bumper face is soft. Remove dirt carefully and do not scrub with abrasive cleaners.
- Protect the bumpers from high temperatures. Always remove the bumpers if your vehicle is re-painted and placed in a high heat paint waxing booth.

Touch-up paint may be used to cover small chips or scratches.

Apply the paint soon after the damage occurs or corrosion may set in. To do a good job, use a small artist's brush and stir the paint well. Make sure the area is clean and dry. To apply the touch-up paint so it is hardly noticeable, the trick is to apply it only to the bare spots. Apply only the smallest amount possible and do not paint the surface around the scratch or chip.

Cleaning the interior

The vinyl upholstery may be easily cleaned with a mild soap or detergent and water.

First vacuum over the upholstery to remove loose dirt. Then, using a sponge or soft cloth, apply the soap solution to the vinyl. After allowing it to soak in for a few minutes to loosen the dirt, remove the dirt and wipe off the soap with a clean damp cloth. If all the dirt does not come off, repeat the procedure. Commercial foaming-type vinyl cleaners are also available which work well. Follow the manufacturer's instructions. **Do not use solvent, thinner, gasoline or window cleaner on the interior.**

Use a good foam-type shampoo to clean the carpets.

Begin by vacuuming thoroughly to remove as much dirt as possible. Several types of foam cleaners are available; some are in aerosol cans and others are powders or liquids which you mix with water to produce a foam. To shampoo the carpets, use a sponge or brush to apply the foam. Rub in overlapping circles. Do not apply water—the best results are obtained by keeping the carpet as dry as possible. Read the shampoo instructions and follow them closely.

The seat belts may be cleaned with mild soap and water or with lukewarm water.

Use a cloth or sponge. As you are cleaning, check the belts for excessive wear, fraying, or cuts. *Do not use dye or bleach on the belts—it may weaken them.*

The windows may be cleaned with any household window cleaner.

When cleaning the inside of the windows, be careful not to scratch or damage the heater wires on the rear window.

Care in maintaining the surface beauty of the leather material is important as improper cleaning could result in discoloration or staining.

Apply a small amount of saddle or leather soap with a soft cloth. Allow the soap solution to loosen the soil for a few minutes. Then thoroughly wipe off all the soap solution with a damp clean cloth.

After cleaning or wherever any part of the leather gets wet, dry with a soft clean cloth. Allow it to air-dry in the shade with a breeze. Avoid direct sunlight.

Washing and waxing your Toyota

CAUTION

- Mildew may develop on soiled leather material. Be especially careful to avoid oil spots. Try to maintain your leather material in a constant clean condition.
- Long exposure to the direct rays of the sun may cause the leather surface to harden and shrink. Keep your vehicle in a shaded area, especially in the summer.
- As the interior temperature of your vehicle is apt to rise during hot summer days, avoid placing items of vinyl or plastic or containing wax on the leather material as these tend to stick to leather when warm.
- Use of a nylon brush, synthetic fiber cloth, etc. may scratch the fine grained surface of the leather.
- Never use organic substances such as benzine, alcohol and gasoline or alkaline and acid solutions for cleaning the leather as these could cause discoloring.

If you have any questions about the cleaning of your Toyota, your local Toyota dealer will be pleased to answer them.

Maintenance requirements—Section 5

Maintenance facts

TOYOTA
QUALITY SERVICE

TOYOTA
GENUINE PARTS

Regular maintenance is essential.

We urge you to protect your new vehicle by having your Toyota serviced according to the maintenance schedule given on the following pages. Regular maintenance will aid:

- Good fuel economy
- Long vehicle life
- Driving enjoyment
- Safety
- Reliability
- Warranty coverage
- Compliance with government regulations

Your Toyota has been designed for economical driving and economical maintenance. Many formerly required maintenance items are no longer required or are not required as often. To make sure that your vehicle runs at peak efficiency, follow the maintenance schedule.

Where to go for service?

It makes good sense to take your vehicle to your local Toyota dealer for service.

Toyota technicians are well-trained specialists. And they are receiving the latest service information through technical bulletins, service tips, and in-dealership training programs. They learn to work on Toyotas *before* they work on your vehicle, rather than *while* they are working on it. Doesn't that seem like the best way?

Your Toyota dealer has invested a lot of money in special Toyota tools and service equipment. It helps do the job better and at less cost.

Your Toyota dealer's service department will perform *all* of the scheduled maintenance on your vehicle—reliably and economically.

What about do-it-yourself maintenance?

Many of the maintenance items are easy to do yourself if you have a little mechanical ability and a few basic automotive tools. These items are indicated on the maintenance schedule, and simple instructions for how to perform them are presented in Section 6.

Note, however, that some maintenance tasks require special tools and skills. These are best performed by qualified technicians. Even if you are an experienced do-it-yourself mechanic, we recommend that repairs and maintenance be conducted by your Toyota dealer who will keep a record of maintenance on your Toyota. This record could be helpful should you ever require Warranty Service.

Toyota maintenance schedule —

Driving conditions under which you mainly operate your vehicle determine which maintenance schedule you follow.

In order to ensure smooth, trouble-free, safe and economical driving, Toyota provides two kinds of maintenance schedules to be selected according to your driving conditions: *normal* condition schedule and *severe* condition schedule. The instructions on which schedule to follow are given on the next page.

An odometer reading or time interval determines when service is necessary.

For most people, the odometer reading will indicate when service is needed. If, however, you drive very little, your vehicle should be serviced at regular time intervals as shown in the schedule.

Maintenance items for which do-it-yourself instructions are given in this manual (Section 6) are indicated by an asterisk (*).

You can use the asterisks to quickly locate those items you may wish to do yourself. Be sure to mark down those items that you have completed. If you are going to have your Toyota dealer complete the scheduled maintenance by doing the more skilled tasks, he will need exact information on what has already been done.

The maintenance services beyond the last period should be performed at the same intervals.

The service interval of each item can be obtained from the maintenance schedule.

Rubber hoses (for cooling and heater system, brake system and fuel system) should be inspected by a qualified technician in accordance with the Toyota maintenance schedule.

They are particularly important maintenance items. *Have any deteriorated or damaged hoses replaced immediately.* Note that rubber hoses will deteriorate with age, resulting in swelled, chafed or cracked condition.

To European and Australian owners:

Your maintenance schedule is different from the information contained in this Owner's Manual. Please refer to the separate "Toyota Service Booklet", "Toyota Warranty Booklet" or "Warranty and Service Booklet".

TOYOTA
GENUINE PARTS

WHICH SCHEDULE TO FOLLOW?

If you mainly operate your vehicle under one or more of the conditions below:

- Towing a trailer, using a camper or car top carrier
- Operating on dusty, rough, muddy or salt-spread roads
- Repeated short trips less than 8 km (5 miles) and outside temperatures remain below freezing
- Extensive idling and/or low speed driving for a long distance such as police, taxi or door-to-door delivery use

Follow
SEVERE
schedule

If you mainly operate your vehicle under:

CONDITIONS OTHER THAN THOSE LISTED ABOVE

Follow
NORMAL
schedule

— Normal condition schedule —

NORMAL

Maintenance operations:

A = Check and/or adjust as necessary. **I** = Inspect and correct or replace as necessary.
R = Replace or change. **T** = Tighten to specified torque.

SERVICE INTERVAL:

(Odometer reading or months,
whichever comes first)

x 1000 km	1	10	20	30	40	50	60	70	80
x 1000 miles	0.6	6	12	18	24	30	36	42	48
Months	—	6	12	18	24	30	36	42	48

BASIC ENGINE COMPONENTS

1	Valve clearance			A		A		A		A
2*	Drive belts			I		I		I		I
3*	Engine oil									
	Grade SE, SF or better		R	R	R	R	R	R	R	R
	Grade SD	Change every 5000 km (3000 miles) or 3 months.								
4*	Engine oil filter		R	R	R	R	R	R	R	R
5	Cooling and heater system hoses and connections (See note 1.)									I
6*	Engine coolant									
	With ethylene-glycol type anti-freeze					R				R
	With alcohol type anti-freeze			R		R		R		R
7	Oil cooler hoses (See note 1.)									I
8	Exhaust pipes and mountings									I

NOTE:

- After 80000 km (48000 miles) or 48 months, inspect every 20000 km (12000 miles) or 12 months.

Severe condition schedule

NORMAL

Maintenance operations:

A = Check and/or adjust as necessary; **I** = Inspect and correct or replace as necessary;
R = Replace or change; **T** = Tighten to specified torque.

SERVICE INTERVAL:

(Odometer reading or months, whichever comes first)

	x 1000 km	10	20	30	40	50	60	70	80
x 1000 miles	0.6	6	12	18	24	30	36	42	48
Months	-	6	12	18	24	30	36	42	48

IGNITION SYSTEM

9* Spark plugs		I	R	I	R	I	R	I	R
10 Ignition timing									I
11* Battery		I	I	I	I	I	I	I	I

FUEL AND EMISSION CONTROL SYSTEMS

12 Fuel filter					R				R
13* Air cleaner element			I		R		I		R
14 Idle speed and idle mixture	A		A		A		A		A
15 Fuel tank cap, fuel lines and connections (See note 2)					I				I
16* Clutch pedal	I								
17* Brake pedal and parking brake	I	I	I	I	I	I	I	I	I
18 Brake pads and discs		I	I	I	I	I	I	I	I
19* Brake fluid	I	I	I	I	R	I	I	I	R

NOTE

2. After 80000 km (48000 miles) or 48 months, inspect every 20000 km (12000 miles) or 12 months.

NORMAL

Maintenance operations:

A = Check and/or adjust as necessary; **I** = Inspect and correct or replace as necessary;
R = Replace or change; **T** = Tighten to specified torque

SERVICE INTERVAL: (Odometer reading or months, whichever comes first)	x 1000 km	1	10	20	30	40	50	60	70	80
	x 1000 miles	0.6	6	12	18	24	30	36	42	48
	Months	-	6	12	18	24	30	36	42	48

CHASSIS AND BODY

20	Brake line pipes and hoses	I	I	I	I	I	I	I	I	I
21	Steering wheel, linkage and gear box	-	-	I	-	I	-	I	-	I
22	Front wheel alignment (side slip)	-	-	-	-	I	-	-	-	I
23	Ball joints and dust covers	-	-	I	-	-	-	-	-	I
24*	Manual transaxle oil	Inspect every 20000 km (12000 miles) or 12 months. Change every 100000 km (60000 miles) or 60 months.								
25	Front and rear suspensions	-	-	I	-	I	-	I	-	I
26	Bolts and nuts on chassis and body	T	-	T	-	T	-	T	-	T
27	Tires and inflation pressure	-	I	I	I	I	I	I	I	I
28	All lights, horns, wipers and washer	-	I	I	I	I	I	I	I	I
ROAD TEST		-	I	I	I	I	I	I	I	I
AIR CONDITIONER/COOLER REFRIGERANT		I	-	I	-	I	-	I	-	I

— Severe condition schedule

SEVERE

Maintenance operations:

A = Check and/or adjust as necessary; **I** = Inspect and correct or replace as necessary;

R = Replace or change; **T** = Tighten to specified torque.

SERVICE INTERVAL:

(Odometer reading or months, whichever comes first.)

x 1000 km	1	5	10	15	20	25	30	35	40	45	50	55	60	65	70	75	80
x 1000 miles	0.6	3	6	9	12	15	18	21	24	27	30	33	36	39	42	45	48
Months	—	3	6	9	12	15	18	21	24	27	30	33	36	39	42	45	48

BASIC ENGINE COMPONENTS

1	Timing belt (See note 1)	Replace every 100000 km (60000 miles).															
2	Valve clearance					A					A				A		A
3*	Drive belts					I				I				I			I
4*	Engine oil	Change every 2500 km (1500 miles) or 1.5 months.															
	Grade SE, SF or better	R	R	R	R	R	R	R	R	R	R	R	R	R	R	R	R
	Grade SD																
5*	Engine oil filter	R	R	R	R	R	R	R	R	R	R	R	R	R	R	R	R
6	Cooling and heater system hoses and connections (See note 2)									I							I
7*	Engine coolant																
	With ethylene-glycol type anti-freeze									R							R
	With alcohol type anti-freeze					R				R				R			R
8	Oil cooler hoses (See note 2)									I							I
9	Exhaust pipes and mountings			I		I		I		I		I		I		I	I

NOTE:

- Applicable when your vehicle is operated mostly at idle for extensive periods and/or driven at low speeds for long distances, such as police, taxi or door-to-door delivery service. If not, replacement is not necessary.
- After 80000 km (48000 miles) or 48 months, inspect every 20000 km (12000 miles) or 12 months.

SEVERE**Maintenance operations:**

A = Check and/or adjust as necessary; **I** = Inspect and correct or replace as necessary;
R = Replace or change; **T** = Tighten to specified torque.

SERVICE INTERVAL:

(Odometer reading or months, whichever comes first.)

x 1000 km	1	5	10	15	20	25	30	35	40	45	50	55	60	65	70	75	80
x 1000 miles	0.6	3	6	9	12	15	18	21	24	27	30	33	36	39	42	45	48
Months	—	3	6	9	12	15	18	21	24	27	30	33	36	39	42	45	48

IGNITION SYSTEM

10* Spark plugs								R		I		R		I		R		I	
11 Ignition timing																			I
12* Battery			I		I		I		I		I		I		I		I		I

FUEL AND EMISSION CONTROL SYSTEMS

13 Fuel filter																			R
14* Air cleaner element (See note 3)																			Inspect every 2500 km (1500 miles) or 1.5 months. Replace every 40000 km (24000 miles) or 24 months.
15 Idle speed and idle mixture	A				A				A				A					A	
16 Fuel tank cap, fuel lines and connections (See note 4)																			I

CHASSIS AND BODY

17* Clutch pedal	I																		
18* Brake pedal and parking brake	I		I		I		I		I		I		I		I		I		I
19 Brake pads and discs		I	I	I	I	I	I	I	I	I	I	I	I	I	I	I	I	I	I
20* Brake fluid	I		I		I		I		I		R		I		I		I		R

NOTE:

3. Applicable when you mainly operate your vehicle on dusty roads. If not, apply the normal condition schedule.

4. After 80000 km (48000 miles) or 48 months, inspect every 20000 km (12000 miles) or 12 months.

SEVERE

Maintenance operations:

A = Check and/or adjust as necessary; **I** = Inspect and correct or replace as necessary;
R = Replace or change; **T** = Tighten to specified torque.

SERVICE INTERVAL:

(Odometer reading or months,
whichever comes first.)

	x 1000 km	1	5	10	15	20	25	30	35	40	45	50	55	60	65	70	75	80	
	x 1000 miles	0.6	3	6	9	12	15	18	21	24	27	30	33	36	39	42	45	48	
	Months	—	3	6	9	12	15	18	21	24	27	30	33	36	39	42	45	48	
21 Brake line pipes and hoses		I		I		I		I		I		I		I		I		I	
22 Steering wheel, linkage and gear box			I	I	I	I	I	I	I	I	I	I	I	I	I	I	I	I	
23 Front wheel alignment (side slip)										I								I	
24 Ball joints and dust covers				I		I		I		I		I		I		I		I	
25* Manual transaxle oil		Inspect every 20000 km (12000 miles) or 12 months. Change every 50000 km (30000 miles) or 30 months.																	
26 Front and rear suspensions			I		I		I		I		I		I		I		I		
27 Bolts and nuts on chassis and body		T		T		T		T		T		T		T		T		T	
28 Tires and inflation pressure			I		I		I		I		I		I		I		I		
29 All lights, horns, wipers and washer			I		I		I		I		I		I		I		I		
ROAD TEST			I		I		I		I		I		I		I		I		
AIR CONDITIONER/COOLER REFRIGERANT		I				I				I				I				I	

Do-it-yourself maintenance—Section 6

Engine compartment overview

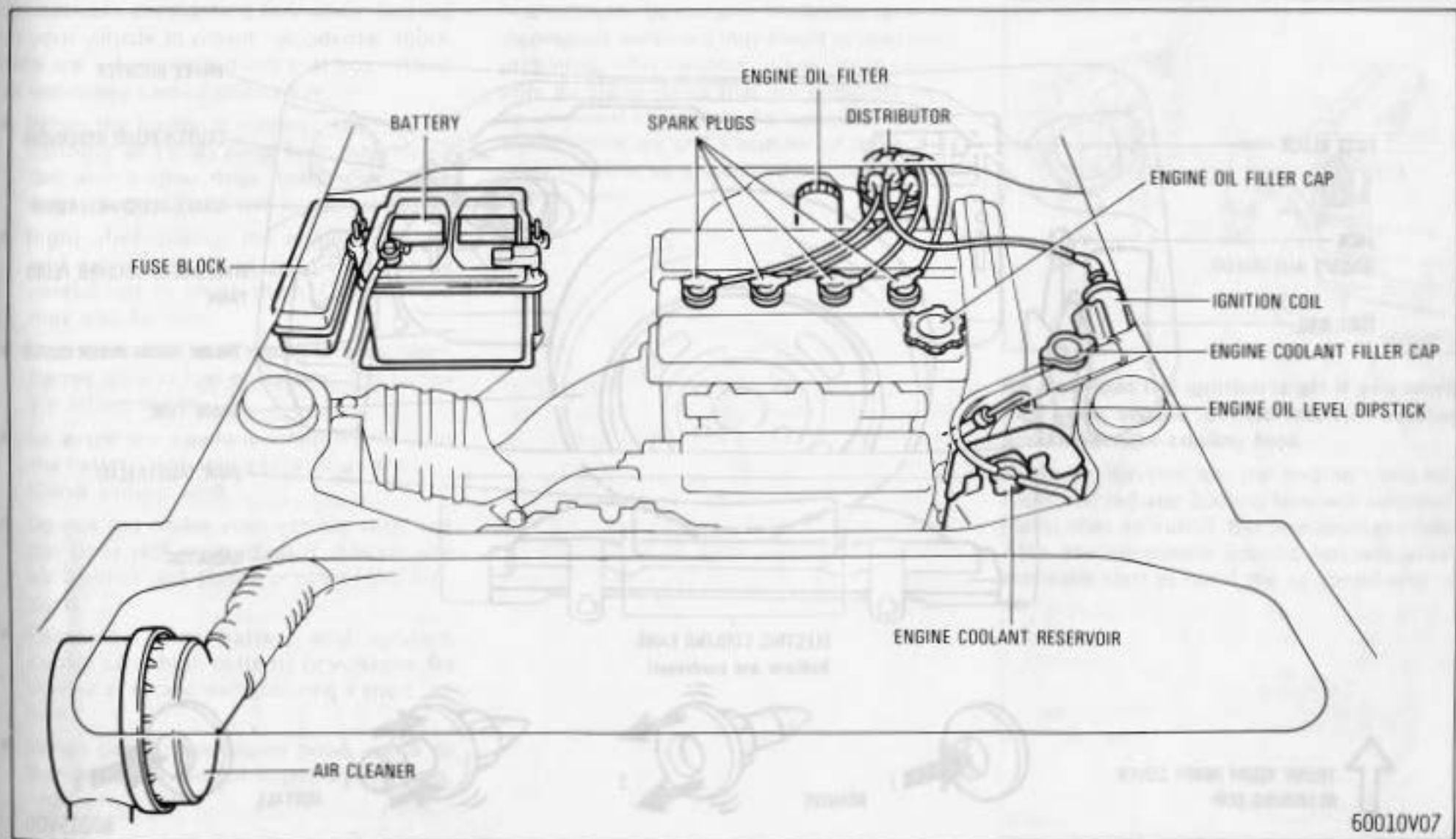

60010V07

Front trunk room overview

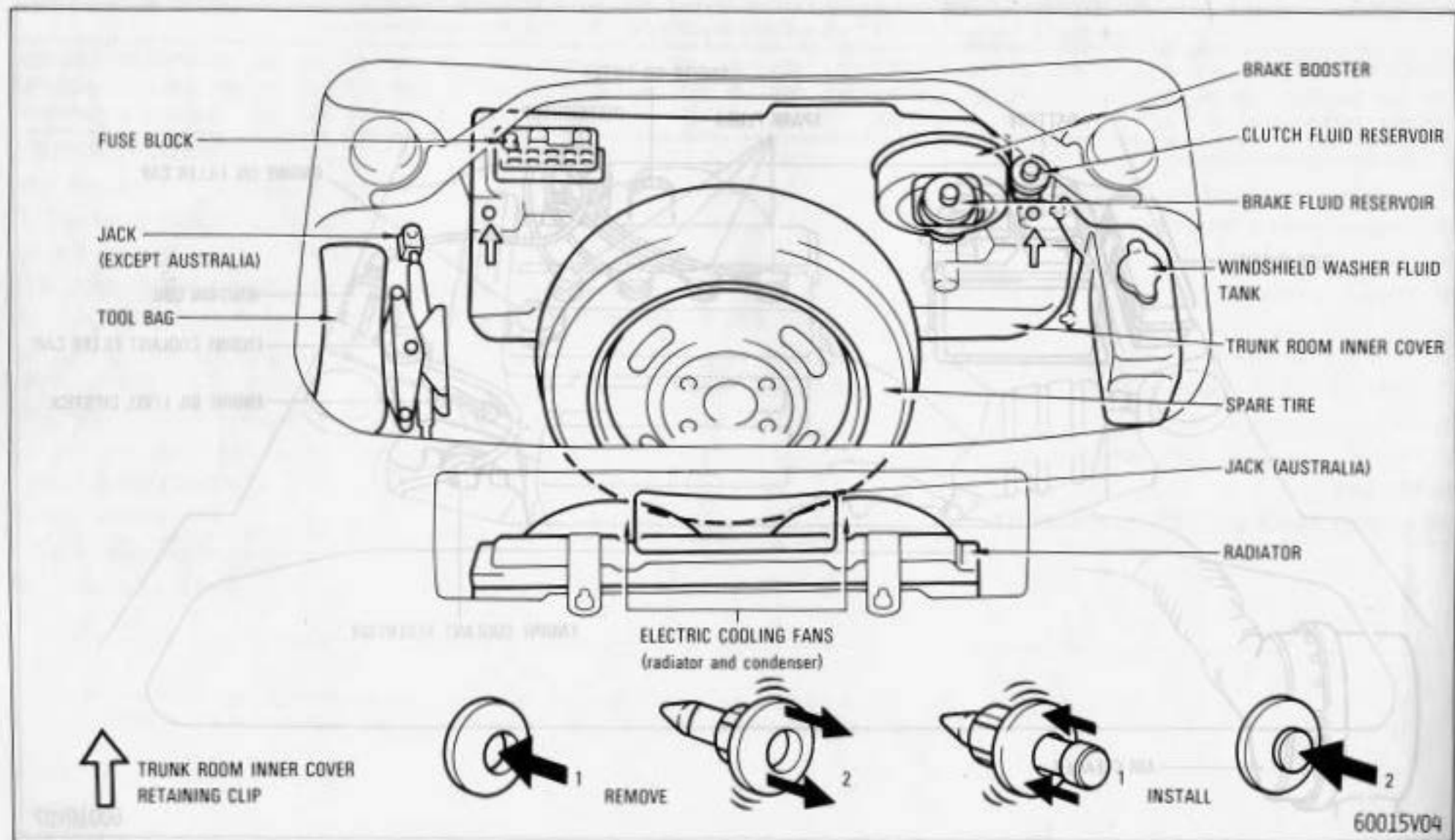

Do-it-yourself service precautions

Utmost care should be taken when working on your vehicle to prevent accidental injury. Here are a few precautions that you should be especially careful to observe:

- When the engine is running, keep hands, clothing, and tools away from the moving fan and engine drive belts. (Removing rings, watches, and ties is advisable.)
- Right after driving, the engine, radiator and exhaust manifold will be hot, so be careful not to touch them. Oil and fluid may also be hot.
- Do not smoke, cause sparks or allow open flames around fuel or battery. The fumes are inflammable.
- Be extremely cautious when working on the battery. It contains poisonous and corrosive sulfuric acid.
- Do not get under your vehicle with just the body jack supporting it. Always use automotive jack stands or other solid supports.
- Remember that battery and ignition cables carry high currents or voltages. Be careful of accidentally causing a short circuit.
- When closing the engine hood, check to see that you have not forgotten any tools, rags, etc.

You should be aware that improper or incomplete servicing may result in operating problems. This section gives instructions only for those items that are relatively easy for an owner to perform. As explained in Section 5, there are still a number of items that must be done by a qualified technician with special tools.

Electric cooling fans

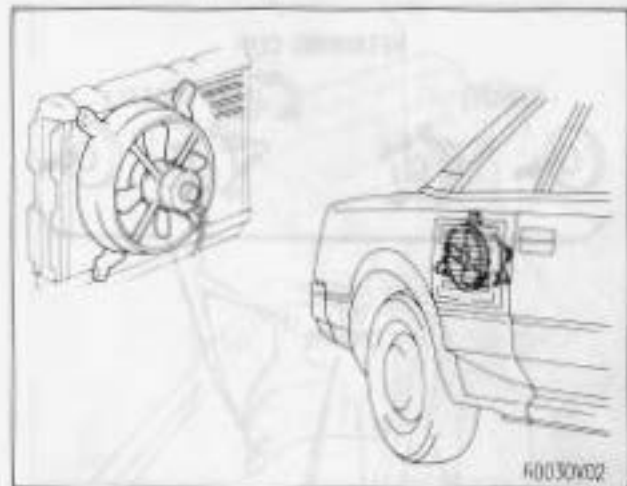

Be sure that the ignition is off if you work near the engine compartment, radiator and condenser cooling fans.

With the ignition on, the engine compartment and radiator cooling fans will automatically start to run if the temperatures rise. Also, the condenser cooling fan will automatically start to run if the air conditioner is on.



Adjusting the fuel control connector (European models with catalytic converter)

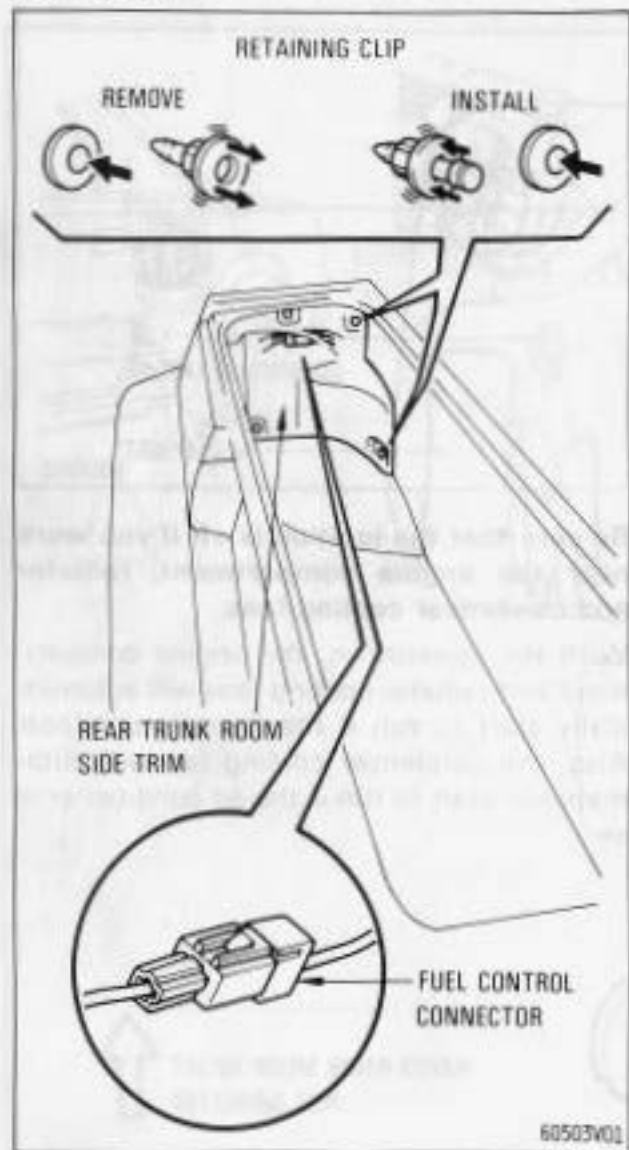

The fuel control connector is located in the rear trunk room, and it is adjusted for use of gasoline with 95 octane number or higher at the factory.

If you cannot obtain the gasoline with the octane number designated above by any means, you need to readjust the fuel control connector for use of gasoline with 91 octane number or higher.

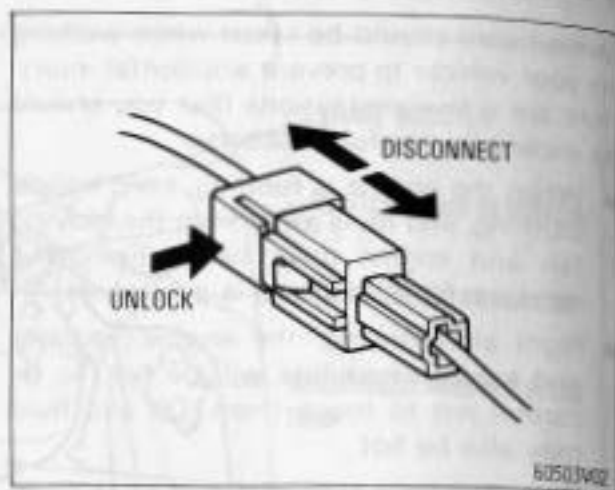

To readjust the fuel control connector:

1. Remove the retaining clips and take off the rear trunk room side trim.
2. Disconnect the fuel control connector while pushing the lock release.

To resume the use of gasoline with 95 octane number or higher, reconnect the connector after filling the tank up with the gasoline two or three times.

Checking the engine oil level

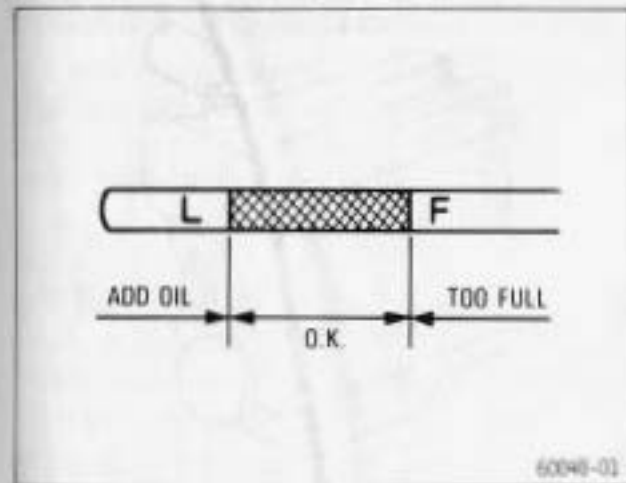

With the engine at operating temperature and turned off, check the oil level on the dipstick.

1. To get a true reading, the vehicle should be on a level spot. After turning off the engine, wait a few minutes for the oil to drain back into the bottom of the engine.
2. Pull out the dipstick, and wipe it clean with a rag.
3. Reinsert the dipstick – push it in as far as it will go, or the reading will not be correct.
4. Pull the dipstick out and look at the oil level on the end. If it is between the "F" and "L" marks, it is O.K. If the oil level is below the "L" mark (or not even showing on the dipstick), add oil up to the "F" line immediately.

Avoid overfilling, or the engine could be damaged.

Oil grade and viscosity recommendations are given below.

Recommended grade (API):

Europe and Australia

SE, SF or better

Others

SD, SE, SF or better

Recommended viscosity (SAE):

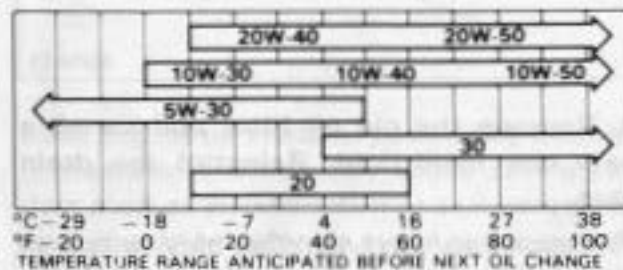

TEMPERATURE RANGE ANTICIPATED BEFORE NEXT OIL CHANGE

Changing the engine oil and filter

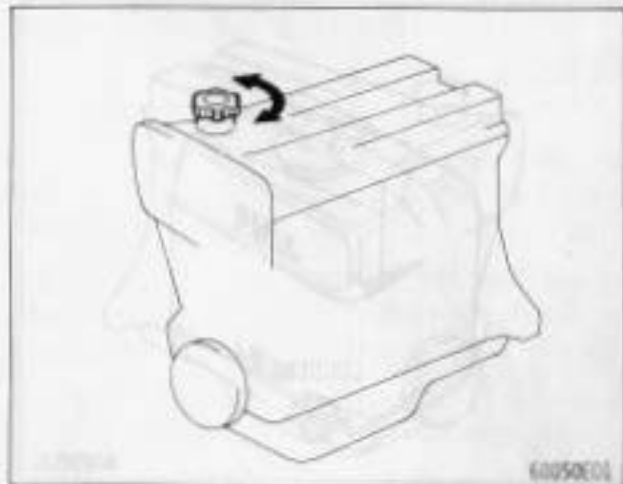

1. Warm up the engine for a few minutes and then turn it off. Remove the oil filler cap.

- a. Park the vehicle on a level spot. Warm up the engine until the needle on the temperature gauge is at least above the bottom mark. (Warm oil will drain faster and more thoroughly.) Turn the engine off.
- b. Remove the oil filler cap. This allows air to enter the engine as the oil drains.

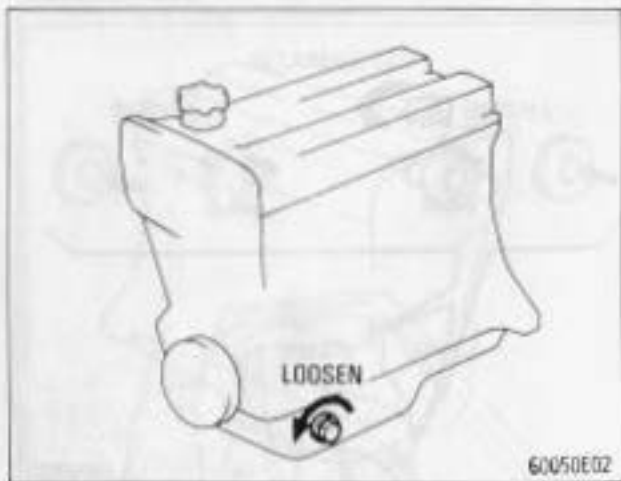

2. Remove the drain plug and allow the oil to drain fully.

- a. Place a drain pan under the drain plug.
- b. Using a wrench, remove the drain plug. *The oil may be hot—be careful not to burn yourself.* Allow the oil to drain fully.



3. Remove the old oil filter and install a new one hand-tight. Reinstall the drain plug.

The engine exhaust manifold may be hot, so be careful.

- a. Using an oil filter wrench (any of several common types will work), loosen the oil filter. It turns counterclockwise. Once loose, you may unscrew it the rest of the way by hand. When removing it, hold up the end so that oil does not spill out.
- b. With a clean rag, wipe off the mounting surface on the engine so that the new filter will seat well. *Make sure that the old gasket has not stuck to the mounting surface.* If it has, remove it before installing the new filter.



c. Smear a little engine oil on the rubber gasket of the new oil filter.

- d. Screw the new filter into place and tighten it until the gasket contacts the seat. Then give it additional 3/4 turn to seat the filter.
- e. Reinstall the drain plug and gasket. Tighten the plug with your wrench, but do not force it and strip the threads.

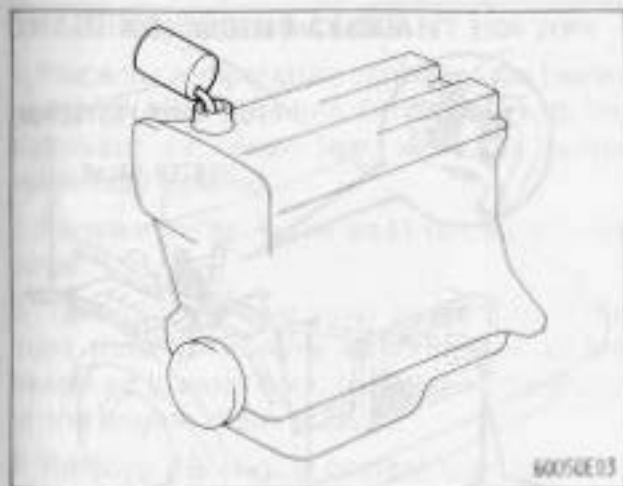

4. Add oil and install the filler cap. Start the engine and check for leaks at the filter or drain plug.

- After adding the oil, make sure that the filler cap is installed hand-tight. You should double-check the oil level on the dipstick. Engine oil additives are neither needed nor recommended.
- With the engine running, look carefully for any small leaks from around the oil filter or drain plug. Any leak indicates a faulty installation.
- Turn the engine off and wait a few minutes. Check the oil level again and add oil if necessary.

Used engine oil contains potentially harmful contaminants which may cause skin disorders such as inflammation or skin cancer, so care should be taken to avoid prolonged and repeated contact with it. To remove used engine oil from your skin, wash thoroughly with soap and water.

Do not leave used oil within the reach of children.

Dispose of used oil only in a safe and acceptable manner. Do not dispose of used oil in household trash, in sewers or onto the ground. Call your dealer or a service station for information concerning recycling or disposal.

Checking the engine coolant level

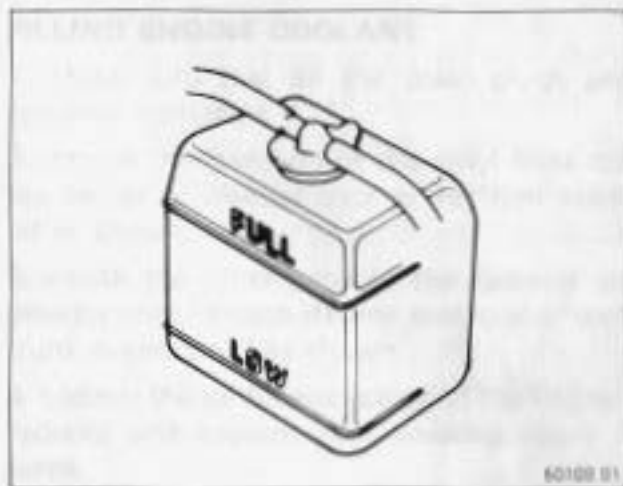

Look at the see-through coolant reservoir tank. The coolant level is satisfactory if it is between the "FULL" and "LOW" lines on the tank.

The coolant level in the reservoir tank will vary with engine temperature. However, if the level is on or below the "LOW" line, add coolant. Bring the level up to the "FULL" line.

When adding coolant, all you have to know is what kind of coolant is already in the cooling system. *Always use the same type as already in the system.*

Checking the engine coolant level



If the coolant level drops within a short time after replenishing, there may be a leak in the system. Visually check the radiator, hoses, engine coolant filler cap, drain plugs, air bleeder plugs and water pump.

If no leak can be found, have the cap pressure tested at your Toyota dealer. **To prevent burning yourself, do not remove the engine coolant filler cap when the engine is hot.** See "If your vehicle overheats" in Section 3 for instructions and precautions.

Changing the engine coolant

As this vehicle requires special engine coolant changing procedure, work properly as described below.

Failure to do so could result in serious damage to your engine.

If you are not sure how to change the engine coolant, have it done by your Toyota dealer.

CHANGING PRECAUTIONS

- Park the vehicle on a level spot. If not, it will cause incomplete engine coolant draining and cooling system air bleeding.
- **To prevent burning yourself, do not remove the engine coolant filler cap and drain plugs if the engine is hot.**
- For information on freeze protection, read the antifreeze container. Follow the manufacturer's directions for how much to mix with water. The total capacity of the cooling system is given in Section 8. We recommend more than 50 % solution (but no more than 70 %) be used for your Toyota, or a sufficient quantity to provide protection to about -35°C (-31°F). For information on antifreeze, see also "Winter driving tips" in Section 2.
- If you spill some of the coolant, be sure to wash off with water to prevent it from damaging the parts or painting.

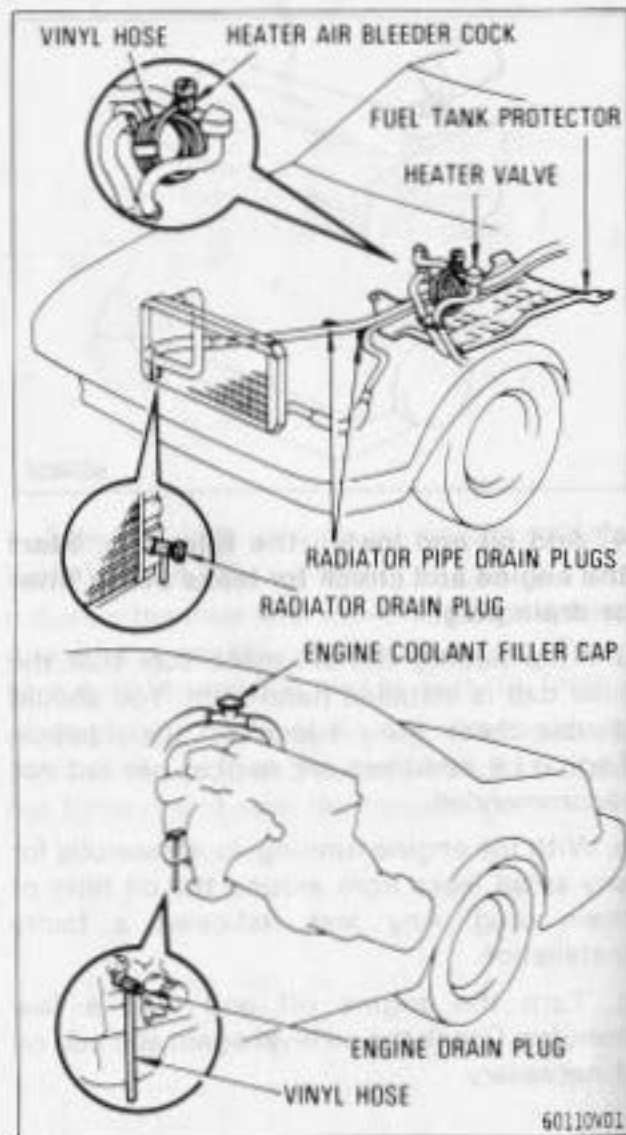

DRAINING ENGINE COOLANT

1. Place the temperature control of the heater to the "WARM" position. On models with the automatic air conditioner, leave the heater valve fully opened.
2. Remove the spare tire and front trunk inner cover.
3. Take out the two vinyl hoses out of the front trunk room. One is connected to the heater air bleeder cock. Install the other hose to the engine drain cock.
4. Remove the engine coolant filler cap.
5. Loosen the engine drain plug.
6. Remove the fuel tank protector under the body.
7. Remove the two radiator pipe drain plugs and gaskets.

If the gaskets are damaged, replace them with new ones.

8. Loosen the radiator drain plug.
9. After draining the engine coolant thoroughly, close all the drain plugs securely.
10. Remove the vinyl hose from the engine drain cock.

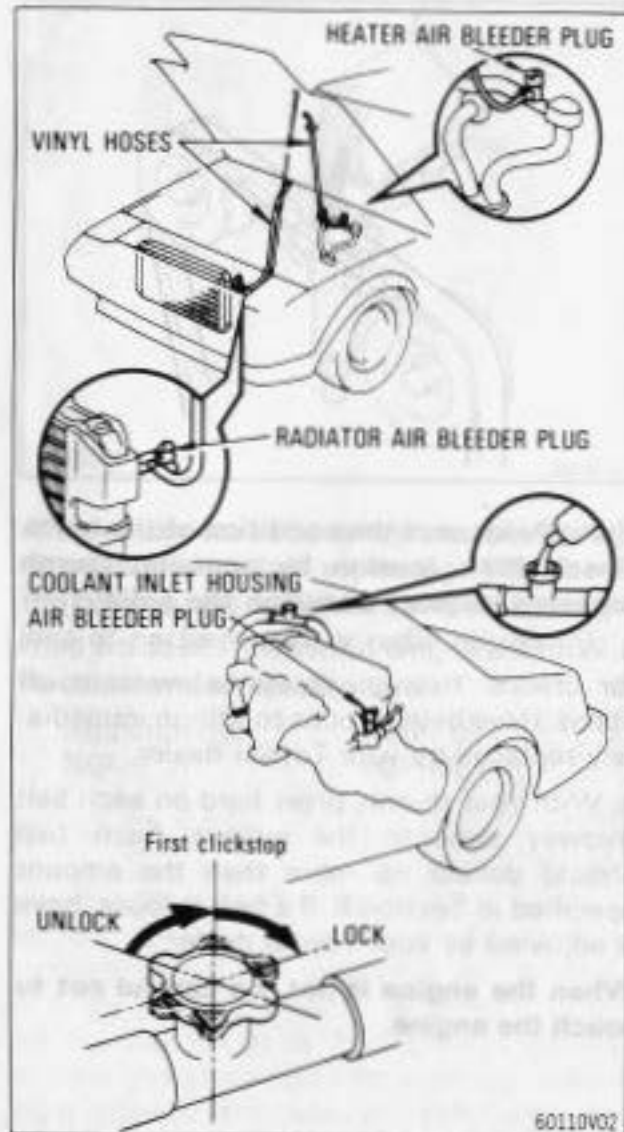

FILLING ENGINE COOLANT

1. Make sure that all the drain plugs are securely tightened.
2. Attach the free end of the vinyl hose for the heater air bleeder cock to the front trunk lid as shown.
3. Install the other hose to the radiator air bleeder cock. Attach its free end to the front trunk support rod as shown.

4. Loosen the air bleeder plugs of the heater, radiator and coolant inlet housing about 3 turns.

Make sure that the vinyl hoses are not kinked or folded.

5. Pour the antifreeze into the engine coolant filler hole. Then fill with clean water until the coolant overflows from the air bleeder cock of the coolant inlet housing.
6. Close the air bleeder plug of the coolant inlet housing securely.
7. Add water slowly and top off the filler hole with water.

Make sure that the water levels of both vinyl hoses are about the same height of the filler hole. If not, check the hoses for kinks.

8. Wait for a few minutes and add water again until the water level does not drop.
9. Close all the air bleeder plugs securely.
10. Install the filler cap and place it at the first clickstop.

Never turn the filler cap fully clockwise.

11. Start the engine and run it at a fast idle speed for several minutes. Then stop the engine.
12. Check the water level in the filler hole. If it drops, add water and repeat the steps from 10 to 12.
13. Lock the filler cap securely.
14. Add water into the engine coolant reservoir and bring the level up to the "FULL" line.
15. Start the engine again and **make sure that all the drain and bleeder plugs are not leaking.**
16. Reinstall the fuel tank protector, vinyl hoses, front trunk inner cover and spare tire.

After changing the engine coolant, check the water levels in the engine coolant filler cap and reservoir one or two times within one week or 500 km (300 miles).

Checking the engine drive belts

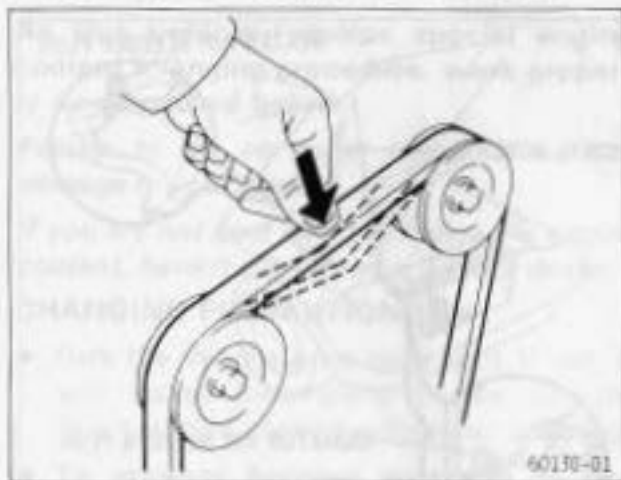

Visually inspect the condition of the belts. Check their tension by applying thumb pressure midway between the pulleys.

- a. With the engine turned off, check the belts for cracks, fraying, excessive wear or oil stains. Have belts in poor condition immediately replaced by your Toyota dealer.
- b. With your thumb, press hard on each belt midway between the pulleys. Each belt should deflect no more than the amount specified in Section 8. If a belt is loose, have it adjusted by your Toyota dealer.

When the engine is hot, be careful not to touch the engine.

Checking and replacing the air cleaner element

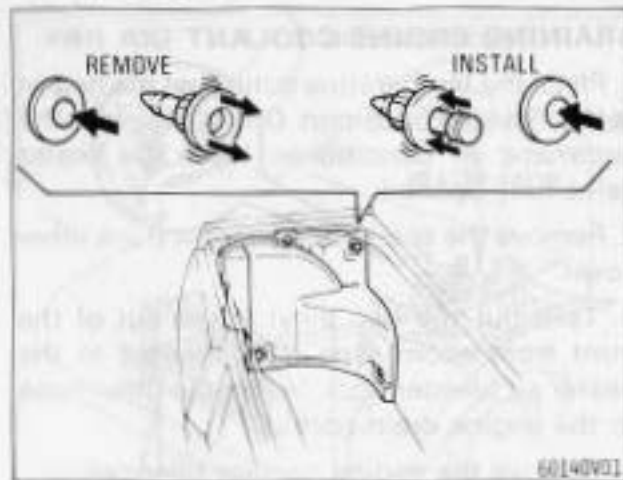

1. To inspect the element, remove the retaining clips and take off the rear trunk room side trim.

The clips can be easily removed by working the center pin as shown in the illustration.

Replacing spark plugs (vehicles with catalytic converter)

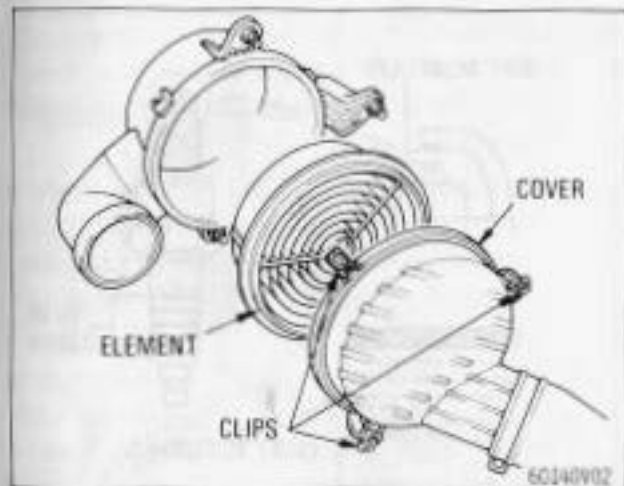

2. Release the clips and remove the cover and take out the element.

Pull the wire tab to release each clip.

Inspect the outer surface of the element. If it is dirty, it should be replaced. If it is just moderately dusty, it may be cleaned by blowing compressed air from the *inside* surface. Do **not** wash or oil the element.

When installing an element, be sure to remove any dust from where the element seats and put the element properly in place.

Do not drive with the air cleaner removed, or excessive engine wear could result. Also backfiring could cause a fire in the rear trunk room.

Replacing spark plugs (vehicles without catalytic converter)

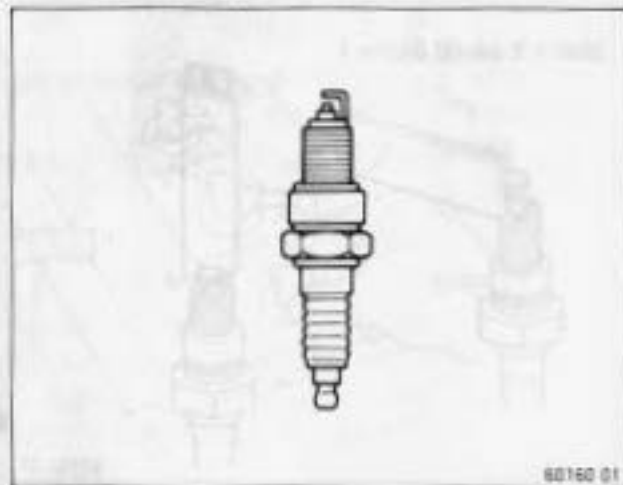

Always use the recommended spark plugs or equivalent when replacing. The use of the other plugs will cause engine damage, loss of performance or radio noises.

Recommended spark plugs:

Nippondenso	Q20R-U11
NGK	BCPR6EY11

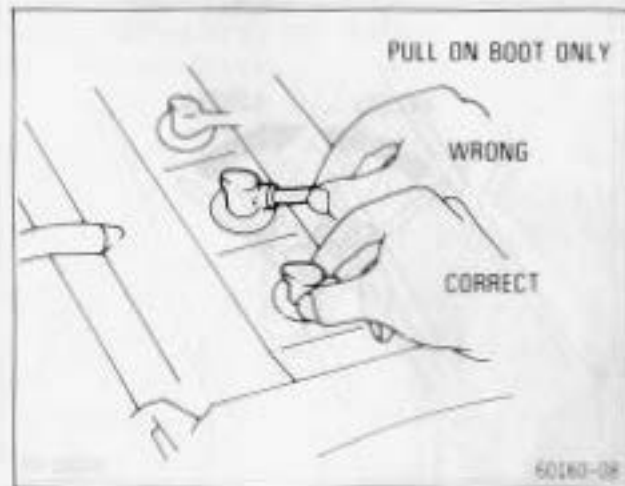

1. Unfasten the spark plug cables by pulling on the boot, not on the cable itself.

a. Note the order of the spark plug cables. If you are not positive that you can reconnect them correctly, mark each cable with a number on a piece of tape before disconnecting it.

b. Unfasten the connector by pulling straight up. Pulling on the cables may break the carbon conductor inside. **The boots may be hot, so be careful.**

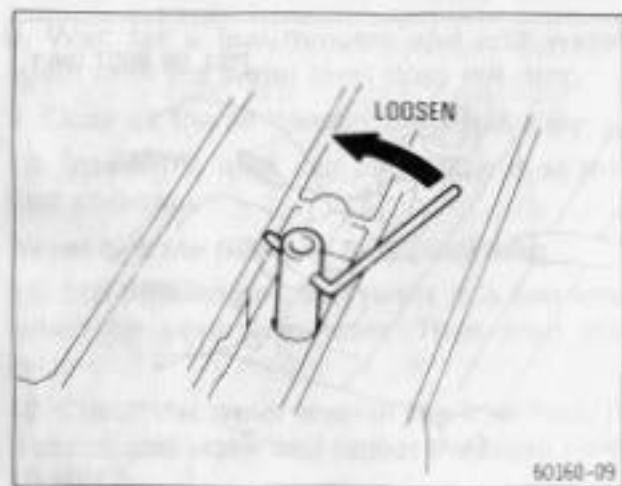

2. Unscrew and remove the old spark plugs.

Keep the plugs in order as you remove them. *The spark plugs may be hot, so be careful.* If the plug condition is normal, discard the plugs. One clue to judging the plug condition is the deposits. If the plugs have anything other than brown to light tan (or grey) deposits on them, that may indicate the engine needs adjustments or repairs. Save them and show them to your Toyota dealer.

Do not allow dirt or anything else to fall through the spark plug holes.

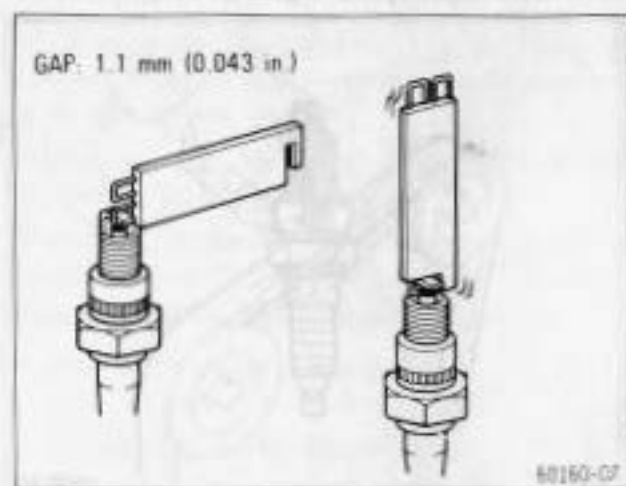

3. Set the gap on the new plugs to the correct clearance, and install them. Reconnect the spark plug cables in the correct order.

a. Check the gap by passing the feeler gauge between the electrodes on the spark plug. If the gap is correct, you will feel a slight drag. If necessary, bend the outer electrode to obtain the right clearance. *Do not pry against the center electrode.*

b. Screw in the plugs *by hand* as far as it will go. If necessary, a spark plug wrench may be used for an extension. If a plug does not screw in smoothly, remove it and try again to ensure the correct engagement of the threads on the spark plug with the threads in the hole. This prevents the threads from stripping in the next step.



c. Tighten the plugs with a spark plug wrench. Do not overtighten.

d. Make sure the cables are installed in the correct order. The connector fastens on by pushing it squarely over the end of the plug.

Replacing spark plugs (vehicles with catalytic converter)

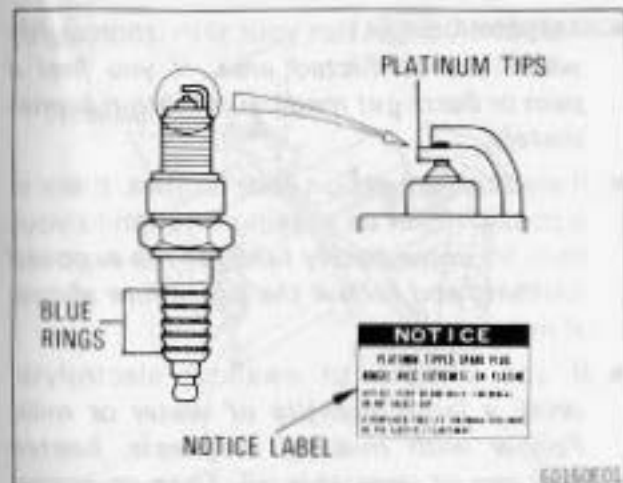

The platinum-tipped spark plugs in your engine do not require replacement as frequent as the conventional type. They will last much longer than the conventionals. Replacement interval is 100000 km (60000 miles). *Do not reuse them by cleaning or regapping.* The platinum-tipped spark plugs are identified by blue rings on the ceramic.

Always use the recommended spark plugs or equivalent when replacing. The use of the other plugs will cause engine damage, loss of performance or radio noises.

Recommended spark plugs:

Nippondenso	PQ16R
NGK	BCPR5EP11

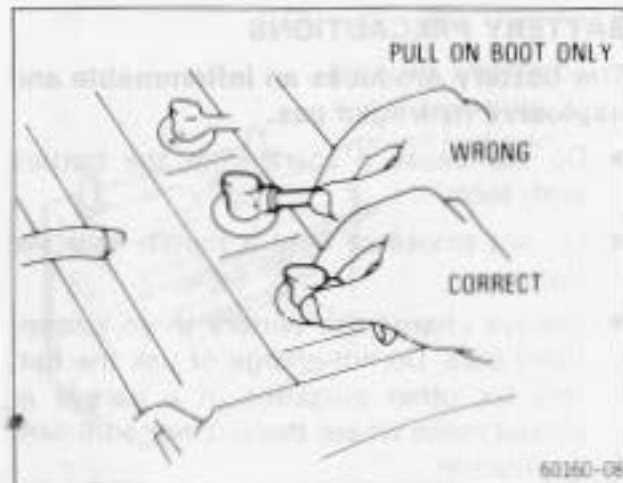

1. Unfasten the spark plug cables by pulling on the boot, not on the cable itself.

a. Note the order of the spark plug cables. If you are not positive that you can reconnect them correctly, mark each cable with a number on a piece of tape before disconnecting it.

b. Unfasten the connector by pulling straight up. Pulling on the cables may break the carbon conductor inside. *The boots may be hot, so be careful.*

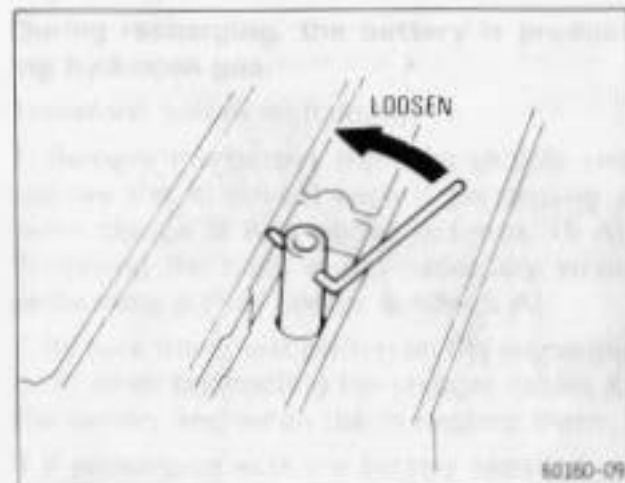

2. Unscrew and remove the old spark plugs. Install new spark plugs and reconnect the spark plug cables in the correct order.

The spark plugs may be hot, so be careful.

Do not allow dirt or anything else to fall through the spark plug holes.

a. Screw in the plugs *by hand* as far as it will go. If necessary, a spark plug wrench may be used for an extension. If a plug does not screw in smoothly, remove it and try again to ensure the correct engagement of the threads on the spark plug with the threads in the hole. This prevents the threads from stripping in the next step.

b. Tighten the plugs with a spark plug wrench. Do not overtighten.

Checking battery condition and fluid level

BATTERY PRECAUTIONS

The battery produces an inflammable and explosive hydrogen gas.

- Do not cause a spark from the battery with tools.
- Do not smoke or light a match near the battery.
- Always charge the battery in an unconfined area. Do not charge or use the battery for other purposes in a garage or closed room where there is not sufficient ventilation.

The electrolyte contains poisonous and corrosive sulfuric acid.

- Avoid contact with eyes, skin or clothes.
- Never ingest electrolyte.
- Wear protective safety glasses when working near the battery.
- Keep children away from the battery.

EMERGENCY MEASURES

- If electrolyte gets in your eyes, **flush your eyes with clean water for at least 15 minutes and get immediate medical attention.** If possible, continue to apply water with a sponge or cloth while enroute to the medical office.



c. Make sure the cables are installed in the correct order. The connector fastens on by pushing it squarely over the end of the plug.

- If electrolyte gets on your skin, **thoroughly wash the contacted area. If you feel a pain or burn, get medical attention immediately.**
- If electrolyte gets on your clothes, there is a possibility of its soaking through to your skin, so **immediately take off the exposed clothing and follow the procedure above, if necessary.**
- If you happen to swallow electrolyte, **drink a large quantity of water or milk. Follow with milk of magnesia, beaten raw egg or vegetable oil. Then go immediately for emergency help.**

BATTERY HANDLING SAFETY

- Never perform any maintenance on the battery or recharge it while the engine is running. Also, be sure all accessories are turned off.
- Remove the ground cable first and reinstall last.

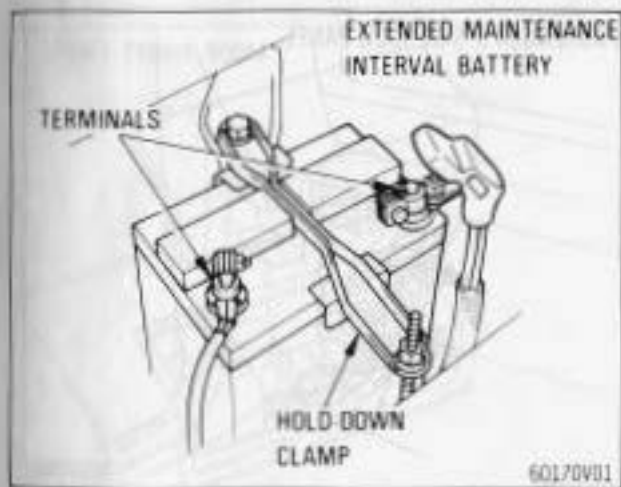

1. Check the battery for corroded or loose connections, cracks, or loose hold-down clamps.

- a. If the battery is corroded, wash it off with a solution of warm water and baking soda. *Take care that no solution gets into the battery.* Coat the outside of the terminals with grease to prevent further corrosion.
- b. If the connections are loose, tighten the clamp bolts—but do not overtighten. *Be careful not to cause a short circuit with tools.*
- c. Tighten the hold-down clamp only enough to keep the battery firmly in place. Overtightening may damage the battery case.

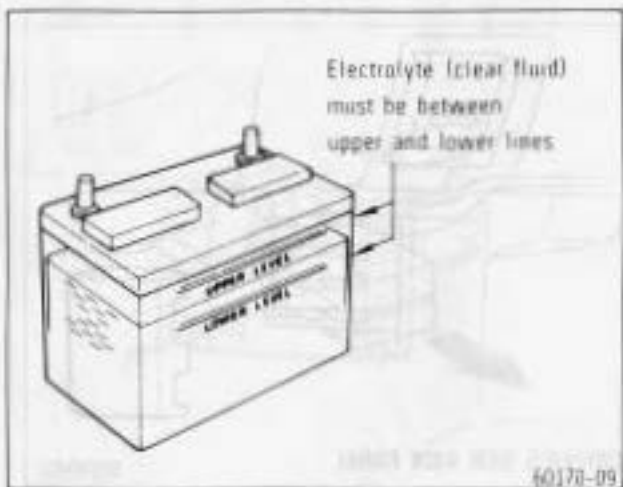

2. Check the electrolyte level as shown above. If the level is low, add distilled water.

- a. When checking the electrolyte level, look at all six cells, not just one or two.
- b. Use only distilled water to replenish the battery. **Do not overfill**—the electrolyte may squirt out of the battery during periods of heavy charging, causing corrosion or damage.
- c. After replenishing, be sure to securely retighten the filler/vent caps.

Battery recharging precautions

During recharging, the battery is producing hydrogen gas.

Therefore, before recharging:

1. Remove the battery from the vehicle and remove the filler/vent caps if performing a quick charge (6 A or above but max. 15 A). Removing the caps is not necessary when performing a slow charge (under 5 A).
2. Be sure the power switch on the recharger is off when connecting the charger cables to the battery and when disconnecting them.
3. If recharging with the battery installed on the vehicle, be sure to disconnect the ground cable.

Fuse and circuit breaker locations

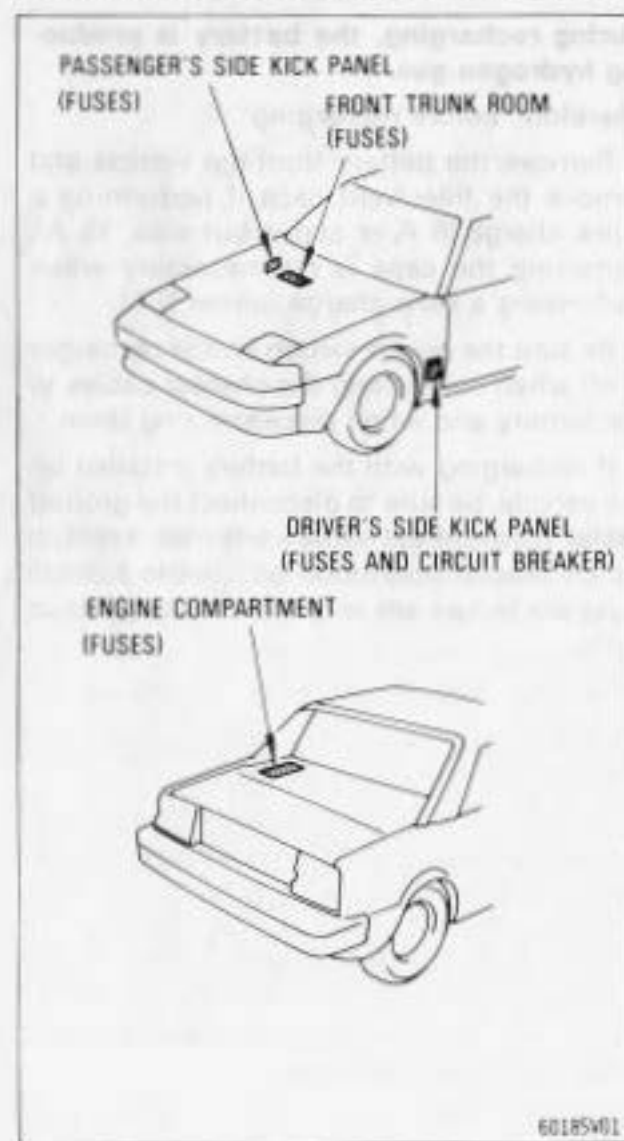

Checking battery condition

Checking and replacing fuses

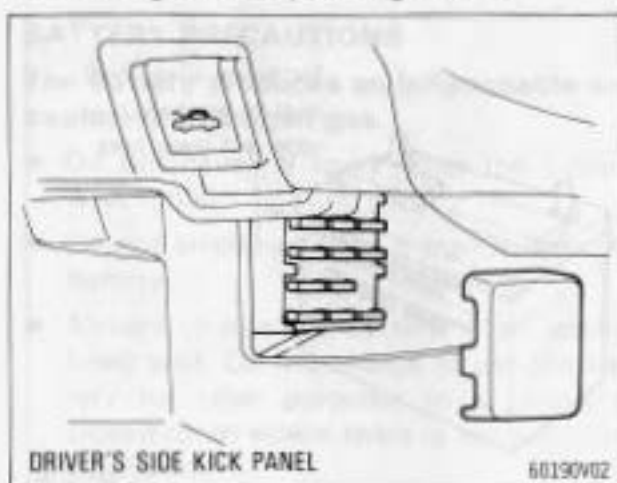

1. Turn the ignition switch off and open the fuse box lid.

If any light or electrical component does not work, your vehicle may have a blown fuse.

Determine which fuse may be causing the problem. The lid of the fuse box shows the name of the circuit for each fuse. (If necessary, Section 8 gives the name of the circuit for each fuse.)

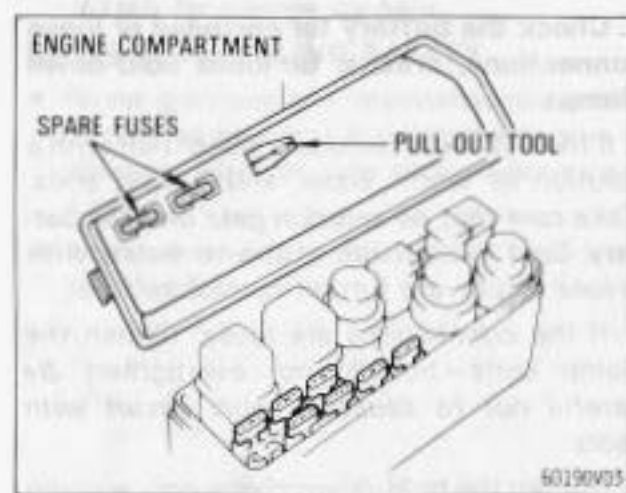
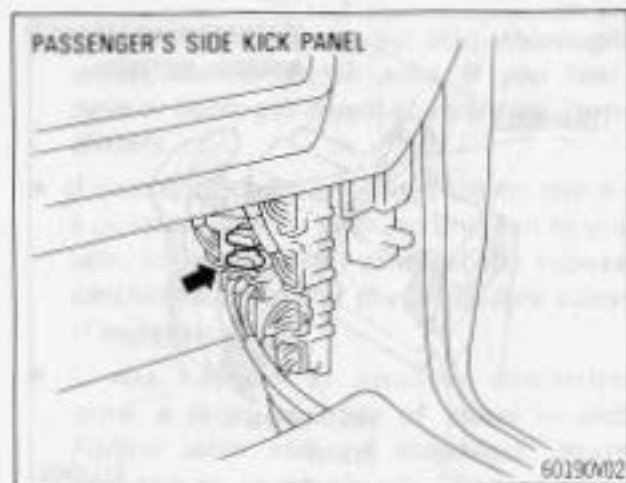

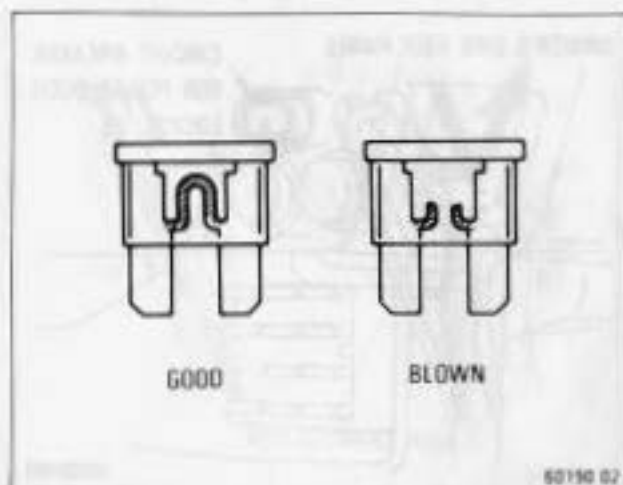
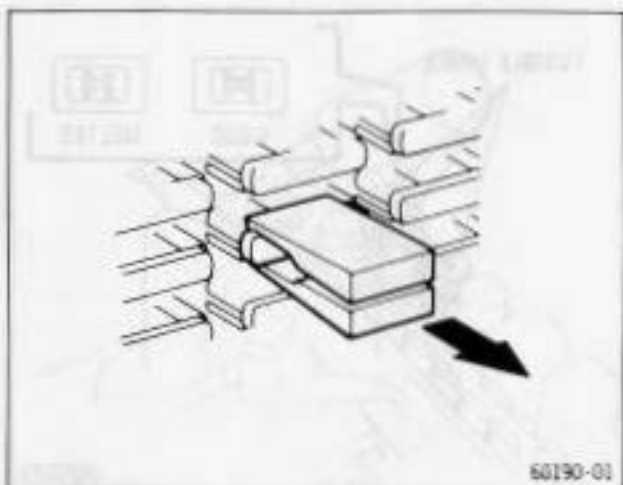
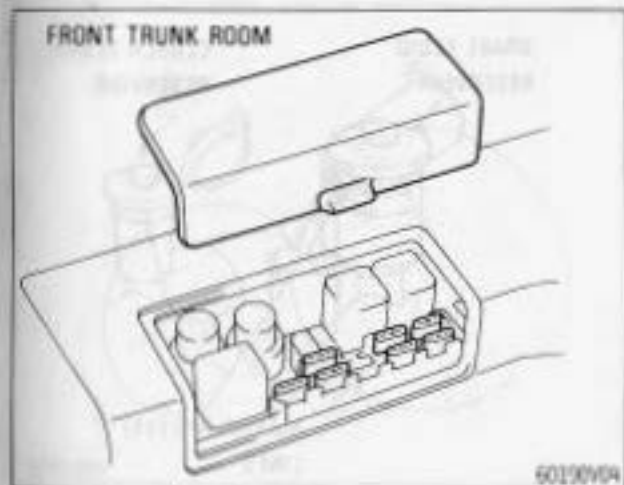

2. Be sure the inoperative component is off. Pull a suspected fuse straight out with the pull-out tool and check it. If it has blown, push a new fuse into the clips.

a. Look carefully at the fuse. If the thin wire is broken, the fuse has blown. If you are not sure or if it is too dark to see, try replacing the suspected fuse with one that you know is good.

b. Install only a fuse with an amperage rating designated on the fuse box lid. **Never use a fuse with a higher amperage rating nor some other object in place of a fuse.**

c. If the new fuse immediately blows out, there is a problem with the electrical system. Have your Toyota dealer correct it as soon as possible.

If you do not have a spare fuse, in an emergency you can pull out the "RAD CIG", "DOME", "A/C" or "HEATER" fuse, which may be dispensable for normal driving, and use it if its amperage rating is the same.

If you cannot use one of the same amperage, use one with a lower than, but as close as possible to, the same rating. If the amperage is lower than that specified, the fuse might blow out again but this does not indicate anything wrong. Be sure to get a correct fuse as soon as possible and return the substitute to its original clips.

NOTE: It is a good idea to purchase a set of spare fuses and keep them in your vehicle for emergencies.

Checking the circuit breaker

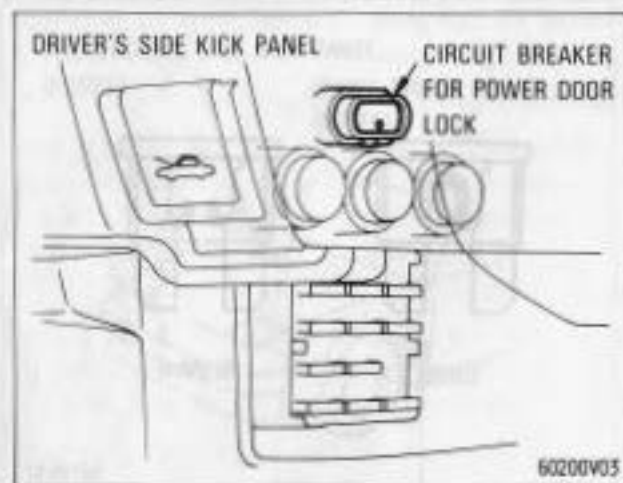

In event the power door lock does not operate, check the circuit breaker (C.B).

a. To re-set the circuit breaker, carefully insert a thin object, such as a toothpick, needle or safety pin, into the hole in the circuit breaker until you hear a click. The component should now operate. This may be done without removing the circuit breaker.

b. If the circuit breaker immediately goes off again or the component does not operate, have the electrical system checked by your Toyota dealer as soon as possible.

Checking the fusible links

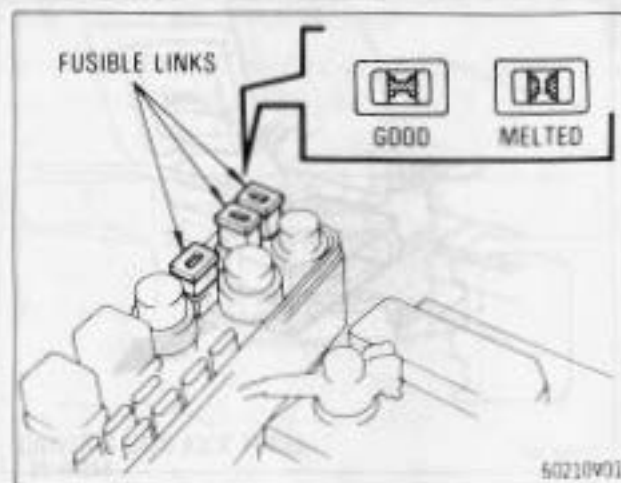

If the headlights or other electrical components do not work and the fuses are O.K., check the fusible links. If any of the links is melted, it must be replaced.

Always use a genuine Toyota fusible link for replacement. Never install a wire — even for a temporary fix. It may cause extensive damage and possibly a fire.

If there is an overload in the circuits from the battery, the fusible links are designed to melt before the entire wiring harness is damaged. *Before replacing the fusible links, the cause of electrical overload should always be determined and repaired by your Toyota dealer.*

Checking brake and clutch fluid

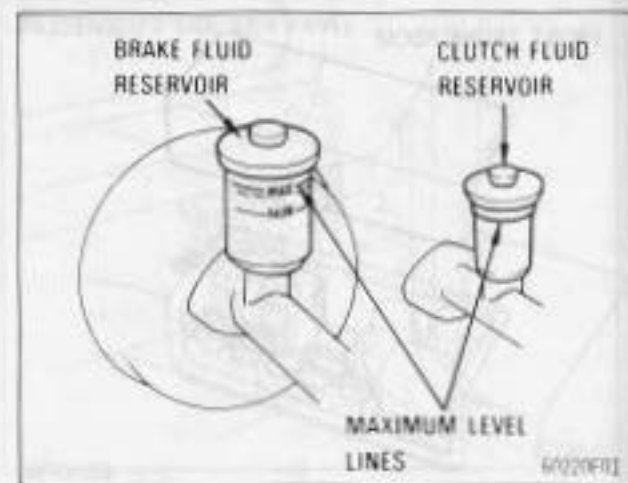

To check the fluid levels, simply look at the see-through reservoirs. The brake and clutch fluid levels should be within 10 mm (0.4 in.) and 5 mm (0.2 in.) respectively below each maximum level line.

It is normal for the brake fluid level to go down slightly as the brake pads wear. So be sure to keep the reservoirs filled.

If any reservoir needs frequent refilling, it may indicate a serious mechanical problem.



If the level is low, add SAE J1703 or DOT 3 brake fluid to the brake or clutch reservoir.

Fill the brake fluid to the dotted line. This brings the fluid to the correct level when you put the cover back on.

Use caution in filling the reservoirs because brake fluid can harm your eyes and damage painted surfaces.

Do not use brake fluid that has been opened for more than 1 year or that has had the cap left off. Brake fluid absorbs moisture from the air, and excess moisture can cause a dangerous loss of braking. Also, for this reason you should have the brake fluid drained and replaced periodically. Remove and replace the reservoir covers by hand.

Adding washer fluid



If the windshield washer does not work, the washer tank may be empty. Add washer fluid.

You may use plain water as washer fluid. However, in cold area where temperatures range below the freezing point, use washer fluid containing antifreeze. This product is available at your Toyota dealer and most auto parts stores. Follow the manufacturer's directions for how much to mix with water. Do not use engine antifreeze or any other substitute because it may damage your vehicle's paint.

Replacing the wiper blades

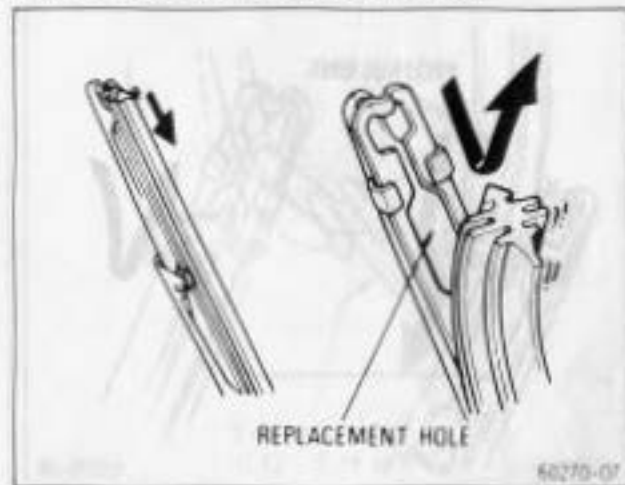

When the wipers no longer clean adequately, the wiper blades may be worn or cracked requiring replacement.

- Pull the top end of the rubber inward until the rubber blade is free of the end slot, and you can see the replacement hole.
- Pull the rubber blade out the replacement hole.

Checking blade depth with gage

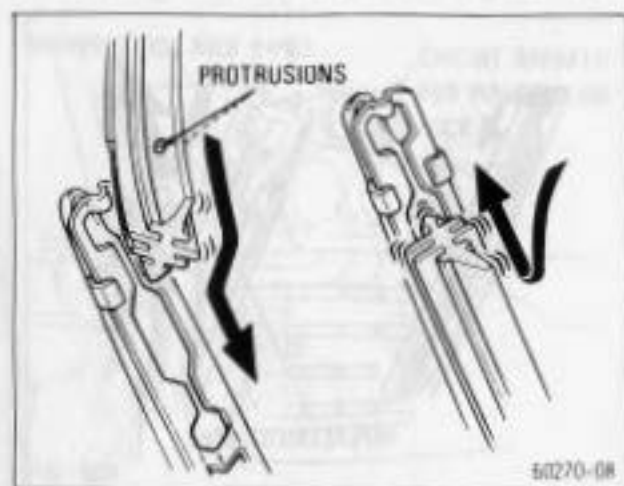

c. To install a new rubber, insert the end with small protrusions into the replacement hole, and work the rubber along the slot in the blade frame.

d. Once all of the rubber is in the frame slot, allow it to expand and fill in the end.

Checking manual transaxle oil

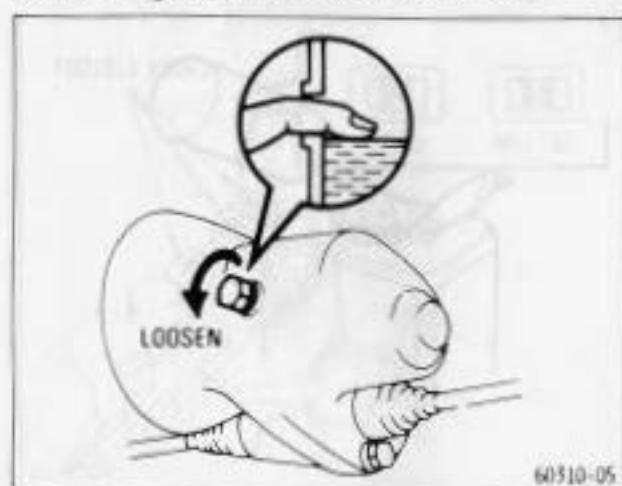

Remove the filler plug and feel inside the hole with your finger. The oil should come to the bottom edge of the hole. If the level is O.K., reinstall the plug and tighten it.

Right after driving the oil may be hot, so be careful.

- Make sure the vehicle is level while making this check.
- After installing the plug, visually check the transaxle case for leaks or damage.

Checking brake and clutch fluid

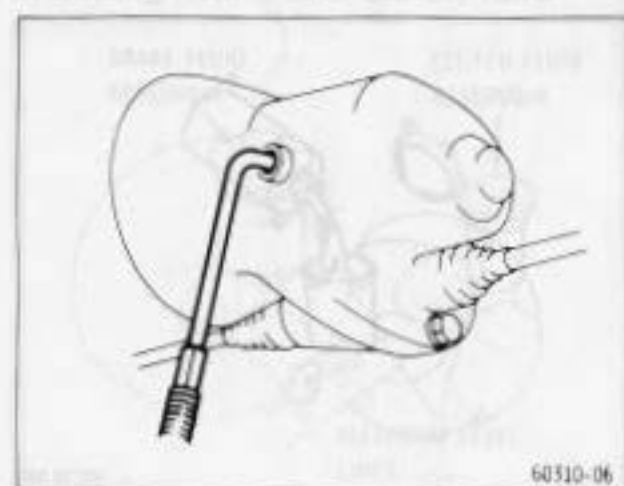

If the level is low, add multipurpose gear oil (API GL-4 or GL-5) until it begins to run out of the filler hole. Reinstall the plug securely.

Recommended viscosity:

SAE 75W-90 or 80W-90

- Fill the lubricant filler with gear oil.
- Put the end of the tube into the filler hole and add oil until it begins to run out.
- Install and tighten the filler plug.

Checking steering wheel freeplay

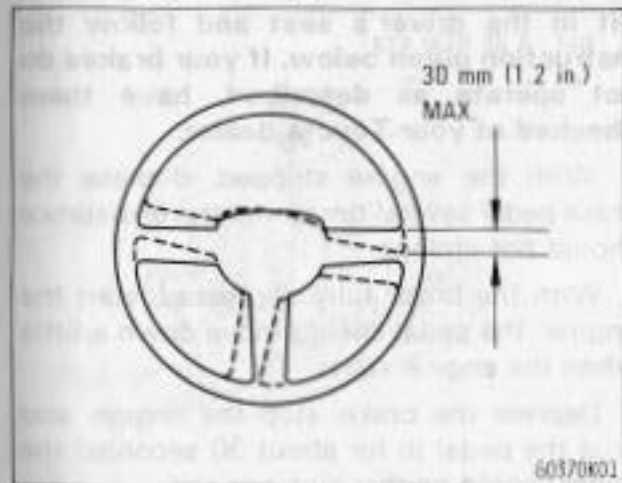

With the vehicle stopped and the front wheels pointed straight ahead, rock the steering wheel gently back and forth. If the freeplay is more than specified, have it inspected by your Toyota dealer.

Use only a very light finger pressure to rock the wheel slowly.

Checking clutch pedal freeplay

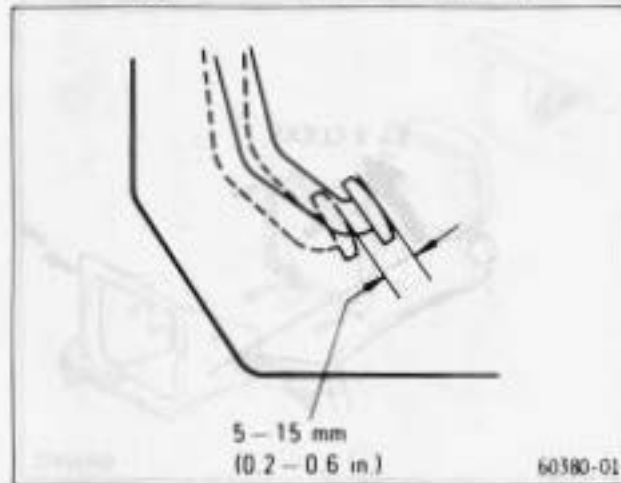

Press down lightly on the clutch pedal and measure the distance it moves freely before the clutch resistance is felt. The freeplay should be within the above limits.

If the freeplay is more or less, have your Toyota dealer inspect the clutch.

Checking brake pedal freeplay

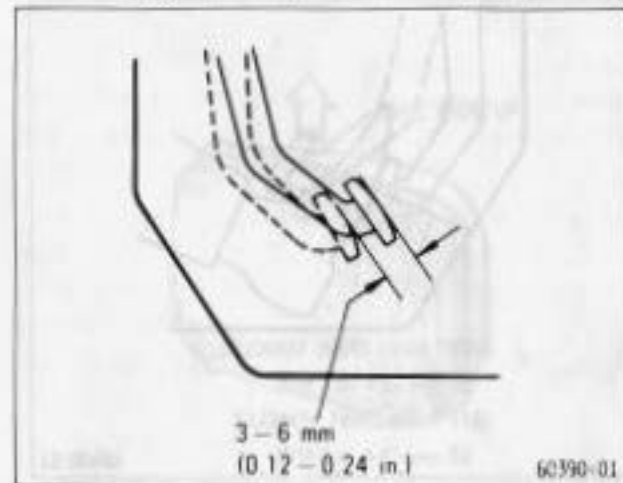

With the engine stopped, first reduce the vacuum in the booster by depressing the brake pedal several times. Then lightly and slowly press down on the pedal with your fingers and measure the distance it moves before slight resistance is felt.

If the freeplay is more or less than specification, have your Toyota dealer adjust the brakes.

Checking brake pedal clearance



With the engine running, have someone press the brake pedal several times and then press hard (approximately 50 kg [110 lb., 490 N]) on it. The distance from the asphalt sheet to the top surface of the pedal should not be less than specified.

If the clearance is less, have your Toyota dealer adjust the brakes.

Checking parking brake adjustment

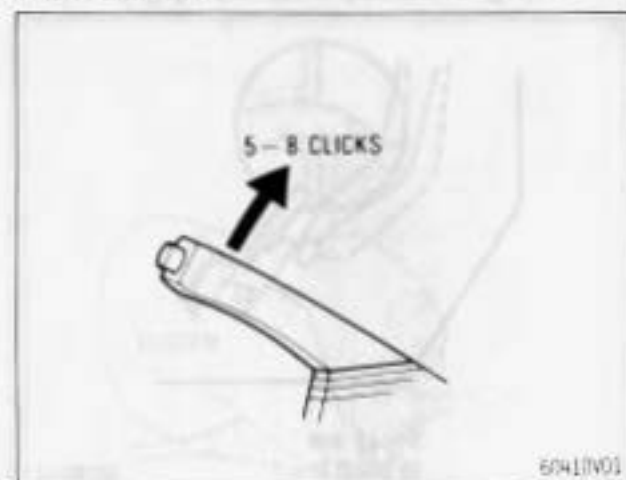

Count the number of clicks as you slowly pull on the parking brake as far as it will go. The adjustment is correct if you hear the number of clicks specified above.

If you count more or less clicks, have the parking brake adjusted by your Toyota dealer.

Checking the brake booster

Sit in the driver's seat and follow the instruction given below. If your brakes do not operate as described, have them checked at your Toyota dealer.

1. With the engine stopped, depress the brake pedal several times; the travel distance should not change.
2. With the brake fully depressed, start the engine; the pedal should move down a little when the engine starts.
3. Depress the brake, stop the engine, and hold the pedal in for about 30 seconds; the pedal should neither sink nor rise.
4. Restart the engine, run it for about a minute and turn it off. Then firmly depress the brake several times; the pedal travel should decrease with each application.

Replacing sealed beam headlight units

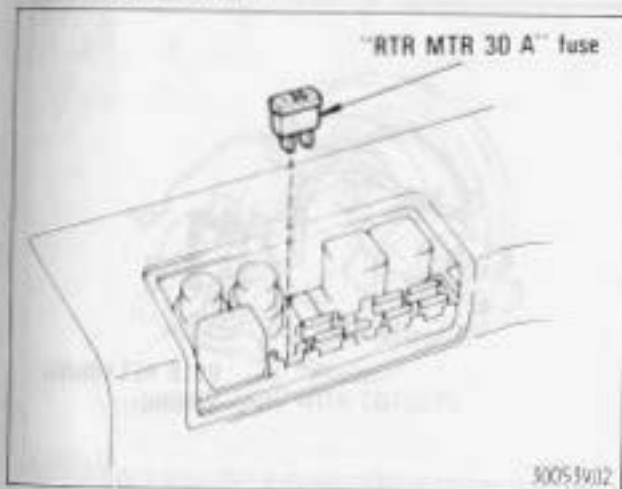

1. Push the headlight switch in and turn it to the third clickstop to raise the headlights. Then pull out the "RTR MTR 30 A" fuse.

Unless power is disconnected, there is danger of the headlights suddenly retracting and causing injury.

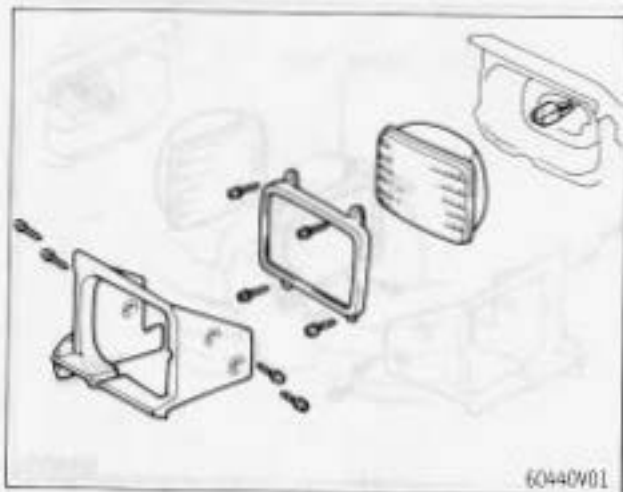

2. Remove the ornament and the beam unit retaining ring screws, take out the beam unit and disconnect the wire connector. To install a new sealed beam, follow the removal procedure in reverse order.

Never attempt to loosen the headlight aim adjusting screws.

If the wire connector is tight, wiggle it.

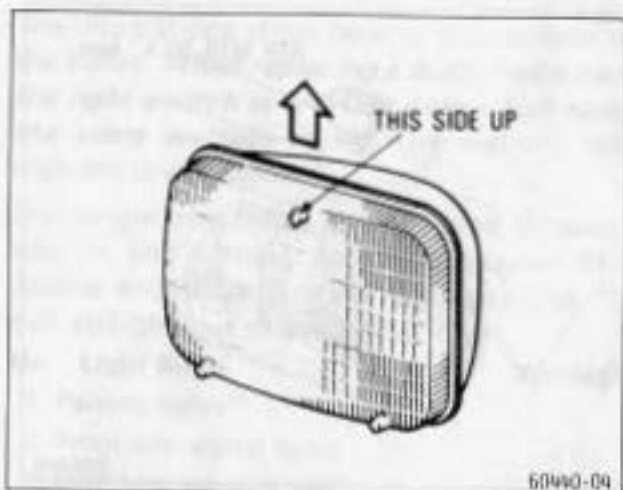

Use only a beam unit with the same wattage.

Wattage: 65/35

Install the beam unit with the single protrusion on the glass face up and be sure to connect the wire connector.

Do not forget to reinstall the fuse. After replacing a beam unit, have the headlight aim checked by your Toyota dealer.

Replacing semi-sealed beam headlight bulbs

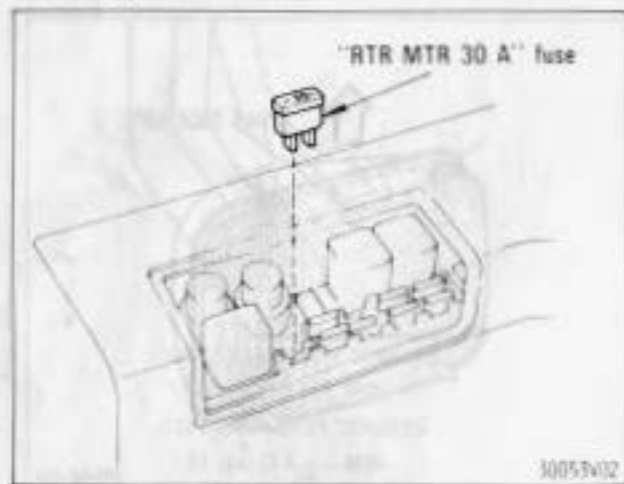

1. Push the headlight switch in and turn it to the third clickstop to raise the headlights. Then pull out the "RTR MTR 30 A" fuse.

Unless power is disconnected, there is danger of the headlights suddenly retracting and causing injury.

Checking parking brake adjustment

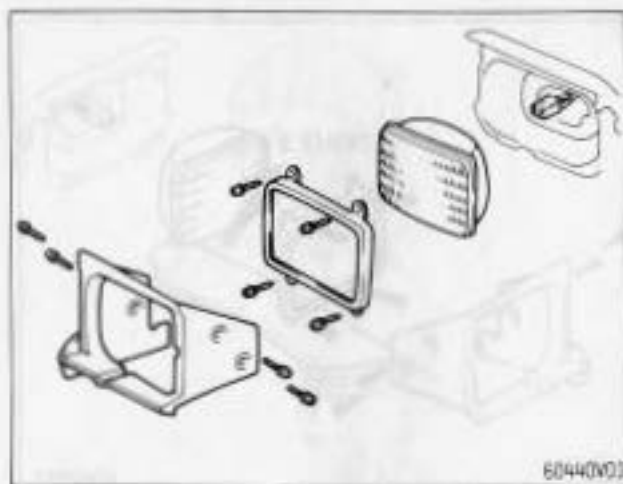

2. Remove the ornament and the beam unit retaining ring screws, take out the beam unit and disconnect the wire connector.

Never attempt to loosen the headlight aim adjusting screws.

If the wire connector is tight, wiggle it.

Checking the brake

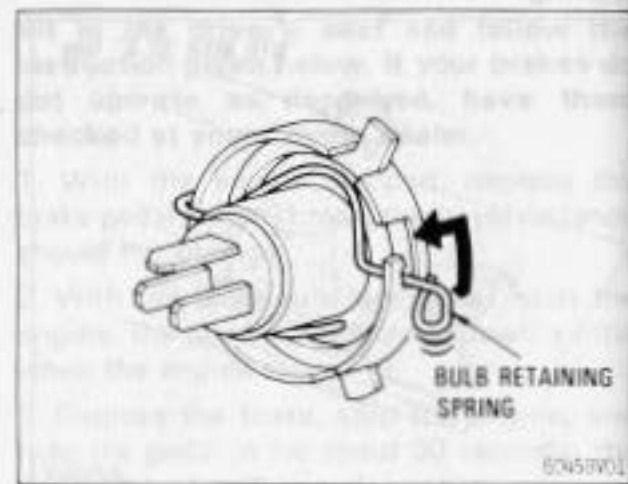

3. Remove the rubber cover, release the bulb retaining spring and remove the bulb.

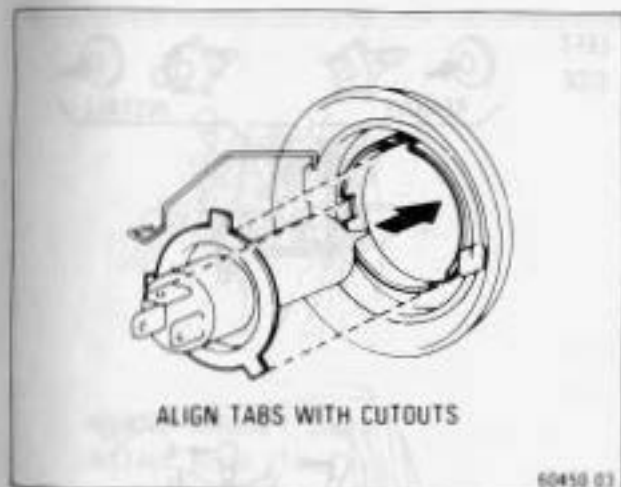

4. Install a new bulb and the bulb retaining spring.

To install a bulb, align the tabs of the bulb socket with the cutouts of the headlight body.

Use only a bulb with the same wattage.

Wattage: 60/55 (H4)

Do not touch the glass part of the bulb with bare hands. If you do, clean the glass with alcohol and a clean rag.

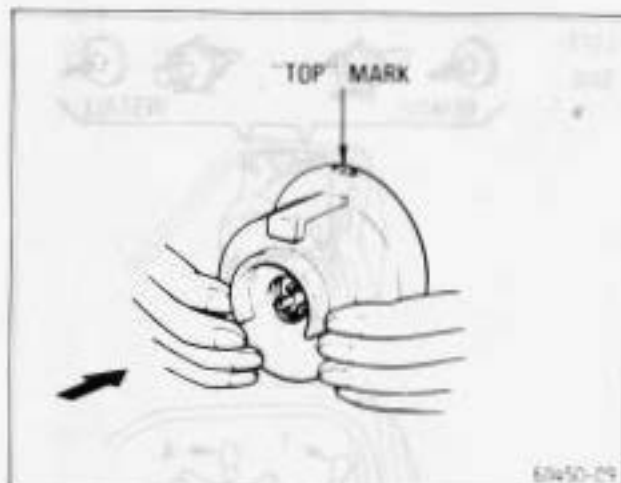

5. Install the rubber cover with the "TOP" mark upward, and snuggle on the boss. Connect the wire connector. To install the beam unit, follow the removal procedure in reverse order.

Make sure the rubber cover fits snugly on the wire connector and the headlight body.

After replacement, have the headlight aim checked by your Toyota dealer.

Replacing light bulbs

The illustrations show how to gain access to the bulbs. *When replacing a bulb, make sure the light switch is off. Use only a bulb with the same wattage rating.* The wattage ratings are given below.

The single end bulbs are removed by pressing in and turning counterclockwise. The double-end bulbs (*) or wedge base bulbs (**) pull straight out of the holder clips.

No.	Light Bulbs	Wattage
1	Parking lights**	5
2	Front turn signal lights	21
3	Side turn signal lights**	5
4	Rear turn signal lights	21
5	Stop and tail lights	21/5
6	Rear fog lights	21
7	Back-up lights	21
8	License plate lights	
	Australia	7.5
	Others	10
9	Interior light*	10

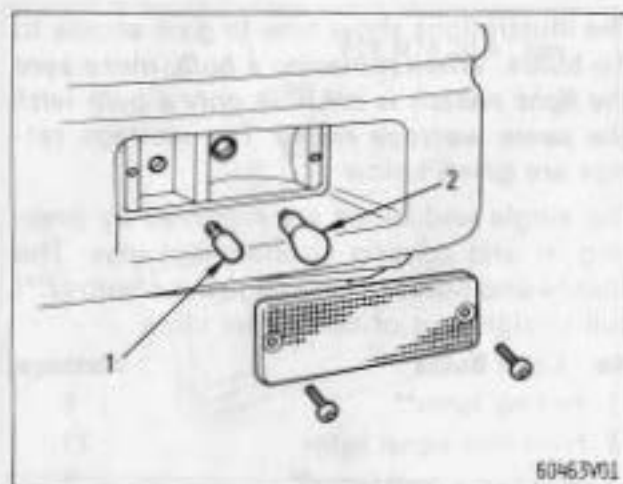

Front turn signal and parking lights

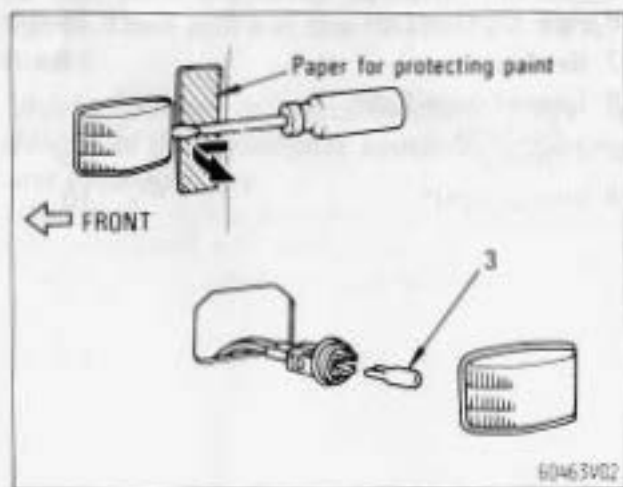

Side turn signal lights

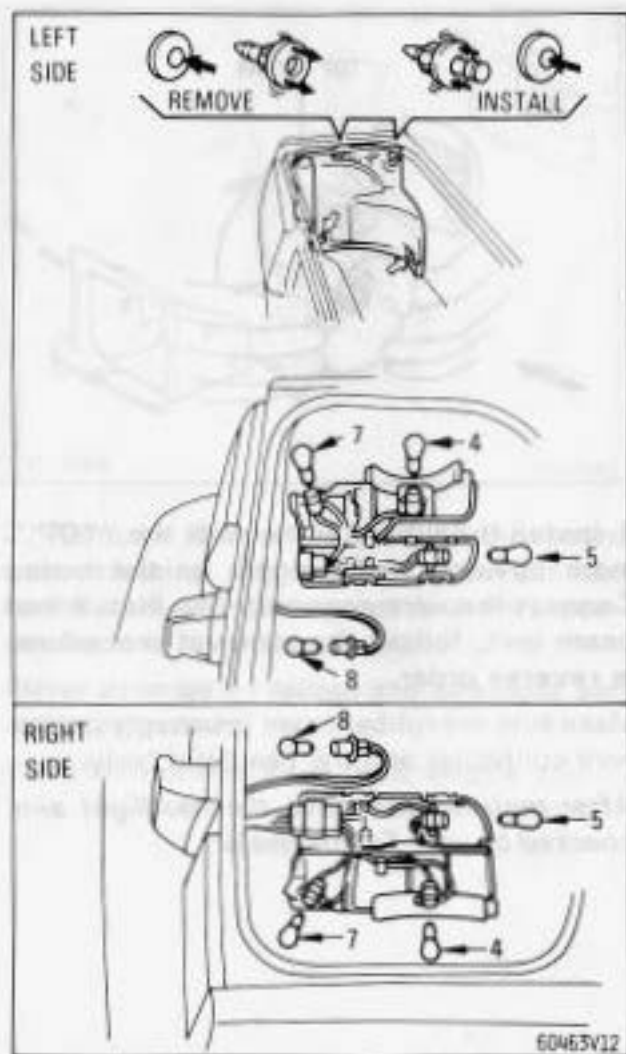

EXCEPT EUROPE: Rear turn signal, stop and tail, back-up and license plate lights

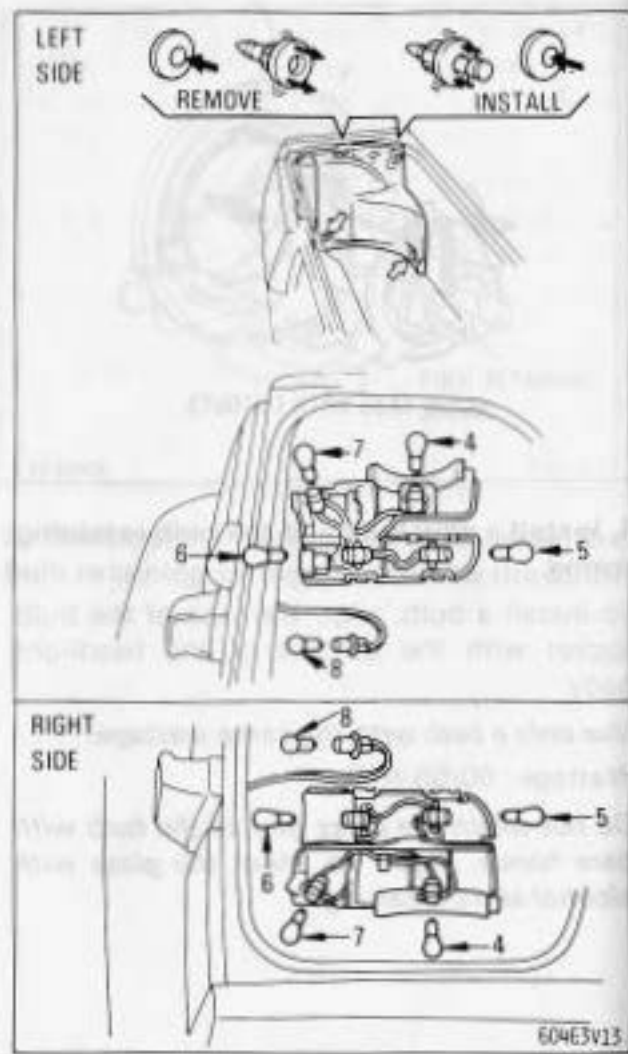

EUROPE: Rear turn signal, stop and tail, rear fog, back-up and license plate lights

Your Toyota's identification

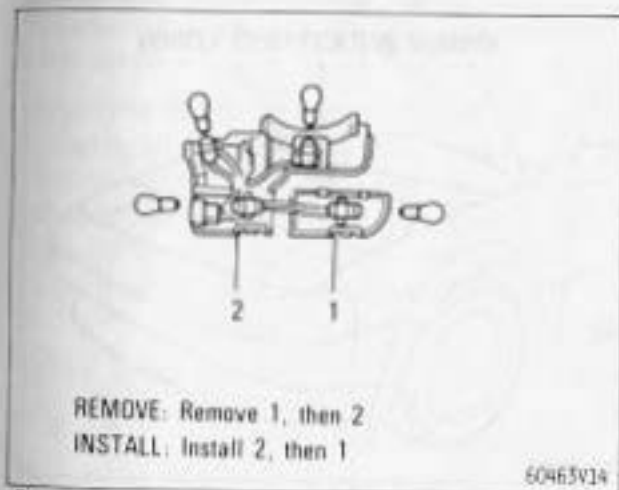

Removing and installing of the light cover

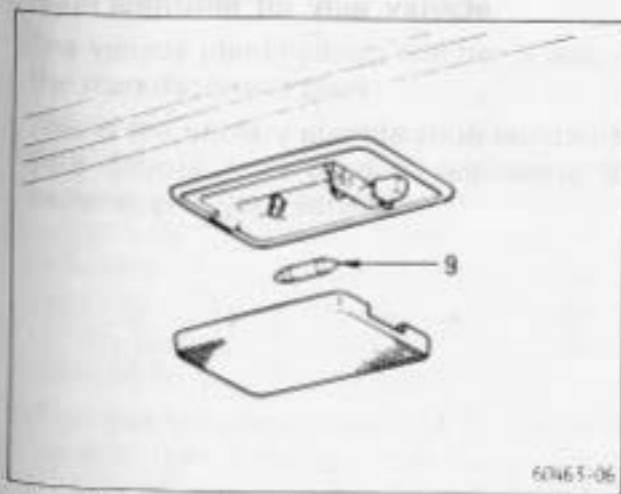

Interior light



The above number is identified in the illustration as shown.



1. Place the lid on the container.

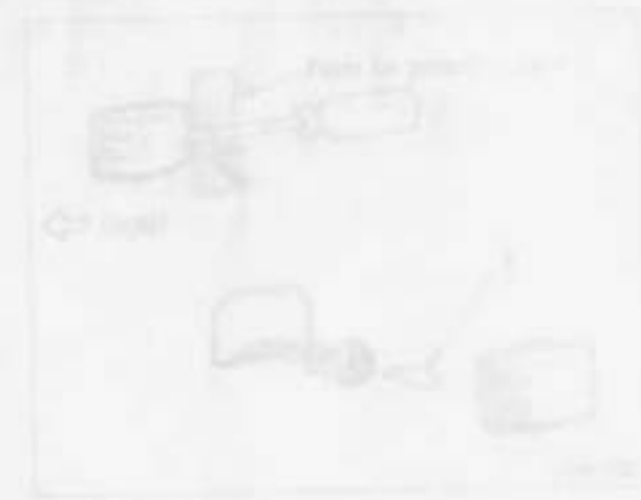

2. Lift the lid off the container.



3. Place the lid on the container and lock it.



4. Place the lid on the container and lock it.

Your Toyota's identification

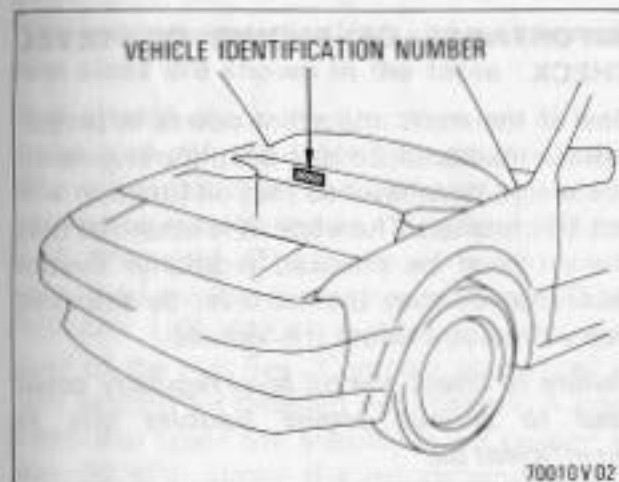

The vehicle identification number is the legal identifier for your vehicle.

The vehicle identification number is also on the manufacturer's plate.

This is the primary identification number for your Toyota. It is used in registering the ownership of your vehicle.

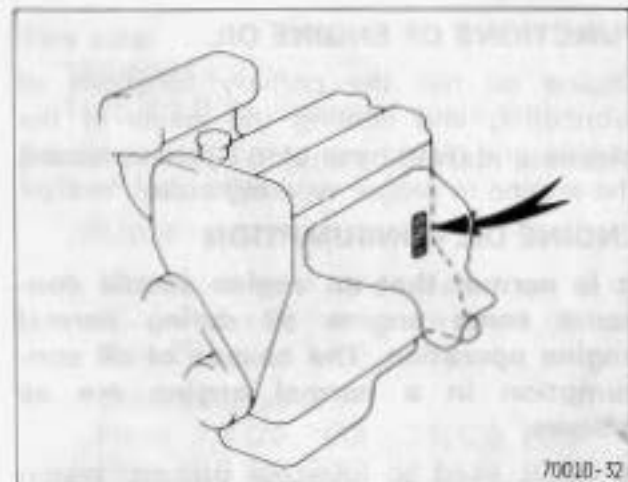
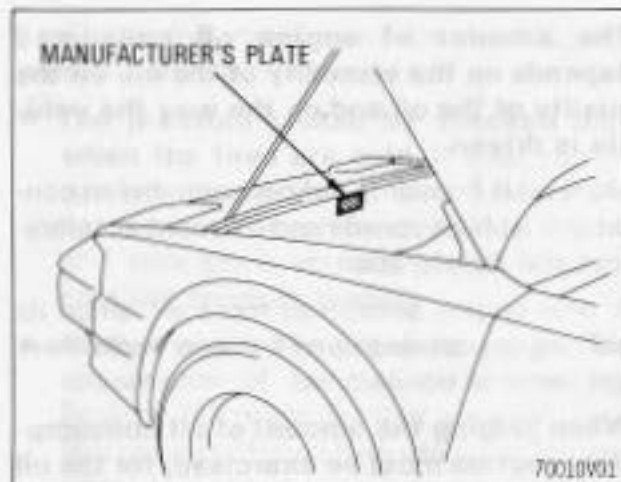

The engine number is stamped on the engine block as shown.

Facts about engine oil consumption

FUNCTIONS OF ENGINE OIL

Engine oil has the primary functions of lubricating and cooling the inside of the engine, and plays a major role in maintaining the engine in proper working order.

ENGINE OIL CONSUMPTION

It is normal that an engine should consume some engine oil during normal engine operation. The causes of oil consumption in a normal engine are as follows.

- Oil is used to lubricate pistons, piston rings and cylinders. A thin film of oil is left on the cylinder wall when a piston moves downwards in the cylinder. High negative pressure generated when the vehicle is decelerating sucks some of this oil into the combustion chamber. This oil as well as some part of the oil film left on the cylinder wall is burned by the high temperature combustion gases during the combustion process.
- Oil is also used to lubricate the stems of the intake valves. Some of this oil is sucked into the combustion chamber together with the intake air and is burned along with the fuel. High temperature exhaust gases also burn the oil used to lubricate the exhaust valve stems.

The amount of engine oil consumed depends on the viscosity of the oil, on the quality of the oil and on the way the vehicle is driven.

More oil is consumed under such driven conditions as high speeds and frequent acceleration and deceleration.

A new engine consumes more oil, since its pistons, piston rings and cylinder walls have not become conditioned.

When judging the amount of oil consumption, caution must be exercised, for the oil may become diluted and make it difficult to judge the true level accurately.

As an example, if a vehicle is used for repeated short trips, and consumes a normal amount of oil, the dipstick may not show any drop in the oil level at all, even after 1000 km (600 miles) or more. This is because the oil is gradually becoming diluted with fuel or moisture, making it appear that the oil level has not changed.

The diluting ingredients evaporate out when the vehicle is then driven at high speeds, as on an expressway, making it appear that oil is excessively consumed after driving at high speeds.

IMPORTANCE OF ENGINE OIL LEVEL CHECK

One of the most important points in proper vehicle maintenance is to keep the engine oil at the optimum level so that oil function will not be impaired. Therefore, it is essential that the oil level be checked regularly. Toyota recommends that the oil level be checked every time you refuel the vehicle.

Failure to check the oil level regularly could lead to serious engine troubles due to insufficient oil.

For detailed information on oil level check, see "Checking the engine oil level" in Section 6.

Tire information —

The recommended cold tire pressures and tire sizes are shown in the table.

You should check the tire pressures at least once a month. And don't forget the spare! The air pressure of the compact spare tire should be maintained at 4.2 kg/cm² (60 psi, 410 kPa) cold. (The compact spare tire is identified by the distinctive wording "TEMPORARY USE ONLY" molded into the side wall of the tire. See "Compact spare tire" in this section for detailed information.) A conventional spare tire should be 0.3 kg/cm² (4 psi, 30 kPa) above the recommended cold tire pressure. Incorrect tire pressure can reduce tire life and make your vehicle less safe to drive.

Low tire pressure results in excessive wear, poor handling, reduced fuel economy, and the possibility of blowouts from overheated tires. Also, low tire pressure can cause poor sealing of the tire bead. If the tire pressure is excessively low, there is the possibility of wheel deformation and/or tire separation. So keep your tire pressures at the proper level. If a tire frequently needs refilling, have it checked by your Toyota dealer.

High tire pressure produces a harsh ride, handling problems, excessive wear at the center of the tire tread, and a greater possibility of tire damage from road hazards.

The following instructions for checking tire pressure should be observed:

- **The pressure should be checked only when the tires are cold.** If your vehicle has been parked for at least 3 hours and has not been driven for more than 1.5 km or 1 mile since, you will get an accurate cold tire pressure reading.
- **Always use a tire pressure gauge.** The appearance of tire can be misleading. Besides, tire pressures that are even just a few pounds off can degrade handling and ride.
- **Do not bleed or reduce tire pressure after driving.** It is normal for the tire pressure to be higher after driving.
- **Be sure to reinstall the tire inflation valve caps.** Without the valve caps, dirt or moisture could get into the valve core and cause air leakage. If the caps have been lost, have new ones put on as soon as possible.

Tire size:

185/60R14 82H
T125/70 D 14 (compact spare tire)

Recommended cold tire inflation pressure kg/cm² (psi, kPa):

185/60R14 82H

- With front trunk load of less than 10 kg (22.1 lb.) and rear trunk load of less than 20 kg (44.1 lb.)

Except Australia

Front	1.8 (26, 180)	2.0 (28, 200)*
Rear	2.0 (28, 200)	2.2 (31, 220)*

*: High speeds over 160 km/h (100 mph)

Australia

Front	1.8 (26, 180)	2.4 (34, 240)**
Rear	2.0 (28, 200)	2.6 (37, 260)**

** : High speeds over 140 km/h (87 mph)

- With front trunk load of 10 kg (22.1 lb.) or more and rear trunk load of 20 kg (44.1 lb.) or more

Front	2.4 (34, 240)
Rear	2.6 (37, 260)

T125/70 D 14
4.2 (60, 410)

Tire rotation

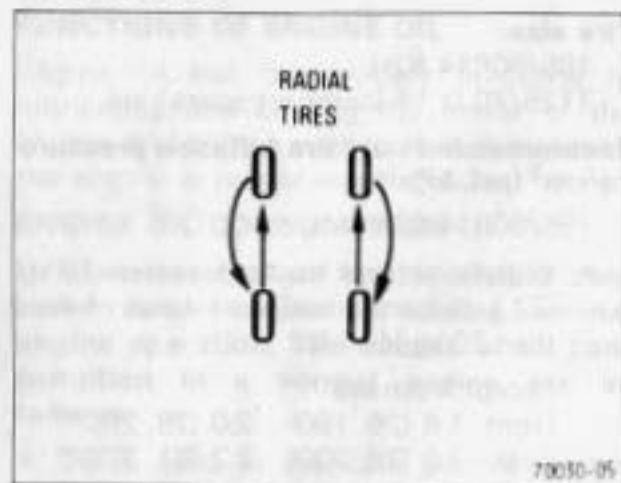

To equalize the wear of your tires, rotate the tires every 10000 km (6000 miles).

Do not include a compact spare tire when rotating the tires. It is designed for temporary use only.

When rotating tires, check for uneven wear and damage. Abnormal wear is usually caused by incorrect tire pressure, improper wheel alignment, out-of-balance wheels, or severe braking.

After rotation, be sure to bring the front and rear tire pressures to specification and check wheel nut tightness.

The placement of tires on your vehicle will depend on the manufacturer's recommendations. Always use the correct tire size and load rating. The correct tire size and load rating are listed on the tire placard. The tire placard is located in the driver's door jamb. The tire placard also lists the correct tire pressure. The correct tire pressure is listed in the owner's manual. The correct tire pressure is also listed on the tire placard. The correct tire pressure is also listed on the tire placard.

Before storing radial, snow or studded tires, mark the direction of rotation and be sure to install them in the same direction when replacing. Tires should be stored in a cool dry place.

When storing tires, mark the direction of rotation and be sure to install them in the same direction when replacing. Tires should be stored in a cool dry place.

The effectiveness of snow and studded tires is lost if the tread wears down below 4 mm (0.16 in.).

Changing tires and wheels

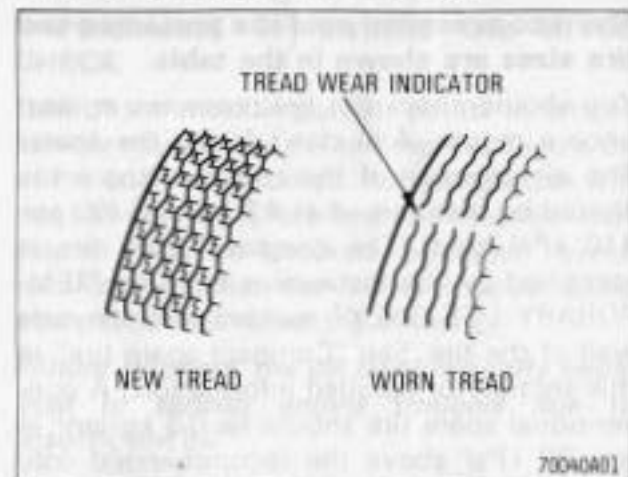

Replace the tires when the tread wear indicators show.

The tires on your Toyota have built-in tread wear indicators to help you know when the tires need replacement. When the tread depth wears to 1.6 mm (0.06 in.) or less, the indicators will appear. If you can see the indicators in two or more adjacent grooves, the tire should be replaced.

The effectiveness of snow and studded tires is lost if the tread wears down below 4 mm (0.16 in.).

Compact spare tire

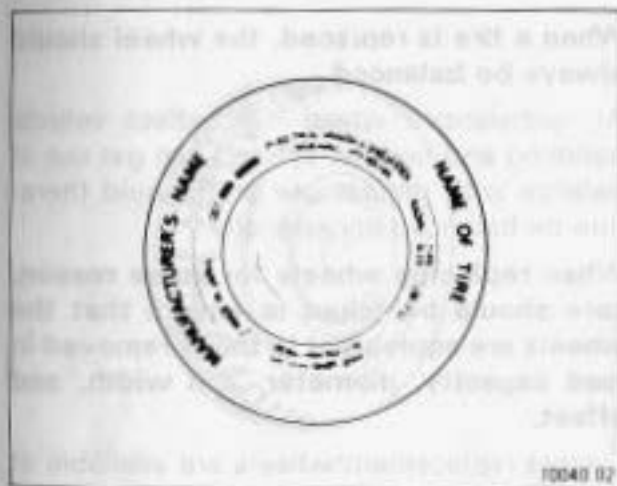

When replacing a tire, use only the same size and construction as originally installed and with the same or greater load capacity.

Using any other size or type of tire may seriously affect handling, ride, speedometer/odometer calibration, ground clearance, and clearance between the body and tires or snow chains.

When replacing a tubeless tire, the air valve should also be replaced with a new one.

Do not mix radial, belted, or conventional tires on your vehicle.

It can cause dangerous handling characteristics, resulting in loss of control. If you want to change from conventional tires to radial tires or vice versa, replace them as a set. However, if you use a compact spare tire, do not include it.

If you want to replace a tire, we recommend that you replace all four tires at once.

However, if you need to replace only two tires, mount the new tires on the front wheels for better stability.

If you need to replace only one tire, mount the new tire to the axle with the tire showing the least amount of wear.

Be careful in preventing tires from coming into contact with oil or gasoline.

If you have tire damage such as cuts, splits, cracks deep enough to expose the fabric, and bulges indicating internal damage, the tire should be replaced.

If a tire often goes flat or cannot be properly repaired due to the size or location of a cut or other damage, it should be replaced. If you are not sure, consult with a technician.

If an air loss occurs while driving, do not continue driving with a deflated tire. Driving even a short distance can damage a tire beyond repair.

If you have used an aerosol-type sealant for a temporary repair, a permanent vulcanized repair should be made as soon as possible.

Do not drive more than 160 km (100 miles) and over 80 km/h (50 mph) with a temporary repair.

If you need snow tires, select snow tires of the same size, construction and load capacity corresponding to the original tires on your Toyota. Snow tires should be installed on all wheels.

Installing snow tires only on the rear wheels will affect broadside road grip capability between the front and rear tires and vehicle stability under all road conditions, especially on dry roads, and may cause loss of vehicle control.

Snow tires should be inflated to 0.3 kg/cm² (4 psi, 30 kPa) above the normal cold tire recommendations, but never above the maximum cold tire pressure of 2.25 kg/cm² (32 psi, 220 kPa). *Observe permissible maximum speed for your snow tires and the legal speed limit. If your vehicle has radial tires as original equipment, make sure your snow tires also have radial construction.* Do not install studded tires without first checking local regulations for possible restrictions.

Tire rotation

On wet or dry roads, conventional or radial tires provide better traction than snow or studded tires. However, snow tires or chains are recommended when driving on snow or ice to avoid high-fuel consumption caused by spinning wheels.

Avoid sharp turns or locked-wheel braking as use of chains may adversely affect vehicle handling.

Regulations regarding the use of tire chains vary according to location or type of road, so always check them before installing chains.

To prevent chain damage to your vehicle:

1. The chain band will scratch the wheel covers so remove the covers, if equipped, before putting on the chains.
2. Install the chains on the rear tires as tightly as possible. Do not use tire chains on the front tires. Retighten chains after driving 0.5–1.0 km (1/4–1/2 mile).
3. Do not exceed 50 km/h (30 mph) or the chain manufacturer's recommended speed limit, whichever is lower.
4. Drive carefully avoiding bumps, holes, and sharp turns, which may cause the vehicle to bounce.
5. Follow the instructions of the chain manufacturer.

If you need to replace the tires due to wear or damage, the following precautions should be observed when mounting the tire on the wheel.

- Lubricate wheel and tire beads with soapy water or tire mounting lubricant.
- To properly seat the tire on the rim, inflate the tire to a maximum of 3.5–4.0 kg/cm² (50–56 psi, 340–390 kPa).
- Adjust inflation to the recommended pressure.

If you have wheel damage such as bends, cracks or heavy corrosion, the wheel should be replaced.

If you fail to replace damaged wheels, the tire may slip off the wheel or they may cause loss of handling control.

Replacement with used wheels is not recommended as they may have been subjected to rough treatment or high mileage and could fail without warning. Also, bent wheels which have been straightened may have structural damage and therefore should not be used. Never use an inner tube in a leaking wheel which is designed for a tubeless tire.

Changing tires and wheels

When a tire is replaced, the wheel should always be balanced.

An unbalanced wheel may affect vehicle handling and tire life. Wheels can get out of balance with regular use and should therefore be balanced occasionally.

When replacing wheels for some reason, care should be taken to ensure that the wheels are equivalent to those removed in load capacity, diameter, rim width, and offset.

Correct replacement wheels are available at your Toyota dealer.

A wheel of a different size or type may adversely affect handling, wheel and bearing life, brake cooling, speedometer/odometer calibration, stopping ability, headlight aim, bumper height, vehicle ground clearance, and tire or snow chain clearance to the body and chassis.

Compact spare tire

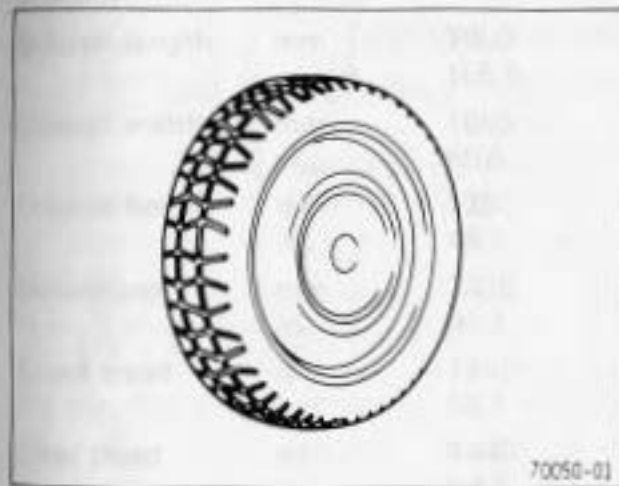

70050-01

The compact spare tire saves space in your front trunk room, and its lighter weight helps to improve fuel economy and permits easier installation in case of a flat tire.

- The compact spare tire is designed for **temporary use only**. The standard tire should be repaired and replaced as soon as possible.
- The compact spare tire was designed especially for your Toyota—do not use it on any other vehicle.

Engine and suspension load by minimum



70050-02

- The compact spare tire can be used many times, if necessary. It has tread life of up to 4800 km (3000 miles) depending on road conditions and your driving habits. When tread wear indicators appear on the tire, replace the tire. To conserve the tread life of the compact spare tire, the standard tire should be repaired and replaced as soon as possible.
- Do not use the compact spare tire with any other rim. Nor should standard tires, wheel covers, or trim rings be used on the compact spare tire rim as such may cause damage to these items or other vehicle components.

Fuel



70050-03

- Check the air pressure of your compact spare tire at least once a month, and maintain a cold tire pressure of 4.2 kg/cm² (60 psi, 410 kPa). When adding air to the compact spare tire you must be very careful, since the smaller tire size can gain pressure very quickly. Add compressed air in small quantities and check the pressure often until it reached 4.2 kg/cm² (60 psi, 410 kPa) at cold.
 - Do not attempt to use a tire chain on the compact spare tire, as it may result in damage to the vehicle as well as the tire.
- When driving with the compact spare tire, keep the following in mind.

- Do not exceed 80 km/h (50 mph).

- Because the compact spare tire is smaller than the standard tire, vehicle ground clearance is reduced when the compact spare tire is installed. Therefore, avoid driving over obstacles and do not take your vehicle through an automatic car wash with the compact spare tire installed as the vehicle may get caught resulting in property damage.

If you need to replace the compact spare tire due to wear or damage, be sure the installer observes the following precautions when mounting the tire on the wheel.

- Lubricate the wheel and tire beads with tire mounting lubricant.
- Mount the tire to the wheel and inflate the tire up to 2.8 kg/cm^2 (40 psi, 270 kPa).
- Check to see that the tire is properly seated on the rim.
- If the tire is properly seated, inflate the tire to 4.2 kg/cm^2 (60 psi, 410 kPa) cold. If not properly seated, deflate, separate the tire bead from the rim, reinflate up to 2.8 kg/cm^2 (40 psi, 270 kPa) and repeat the procedure above.

Aluminum wheel precautions

- After driving your vehicle the first 1600 km (1000 miles), check that the wheel nuts are tight.
- If you have rotated, repaired, or changed your tires, check that the wheel nuts are still tight after driving 1600 km (1000 miles).
- When using tire chains, be careful not to damage the aluminum wheels.
- Use only the Toyota wheel nuts designed for your aluminum wheels.
- When balancing your wheels, use only Toyota balance weights or equivalent and a plastic or rubber hammer.
- As with any wheel, periodically check your aluminum wheels for damage. If damaged, replace immediately.



Specifications—Section 8

Dimensions

Overall length	mm	3950
	in.	155.5
Overall width	mm	1665
	in.	65.6
Overall height	mm	1250
	in.	49.2
Wheelbase	mm	2320
	in.	91.3
Front tread	mm	1440
	in.	56.7
Rear tread	mm	1440
	in.	56.7

Engine

Model: 4A-GE
Type:
4 cylinder in line, 4 cycle, gasoline
Bore and stroke, mm (in.):
81.0 x 77.0 (3.19 x 3.03)
Displacement, cc (cu. in.):
1587 (96.8)



Fuel

Fuel required:

Vehicles with catalytic converter:
Unleaded gasoline with the following octane number or higher (Research Octane Number)

Europe	95
Others	91

Vehicles without catalytic converter:
Gasoline, leaded or unleaded, with the following octane number or higher (Research Octane Number)

Europe	95
Others	94

Fuel tank capacity, liter (Imp. gal.):
41 (9.0)



Service specifications

ENGINE

Valve clearance (engine cold), mm (in.):

Intake	0.15 - 0.25 (0.006 - 0.010)
Exhaust	0.20 - 0.30 (0.008 - 0.012)

Spark plug gap, mm (in.): 1.1 (0.043)

Drive belt deflection with 10 kg (22 lb., 98 N) thumb pressure, mm (in.):

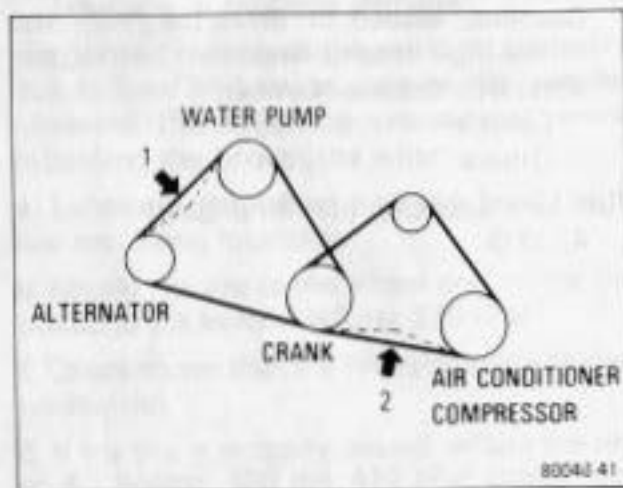

1. 6.0 - 7.0 (0.24 - 0.28)

2. 7.7 - 8.6 (0.30 - 0.34)

Ignition timing:

10° BTDC @ max. 800 rpm

(at short-circuiting the terminal T)

ENGINE LUBRICATION

Oil capacity, liter (Imp. qt.):

Dry fill	3.8 (3.3)
Drain and refill	
with filter	3.4 (3.0)
without filter	3.1 (2.7)

Oil grade (API):

Europe and Australia

SE, SF or better

Others

SD, SE, SF or better

Recommended oil viscosity (SAE):

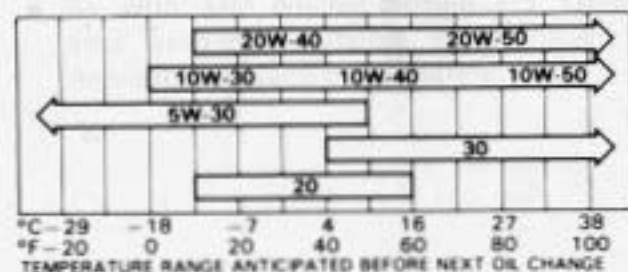

COOLING SYSTEM

Total capacity, liter (Imp. qt.): 12.4 (10.9)

Coolant type:

Ethylene-glycol or alcohol

(Ethylene-glycol type recommended)

BATTERY

Specific gravity reading at 20°C (68°F):

1.260	Fully charged
1.160	Half charged
1.060	Discharged

Charging rates:

Quick charge	15 A max.
Slow charge	5 A max.

CLUTCH

Pedal freeplay, mm (in.):

5 - 15 (0.2 - 0.6)

Fluid type: DOT 3 or SAE J1703

MANUAL TRANSAXLE

Oil capacity, liter (Imp. qt.): 2.6 (2.3)

Oil type: Multipurpose gear oil API GL-4 or GL-5

Recommended oil viscosity:

SAE 75W-90 or 80W-90

BRAKES

Minimum pedal clearance when depressed, mm (in.):

Right-hand drive vehicles

80 (3.1)

Left-hand drive vehicles

87 (3.4)

Pedal freeplay, mm (in.):

3–6 (0.12–0.24)

Parking brake adjustment: 5–8 clicks

Fluid type: DOT 3 or SAE J1703

STEERING

Wheel freeplay:

Less than 30 mm (1.2 in.)

Fuses and circuit breaker

DRIVER'S SIDE KICK PANEL

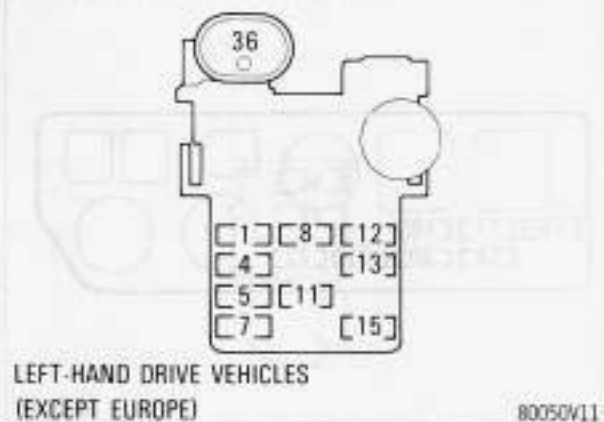

Fuses

- 1. TURN GAG 7.5 A:** Cruise control system, econodrive monitor, engine temperature gauge, fuel gauge, tachometer, turn signal lights, voltmeter, warning lights
- 2. GAUGE 7.5 A:** Cruise control system, econodrive monitor, engine temperature gauge, fuel gauge, tachometer, voltmeter, warning lights
- 3. TURN 7.5 A:** Turn signal lights
- 4. WIPER 20 A:** Windshield wipers and washer
- 5. DOOR 30 A:** Power window

DRIVER'S SIDE KICK PANEL

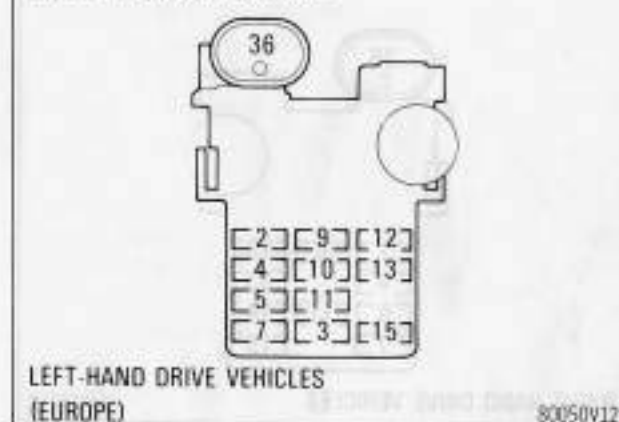

- 6. P.W 30 A:** Power window
- 7. RAD CIG 15 A:** Cigarette lighter, power rear view mirror, radio, stereo cassette tape player
- 8. TAIL 15 A:** Instrument panel lights, license plate lights, parking lights, tail lights
- 9. TAIL (RH) 10 A:** Instrument panel lights, right-hand parking light, right-hand tail light, right-hand license plate light
- 10. TAIL (LH) 10 A:** Left-hand parking light, left-hand tail light, left-hand license plate light

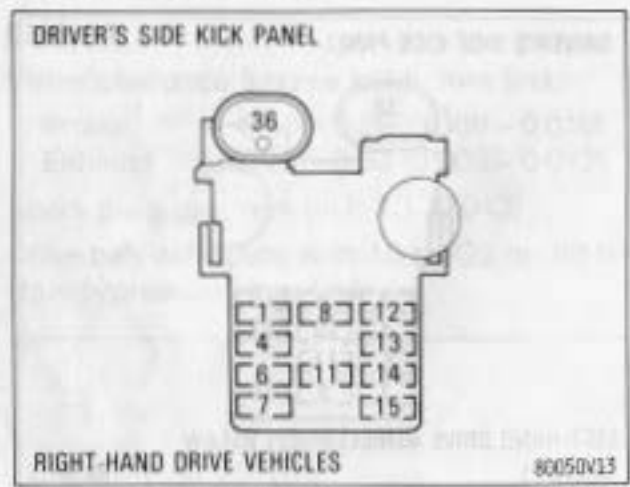

- 11. **DEFOG 20 A:** Rear window defogger
- 12. **DOME 7.5 A:** Clock, interior light, rear fog lights
- 13. **STOP 10 A:** Stop lights
- 14. **FOG 15 A:** No circuit
- 15. **FAN-I/UP 7.5 A:** Radiator cooling fan

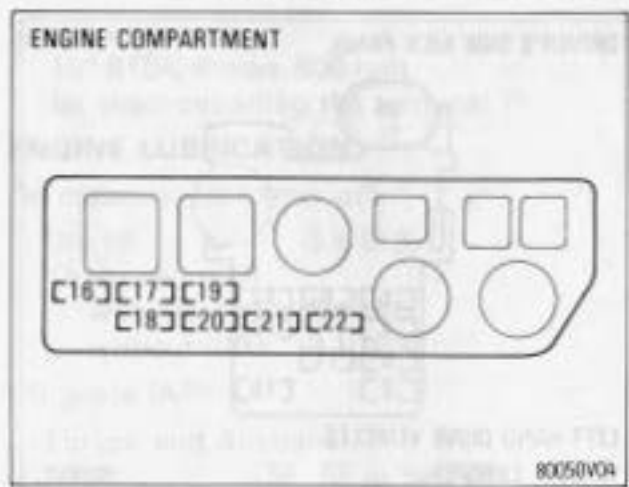

- 16. **VENT FAN 20 A:** Engine cooling fan
- 17. **AM2 7.5 A:** No circuit
- 18. **HAZ-RADIO 15 A:** Emergency flashers
- 19. **INJ 10 A*:** Electronic fuel injection control system (EFI)
- *: Vehicles without catalytic converter only
- 20. **EFI 15 A:** Electronic fuel injection control system (EFI)
- 21. **ENGINE 10 A:** Alternator with IC regulator (IG terminal), back-up lights
- 22. **CHARGE 5 A:** Alternator with IC regulator (L terminal)

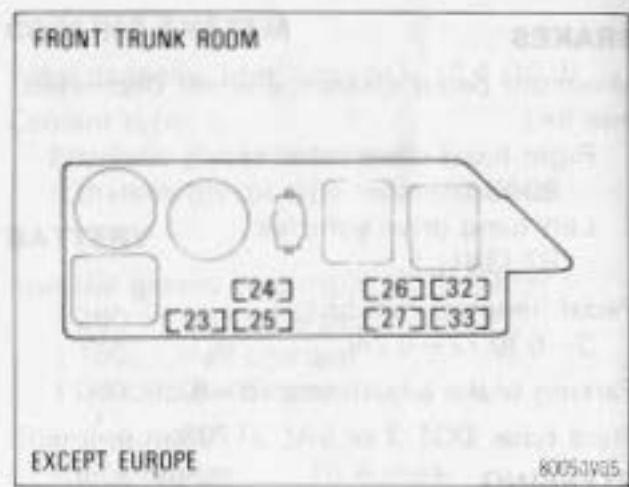

- 23. **RTR MTR 30 A:** Retractable headlight system
- 24. **HORN 10 A:** Horn
- 25. **RTR 7.5 A:** Retractable headlight system
- 26. **HEAD (LH) 15 A:** Left-hand headlight
- 27. **HEAD (RH) 15 A:** Right-hand headlight
- 28. **HEAD (LH-LWR) 10 A:** Left-hand headlight (low beam)
- 29. **HEAD (RH-LWR) 10 A:** Right-hand headlight (low beam), rear fog lights



- 11. 02 FEB 20 A
- 12. 00 16 28 A
- 13. 01 09 10 A
- 14. 00 18 18 A
- 15. 00 10 17 18 A



- 16. 00 10 17 18 A
- 17. 00 18 18 A
- 18. 00 18 18 A
- 19. 00 18 18 A
- 20. 00 18 18 A
- 21. 00 18 18 A
- 22. 00 18 18 A

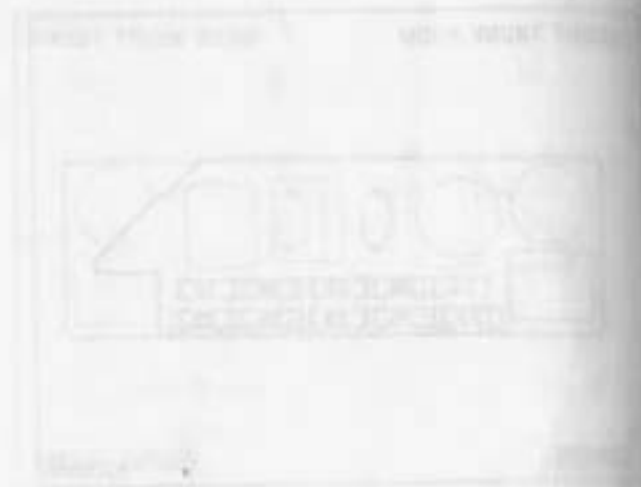

- 23. 00 18 18 A
- 24. 00 18 18 A
- 25. 00 18 18 A
- 26. 00 18 18 A
- 27. 00 18 18 A
- 28. 00 18 18 A
- 29. 00 18 18 A

Index—Section 9

A

Adding washer fluid	105
Adjustment	
Driver's seat lumbar support	7
Front seat cushion angle	6
Front seat position	5
Front seatback angle	5
Seat belt	7
Air cleaner	96
Air conditioner	23
Aluminum wheel precautions	122
Anti-theft steering column lock	11
Appearance care	
Cleaning the interior	75
Protecting your Toyota from corrosion	73
Washing and waxing	74
Automatic air conditioner	24
Auxiliary catch, Engine hood	48

B

Battery	
Checking battery condition and fluid level	100
Emergency starting	61
Fluid level	100
Gas caution	100
Handling safety	100
Recharging precautions	101
Winter driving tips	59
Before starting the engine	51
Belts	
Engine drive	96
Brake pad wear indicators	16

Brake system warning light	15
Brakes	
Booster	108
Braking tips	54
Fluid level	104
Pad wear indicators	16
Parking	38
Parking brake adjustment	108
Parking brake reminder light	38
Pedal clearance	108
Pedal freeplay	107
Pedal travel	108
Braking tips	54
Break-in tips	3
Brightness control	20

C

Capacity	
Fuel tank	2
Car audio	27
Carbon monoxide caution	49
Cassette tape player	27,30,32,33,35,37,38
Catalytic converter	1
Center vent	27
Changing the engine coolant	94
Changing the engine oil and filter	91
Changing the fuel control connector	90
Changing tires and wheels	118
Checking and replacing fuses	102
Checking brake and clutch fluid	104
Checking fusible links	104
Checking the brake booster	108
Checking the engine drive belts	96

Checking the engine oil level	91
Cigarette lighter and ashtray	21
Circuit breaker	104
Circuit breaker location	102
Cleaning the interior	75
Clock	19
Clutch	
Fluid level	104
Pedal freeplay	107
Cold weather	
Operation	59
Compact spare tire	65,121
Controls, Instrument panel	10
Cooling fans, Electric	89
Cooling system	
Coolant level	93
Engine overheating	63
Radiator and reservoir	93
Radiator cap	63
Winter driving tips	59
Corrosion prevention	73
Cruise control	53

D

Day-night rear view mirror	40
Defogger, Rear window	20
Dimmer switch, Headlight	12
Directional signals	12
Discharge warning light	15
Does your vehicle need repairing?	58
Door locks	4,5
Driving	
Driving tips	51

Manual transmission	52
Driving tips	
Driving with a manual transmission	52
Economical driving	56
Good braking practice	54
Good driving practice	52
Pretrip safety check	57
Wet and flooded road driving tips	55
Winter driving tips	59
During	
Break-in	3

E

Econodrive monitor	19
Economical driving	
Saving money on both fuel and repairs	56
Electrical system	
Battery	100, 101
Circuit breaker	104
Fuse and circuit breaker locations	102
Fuses	102
Fusible links	104
Spark plugs	97, 99
Emergency flasher switch	13
Emergency, In case of	
Blown fuse	102
Emergency flasher switch	13
Flat tire	64
If a retractable headlight does not operate	64
If your vehicle needs to be towed	72
If your vehicle will not start	61
Jump starting	62
Overheating	63

Towing	72
Engine	
Air cleaner	96
Anti-freeze	94
Before starting the engine	51
Catalytic converter	1
Changing the engine coolant	94
Changing the oil and filter	91
Checking the coolant level	93
Coolant	94
Drive belts	96
Electric cooling fans	89
Emission control device	1
Engine compartment	87
Exhaust gas caution	49
Flooded	61
Hood release	48
Oil consumption	116
Oil level	91
Oil pressure gauge	18
Overheating	63
Recommended oil	91
Spark plugs	97, 99
Starting procedure	51
Temperature gauge	17
Engine coolant	
Winter driving tips	59
Engine cooling fan warning light	15
Engine electrical system warning light	15
Engine oil	
Winter driving tips	59
Engine oil pressure gauge	18
Engine temperature gauge	17
Exhaust gas caution	49

F

Facts about engine oil consumption	116
Filter, Engine oil	91
Flasher, Headlight	12
Flat tire	
After changing wheels	71
Changing tires	69
Compact spare tire	65
If you have a flat tire	64
Jack point	68
Jacking precautions	64
Jacking up	68
Loosening wheel nuts	67
Lowering vehicle	70
Reinstalling wheel ornament	71
Removing wheel ornament	67
Wheel block	67
Wheel nuts	70
Fluid level	
Battery	100
Brake and clutch	104
Engine coolant	94
Washer fluid	105
Fog light switch, Rear	21
Foreign countries, Operation in	3
Freeplay	
Brake pedal	107
Clutch pedal	107
Steering wheel	107
Front seat	
Lumbar support	7
Position	5
Seat cushion angle	6

Seatback angle	5
Front trunk lid	47
Fuel	
Filler door opener	47
Fuel economy	56
Gauge	17
Operation in foreign countries	3
Recommendation	2
Tank cap	47
Tank capacity	2
Fuse locations	102
Fuses	
Fuse box	102
Fusible links	104

G

Gauge	
Engine oil pressure	18
Engine temperature	17
Fuel	17
Glovebox	39
Good driving practice	52

H

Hazard switch	13
Headlight dimmer switch	12
Headlights	
If a retractable headlight does not operate	64
Replacement	109,110
Headrests	7
Heater	21
High speed operation	

During break-in	3
Tires	117
Hood release, Engine	48
How to start the engine	51

I

Identification	
Engine	115
Vehicle	115
Ignition switch	11
Inflation pressure, Tire	117
Instrument panel	
Brightness control	20
Cigarette lighter and ashtray	21
Clock	19
Engine oil pressure gauge	18
Fuel gauge	17
Odometer	18
Tachometer	18
Trip meter	18
Instrument panel light control	20
Instrument panel overview	10
Interior light	41

J

Jack	
Location	65
Jump starting	62

K

Key	3
-----------	---

L

Light bulbs, Replacing	111
Lock	
Lock	46
Doors	4,5
Rear trunk lid	46
Rear trunk lid opener	46
Steering column	11
Low fuel level warning light	15

M

Maintenance	
Do-it-yourself maintenance	89
Does your vehicle need repairing?	58
Maintenance requirements	77
Maintenance schedule	78,80,83
Where to go for service	77
Manual transmission	
Driving with a manual transmission	52
Shift pattern	52
Shifting speed	52
Maximum allowable speed	
Manual transmission	52
Mirror	
Day-night rear view	40
Mirrors	
Folding rear view	40
Power rear view	40

N

New vehicle break-in	3
----------------------------	---

O

Odometer	18
Oil	
Changing the engine oil and filter	91
Consumption	116
Filter	91
Pressure gauge	18
Transaxle	106
Viscosity and grade	91
Open door warning light	15
Opener, Rear trunk lid	46
Operation in foreign countries	3
Overheating, Engine	17,63
Overview	
Engine compartment	87
Front trunk room	88

P

Parking brake	
Adjustment	108
Operation	38
Reminder light	38
Polishing	74
Power door locks	5
Power rear view mirror control	40
Power window switches	39
Pressure, Tire inflation	117
Pretrip safety check	57
Protecting your Toyota from corrosion	73
Push starting	61

R

Radiator	
Coolant, Engine	93
Radio	27
Radio, AM-FM	28,29,30,32,33,35,37
Rear fog light switch	21
Rear trunk lid	46
Rear trunk lid opener	46
Rear view mirror, Day-night	40
Rear view mirrors, Folding	40
Rear view mirrors, Power	40
Rear window defogger switch	20
Recommended oil	91
Replacing spark plugs	97,99
Replacing the wiper blades	105
Retractable headlights	
If a retractable headlight does not operate	64

S

Safety check, Pretrip	57
Seat belts	
Cleaning	75
Fastening	7
Seat belt tips	8
Seats	
Adjusting side supports	6
Service and maintenance	77
Side vents	26
Spare fuse	102
Spare tire	65
Spark plugs	
Replacement	97,99

Specifications

Fuel	2
Starting	
Cold weather	51
Engine	51
Jump starting	62
Push starting	61
Steering	
Column lock	11
Tilt steering wheel	13
Wheel freeplay	107
Sun roof	41
Sun shade	43,46
Switch	
Emergency flasher	13
Headlight dimmer and turn signal	12
Ignition	11
Rear fog light	21
Rear window defogger	20
Windshield wiper and washer	14

T

T-bar roof	43,44,45
Tachometer	18
Tilt steering wheel	13
Tires	
Changing	64
Compact spare tire	121
Damage	117
Flat tire	64
High speed operation	117
Inflation pressure	117
Repair	117

Replacement	118
Rotation	118
Snow tires	117,118
Spare	65
Tire information	117
Tread wear indicator	118
Tools	65
Towing	
Emergency towing	72
If your vehicle needs to be towed	72
Transaxle	
Oil level	106
Trip meter	18
Trunk lid opener, Rear	46
Trunk lid, Front	47
Trunk lid, Rear	46
Turn signals	12

V

Voltmeter	19
-----------------	----

W

Washer fluid	
Adding washer fluid	105
Washing and waxing	74
Wet and flooded road driving tips	55
Wheels	
Aluminum wheel	122
Damage	117
Replacement	117
Windshield wiper and washer switch	14
Winter driving tips	59

Wiper	
Blades	105