

# TOYOTA

**3S-GE, 3S-GTE, 5S-FE**

**ENGINE**

**REPAIR MANUAL**

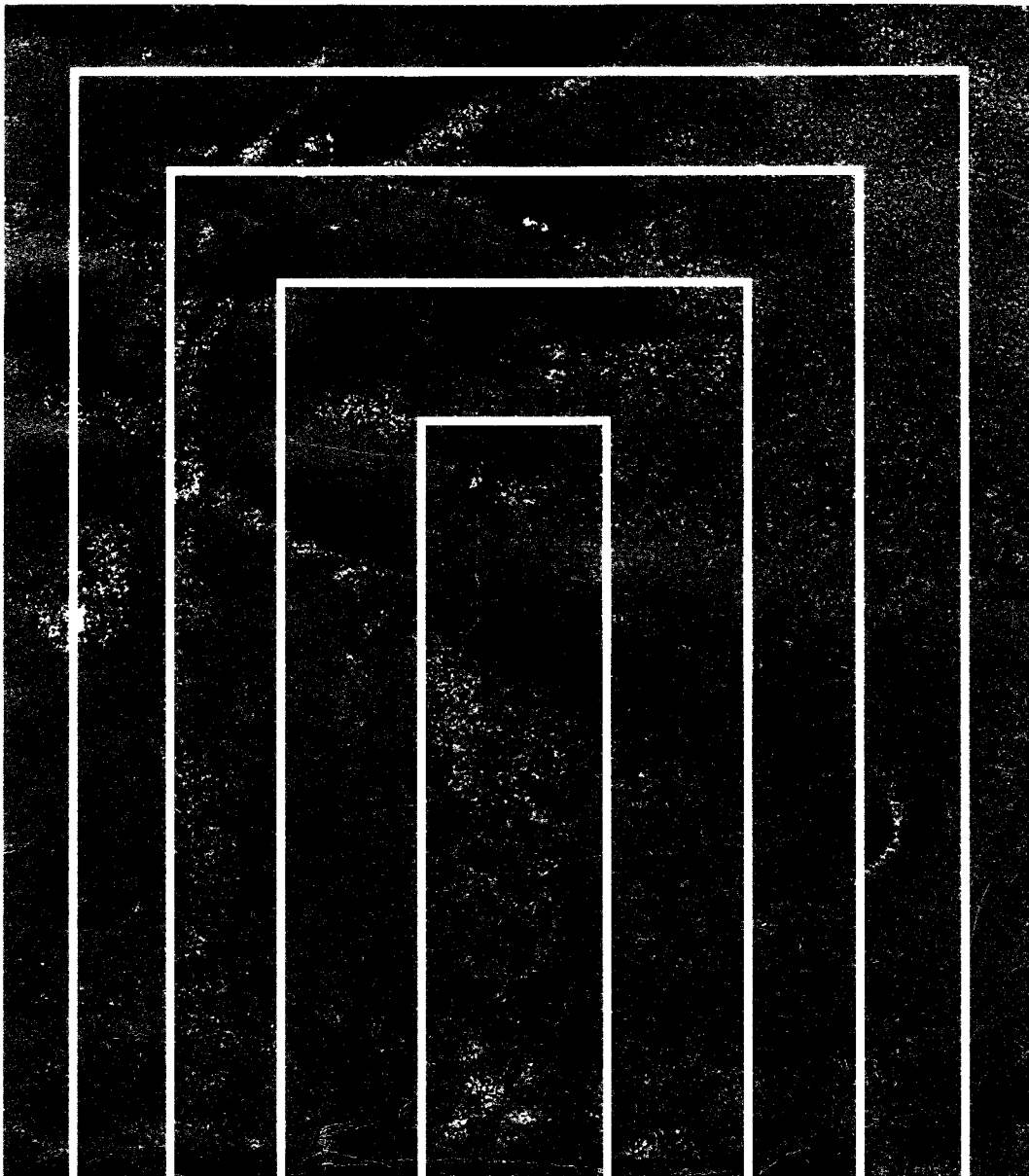

# TOYOTA 3S-GE, 3S-GTE, 5S-FE ENGINE REPAIR MANUAL

INTRODUCTION	IN
ENGINE MECHANICAL	EM
TURBOCHARGER SYSTEM	TC
EFI SYSTEM	FI
COOLING SYSTEM	CO
LUBRICATION SYSTEM	LU
IGNITION SYSTEM	IG
STARTING SYSTEM	ST
CHARGING SYSTEM	CH
SERVICE SPECIFICATIONS	A
STANDARD BOLT TORQUE SPECIFICATIONS	B
SST AND SSM	C

© 2002 TOYOTA MOTOR CORPORATION

All rights reserved. This book may not be reproduced or copied, in whole or in part, without the written permission of Toyota Motor Corporation.

First Printing: Nov. 14, 1989 01-891114-00

Seventeenth Printing: Mar. 14, 2002 17-020313-01-3

---

# INTRODUCTION

	Page
HOW TO USE THIS MANUAL .....	IN-2
IDENTIFICATION INFORMATION .....	IN-4
GENERAL REPAIR INSTRUCTIONS .....	IN-4
PRECAUTIONS FOR VEHICLES EQUIPPED WITH A CATALYTIC CONVERTER .....	IN-6
ABBREVIATIONS USED IN THIS MANUAL .....	IN-7

**IN**

# HOW TO USE THIS MANUAL

To assist you in finding your way through this manual, the Section Title and major heading are given at the top of every page.

An **INDEX** is provided on the 1st page of each section to guide you to the item to be repaired.

At the beginning of each section, **PRECAUTIONS** are given that pertain to all repair operations contained in that section.

*Read these precautions before starting any repair task.*

**TROUBLESHOOTING** tables are included for each system to help you diagnose the system problem and find the cause. The repair for each possible cause is referenced in the remedy column to quickly lead you to the solution.

## REPAIR PROCEDURES

Most repair operations begin with an overview illustration. It identifies the components and shows how the parts fit together.

Example:

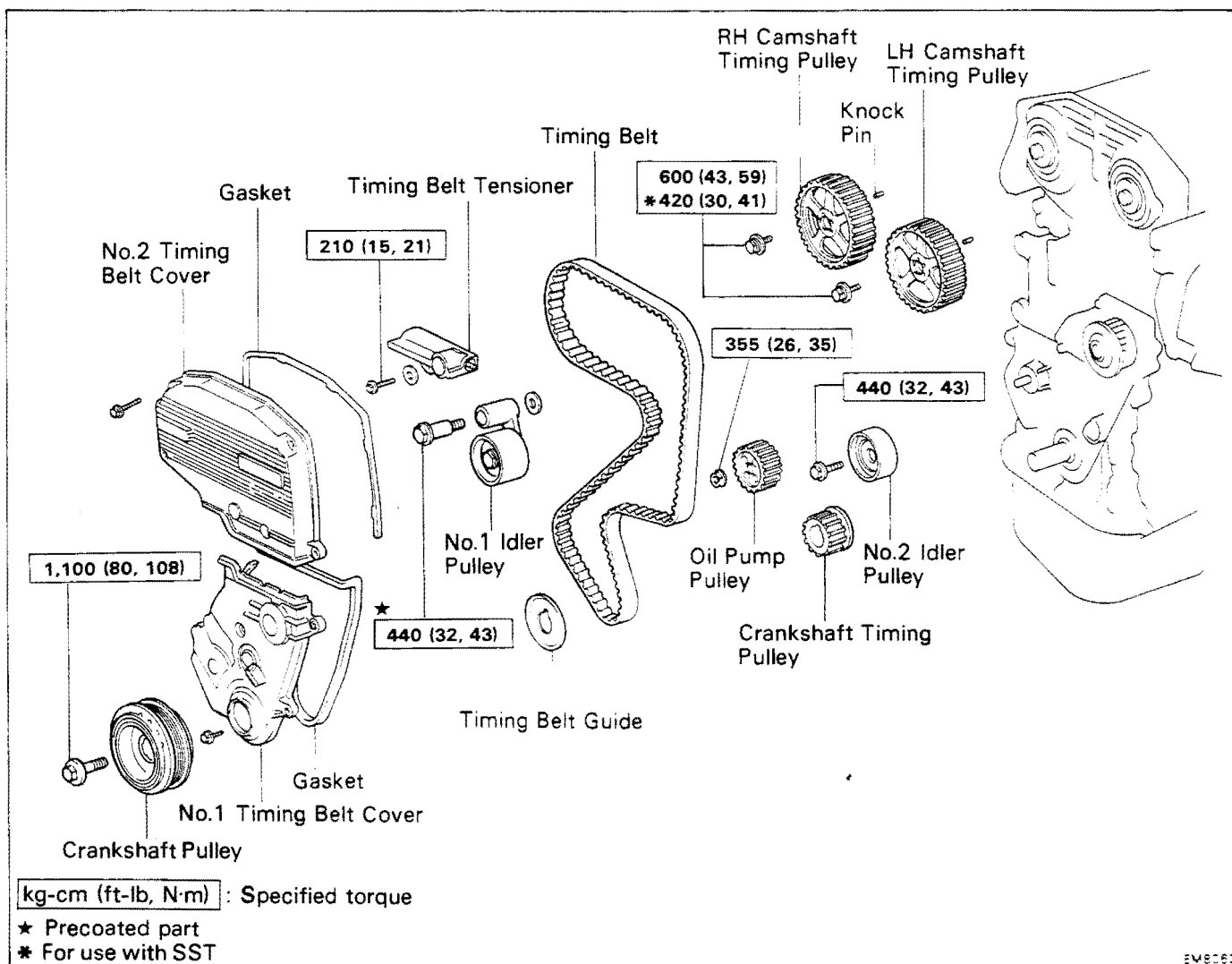

The procedures are presented in a step-by-step format:

- The illustration shows *what* to do and *where* to do it.
- The task heading tells *what* to do.
- The detailed text tells how to perform the task and gives other information such as specifications and warnings.

Example:

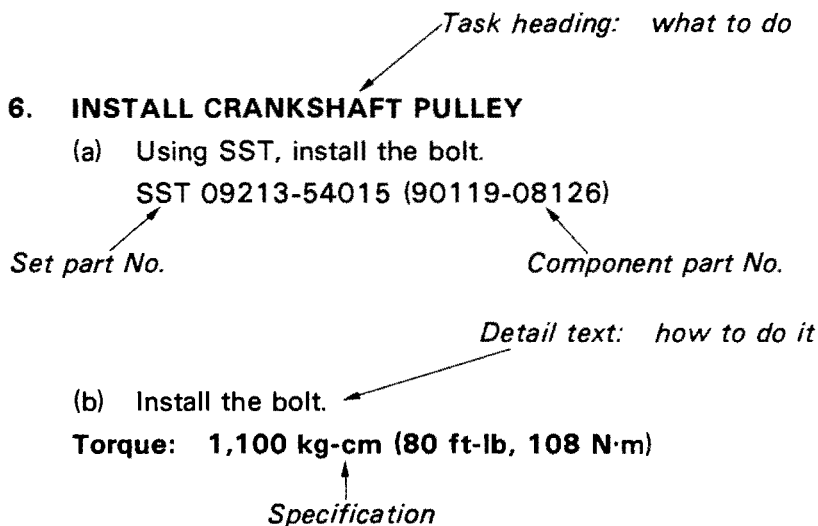
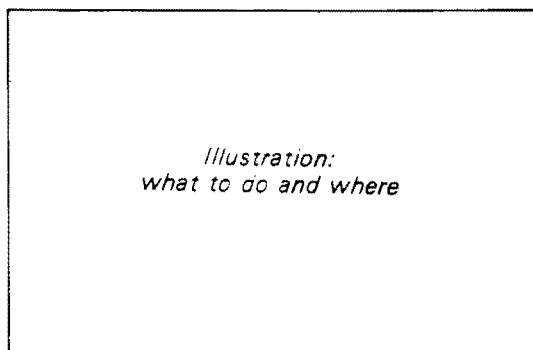

This format provides the experienced technician with a FAST TRACK to the information needed. The upper case task heading can be read at a glance and only when necessary, the text below it provides detailed information. Important specifications and warnings always stand out in bold type.

## REFERENCES

References have been kept to a minimum. However, when they are required, you are given the page to go to.

## SPECIFICATIONS

Specifications are presented in bold type throughout the text in the applicable step. You never have to leave the procedure to look up your specifications. All specifications are also found in Appendix A, specifications, for quick reference.

## CAUTIONS, NOTICES, HINTS:

- **CAUTIONS** are presented in bold type, and indicate there is a possibility of injury to you or other people.
- **NOTICES** are also presented in bold type, and indicate the possibility of damage to the components being repaired.
- **HINTS** are separated from the text but do not appear in bold. They provide additional information to help you efficiently perform the repair.

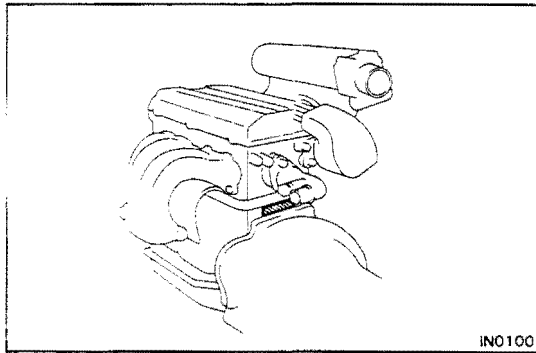

IN0100

## IDENTIFICATION INFORMATION

### ENGINE SERIAL NUMBER

The engine serial number is stamped on the rear side of the cylinder block.

## GENERAL REPAIR INSTRUCTIONS

1. Use fender, seat and floor covers to keep the vehicle clean and prevent damage.
2. During disassembly, keep parts in order to facilitate reassembly.
3. Observe the following:
  - (a) Before performing electrical work, disconnect the negative (–) cable from the battery terminal.
  - (b) If it is necessary to disconnect the battery for inspection or repair, always disconnect the cable from the negative (–) terminal which is grounded to the vehicle body.
  - (c) To prevent damage to the battery terminal post, loosen the terminal nut and raise the cable straight up without twisting or prying it.
  - (d) Clean the battery terminal posts and cable terminals with a shop rag. Do not scrape them with a file or other abrasive object.
  - (e) Install the cable terminal to the battery post with the nut loose, and tighten the nut after installation. Do not use a hammer to tap the terminal onto the post.
  - (f) Be sure the cover for the positive (+) terminal is properly in place.
4. Check hose and wiring connectors to make sure that they are secure and correct.
5. Non-reusable parts
  - (a) Always replace cotter pins, gaskets, O-rings, oil seals, etc. with new ones.
  - (b) Non-reusable parts are indicated in the component illustrations by the "◆" symbol.
6. Precoated Parts
 

Precoated parts are the bolts, nuts, etc. which are coated with a seal lock adhesive at the factory.

  - (a) If a precoated part is retightened, loosened or caused to move in any way, it must be recoated with the specified adhesive.

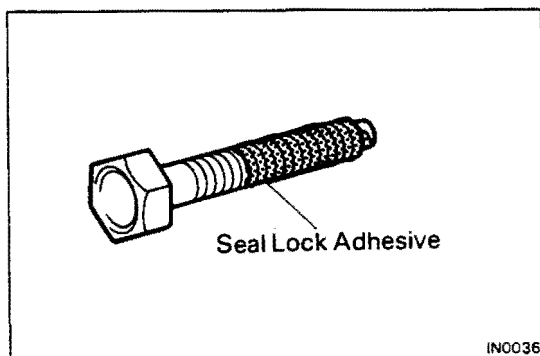

IN0036

- (b) Recoating of Precoated Parts
    - (1) Clean off the old adhesive from the part's threads.
    - (2) Dry with compressed air.
    - (3) Apply the specified seal lock adhesive to the part's threads.
  - (c) Precoated parts are indicated in the component illustrations by the "★" symbol.
7. When necessary, use a sealer on gaskets to prevent leaks.
  8. Carefully observe all specifications for bolt torques. Always use a torque wrench.
  9. Use of special service tools (SST) and special service materials (SSM) may be required, depending on the nature of the repair. Be sure to use SST and SSM where specified and follow the proper work procedure. A list of SST and SSM can be found at the back of this manual.
  10. When replacing fuses, be sure the new fuse is the correct amperage. DO NOT exceed the fuse amp rating or use one of a lower rating.
  11. Care must be taken when jacking up and supporting the vehicle. Be sure to lift and support the vehicle at the proper locations.
    - (a) If the vehicle is to be jacked up only at the front or rear end, be sure to chock the wheels in order to ensure safety.
    - (b) After the vehicle is jacked up, be sure to support it on stands. It is extremely dangerous to do any work on the vehicle raised on a jack alone, even for a small job that can be finished quickly.
  12. Observe the following precautions to avoid damaging the parts:
    - (a) Do not open the cover or the case of the ECU unless absolutely necessary. (If the IC terminals are touched, the IC may be destroyed by static electricity.)
    - (b) Be careful not to drop electrical components, such as sensors or relays. If they are dropped on a hard floor, they should be replaced and not reused.

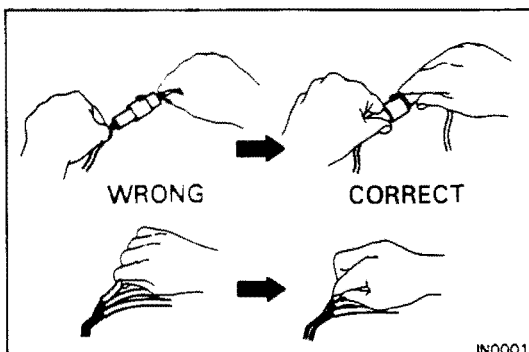

- (c) When disconnecting vacuum hoses, pull on the end of the hose, not the middle.
- (d) When separating electrical connectors, pull on the connector itself, not the wires.

- (e) When steam cleaning an engine, protect the distributor, coil, air filter, and VSV from water.
- (f) Never use an impact wrench to remove or install temp. switches or temp. sensors.
- (g) When checking continuity at the wire connector, insert the tester probe carefully to prevent terminals from bending.
- (h) When using a vacuum gauge, never force the hose onto a connector that is too large. Use a step-down adapter instead. Once the hose has been stretched, it may leak.

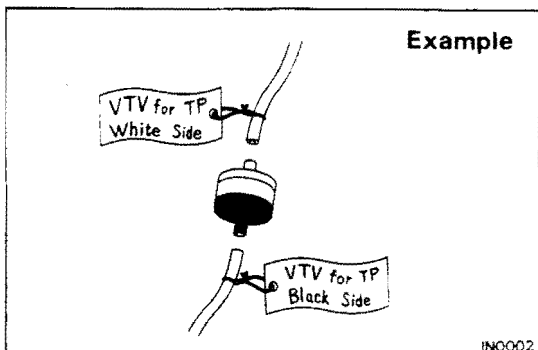

13. Tag hoses before disconnecting them:

- (a) When disconnecting vacuum hoses, use tags to identify how they should be reconnected.
- (b) After completing a job, double check that the vacuum hoses are properly connected. A label under the hood shows the proper layout.

## PRECAUTIONS FOR VEHICLES EQUIPPED WITH A CATALYTIC CONVERTER

**CAUTION:** If large amounts of unburned gasoline flow into the converter, it may overheat and create a fire hazard. To prevent this, observe the following precautions and explain them to your customer.

1. **Use only unleaded gasoline.**
2. **Avoid prolonged idling.**  
Avoid running the engine at idle speed for more than 20 minutes.
3. **Avoid spark jump test.**
  - (a) Perform spark jump test only when absolutely necessary and as quickly as possible.
  - (b) While testing, never race the engine.
4. **Avoid prolonged engine compression measurement.**  
Engine compression tests must be made as quickly as possible.
5. **Do not run engine when fuel tank is neary empty.**  
This may cause the engine to misfire and create an extra load on the converter.
6. **Avoid coasting with ignition turned off and prolonged braking.**
7. **Do not dispose of used catalyst along with parts contaminated with gasoline or oil.**



**ABBREVIATIONS USED IN THIS MANUAL**

A/C	Air Conditioner
ACIS	Acoustic Control Induction System
Approx.	Approximately
A/T	Automatic Transaxle
BTDC	Bottom Dead Center
BVSV	Bimetal Vacuum Switching Valve
ECU	Electronic Controlled Unit
ECT	Electronic Controlled Transaxle
EFI	Electronic Fuel Injection
EGR	Exhaust Gas Recirculation
ESA	Electronic Spark Advance
EVAP	Evaporative (Emission Control)
EX	Exhaust (Manifold, Valve)
Ex.	Except
FIPG	Formed in Place Gasket
FL	Fusible Link
FPU	Fuel Pressure Up
IG	Ignition
IN	Intake (Manifold, Valve)
ISC	Idle Speed Control
LH	Left-hand
LHD	Left-hand Drive
MP	Multipurpose
M/T	Manual Transaxle
OD, O/D	Overdrive
O/S	Oversized
PCV	Positive Crankcase Ventilation
PS	Power Steering
RH	Right-hand
RHD	Right-hand Drive
SSM	Special Service Materials
SST	Special Service Tools
STD	Standard
SW	Switch
TCCS	TOYOTA Computer Controlled System
TDC	Top Dead Center
T-VIS	TOYOTA-Variable Induction System
TWC	Three-Way Catalyst
U/S	Undersize
VSV	Vacuum Switching Valve
VTV	Vacuum Transmitting Valve
w/	With
w/o	Without

# ENGINE MECHANICAL

	Page
DESCRIPTION (5S-FE) .....	EM-2
DESCRIPTION (3S-GE and 3S-GTE) .....	EM-4
TROUBLESHOOTING .....	EM-7
ENGINE TUNE-UP .....	EM-11
ACOUSTIC CONTROL INDUCTION SYSTEM (ACIS) .....	EM-25
TOYOTA-VARIABLE INDUCSTION SYSTEM (T-VIS) .....	EM-26
IDLE HC/CO CONCENTRATION CHECK METHOD (w/ TWC) .....	EM-27
IDLE CO CONCENTRATION CHECK AND ADJUSTMENT METHOD (w/o TWC) .....	EM-29
COMPRESSION CHECK .....	EM-31
TIMING BELT (5S-FE) .....	EM-33
TIMING BELT (3S-GE and 3S-GTE) .....	EM-45
CYLINDER HEAD (5S-FE) .....	EM-64
CYLINDER HEAD (3S-GE and 3S-GTE) .....	EM-98
CYLINDER BLOCK (5S-FE) .....	EM-148
CYLINDER BLOCK (3S-GE and 3S-GTE) .....	EM-174

 EM

## DESCRIPTION (5S-FE)

The 5S-FE engine is an in-line, 4-cylinder, 2.2 liter DOHC 16-valve engine.

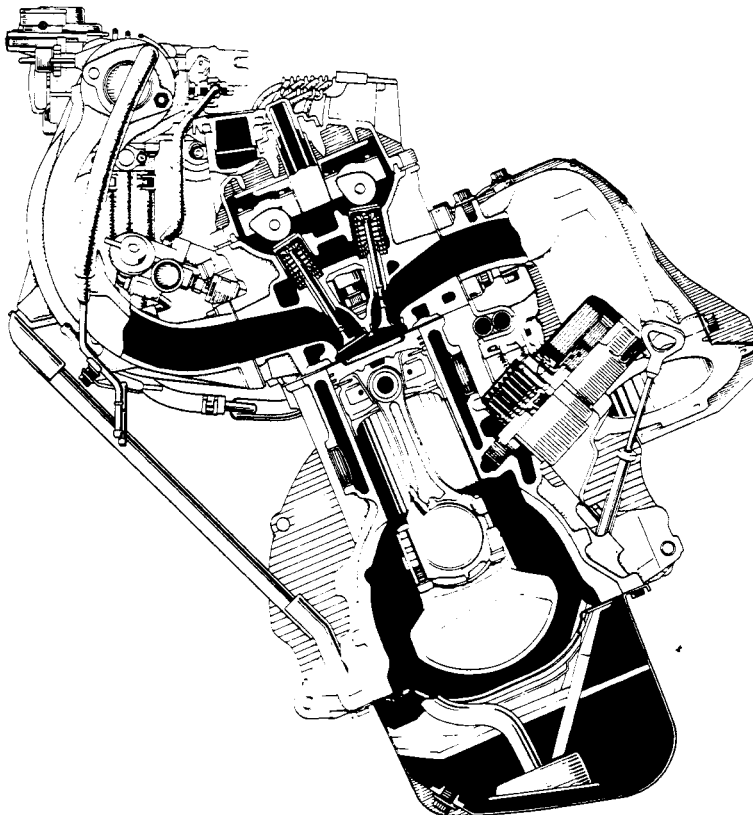
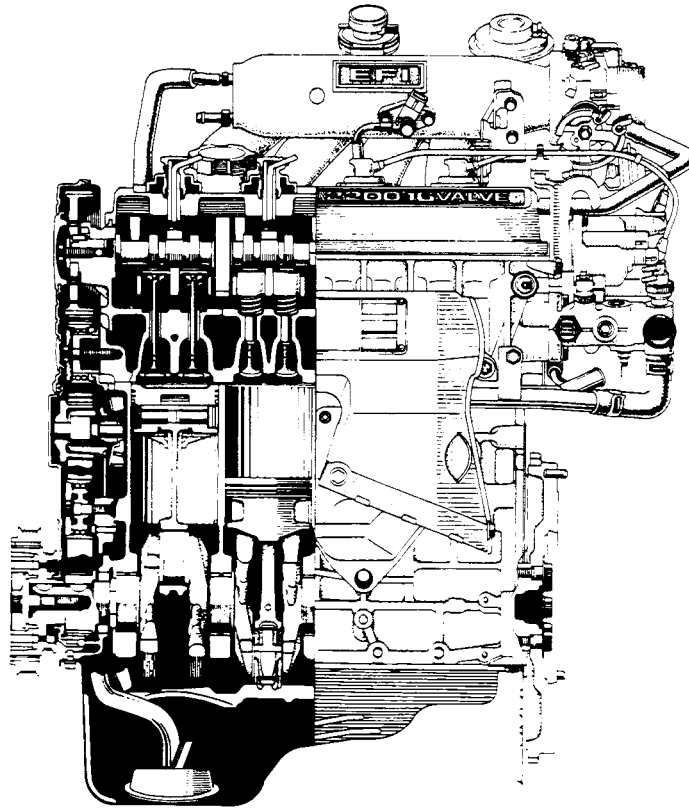

The 5S-FE engine is an in-line, 4 cylinder engine with the cylinders numbered 1 – 2 – 3 – 4 from the front. The crankshaft is supported by 5 bearings inside the crankcase. These bearings are made of aluminum alloy.

The crankshaft is integrated with 8 weights for balance. Oil holes are placed in the center of the crankshaft to supply oil to the connecting rods, bearing, pistons and other components.

The ignition order is 1 – 3 – 4 – 2. The cylinder head is made of aluminum alloy, with a cross flow type intake and exhaust layout and with pent-roof type combustion chambers. The spark plugs are located in the center of the combustion chambers.

The intake manifold has 4 independent long ports and utilizes the inertial super-charging effect to improve engine torque at low and medium speeds.

Exhaust and intake valves are equipped with irregular pitch springs made of special valve spring carbon steel which are capable of functioning no matter what the engine speed.

The intake camshaft is driven by a timing belt, and a gear on the exhaust camshaft engages with a gear on the exhaust camshaft to drive it. The cam journal is supported at 5 places between the valve lifters of each cylinder and on the front end of the cylinder head. Lubrication of the cam journals and gears is accomplished by oil supplied through the oiler port in the center of the camshaft.

Adjustment of the valve clearance is done by means of an outer shim type system, in which valve adjusting shims are located above the valve lifters. This permits replacement of the shims without removal of the camshafts.

Pistons are made of high temperature-resistant aluminum alloy, and a depression is built into the piston head to prevent interference with the valves.

Piston pins are the full-floating type, with the pins fastened to the neither the piston boss nor connecting rods. Instead, snap rings are fitted on both ends of the pins, preventing the pins from falling out.

The No.1 compression ring is made of steel and the No.2 compression ring is made of cast iron. The oil ring is made of a combination of steel and stainless steel. The outer diameter of each piston ring is slightly larger than the diameter of the piston and the flexibility of the rings allows them to hug the cylinder walls when they are mounted on the piston. Compression rings No.1 and No.2 work to prevent gas leakage from the cylinder and an oil ring works to clear oil off the cylinder walls to prevent it from entering the combustion chambers.

The cylinder block is made of cast iron. It has 4 cylinders which are approximately twice the length of the piston stroke. The top of the cylinders are closed off by the cylinder head and the lower end of the cylinders becomes the crankcase, in which the crankshaft is installed. In addition, the cylinder block contains a water jacket, through which coolant is pumped to cool the cylinders.

The oil pan is bolted onto the bottom of the cylinder block. The oil pan is an oil reservoir made of pressed steel sheet. A dividing plate is included inside the oil pan to keep sufficient oil in the bottom of the pan even when the vehicle is tilted. This dividing plate also prevents the oil from making waves when the vehicle is stopped suddenly and thus shifting the oil away from the oil pump suction pipe.

## DESCRIPTION (3S-GE and 3S-GTE)

The 3S-GE and 3S-GTE engines are an in-line, 4-cylinder, 2.0 liter DOHC 16-valve engine.

3S-GE

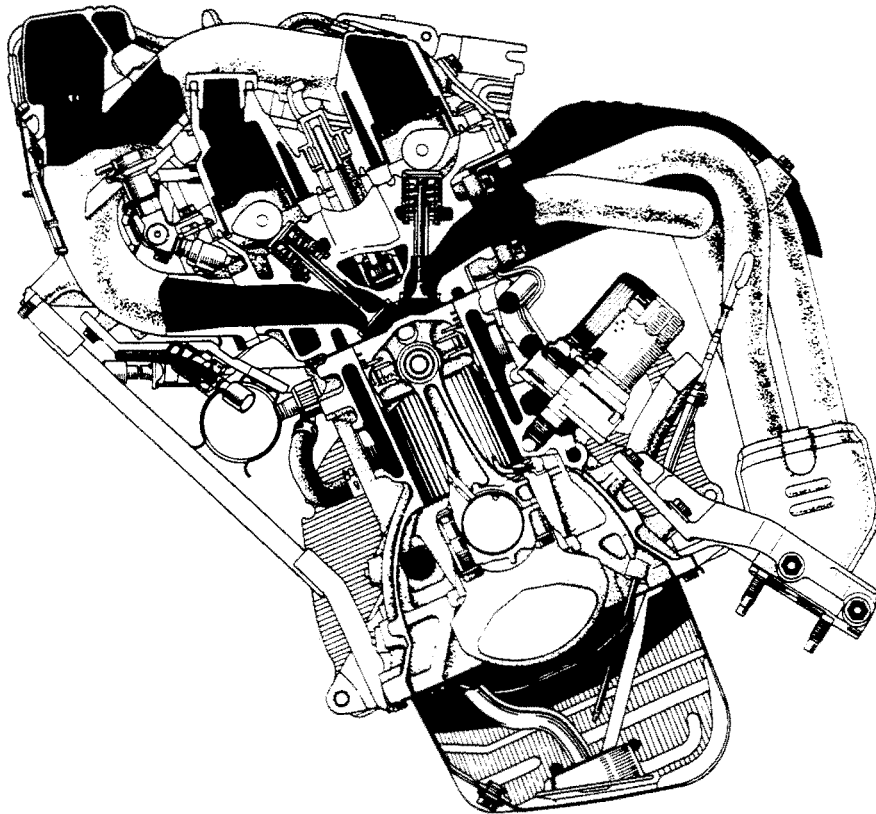
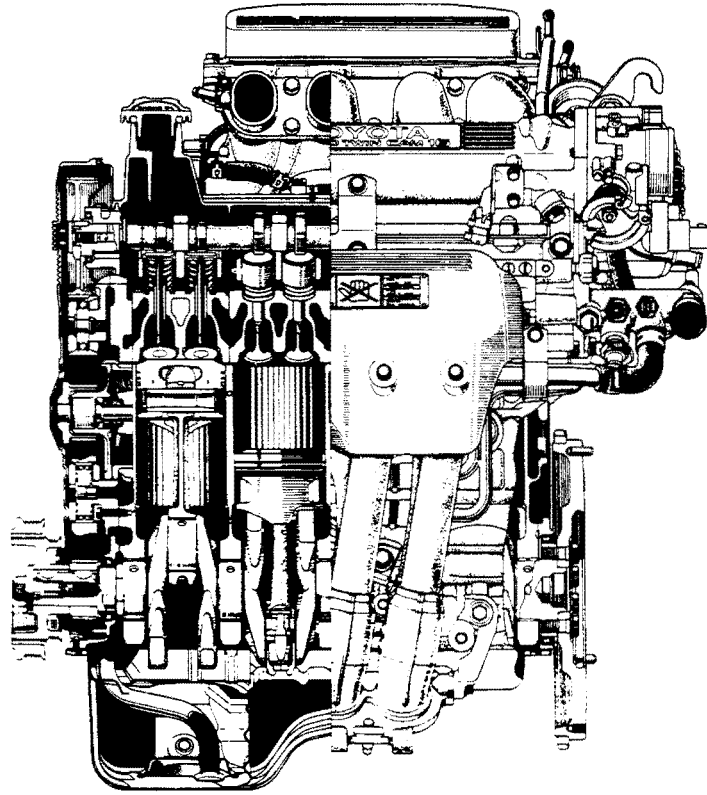

3S-GTE

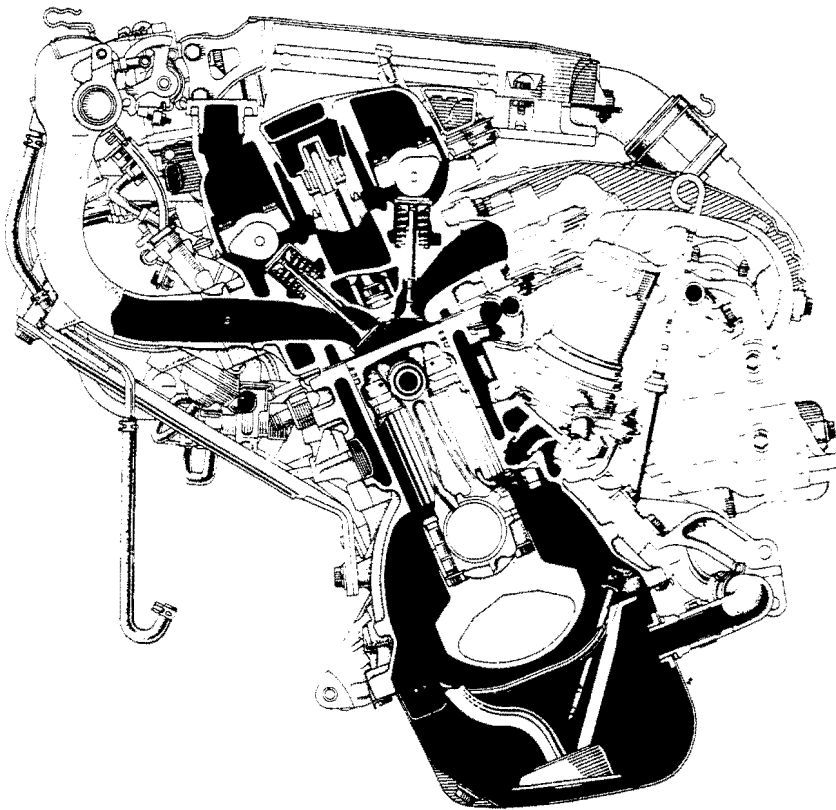
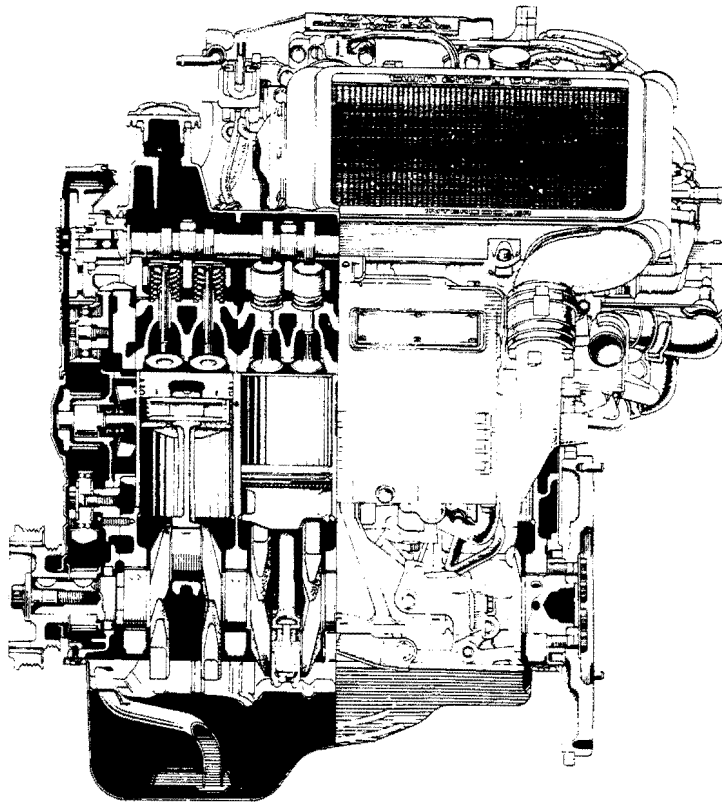

The 3S-GE and 3S-GTE engines are an in-line, 4 cylinder engine with the cylinders numbered 1 – 2 – 3 – 4 from the front. The crankshaft is supported by 5 bearings inside the crankcase. These bearings are made of aluminum alloy.

The crankshaft is integrated with 8 weights for balance. Oil holes are placed in the center of the crankshaft to supply oil to the connecting rods, bearing, pistons and other components.

The ignition order is 1 – 3 – 4 – 2. The cylinder head is made of aluminum alloy, with a cross flow type intake and exhaust layout and with pent-roof type combustion chambers. The spark plugs are located in the center of the combustion chambers.

The intake manifold has 4 (3S-GE) or 8 (3S-GTE) independent long ports and utilizes the inertial super-charging effect to improve engine torque at low and medium speeds.

Both the intake camshaft and the exhaust camshaft are driven by a single timing belt. The cam journal is supported at 5 places between the valve lifters of each cylinder and on the front end of the cylinder head. Lubrication of the cam journals and cam is accomplished by oil supplied through the oiler port in the center of the camshaft.

Adjustment of the valve clearance is done by means of an outer shim type system, in which valve adjusting shims are located above the valve lifters. This permits replacement of the shims without removal of the camshafts.

Pistons are made of high temperature-resistant aluminum alloy, and a depression is built into the piston head to prevent interference with the valves.

Piston pins are the full-floating type, with the pins fastened to the neither the piston boss nor connecting rods. Instead, snap rings are fitted on both ends of the pins, preventing the pins from falling out.

The No.1 compression ring is made of steel and the No.2 compression ring is made of cast iron. The oil ring is made of a combination of steel and stainless steel. The outer diameter of each piston ring is slightly larger than the diameter of the piston and the flexibility of the rings allows them to hug the cylinder walls when they are mounted on the piston. Compression rings No.1 and No.2 work to prevent gas leakage from the cylinder and an oil ring works to clear oil off the cylinder walls to prevent it from entering the combustion chambers.

The cylinder block is made of cast iron. It has 4 cylinders which are approximately twice the length of the piston stroke. The top of the cylinders are closed off by the cylinder head and the lower end of the cylinders becomes the crankcase, in which the crankshaft is installed. In addition, the cylinder block contains a water jacket, through which coolant is pumped to cool the cylinders.

The oil pan is bolted onto the bottom of the cylinder block. The oil pan is an oil reservoir made of pressed steel sheet. A dividing plate is included inside the oil pan to keep sufficient oil in the bottom of the pan even when the vehicle is tilted. This dividing plate also prevents the oil from making waves when the vehicle is stopped suddenly and thus shifting the oil away from the oil pump suction pipe.

## TROUBLESHOOTING

### ENGINE OVERHEATING

Problem	Possible cause	Remedy	Page
Engine overheats	Cooling system faulty Incorrect ignition timing	Troubleshoot cooling system Reset timing	CO-5

### HARD STARTING

Problem	Possible cause	Remedy	Page
Engine will not crank or cranks slowly	Starting system faulty	Troubleshoot starting system	ST-2
Engine will not start hard to start (cranks OK)	No fuel supply to injector <ul style="list-style-type: none"> <li>● No fuel in tank</li> <li>● Fuel pump no working</li> <li>● Fuel filter clogged</li> <li>● Fuel line clogged or leaking</li> </ul> EFI system problems Ignition problems <ul style="list-style-type: none"> <li>● Ignition coil</li> <li>● Igniter</li> <li>● Distributor</li> </ul> Spark plug faulty High-tension cords disconnected or broken Vacuum leaks <ul style="list-style-type: none"> <li>● PCV line</li> <li>● EGR line (5S-FE and 3S-GTE)</li> <li>● Intake manifold</li> <li>● Air intake chamber (3S-GE)</li> <li>● ACIS valve (3S-GE)</li> <li>● T-VIS valve (3S-GTE)</li> <li>● Throttle body</li> <li>● ISC valve</li> <li>● Brake booster line</li> </ul> Air suction between air flow meter and throttle body Low compression	Troubleshoot EFI system  Repair as necessary Perform spark test  Inspect plugs Inspect cords Repair as necessary  Repair as necessary  Check compression	FI-12  IG-5  IG-7, 8 IG-6  EM-31

### ROUGH IDLING

Problem	Possible cause	Remedy	Page
Rough idle, stalls or misses	Spark plug faulty	Inspect plugs	IG-7, 8
	High-tension cord faulty	Inspect cords	IG-6
	Ignition problems		
	<ul style="list-style-type: none"> <li>● Ignition coil</li> <li>● Igniter</li> <li>● Distributor</li> </ul>	Inspect coil Inspect igniter Inspect distributor	IG-10 IG-12 IG-11
	Incorrect ignition timing	Reset timing	EM-22, 23
	Vacuum leaks <ul style="list-style-type: none"> <li>● PCV line</li> <li>● EGR line (5S-FE and 3S-GTE)</li> <li>● Intake manifold</li> </ul>	Repair as necessary	



## ROUGH IDLING (Cont'd)

Problem	Possible cause	Remedy	Page
Rough idle, stalls or misses (Cont'd)	<ul style="list-style-type: none"> <li>● Air intake chamber (3S-GE)</li> <li>● ACIS valve (3S-GE)</li> <li>● T-VIS valve (3S-GTE)</li> <li>● Throttle body</li> <li>● ISC valve</li> <li>● Brake booster line</li> </ul>		
	Air suction between air flow meter and throttle body		
	Incorrect idle speed	Check ISC system	R-174, 176, 178
	Incorrect valve clearance	Adjust valve clearance	EM-13, 17
	EFI system problems	Repair as necessary	
	Engine overheats	Check cooling system	CO-5
	Low compression	Check compression	EM-31

## ENGINE HESITATES/POOR ACCELERATION

Problem	Possible cause	Remedy	Page
Engine hesitates/ poor acceleration	Spark plug faulty	Inspect plugs	IG-7, 8
	High-tension cord faulty	Inspect cords	IG-6
	Vacuum leaks <ul style="list-style-type: none"> <li>● PCV line</li> <li>● EGR line (5S-FE and 3S-GTE)</li> <li>● Intake manifold</li> <li>● Air intake chamber (3S-GE)</li> <li>● ACIS valve (3S-GE)</li> <li>● T-VIS valve (3S-GTE)</li> <li>● Throttle body</li> <li>● ISC valve</li> <li>● Brake booster line</li> </ul>	Repair as necessary	
	Air suction between air flow meter and throttle body	Repair as necessary	
	Incorrect ignition timing	Reset timing	EM-22, 23
	Incorrect valve clearance	Adjust valve clearance	EM-13, 17
	Fuel system clogged	Check fuel system	
	Air cleaner clogged	Check air cleaner	EM-11
	EFI system problems	Repair as necessary	
	Emission control system problem (cold engine) <ul style="list-style-type: none"> <li>● EGR system always on (5S-FE and 3S-GTE)</li> </ul>	Check EGR system	
	Engine overheats	Check cooling system	CO-5
	Low compression	Check compression	EM-31

**ENGINE DIESELING**

Problem	Possible cause	Remedy	Page
Engine diesels (runs after ignition switch is turned off)	EFI system problems Incorrect ignition timing EGR system faulty (5S-FE and 3S-GTE)	Repair as necessary Reset timing Check EGR system	EM-22, 23

**AFTER FIRE, BACKFIRE**

Problem	Possible cause	Remedy	Page
Muffler explosion (after fire) on deceleration only	Deceleration fuel cut system always off	Check EFI (fuel cut) system	
Muffler explosion (after fire) all the time	Air cleaner clogged EFI system problem Incorrect ignition timing	Check air cleaner Repair as necessary Reset timing	EM-11 EM-22, 23
Engine backfires	EFI system problem Vacuum leak <ul style="list-style-type: none"> <li>● PCV line</li> <li>● EGR line (5S-FE and 3S-GTE)</li> <li>● Intake manifold</li> <li>● Air intake chamber (3S-GE)</li> <li>● ACIS valve (3S-GE)</li> <li>● T-VIS valve (3S-GTE)</li> <li>● Throttle body</li> <li>● ISC valve</li> <li>● Brake booster line</li> </ul> Air suction between air flow meter and throttle body Insufficient fuel flow Incorrect ignition timing Incorrect valve clearance Carbon deposits in combustion chambers	Repair as necessary Check hoses and repair as necessary  Repair as necessary Troubleshoot fuel system Reset timing Adjust valve clearance Inspect cylinder head	FI-12 EM-22, 23 EM-13, 17 EM-76, 118

**EXCESSIVE OIL CONSUMPTION**

Problem	Possible cause	Remedy	Page
Excessive oil consumption	Oil leak PCV line clogged Piston ring worn or damaged Valve stem and guide bushing worn Valve stem oil seal worn	Repair as necessary Check PCV system Check rings Check valves and guide bushing Check seals	EM-160, 186 EM-77, 119

**EXCESSIVE FUEL CONSUMPTION**

<b>Problem</b>	<b>Possible cause</b>	<b>Remedy</b>	<b>Page</b>
Poor gasoline mileage	Fuel leak	Repair as necessary	
	Air cleaner clogged	Check air cleaner	EM-11
	Incorrect ignition timing	Reset timing	EM-22, 23
	EFI system problems <ul style="list-style-type: none"> <li>● Injector faulty</li> <li>● Deceleration fuel cut system faulty</li> </ul>	Repair as necessary	
	Idle speed too high	Check ISC system	R-174, 176, 178
	Spark plug faulty	Inspect plugs	IG-6
	EGR system always on (3S-FE and 3S-GTE)	Check EGR system	
	Low compression	Check compression	EM-31
	Tires improperly inflated	Inflate tires to proper pressure	
	Clutch slips	Troubleshoot clutch	
Brakes drag	Troubleshoot brakes		

**UNPLEASANT ODOR**

<b>Problem</b>	<b>Possible cause</b>	<b>Remedy</b>	<b>Page</b>
Unpleasant odor	Incorrect idle speed	Check ISC system	R-174, 176, 178
	Incorrect ignition timing	Reset timing	EM-22, 23
	Vacuum leaks <ul style="list-style-type: none"> <li>● PCV line</li> <li>● EGR line (5S-FE and 3S-GTE)</li> <li>● Intake manifold</li> <li>● Air intake chamber (3S-GE)</li> <li>● ACIS valve (3S-GE)</li> <li>● T-VIS valve (3S-GTE)</li> <li>● Throttle body</li> <li>● ISC valve</li> <li>● Brake booster line</li> </ul>	Repair as necessary	
	EFI system problems	Repair as necessary	

## ENGINE TUNE-UP

### INSPECTION OF ENGINE COOLANT

(See steps 1 and 2 on page CO-6)

### INSPECTION OF ENGINE OIL

(See steps 1 and 2 on page LU-6)

### INSPECTION OF BATTERY

(See steps 1 and 2 on page CH-3)

Standard specific gravity:

1.25 – 1.27 when fully charged at 20°C (68°F)

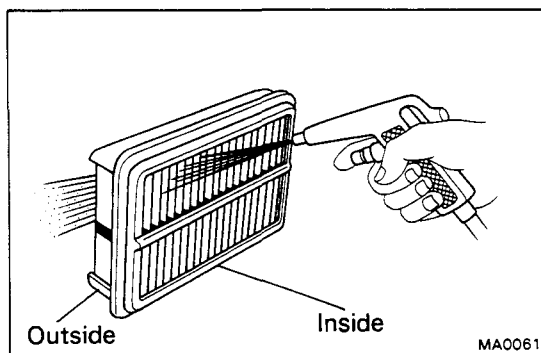

### INSPECTION OF AIR FILTER

#### 1. INSPECT AIR FILTER

Visually check that the element is not excessively dirty, damaged or oily.

#### 2. CLEAN AIR FILTER

Clean the element with compressed air.

First blow air from the inside thoroughly. Then blow off the outside of the element.

### INSPECTION OF HIGH-TENSION CORDS

(See page IG-6)

Maximum resistance: 25 k $\Omega$  per cord

### INSPECTION AND ADJUSTMENT OF SPARK PLUGS (Conventional Type only)

(See page IG-7)

#### 5S-FE

Correct electrode gap:	1.1 mm (0.043 in.)
Recommended spark plugs:	ND K16R-U11 NGK BKR5EYA11

#### 3S-GE

Correct electrode gap:	
Recommended spark plugs:	ND K20R-U NGK BKR6EYA

## INSPECTION AND ADJUSTMENT OF ALTERNATOR DRIVE BELT (5S-FE)

(See step 3 on page CH-3)

### Drive belt deflection:

w/ A/C	New belt	6 – 9 mm (0.24 – 0.35 in.)
	Used belt	9 – 11 mm (0.35 – 0.43 in.)
w/o A/C	New belt	11 – 15 mm (0.43 – 0.59 in.)
	Used belt	13 – 17 mm (0.51 – 0.67 in.)

### Drive belt tension (Reference):

w/ A/C	New belt	70 – 80 kg
	Used belt	45 – 55 kg
w/o A/C	New belt	45 – 55 kg
	Used belt	20 – 35 kg

## INSPECTION AND ADJUSTMENT OF ALTERNATOR DRIVE BELT (3S-GE AND 3S-GTE)

(See step 3 on page CH-3)

### Drive belt deflection:

w/ A/C	New belt	9 – 11 mm (0.35 – 0.43 in.)
	Used belt	13 – 16 mm (0.51 – 0.63 in.)
w/o A/C	New belt	11 – 14 mm (0.43 – 0.55 in.)
	Used belt	12 – 18 mm (0.47 – 0.71 in.)

### Drive belt tension (Reference):

w/ A/C	New belt	70 – 80 kg
	Used belt	30 – 45 kg
w/o A/C	New belt	47 – 72 kg
	Used belt	36 – 52 kg

## INSPECTION AND ADJUSTMENT OF VALVE CLEARANCE (5S-FE)

**HINT:** Inspect and adjust the valve clearance when the engine is cold.

1. **DISCONNECT HIGH-TENSION CORDS FROM SPARK PLUGS**
2. **REMOVE CYLINDER HEAD COVER**  
(See step 22 on page EM-70)

### 3. SET NO.1 CYLINDER TO TDC/COMPRESSION

- (a) Turn the crankshaft pulley and align its groove with timing mark "0" of the No.1 timing belt cover.
- (b) Check that the valve lifters on the No.1 cylinder are loose and valve lifters on No.4 are tight.

If not, turn the crankshaft one revolution (360°) and align the mark as above.

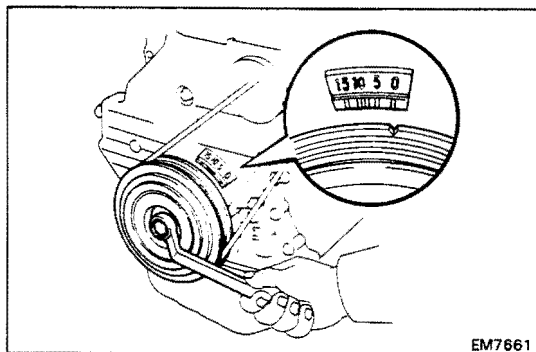

EM7661

### 4. INSPECT VALVE CLEARANCE

- (a) Check only those valves indicated.
  - Using a feeler gauge, measure the clearance between the valve lifter and camshaft.
  - Record the specifications of the valve clearance measurements. They will be used later to determine the required replacement adjusting shim.

#### Valve clearance (Cold):

**Intake** 0.19 – 0.29 mm (0.007 – 0.011 in.)  
**Exhaust** 0.28 – 0.38 mm (0.011 – 0.015 in.)

- (b) Turn the crankshaft one revolution (360°) and align the mark as above. (See procedure step 3)
- (c) Check only the valves indicated as shown. Measure the valve clearance. (See procedure step (a))

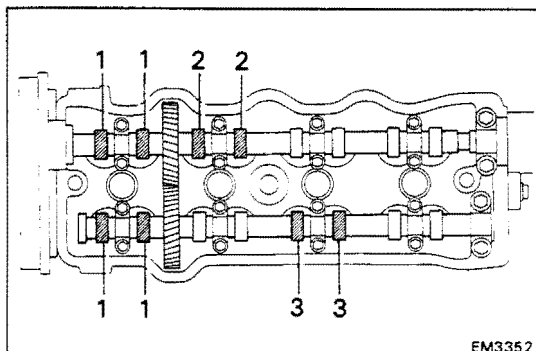

EM3352

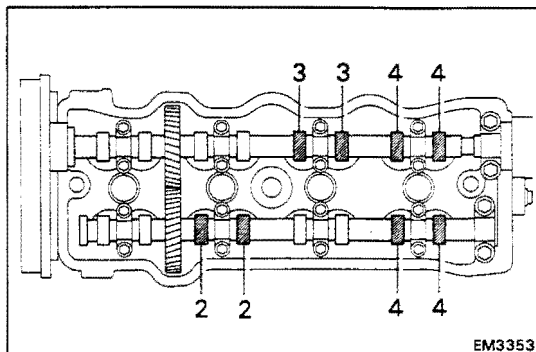

EM3353

### 5. ADJUST VALVE CLEARANCE

- (a) Remove the adjusting shim.
  - Turn the crankshaft to position the cam lobe of the camshaft on the adjusting valve upward.
  - Using SST (A), press down the valve lifter and place SST (B) between the camshaft and valve lifter. Remove SST (A).

SST 09248-55010

**HINT:** Before pressing down the valve lifter, position its notch toward the spark plug side.

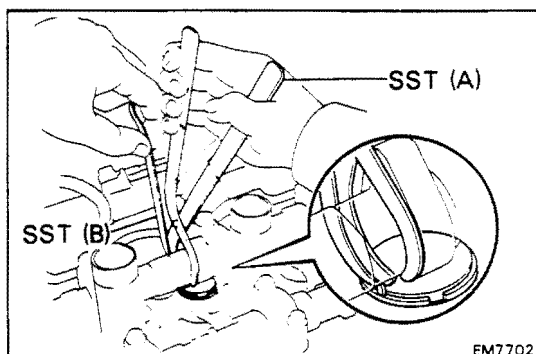

EM7702

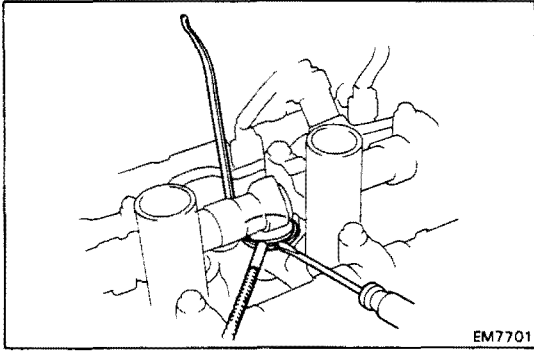

- Remove the adjusting shim with a small screwdriver and magnetic finger.

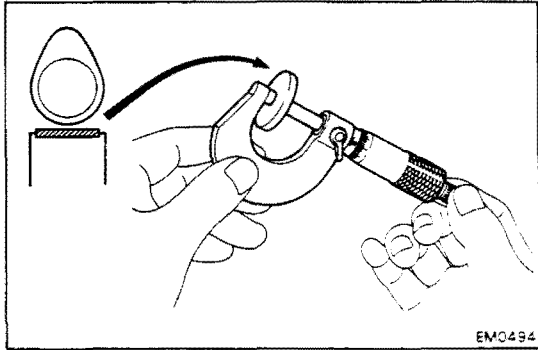

- (b) Determine the replacement adjusting shim size by following the Formula or Charts:

- Using a micrometer, measure the thickness of the removal shim.
- Calculate the thickness of a new shim so that the valve clearance comes within the specified value.

T . . . . Thickness of used shim

A . . . . Measured valve clearance

N . . . . Thickness of new shim

**Intake**     $N = T + (A - 0.24 \text{ mm (0.009 in.)})$

**Exhaust**    $N = T + (A - 0.33 \text{ mm (0.013 in.)})$

- Select a new shim with a thickness as close as possible to the calculated value.

**HINT:** Shims are available in seventeen sizes of 0.05 mm (0.0020 in.), from 2.50 mm (0.0984 in.) to 3.30 mm (0.1299 in.).

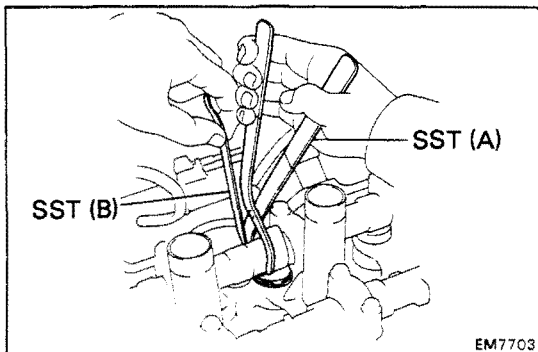

- (c) Install a new adjusting shim.

- Place a new adjusting shim on the valve lifter.
- Using SST (A), press down the valve lifter and remove SST (B).

SST 09248-55010

- (d) Recheck the valve clearance.

## 6. REINSTALL CYLINDER HEAD COVER (See step 7 on page EM-92)

## 7. RECONNECT HIGH-TENSION CORDS TO SPARK PLUGS







## INSPECTION AND ADJUSTMENT OF VALVE CLEARANCE (3S-GE AND 3S-GTE)

**HINT:** Inspect and adjust the valve clearance when the engine is cold.

1. (3S-GE)  
REMOVE AIR INTAKE CHAMBER  
(See step 13 on page EM-105)
2. (3S-GTE)  
REMOVE INTERCOOLER  
(See steps 4 to 6 on page TC-9)
3. DISCONNECT HIGH-TENSION CORDS FROM SPARK PLUGS
4. (3S-GTE)  
REMOVE EGR VACUUM MODULATOR  
(See step 13 on page EM-111)
5. (3S-GTE)  
REMOVE EGR VALVE AND PIPE  
(See step 14 on page EM-111)
6. (3S-GTE)  
REMOVE THROTTLE BODY  
(See steps 5 to 10 on pages FI-170 and 17)
7. REMOVE CYLINDER HEAD COVER  
3S-GE (See step 21 on page EM-106)  
3S-GTE (See step 26 on page EM-114)

### 8. SET NO.1 CYLINDER TO TDC/COMPRESSION

- (a) Turn the crankshaft pulley and align its groove with timing mark "0" of the No.1 timing belt cover.
- (b) Check that the valve lifters on the No.1 cylinder are loose and valve lifters on No.4 are tight.

If not, turn the crankshaft one revolution (360°) and align the mark as above.

### 9. INSPECT VALVE CLEARANCE

- (a) Check only those valves indicated.
  - Using a feeler gauge, measure the clearance between the valve lifter and camshaft.
  - Record the specifications of the valve clearance measurements. They will be used later to determine the required replacement adjusting shim.

#### Valve clearance (Cold):

Intake 0.15 – 0.25 mm (0.006 – 0.010 in.)  
Exhaust 0.20 – 0.30 mm (0.008 – 0.012 in.)

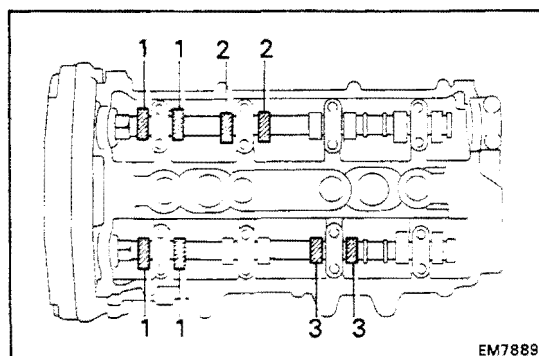
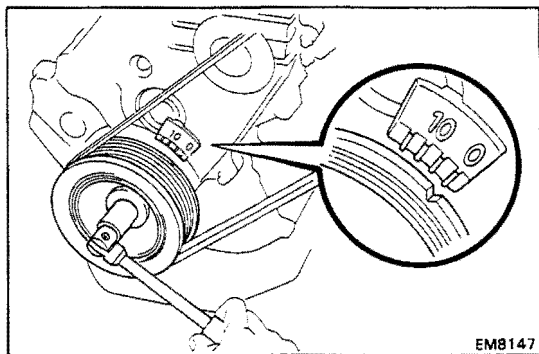

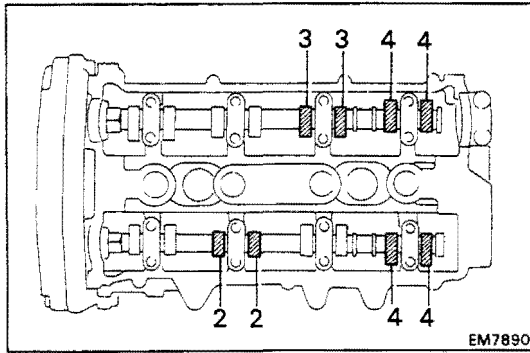

EM7890

- (b) Turn the crankshaft one revolution (360°) and align the mark as above. (See procedure step 3)
- (c) Check only the valves indicated as shown. Measure the valve clearance. (See procedure step (a))

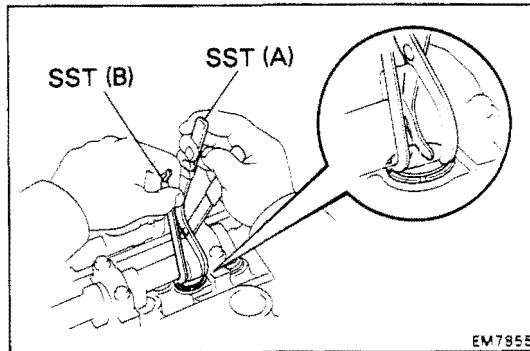

EM7855

## 10. ADJUST VALVE CLEARANCE

- (a) Remove the adjusting shim.
  - Turn the crankshaft to position the cam lobe of the camshaft on the adjusting valve upward.
  - Using SST (A), press down the valve lifter and place SST (B) between the camshaft and valve lifter. Remove SST (A).

SST 09248-55010

HINT: Before pressing down the valve lifter, position its notch toward the spark plug side.

- Remove the adjusting shim with small screwdriver and magnetic finger.

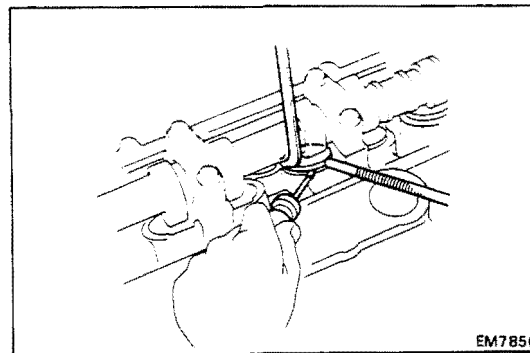

EM7856

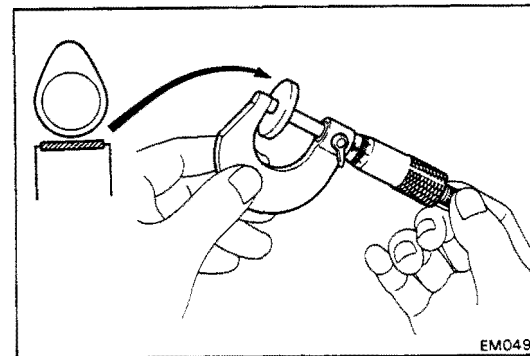

EM0494

- (b) Determine the replacement adjusting shim size by following the Formula or Charts:
    - Using a micrometer, measure the thickness of the removal shim.
    - Calculate the thickness of a new shim so that the valve clearance comes within the specified value.
 

T	.....	Thickness of used shim
A	.....	Measured valve clearance
N	.....	Thickness of new shim
- Intake     $N = T + (A - 0.20 \text{ mm (0.008 in.)})$   
 Exhaust    $N = T + (A - 0.25 \text{ mm (0.010 in.)})$
- Select a new shim with a thickness as close as possible to the calculated valve.

HINT: Shims are available in twenty-seven sizes of 0.05 mm (0.0020 in.), from 2.00 mm (0.0787 in.) to 3.30 mm (0.1299 in.).

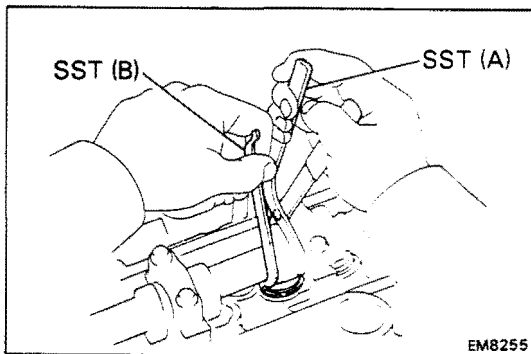

- (c) Install a new adjusting shim.
- Place a new adjusting shim on the valve lifter.
  - Using SST (A), press down the valve lifter and remove SST (B).

SST 09248-55010

- (d) Recheck the valve clearance.

11. **REINSTALL CYLINDER HEAD COVER**  
3S-GE (See step 7 on page EM-131)  
3S-GTE (See step 7 on page EM-140)
12. (3S-GTE)  
**REINSTALL THROTTLE BODY**  
(See steps 2 to 7 on pages FI-172 and 173)
13. (3S-GTE)  
**REINSTALL EGR VALVE AND PIPE**  
(See step 19 on page EM-143)
14. (3S-GTE)  
**REINSTALL EGR VACUUM MODULATOR**  
(See step 20 on page EM-143)
15. **RECONNECT HIGH-TENSION CORDS FROM SPARK PLUGS**
16. (3S-GTE)  
**REINSTALL INTERCOOLER**  
(See steps 11 to 13 on page TC-16)
17. (3S-GE)  
**REINSTALL AIR INTAKE CHAMBER**  
(See step 15 on page EM-132)





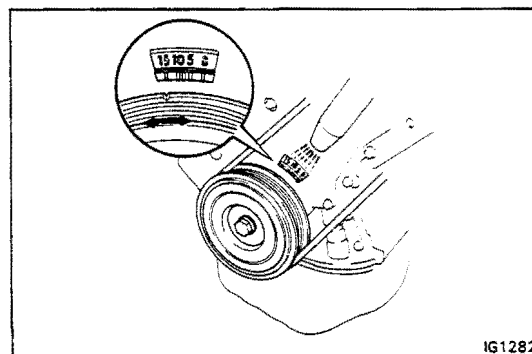
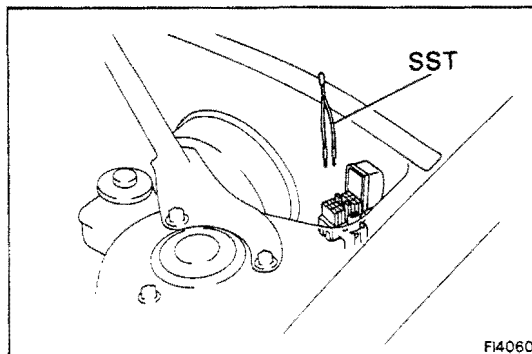
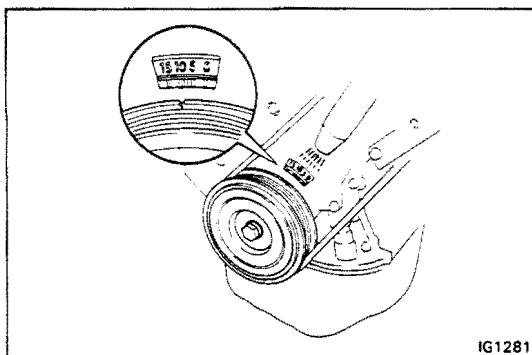
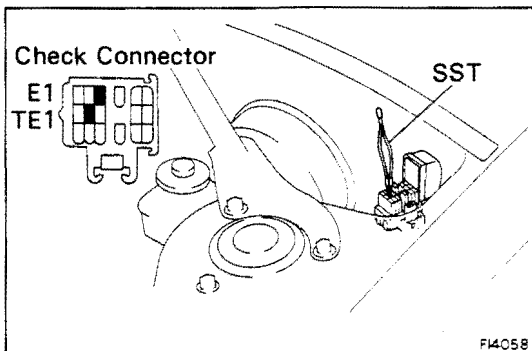
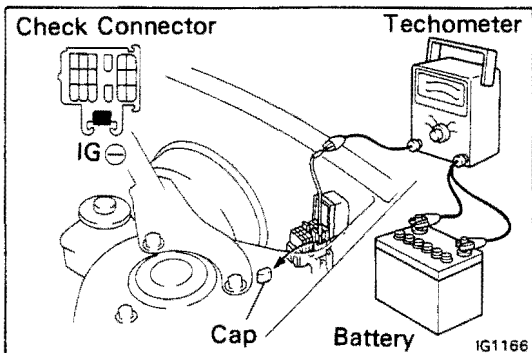

## INSPECTION AND ADJUSTMENT OF IGNITION TIMING (5S-FE)

### 1. WARM UP ENGINE

Allow the engine to warm up to normal operating temperature.

### 2. CONNECT TACHOMETER

Connect the test probe of a tachometer to terminal IG ⊖ of the check connector.

#### NOTICE:

- **NEVER** allow the tachometer terminal to touch ground as it could result in damage to the igniter and/or ignition coil.
- As some tachometers are not compatible with this ignition system, we recommend that you confirm the compatibility of your until before use.

### 3. INSPECT AND ADJUST IGNITION TIMING

- (a) Using SST, connect terminals TE1 and E1 of the check connector.

SST 09843-18020

HINT: Decrease the rpm after the engine maintains a speed of the 1,000 – 1,300 rpm for 5 seconds.

- (b) Using a timing light, check the ignition timing.

**Ignition timing: 10° BTDC @ idle**

- (c) Loosen the hold-down bolt, and adjust by turning the DISTRIBUTOR.
- (d) Tighten the hold-down bolt, and recheck the ignition timing.

**Torque: 130 kg-cm (9 ft-lb, 13 N·m)**

- (e) Remove SST.

SST 09843-18020

### 4. FURTHER CHECK IGNITION TIMING

**Ignition timing: 13 – 22° BTDC @ idle**

HINT: The timing mark moves in a range between 13° and 22°.

### 5. DISCONNECT TACHOMETER AND TIMING LIGHT FROM ENGINE

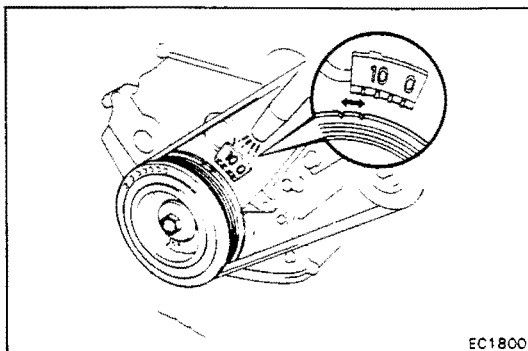
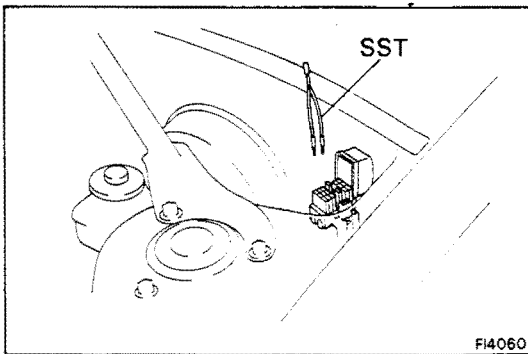
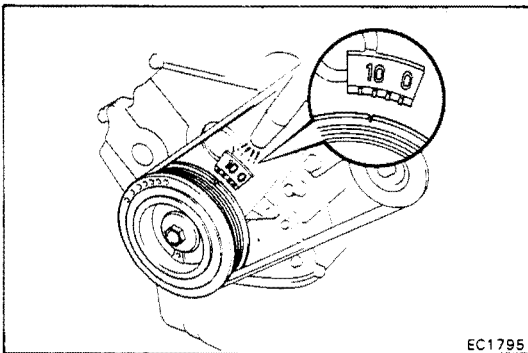
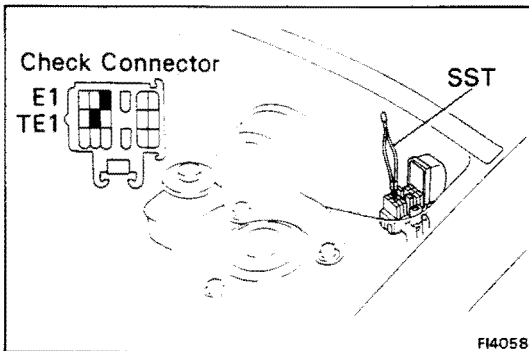
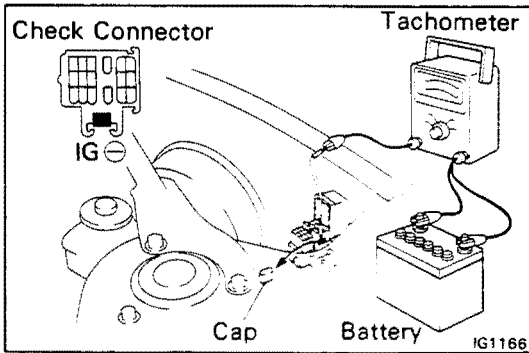

## INSPECTION AND ADJUSTMENT OF IGNITION TIMING (3S-GE AND 3S-GTE)

### 1. WARM UP ENGINE

Allow the engine to warm up to normal operating temperature.

### 2. CONNECT TACHOMETER

Connect the test probe of a tachometer to terminal IG $\ominus$  of the check connector.

#### NOTICE:

- NEVER allow the tachometer terminal to touch ground as it could result in damage to the igniter and/or ignition coil.
- As some tachometers are not compatible with this ignition system, we recommend that you confirm the compatibility of your until before use.

### 3. INSPECT AND ADJUST IGNITION TIMING

(a) Using SST, connect terminals TE1 and E1 of the check connector.

SST 09843-18020

HINT (3S-GE): Decrease the rpm after the engine maintains a speed of the 1,000 – 1,300 rpm for S seconds.

(b) Using a timing light, check the ignition timing.

Ignition timing: 10° BTDC @ idle

(c) Loosen the two hold-down bolts, and adjust by turning the DISTRIBUTOR.

(d) Tighten the hold-down bolts, and recheck the ignition timing.

Torque: 400 kg-cm (29 ft-lb, 39 N·m)

(e) Remove SST.

SST 09843-18020

### 4. FURTHER CHECK IGNITION TIMING

Ignition timing: 3S-GE 9 – 21° BTDC @ idle  
3S-GTE 12 – 21° BTDC @ idle

HINT: The timing mark moves in a range between 9 – 21° (3S-GE) or 12° and 21° (3S-GTE).

### 5. DISCONNECT TACHOMETER AND TIMING LIGHT FROM ENGINE



## INSPECTION AND ADJUSTMENT OF IDLE SPEED (5S-FE)

**HINT:** Disconnecting the battery will cause the idling speed data in the ISC to be returned to the initial idling speed, causing the idling speed to rise above 700 rpm. Should this happen, either carry out a driving test, including stop-go several times at a speed above 10 km/h, or start the engine, idle for 30 seconds and then turn the engine off repeatedly. By doing this, idle data will be stored in the ISC and the idle rpm will be at specified value.

### 1. INITIAL CONDITIONS

- (a) Engine at normal operating temperature
- (b) Air cleaner installed
- (c) All pipes and hoses of air induction system connected
- (d) All vacuum lines connected

**HINT:** All vacuum hoses for EGR systems, etc. should be properly connected.

- (e) EFI system wiring connectors fully plugged
- (f) All operating accessories switched OFF
- (g) Transmission in neutral range

### 2. CHECK ISC SYSTEM (See page FI-174)

### 3. CONNECT TACHOMETER (See page EM-22)

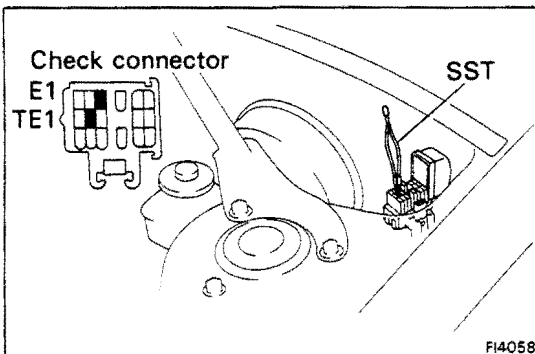

### 4. ADJUST IDLE SPEED

- (a) Using SST, connect terminals TE1 and E1 of the check connector.

SST 09843-18020

**HINT:** Decrease the rpm after the engine maintains a speed of the 1,000 – 1,300 rpm for 5 seconds.

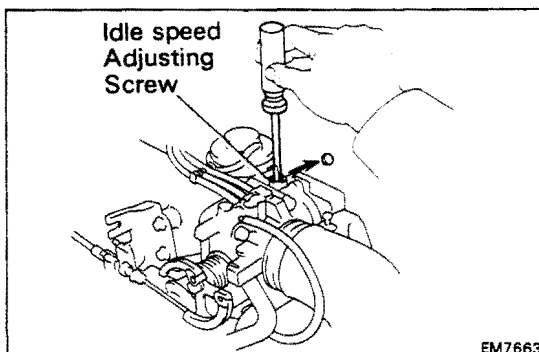

- (b) Check the idle speed.

**Idle speed: 650 rpm or more**

- (c) If the idle speed is not as specified, adjust the idle speed by turning the IDLE SPEED ADJUSTING SCREW.

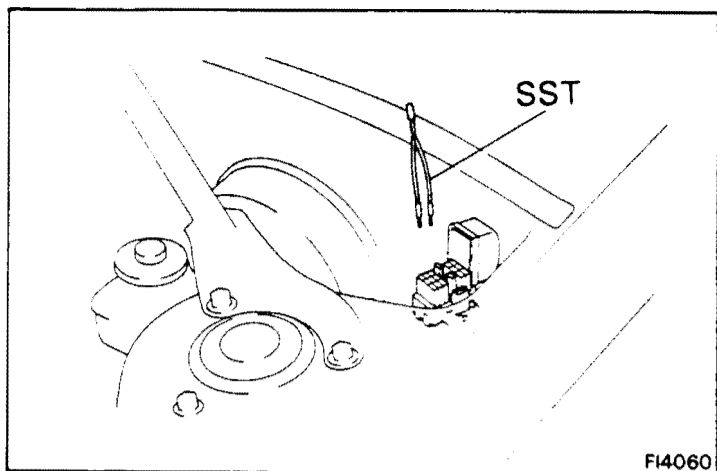

- (d) Remove SST.  
SST 09843-18020

**5. FURTHER CHECK IDLE SPEED**

**Idle speed: 700 ± 50 rpm**

If the idle speed is not within these values, carry out either of the below listed procedures and then recheck the idle speed.

Carry out a driving set, including stop-go several times at a speed above 10 km/h, or start the engine, idle for 30 seconds and then turn the engine off repeatedly. By doing this, idle data will be stored in the ISC and the idle rpm will be at specified value.

**INSPECTION OF IDLE SPEED (3S-GE and 3S-GTE)**

**Idle speed: 800 ± 50 rpm**

**INSPECTION OF ACOUSTIC CONTROL INDUCTION SYSTEM (ACIS) (3S-GE)**

**1. WARM UP AND STOP ENGINE**

Allow the engine to warm up to normal operating temperature.

**2. CONNECT TACHOMETER (See page EM-23)**

**3. CONNECT VACUUM GAUGE**

Using a 3-way connector, connect the vacuum gauge to the hose between the VSV and actuator.

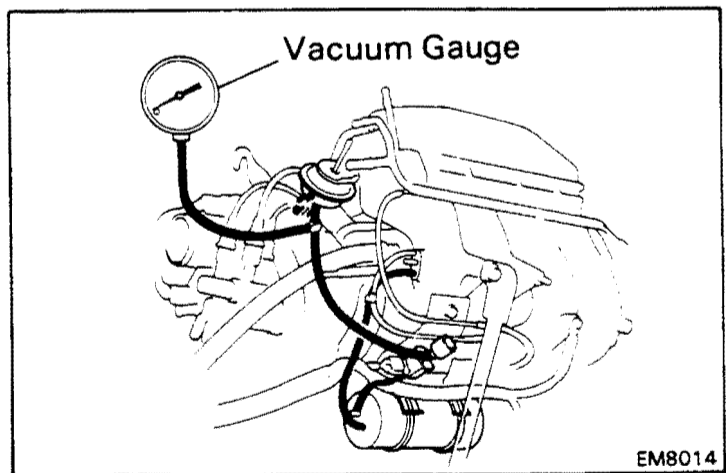

**4. INSPECT ACIS OPERATION**

- (a) Check that the vacuum gauge indicates vacuum at idling.

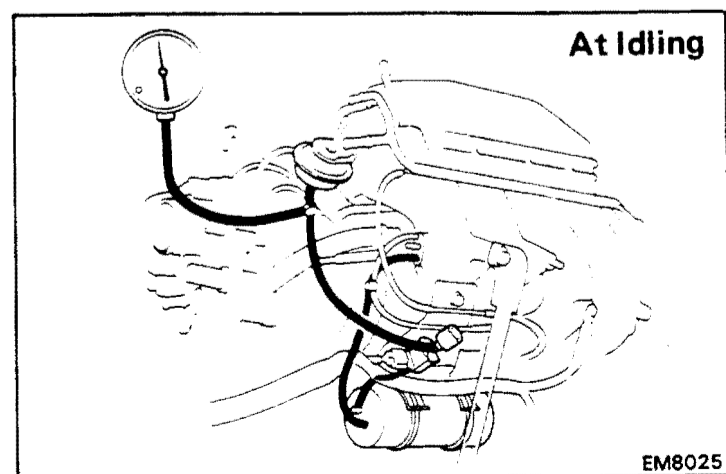

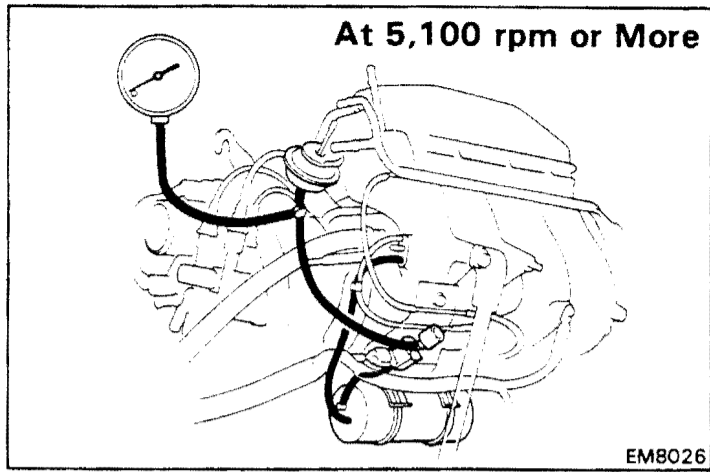

(b) Check that the vacuum gauge indicates zero at 5,100 rpm or more.

HINT: If regular unleaded gasoline is used, the vacuum gauge also indicates zero below 5,100 rpm.

## INSPECTION OF TOYOTA-VARIABLE INDUCTION SYSTEM (T-VIS) (3S-GTE)

### 1. WARM UP AND STOP ENGINE

Allow the engine to reach normal operating temperature.

### 2. CONNECT TACHOMETER (See page EM-23)

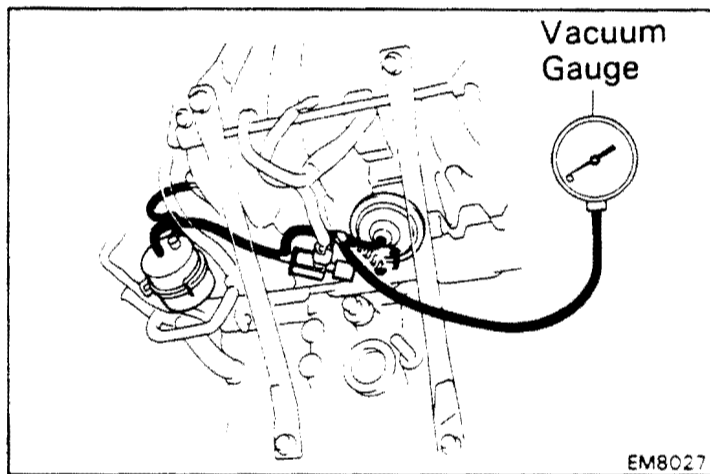

### 3. CONNECT VACUUM GAUGE

Using a 3-way connector, connect the vacuum gauge to the hose between the VSV and actuator.

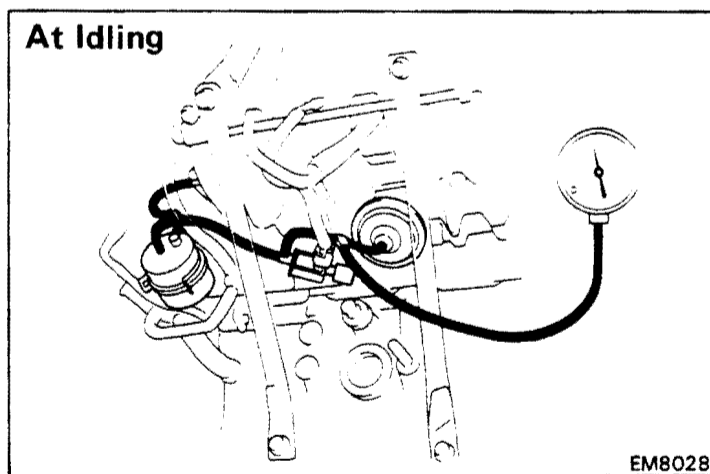

### 4. INSPECT T-VIS OPERATION

(a) Check that the vacuum gauge indicates vacuum at idling.

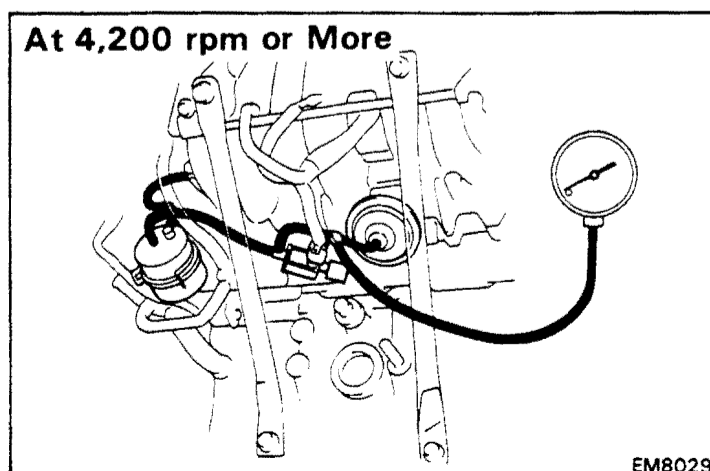

(b) Check that the vacuum gauge indicates zero at 4,200 rpm or more.

HINT: If regular unleaded gasoline is used, the vacuum gauge also indicates zero below 4,200 rpm.

## IDLE HC/CO CONCENTRATION CHECK METHOD (w/ TWC)

HINT: This check is used only to determine whether or not the idle HC/CO complies with regulations.

### 1. INITIAL CONDITIONS

- Engine at reach normal operating temperature
- Air cleaner installed
- All pipes and hoses of air induction system connected
- All accessories switched OFF
- All vacuum lines properly connected

HINT: All vacuum hoses for EGR systems (3S-GTE), etc. should be properly connected.

- EFI system wiring connectors fully plugged
- Ignition timing set correctly
- Transmission in neutral
- Tachometer and HC/CO meter calibrated and at hand.

### 2. CHECK OXYGEN SENSOR OPERATION

- Using SST, connect the terminals TE1 and E1 of the check connector.

SST 09843-18020

- Connect the positive (+) probe of a voltmeter to terminal VF1 of the check connector, and negative (-) probe to terminal E1.

- Hold the engine speed at 2,500 rpm for 120 seconds.

- Then, maintaining engine at 2,500 rpm, count how many times needle of voltmeter fluctuates between 0 and 5 V.

**Minimum needle fluctuation:**

**8 times for every 10 seconds**

If the fluctuation is less than minimum, check the air induction system. If necessary, see EFI SYSTEM.

- Remove the SST from the check connector.

SST 09843-18020

### 3. RACE ENGINE AT 2,500 RPM FOR APPROX. 120 SECONDS

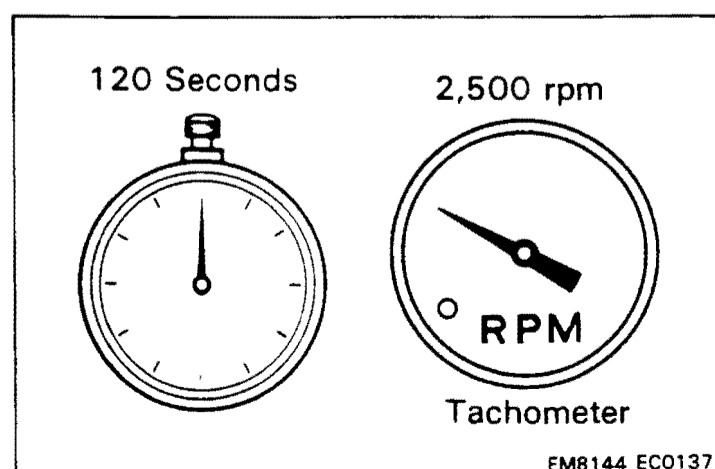
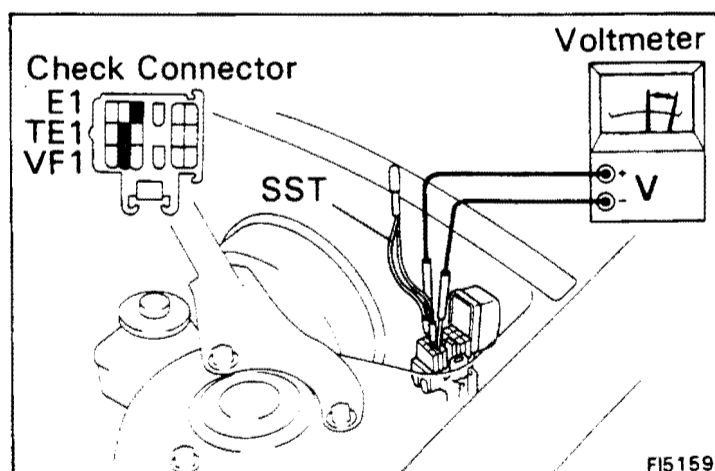
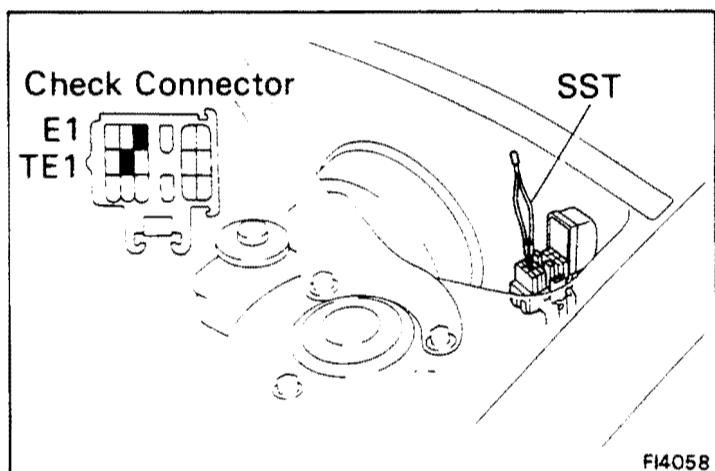

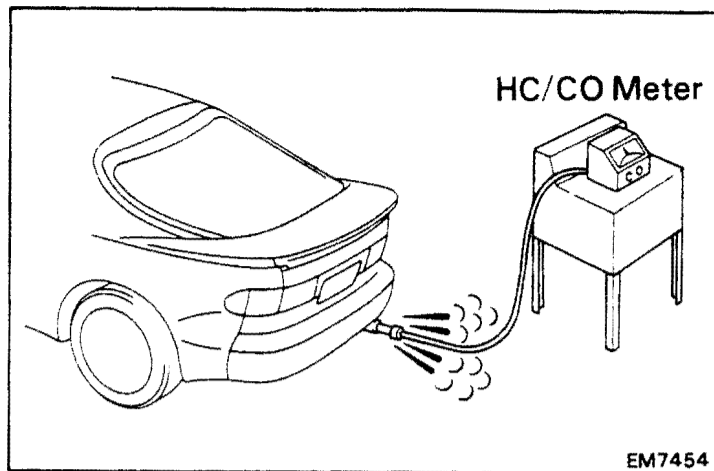

**4. INSERT HC/CO METER TESTING PROBE INTO TAILPIPE AT LEAST 40 cm (1.3 ft)**

**5. CHECK HC/CO CONCENTRATION AT IDLE**

Wait at least one minute before measuring to allow the concentration to stabilize. Complete the measuring within three minutes.

**Idle CO concentration: 0 – 0.5 %**

If the HC/CO concentration does not conform to regulations, see the table below for possible causes.

## Troubleshooting

HC	CO	Problems	Causes
High	Normal	Rough idle	<ol style="list-style-type: none"> <li>Faulty ignition: <ul style="list-style-type: none"> <li>● Incorrect timing</li> <li>● Fouled, shorted or improperly gapped plugs</li> <li>● Open or crossed high-tension cords</li> <li>● Cracked distributor cap</li> </ul> </li> <li>Incorrect valve clearance</li> <li>Leaky EGR valve</li> <li>Leaky intake and exhaust valves</li> <li>Leaky cylinder</li> </ol>
High	Low	Rough idle (Fluctuating HC reading)	<ol style="list-style-type: none"> <li>Vacuum leak: <ul style="list-style-type: none"> <li>● PCV hose</li> <li>● EGR valve</li> <li>● Intake manifold</li> <li>● Air intake camber (3S-GE and 3S-GTE)</li> <li>● Intake air control valve (3S-GE and 3S-GTE)</li> <li>● Throttle body</li> <li>● ISC valve</li> <li>● Brake booster line</li> </ul> </li> <li>Lean mixture causing misfire</li> </ol>
High	High	Rough idle (Black smoke from exhaust)	<ol style="list-style-type: none"> <li>Restricted air filter</li> <li>Faulty EFI system <ul style="list-style-type: none"> <li>● Faulty pressure regulator</li> <li>● Clogged fuel return line</li> <li>● Defective water temp. sensor</li> <li>● Defective air temp. sensor</li> <li>● Faulty ECU</li> <li>● Faulty injector</li> <li>● Faulty cold start injector</li> <li>● Faulty throttle position sensor</li> <li>● Air flow meter</li> </ul> </li> </ol>

## IDLE CO CONCENTRATION CHECK AND ADJUSTMENT METHOD (w/o TWC)

HINT: This check is used only to determine whether or not the idle CO complies with regulations.

### 1. INITIAL CONDITIONS

- (a) Engine at normal operating temperature
- (b) Air cleaner installed
- (c) All pipes and hoses of air induction system connected
- (d) All accessories switched OFF
- (e) All vacuum lines properly connected

HINT: All vacuum hoses should be properly connected.

- (f) EFI system wiring connectors fully plugged
- (g) Ignition timing set correctly
- (h) Transmission in neutral
- (i) Tachometer and CO meter calibrated and at hand.

### 2. CHECK AND ADJUST CO CONCENTRATION AT IDLE

**NOTICE:** Always use a CO meter when adjusting the idle mixture. It is not necessary to adjust with the idle mixture screw in most vehicle if they are in good condition. If a CO meter is not available, DO NOT ATTEMPT TO ADJUST IDLE MIXTURE.

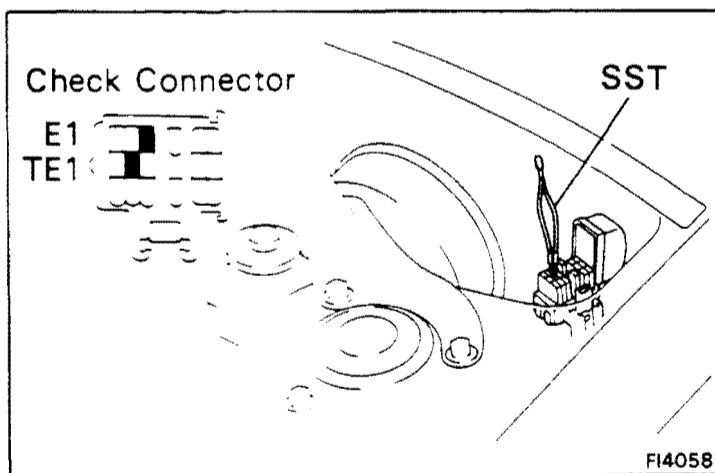

- (a) Using SST, connect terminals TE1 and E1 of the check connector.

SST 09843-18020

HINT: Decrease the rpm after the engine maintains a speed of the 1,000 – 1,300 rpm for 5 seconds.

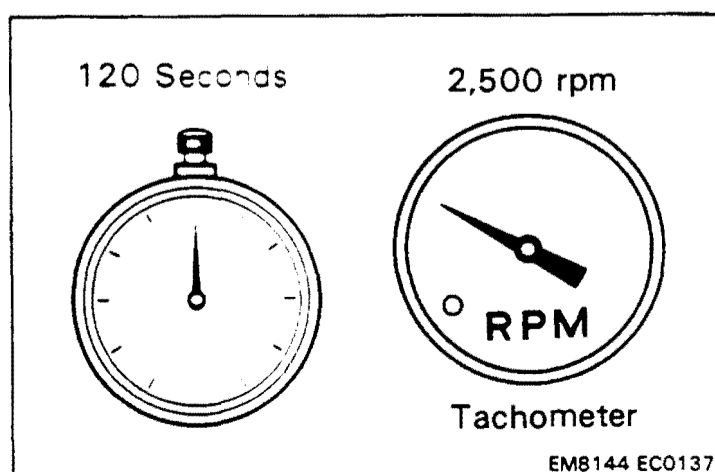

- (b) Race the engine at 2,500 rpm for approx. 120 seconds.

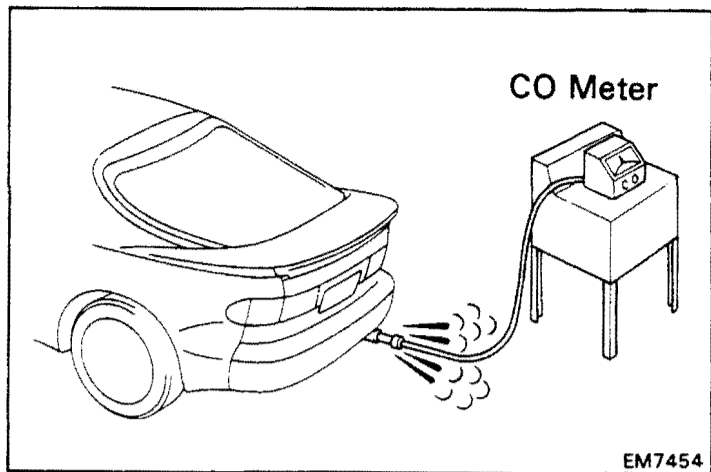

- (c) Insert a tester probe at least 40 cm (1.3 ft) into the tailpipe.
- (d) Wait at least one minute before measuring to allow the concentration to stabilize. Complete the measuring within three minutes.

**Idle CO concentration:  $1.0 \pm 0.5 \%$**   
**(w/ Cooling fan OFF)**

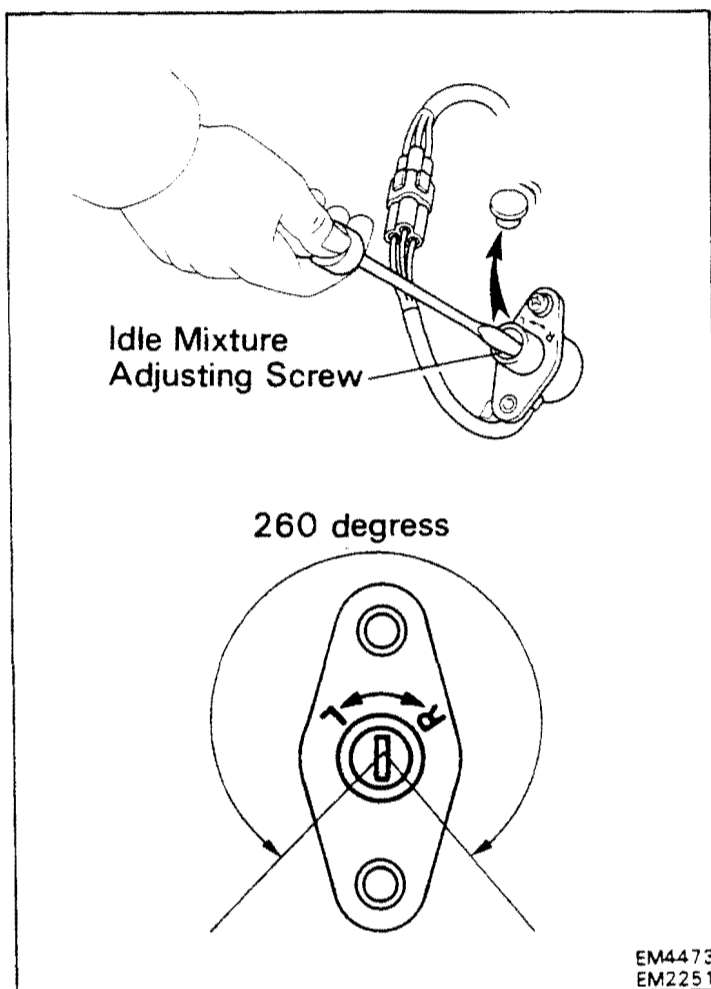

If the CO concentration does not conform to regulations, adjust by turning the IDLE MIXTURE ADJUSTING SCREW in the variable resistor.

**HINT:** The idle mixture adjusting screw can be tightened through an angle of  $260^\circ$

**LOCATION:** In the engine compartment on the left rear side.

- If the CO concentration is within specification, this adjustment is complete.
- If the CO concentration cannot be corrected by idle mixture adjustment, see the table on the page EM-28 for other possible causes.

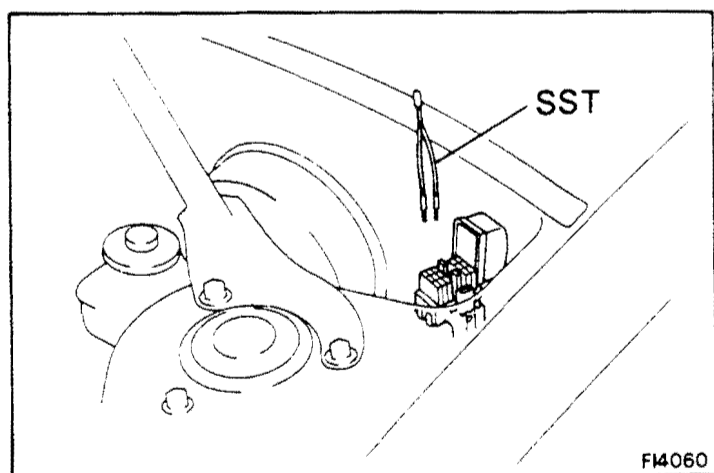

- (e) Remove SST.  
 SST 09843-18020

## COMPRESSION CHECK

**HINT:** If there is lack of power, excessive oil consumption or poor fuel economy, measure the compression pressure.

### 1. WARM UP AND STOP ENGINE

Allow the engine to warm up to normal operating temperature.

### 2. (3S-GTE)

#### REMOVE INTERCOOLER

(See steps 4 to 6 page TC-9)

### 3. DISCONNECT COLD START INJECTOR CONNECTOR

### 4. DISCONNECT DISTRIBUTOR CONNECTOR

### 5. REMOVE SPARK PLUGS

### 6. CHECK CYLINDER COMPRESSION PRESSURE

- Insert a compression gauge into the spark plug hole.
- Fully open the throttle.
- While cranking the engine, measure the compression pressure.

**HINT:** Always use a fully charged battery to obtain engine speed of 250 rpm or more.

- Repeat steps (a) through (c) for each cylinder.

**NOTICE:** This measurement must be done in as short a time as possible.

#### Compression pressure:

##### 5S-FE and 3S-GE

12.5 kg/cm<sup>2</sup> (178 psi, 1,226 kPa) or more

3S-GTE 11.5 kg/cm<sup>2</sup> (164 psi, 1,128 kPa) or more

#### Minimum pressure:

##### 5S-FE and 3S-GE

10.0 kg/cm<sup>2</sup> (142 psi, 981 kPa)

3S-GTE 9.0 kg/cm<sup>2</sup> (128 psi, 883 kPa)

#### Difference between each cylinder:

1.0 kg/cm<sup>2</sup> (14 psi, 98 kPa) or less

- If the cylinder compression in one or more cylinders are low, pour a small amount of engine oil into the cylinder through the spark plug hole and repeat steps (a) through (c) for cylinders with low compression.

- If adding oil helps the compression, chances are that the piston rings and/or cylinder bore are worn or damaged.
- If pressure stays low, a valve may be sticking or seating is improper, or there may be leakage past the gasket.

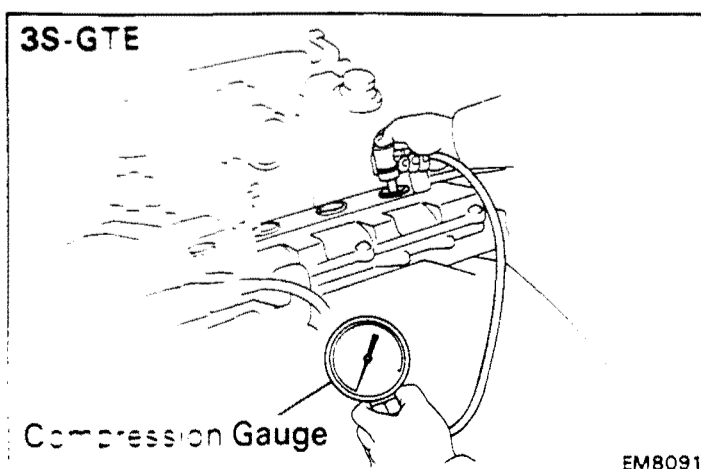
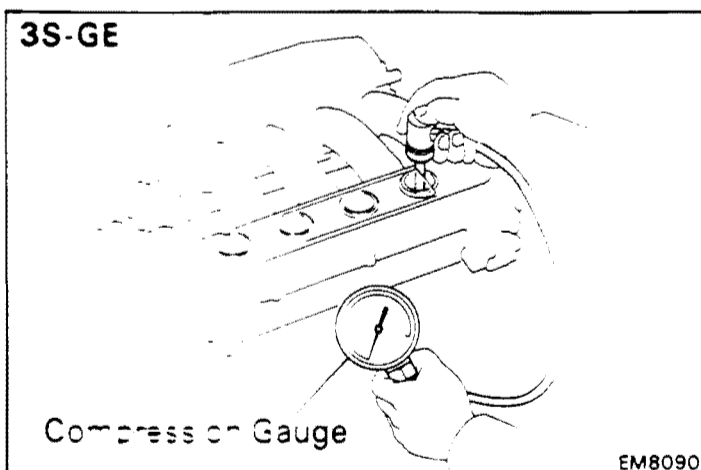
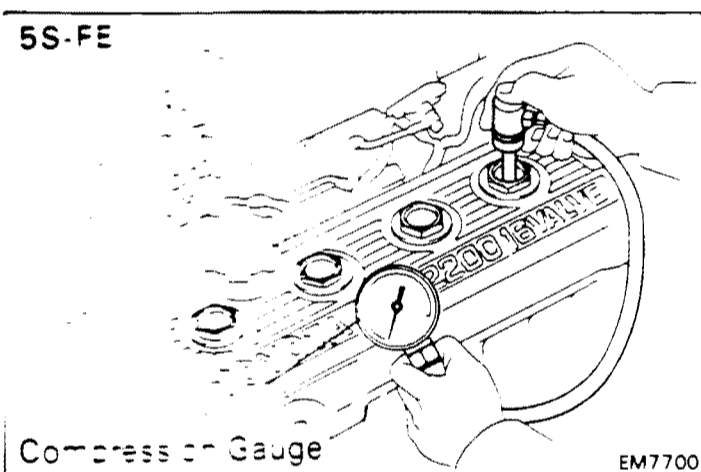



7. **REINSTALL SPARK PLUGS**  
Torque: 180 kg-cm (13 ft-lb, 18 N·m)
8. **RECONNECT DISTRIBUTOR CONNECTOR(S)**
9. **RECONNECT COLD START INJECTOR CONNECTOR**
10. **(3S-GTE)**  
**REINSTALL INTERCOOLER**  
(See steps 11 to 13 page TC-15)

# TIMING BELT (5S-FE)

## COMPONENTS

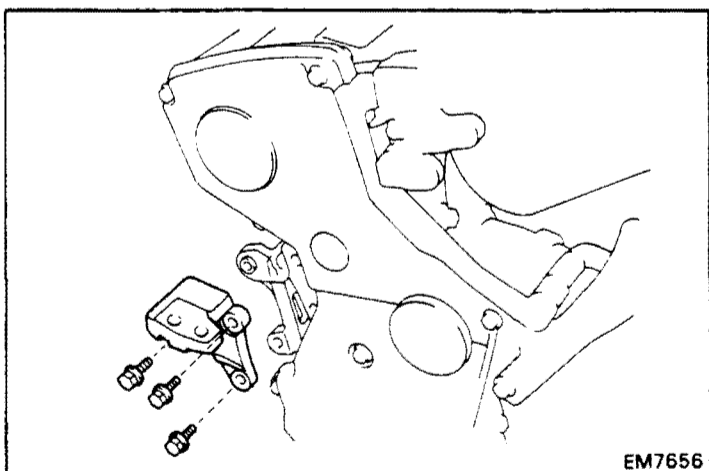
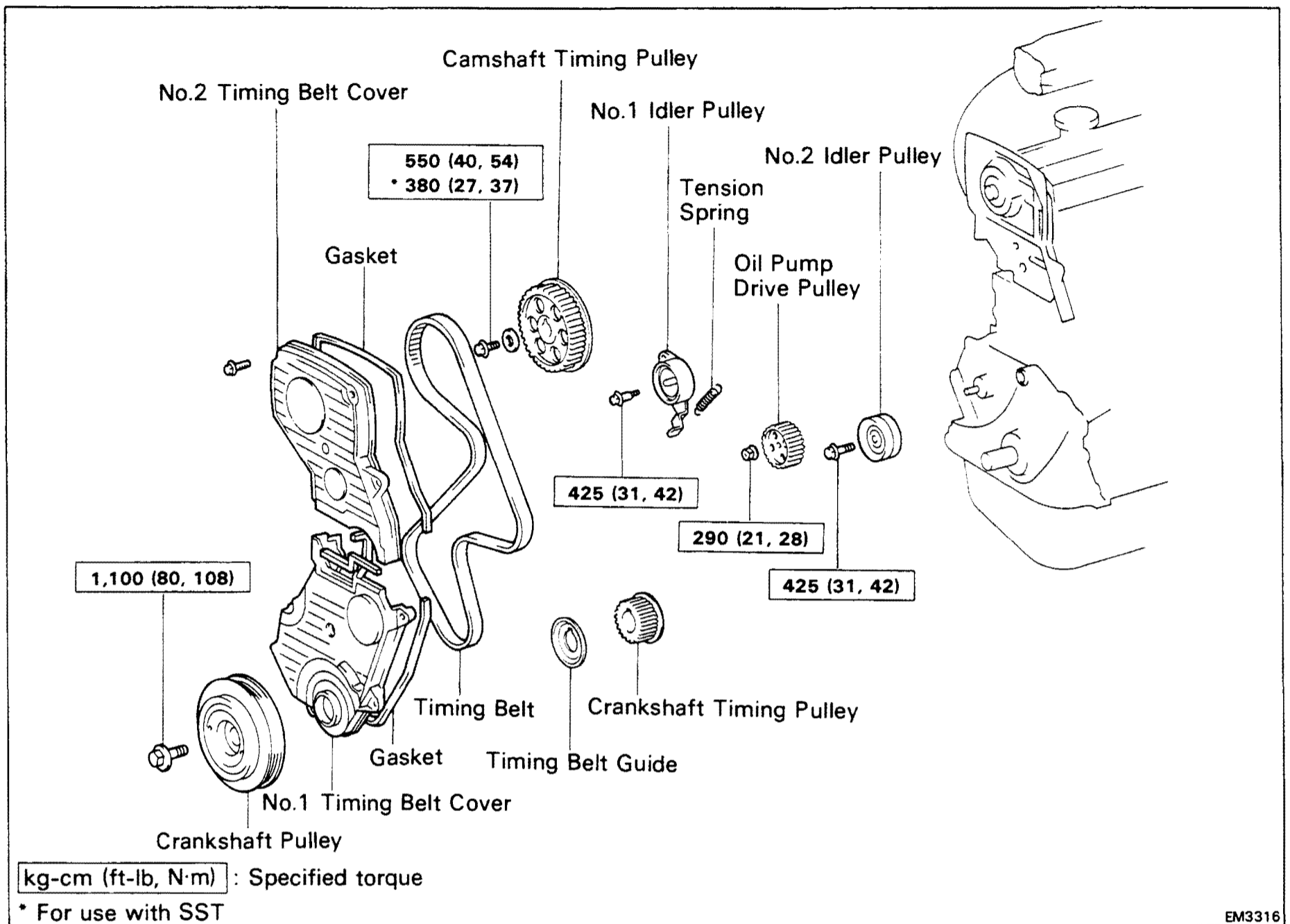

### REMOVAL OF TIMING BELT

1. **REMOVE ALTERNATOR**  
(See step 2 on page EM-65)
2. **REMOVE RH ENGINE MOUNTING BRACKET**  
Remove the three bolts and mounting bracket.
3. **REMOVE SPARK PLUGS**
4. **DISCONNECT ENGINE WIRE FROM ALTERNATOR BRACKET AND ADJUSTING BAR**  
Remove the two bolts, and disconnect the engine wire from the alternator bracket and adjusting bar.

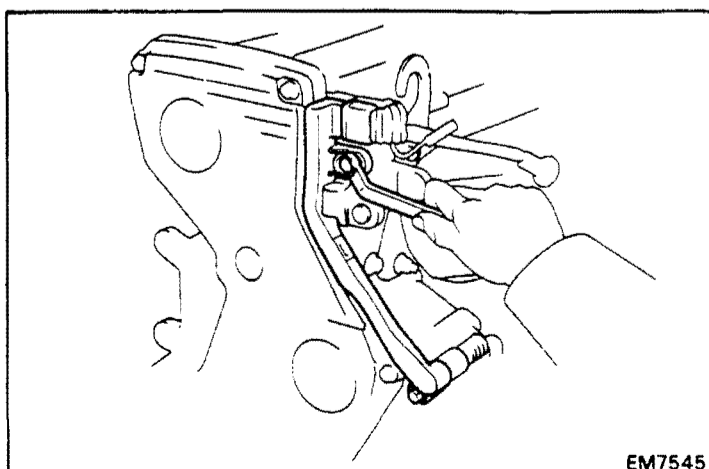

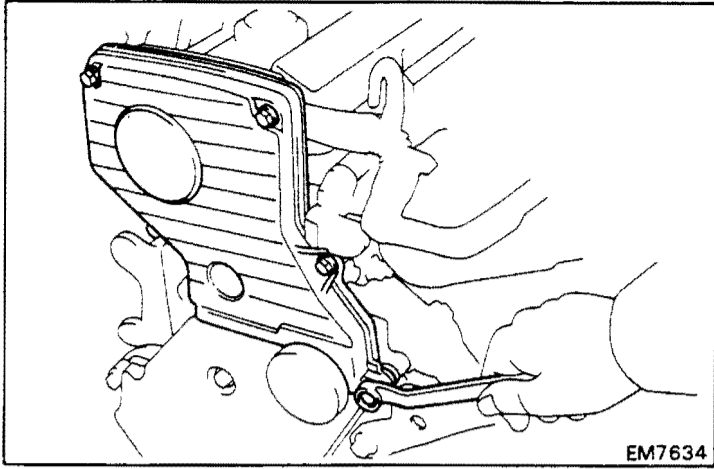

EM7634

### 5. REMOVE NO.2 TIMING BELT COVER

Remove the five bolts, timing belt cover and two gaskets.

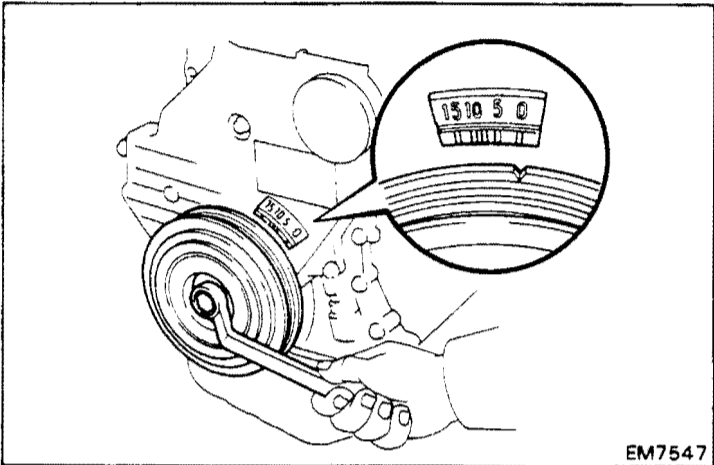

EM7547

### 6. SET NO.1 CYLINDER TO TDC/COMPRESSION

(a) Turn the crankshaft pulley, and align its groove with timing mark "0" of the No.1 timing belt cover.

**NOTICE:** Always turn the crankshaft clockwise.

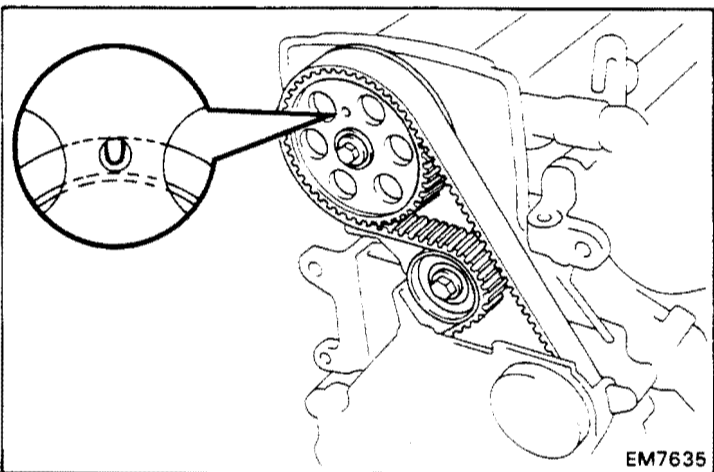

EM7635

(b) Check that the hole of the camshaft timing pulley is aligned with the timing mark of the bearing cap.

If not, turn the crankshaft one revolution (360°).

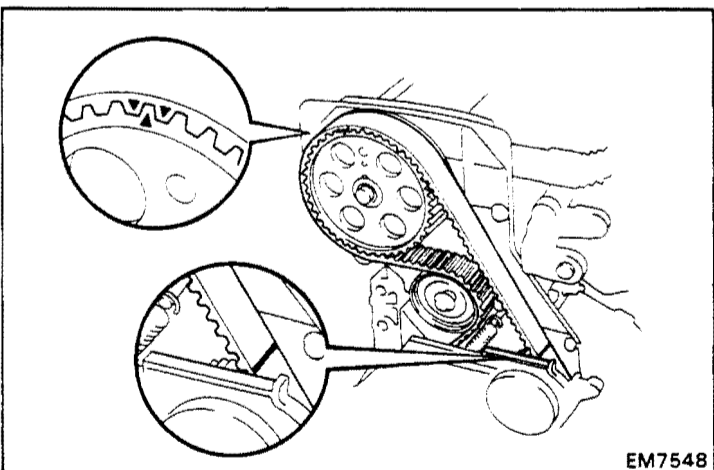

EM7548

### 7. REMOVE TIMING BELT FROM CAMSHAFT TIMING PULLEY

**HINT** (When re-using timing belt): Place matchmarks on the timing belt and camshaft timing pulley, and place a matchmark on the timing belt to match the end of the No.1 timing belt cover.

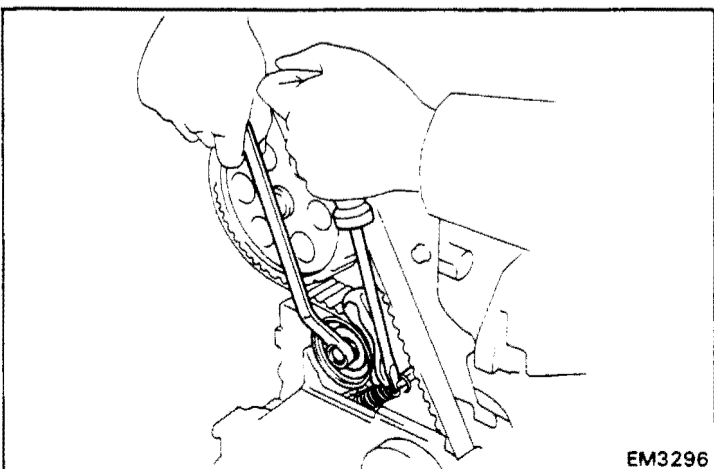

EM3296

(a) Loosen the mount bolt of the No.1 idler pulley and shift the pulley toward the left as far as it will go, temporarily tighten it.

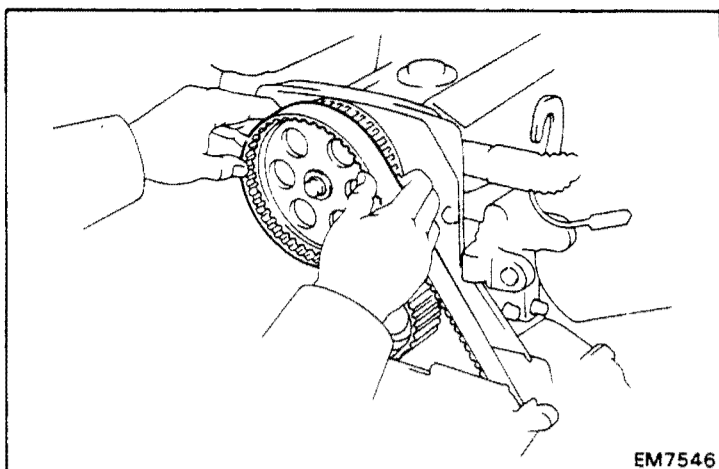

- (b) Remove the timing belt from the camshaft timing pulley.

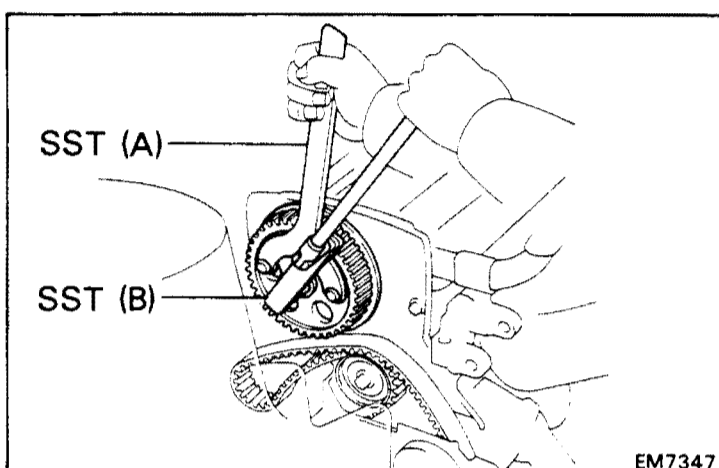

#### 8. REMOVE CAMSHAFT TIMING PULLEY

Using SST, remove the bolt, plate washer and timing pulley.

SST 09278-54012 (A)

HINT (On vehicle): Use SST.

SST 09249-63010 (B)

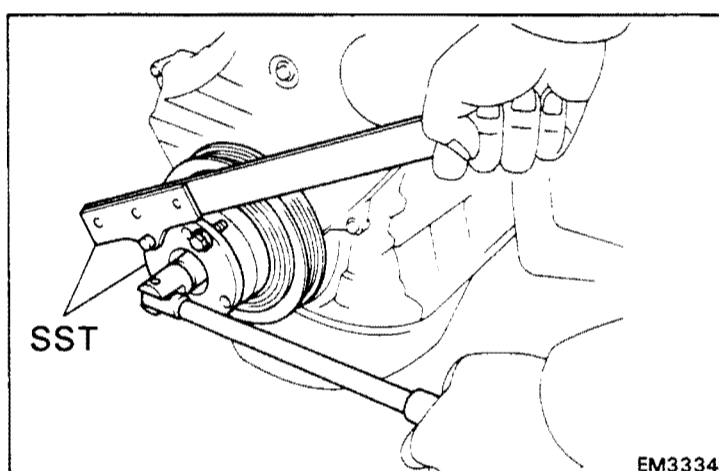

#### 9. REMOVE CRANKSHAFT PULLEY

- (a) Using SST, remove the pulley bolt.

SST 09213-54015 (09214-00030) and 09330-00021

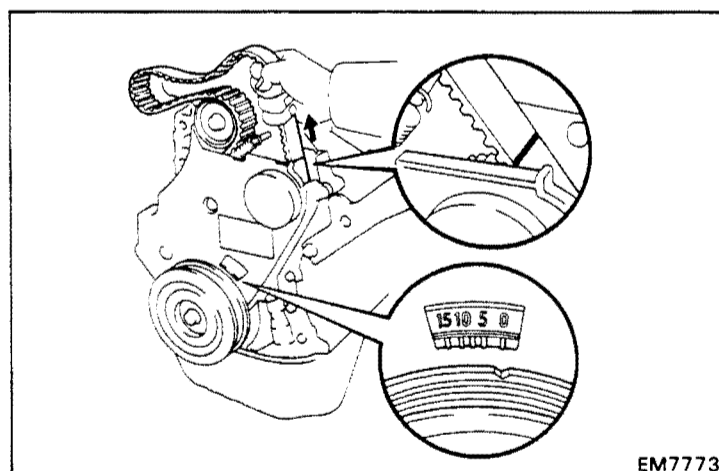

HINT (When re-using timing belt): After loosening the crankshaft pulley bolt, check that the timing belt matchmark aligns with the end of the No.1 timing belt cover when the crankshaft pulley groove is aligned with the timing mark "O" of the No.1 timing belt cover. If the matchmark does not align, align as follows:

(When matchmark is out of alignment clockwise)

- Align the matchmark by pulling the timing belt up on the water pump pulley side while turning the crankshaft pulley counterclockwise.

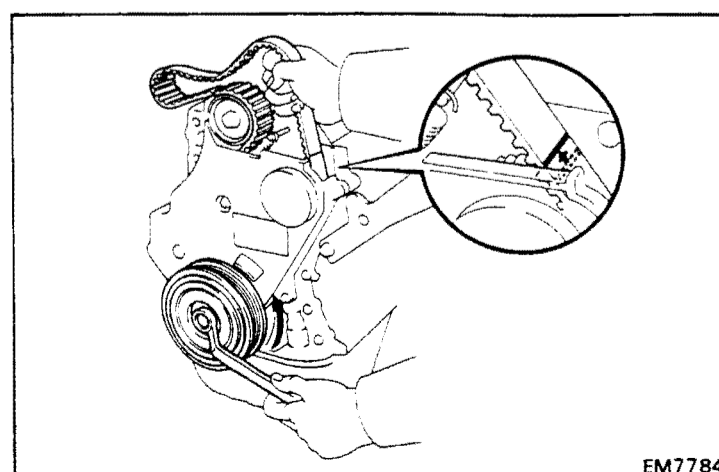

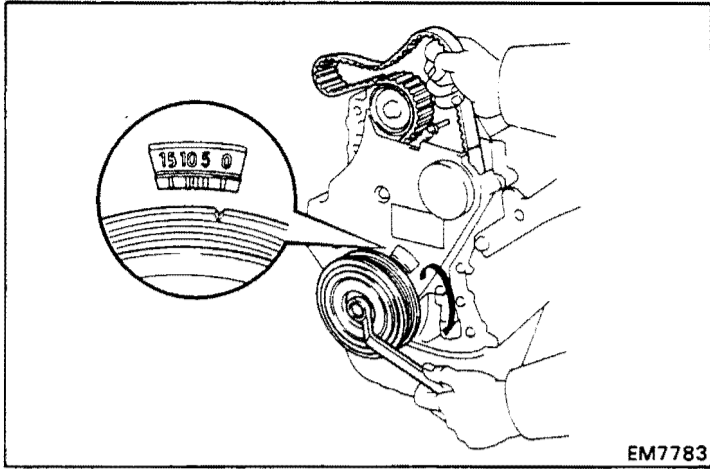

EM7783

- After aligning the matchmark, hold the timing belt. And turn the crankshaft pulley clockwise, and align its groove with timing mark "0" of the No.1 timing belt cover.

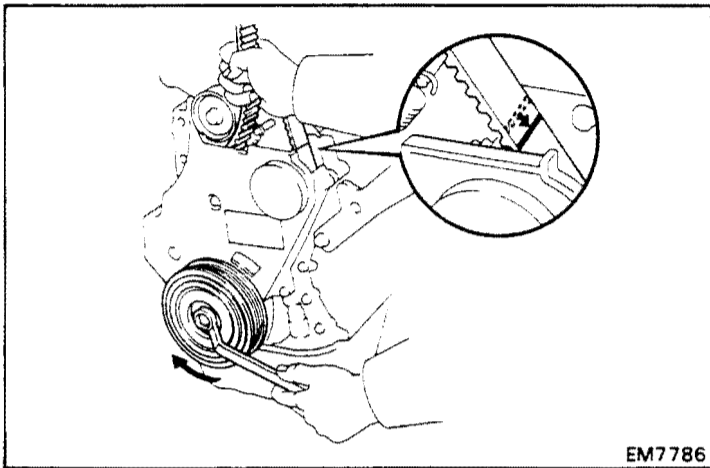

EM7786

(When matchmark is out of alignment counterclockwise)

- Align the matchmark by pulling the timing belt up on the No.1 idler pulley side while turning the crankshaft pulley clockwise.

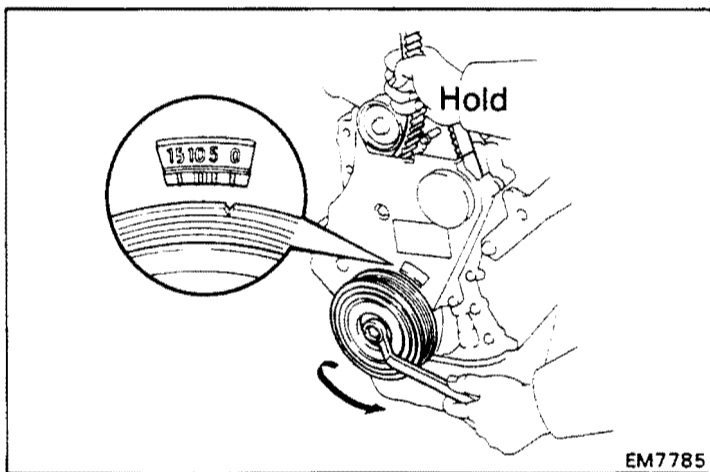

EM7785

- After aligning the matchmark, hold the timing belt. And turn the crankshaft pulley counterclockwise, and align its groove with timing mark "0" of the No.1 timing belt cover.

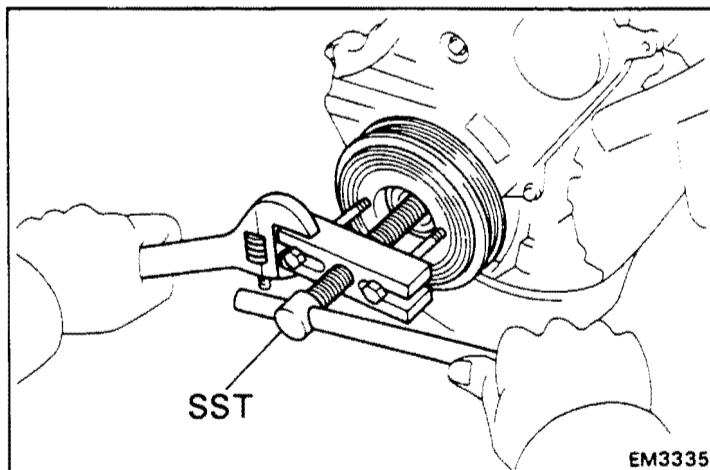

EM3335

(b) Using SST, remove the pulley.

SST 09213-60017 (09213-00020, 09213-00030, 09213-00050)

HINT (When re-using timing belt): Remove the pulley without turning it.

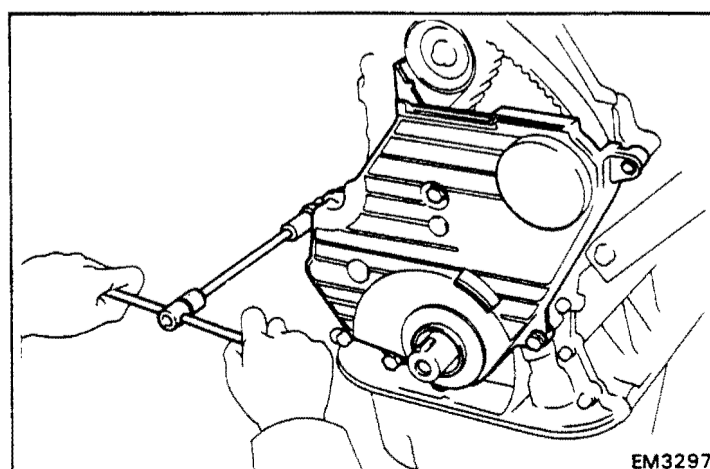

EM3297

## 10. REMOVE NO.1 TIMING BELT COVER

Remove the four bolts, timing belt cover and gasket.

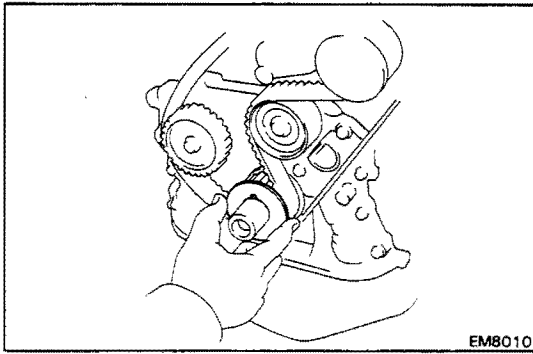
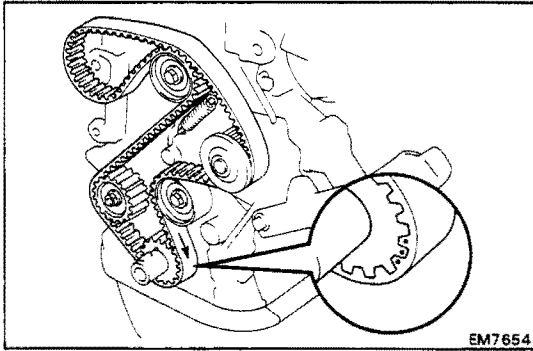
**11. REMOVE TIMING BELT GUIDE****12. REMOVE TIMING BELT**

**HINT** (When re-using timing belt): Draw a direction arrow on the timing belt (in the direction of engine revolution), and place the matchmarks on the timing belt and crankshaft timing pulley.

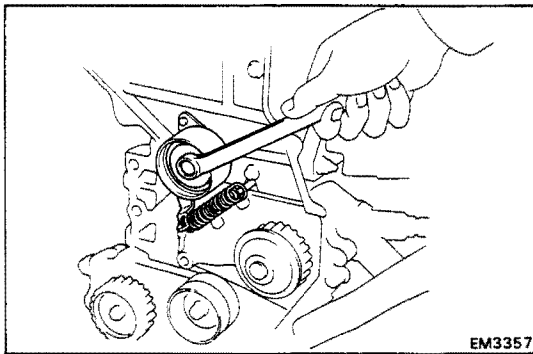
**13. REMOVE NO.1 IDLER PULLEY AND TENSION SPRING**

Remove the bolt, pulley and tension spring.

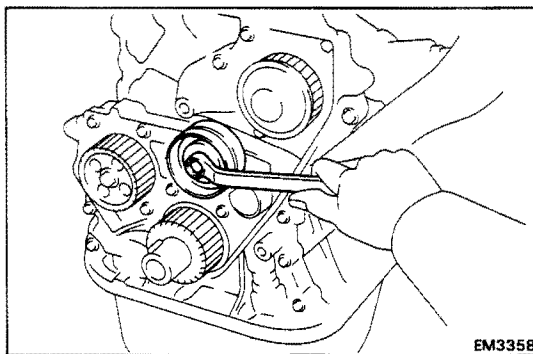
**14. REMOVE NO.2 IDLER PULLEY**

Remove the bolt and pulley.

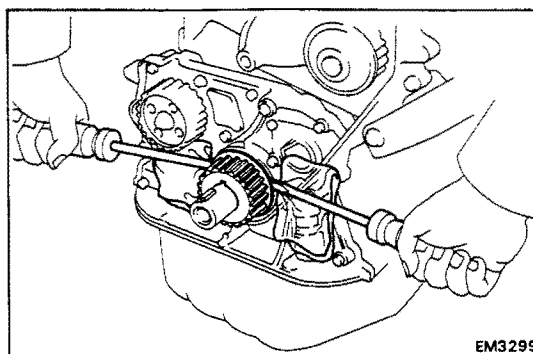
**15. REMOVE CRANKSHAFT TIMING PULLEY**

If the pulley cannot be removed by hand, use two screwdrivers.

**HINT:** Position shop rags as shown to prevent damage.

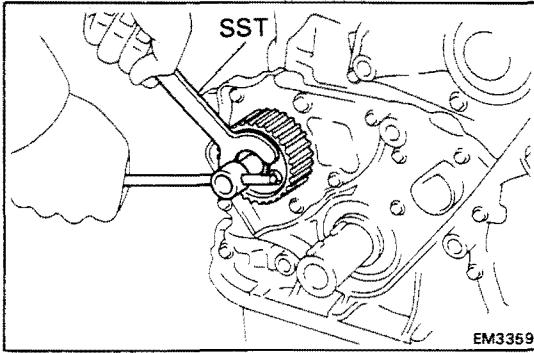

## 16. REMOVE OIL PUMP PULLEY

Using SST, remove the nut and pulley.

SST 09616-30011

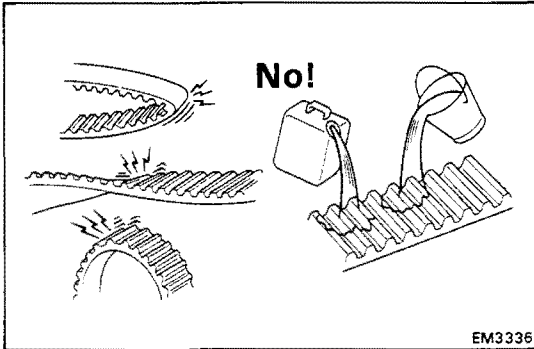

## INSPECTION OF TIMING BELT COMPONENTS

### 1. INSPECT TIMING BELT

#### NOTICE:

- Do not bend, twist or turn the timing belt inside out.
- Do not allow the timing belt to come into contact with oil, water or steam.
- Do not utilize timing belt tension when installing or removing the mount bolt of the camshaft timing pulley.

If there are any defects as shown in the illustrations, check the following points:

- (a) Premature parting
  - Check for proper installation.
  - Check the timing cover gasket for damage and proper installation.
  
- (b) If the belt teeth are cracked or damaged, check to see if either the camshaft or water pump is locked.
  
- (c) If there is noticeable wear or cracks on the belt face, check to see if there are nicks on the side of the idler pulley lock.

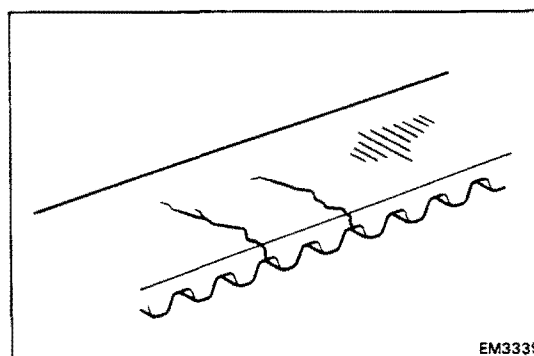
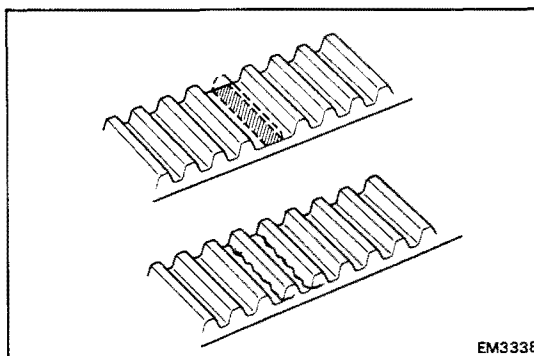
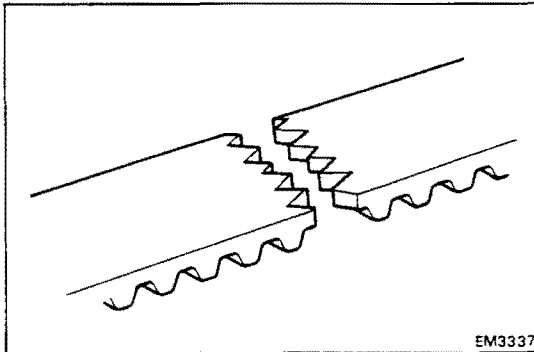

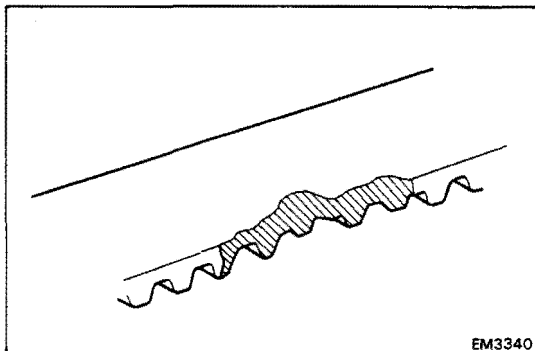

- (d) If there is wear or damage on only one side of the belt, check the belt guide and the alignment of each pulley.

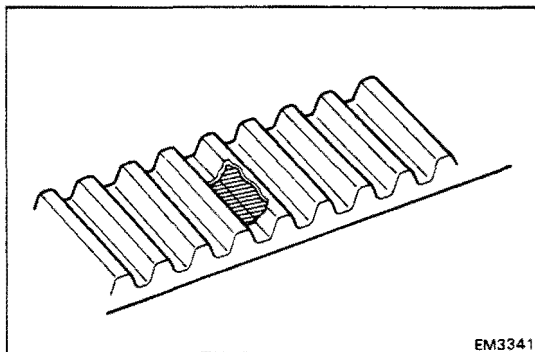

- (e) If there is noticeable wear on the belt teeth, check the timing cover to damage and check the correct gasket installation and the foreign material on the pulley teeth.

If necessary, replace the timing belt.

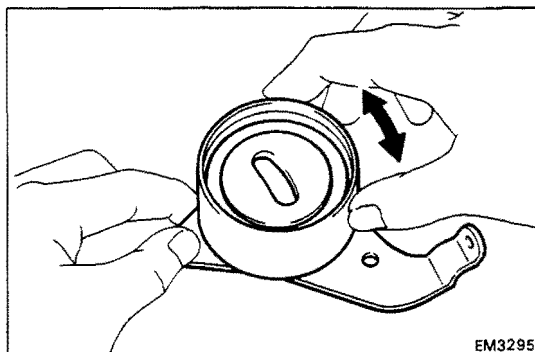

## 2. INSPECT IDLER PULLEYS

Check the turning smoothness of the idler pulley.

If necessary, replace the idler pulley.

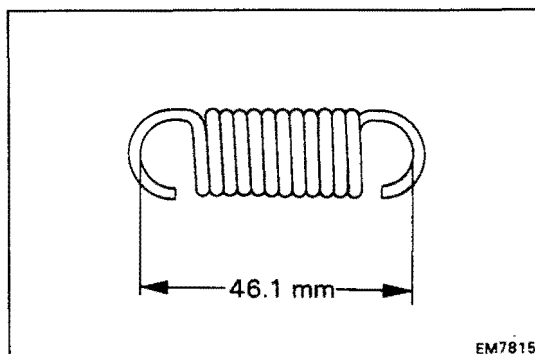

## 3. INSPECT TENSION SPRING

- (a) Measure the free length of tension spring.

**Free length: 46.1 mm (1.815 in.)**

If the free length is not as specified, replace the tension spring.

- (b) Measure the tension of the tension spring at the specified installed length.

**Installed tension:**

**6.0 – 7.0 kg (13.2 – 15.4 lb, 59 – 69 N·m)  
at 50.5 mm (1.988 in.)**

If the installed tension is not as specified, replace the tension spring.



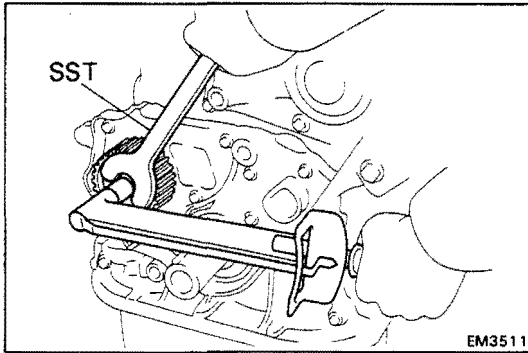

## INSTALLATION OF TIMING BELT

(See page EM-33)

### 1. INSTALL OIL PUMP PULLEY

(a) Align the cutouts of the pulley and shaft, and slide on the pulley.

(b) Using SST, install the nut.

SST 09616-30011

**Torque:** 290 kg-cm (21 ft-lb, 28 N·m)

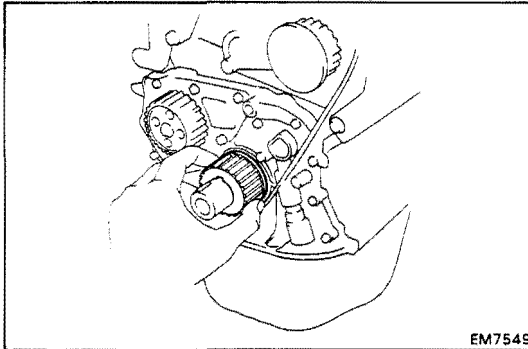

### 2. INSTALL CRANKSHAFT TIMING PULLEY

(a) Align the timing pulley set key with the key groove of the pulley.

(b) Slide on the timing pulley, facing the flange side inward.

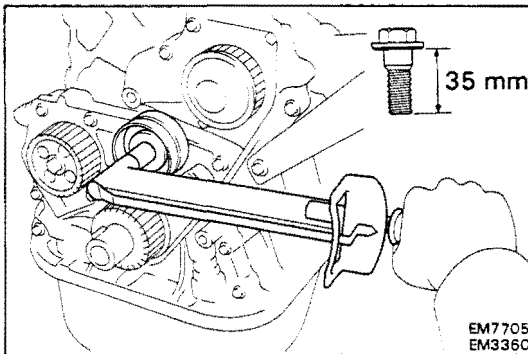

### 3. INSTALL NO.2 IDLER PULLEY

(a) Install the pulley with the bolt.

**Torque:** 425 kg-cm (31 ft-lb, 42 N·m)

**HINT:** Use bolt 35 mm (1.38 in.) in length.

(b) Check that the idler pulley moves smoothly.

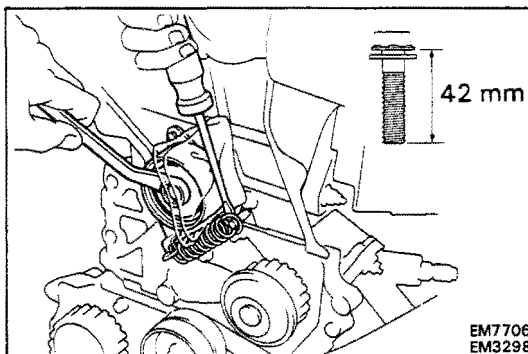

### 4. TEMPORARILY INSTALL NO.1 IDLER PULLEY AND TENSION SPRING

(a) Install the pulley with the bolt. Do not tighten the bolt yet.

**HINT:** Use bolt 42 mm (1.65 in.) in length.

(b) Install the tension spring.

(c) Pry the pulley toward the left as far as it will go and tighten the bolt.

(d) Check that the idler pulley moves smoothly.

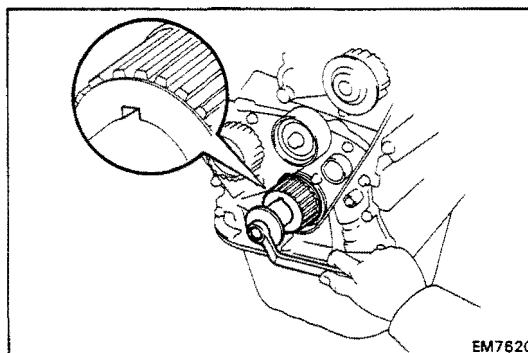

### 5. TEMPORARILY INSTALL TIMING BELT

**NOTICE:** The engine should be cold.

(a) Using the crankshaft pulley bolt, turn the crankshaft and position the key groove of the crankshaft timing pulley upward.

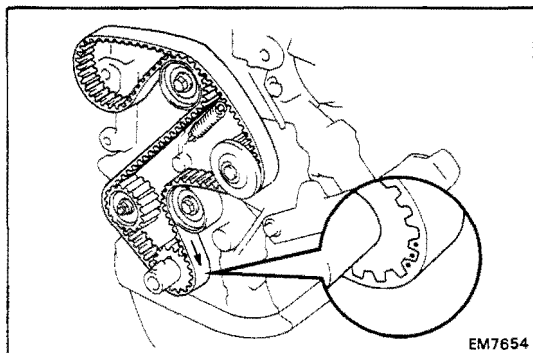

- (b) Remove any oil or water on the crankshaft pulley, oil pump pulley, water pump pulley, No.1 idler pulley, No.2 idler pulley, and keep them clean.
- (c) Install the timing belt on the crankshaft timing, oil pump pulley, No.2 idler pulley, water pump pulley and No.2 idler pulley.

**HINT** (When re-using timing belt): Align the matchmarks of the crankshaft timing pulley and timing belt, and install the belt with the arrow pointing in the direction of engine revolution.

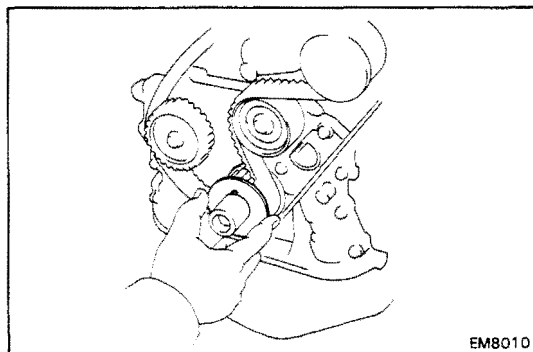

## 6. INSTALL TIMING BELT GUIDE

Install the guide, facing the cup side outward.

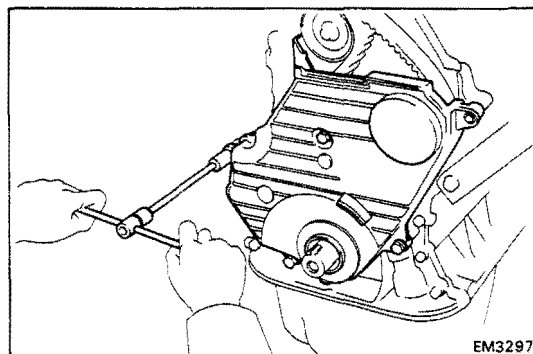

## 7. INSTALL NO.1 TIMING BELT COVER

- (a) Install the gasket to the timing belt cover.
- (b) Install the timing belt cover with the four bolts.

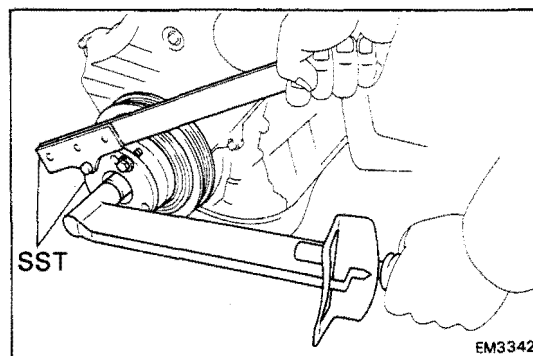

## 8. INSTALL CRANKSHAFT PULLEY

- (a) Align the pulley set key with the key groove of the pulley, and slide on the pulley.
  - (b) Using SST, install the pulley bolt.
- SST 09213-54015 (09214-00030) and 09330-00021  
 Torque: 1,100 kg-cm (80 ft-lb, 108 N·m)

## 9. INSTALL CAMSHAFT TIMING PULLEY

- (a) Align the camshaft knock pin with the knock pin groove of the pulley, and slide on the timing pulley.
- (b) Using SST, install the plate washer and bolt.

SST 09278-54012 (A)

Torque: 550 kg-cm (40 ft-lb, 54 N·m)  
 380 kg-cm (27 ft-lb, 37 N·m) for SST

**HINT** (On vehicle):

- Use SST.
- SST 09249-63010 (B)
- Use a torque wrench with a fulcrum length of 340 mm (13.39 in.).

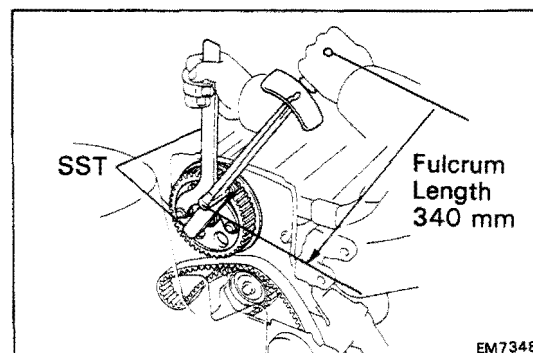

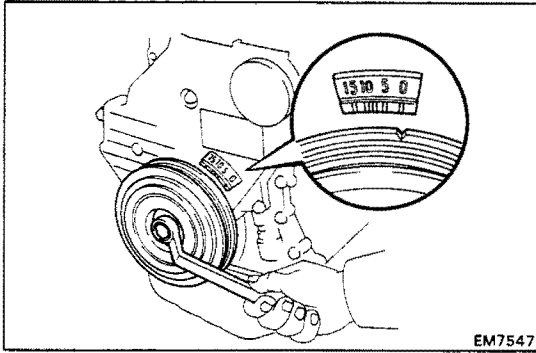
**10. SET NO.1 CYLINDER TO TDC/COMPRESSION**

- (a) Turn the crankshaft pulley, and align its groove with timing mark "0" of the No.1 timing belt cover.

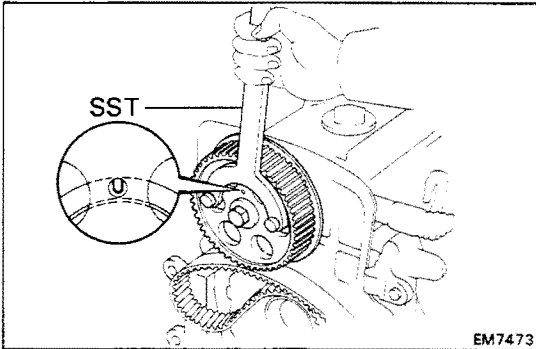

- (b) Using SST, turn the camshaft, and align the hole of the camshaft timing pulley with the timing mark of the bearing cap.

SST 09278-54012

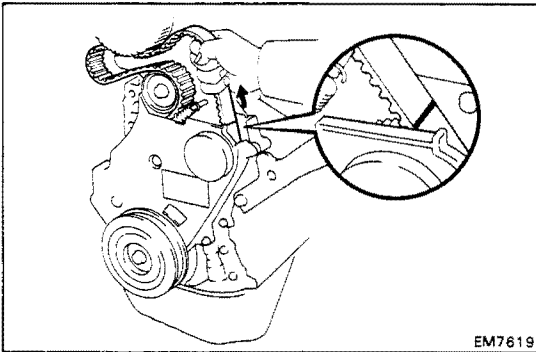
**11. INSTALL TIMING BELT**

HINT (When re-using timing belt):

- Check that the matchmark on the timing belt matches the end of the No.1 timing belt cover.

If the matchmark does not align, shift the meshing of the timing belt and crankshaft timing pulley until they align. (See page EM-41)

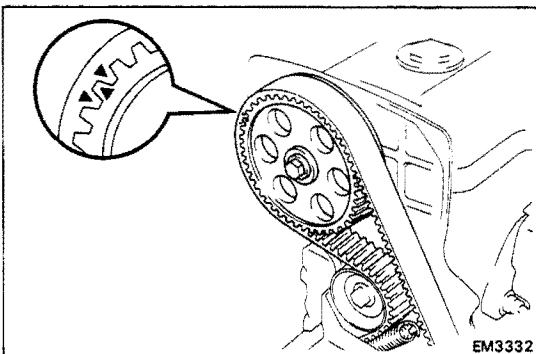

- Align the matchmarks of the timing belt and camshaft timing pulley.

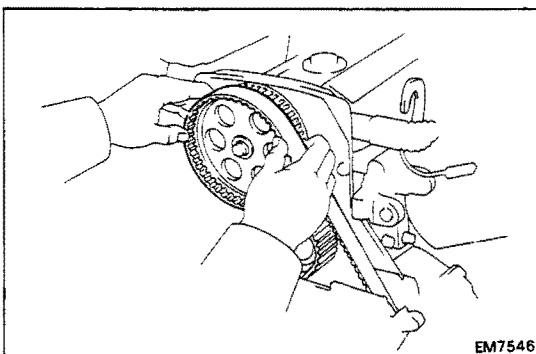

- (a) Remove any oil or water on the camshaft timing pulley, and keep it clean.
- (b) Install the timing belt, insure that there is tension between the crankshaft timing pulley and camshaft timing pulley.

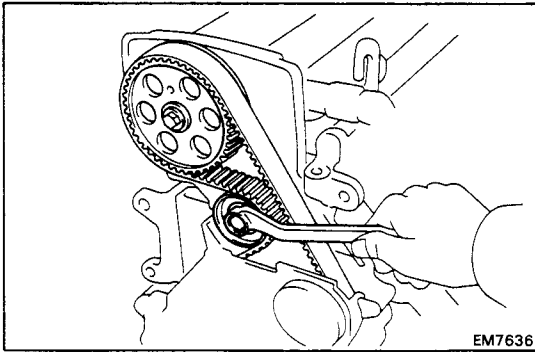

EM7636

**12. CHECK VALVE TIMING**

- (a) Loosen the No.1 idler pulley bolt 1/2 turn.

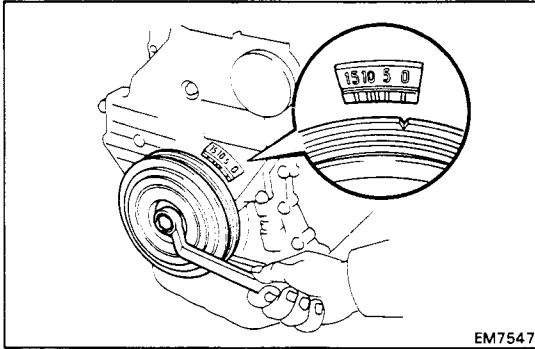

EM7547

- (b) Turn the crankshaft pulley two revolutions from TDC to TDC.

**NOTICE:** Always turn the crankshaft clockwise.

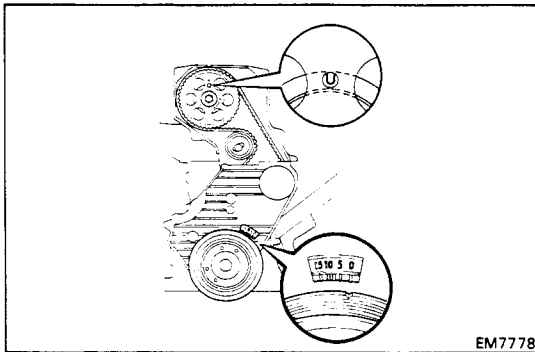

EM7778

- (c) Check that each pulley aligns with the timing marks as shown in the figure.

If the timing marks do not align, remove the timing belt and reinstall it.

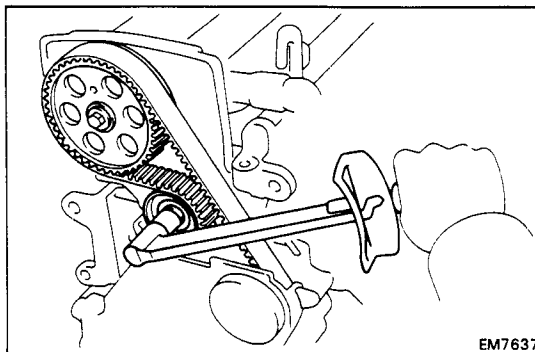

EM7637

- (d) Torque the mount bolt of the No.1 idler pulley.

**Torque:** 425 kg-cm (31 ft-lb, 42 N·m)

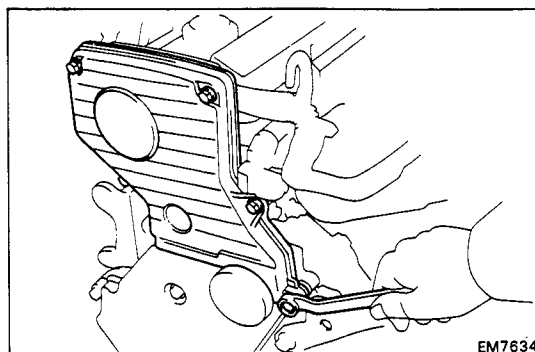

EM7634

**13. INSTALL NO.2 TIMING BELT COVER**

- (a) Install the two gaskets to the No.1 and No.2 belt covers.  
 (b) Install the belt cover with the five bolts.

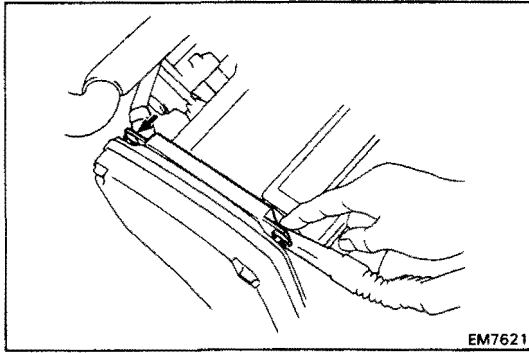

(c) Install the two clamps of the engine wire to each bolt.

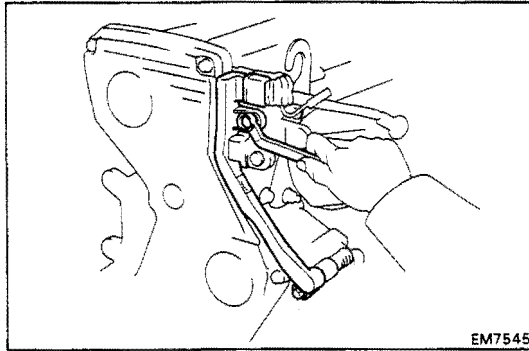

**14. INSTALL ENGINE WIRE TO ALTERNATOR BRACKET AND ADJUSTING BAR**

Install the engine wire with the two bolts.

**15. INSTALL SPARK PLUGS**

Torque: 180 kg-cm (13 ft-lb, 18 N·m)

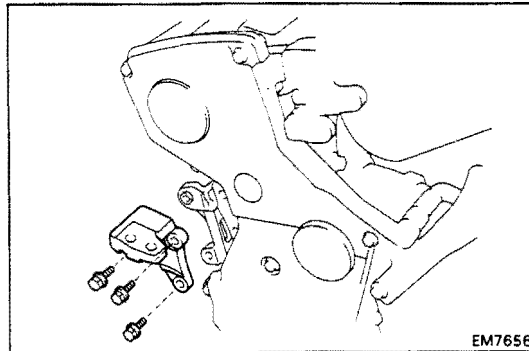

**16. INSTALL RH ENGINE MOUNTING BRACKET**

Install the bracket with the three bolts.

Torque: 530 kg-cm (38 ft-lb, 52 N·m)

**17. INSTALL ALTERNATOR**  
(See step 28 on page EM-96)

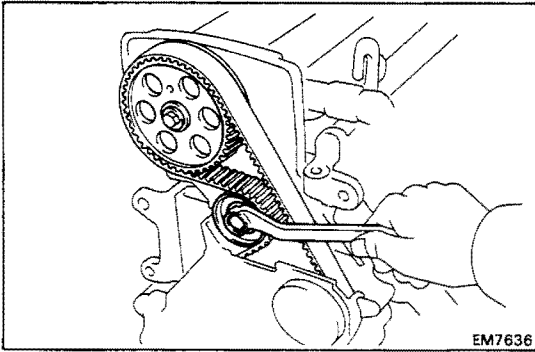
**12. CHECK VALVE TIMING**

- (a) Loosen the No.1 idler pulley bolt 1/2 turn.

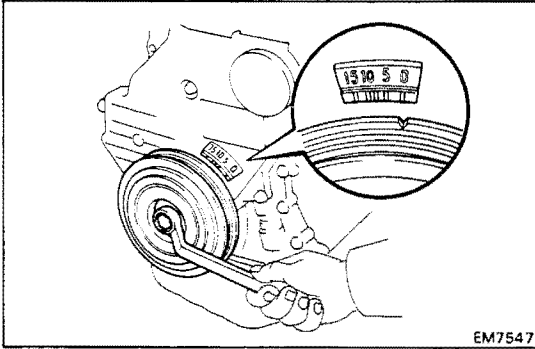

- (b) Turn the crankshaft pulley two revolutions from TDC to TDC.

**NOTICE:** Always turn the crankshaft clockwise.

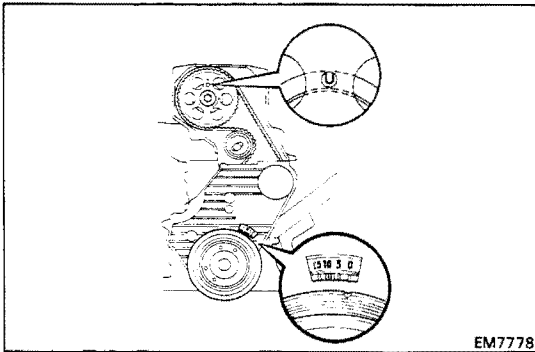

- (c) Check that each pulley aligns with the timing marks as shown in the figure.

If the timing marks do not align, remove the timing belt and reinstall it.

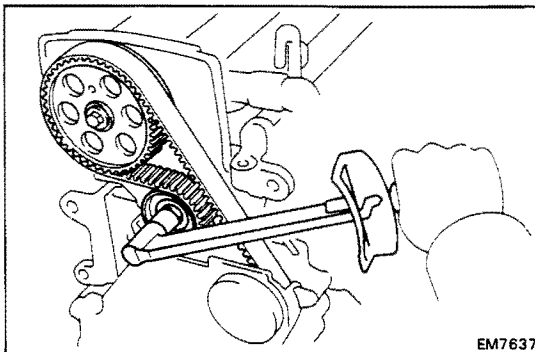

- (d) Torque the mount bolt of the No.1 idler pulley.

**Torque: 425 kg-cm (31 ft-lb, 42 N·m)**

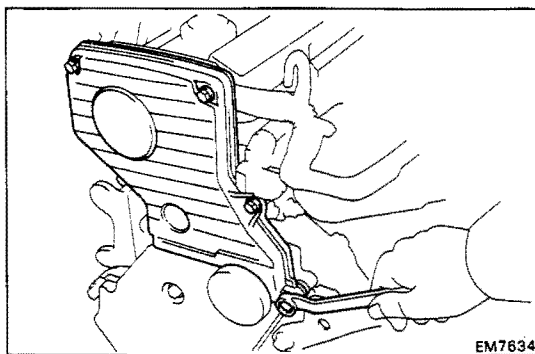
**13. INSTALL NO.2 TIMING BELT COVER**

- (a) Install the two gaskets to the No.1 and No.2 belt covers.  
 (b) Install the belt cover with the five bolts.

## TIMING BELT (3S-GE and 3S-GTE) COMPONENTS

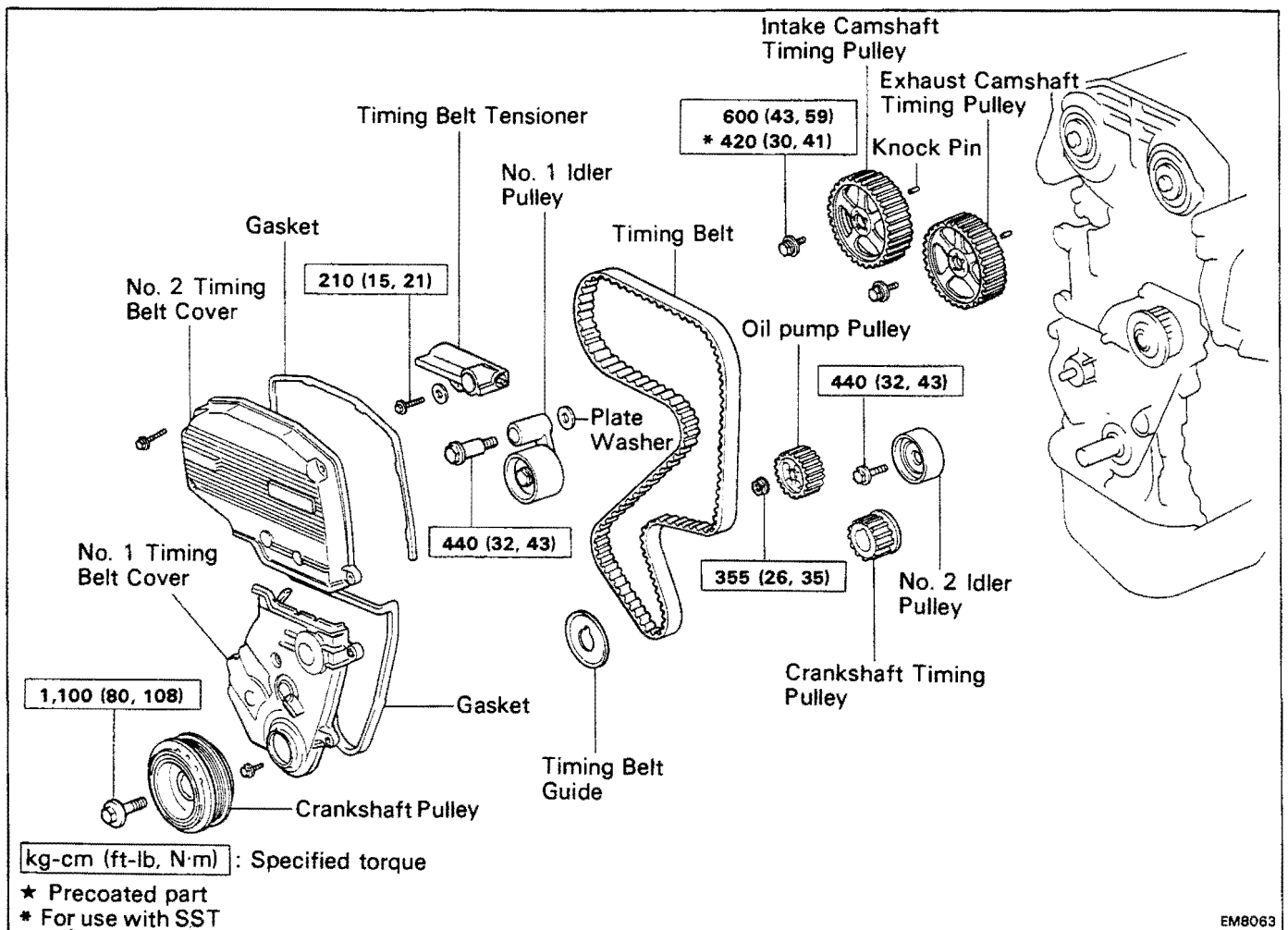

### REMOVAL OF TIMING BELT

1. REMOVE ALTERNATOR  
3S-GE (See step 2 on page EM-101)  
3S-GTE (See step 3 on page EM-108)
2. (3S-GE)  
REMOVE AIR INTAKE CHAMBER  
(See step 13 on page EM-105)
3. (3S-GTE)  
REMOVE INTERCOOLER  
(See steps 4 to 6 on page TC-9)
4. (3S-GTE)  
REMOVE EGR VACUUM MODULATOR  
(See step 13 on page EM-111)
5. (3S-GTE)  
REMOVE EGR VALVE AND PIPE  
(See step 14 on page EM-111)
6. (3S-GTE)  
REMOVE THROTTLE BODY  
(See steps 5 to 10 on pages FI-170 and 171)

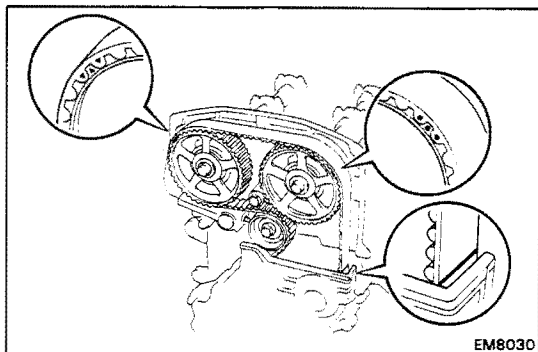

## 12. REMOVE TIMING BELT FROM CAMSHAFT TIMING PULLEYS

### HINT:

- (Re-using timing belt)  
Place matchmarks on the timing belt and camshaft timing pulleys, and place a matchmark on the timing belt to match the end of the No1 timing belt cover.
- (When replacing timing belt tensioner only)  
To avoid meshing of the timing belt and timing pulley, secure one with a string. And place the matchmarks on the timing belt and RH camshaft timing pulley.

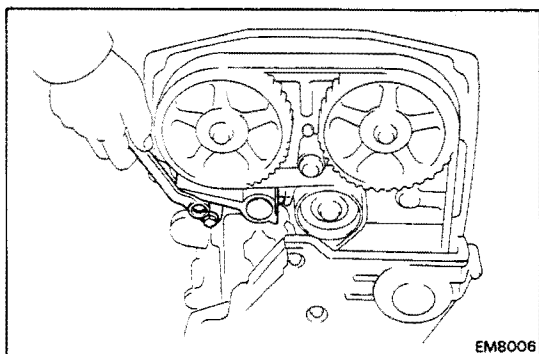
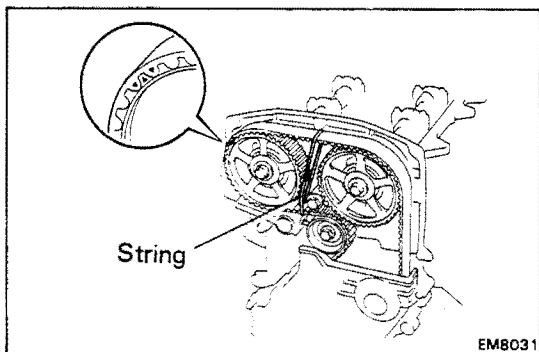

- (a) Remove the two bolts and timing belt tensioner.

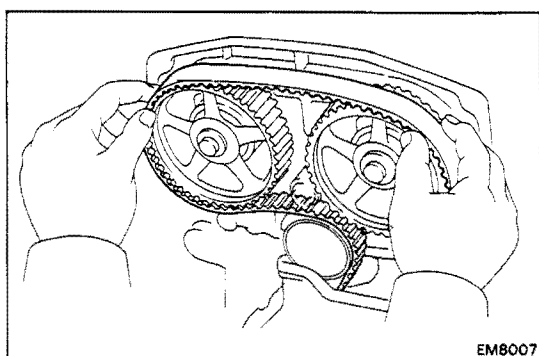

- (b) Remove the timing belt from the camshaft timing pulley.

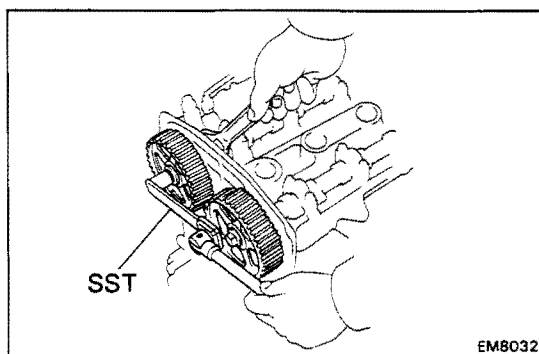

## 13. REMOVE CAMSHAFT TIMING PULLEYS

- (a) Hold the hexagonal wrench head portion of the camshaft with a wrench, and remove the pulley mount bolts.

HINT (On vehicle for intake camshaft timing pulley): Use SST.

SST 09249-63010

- (b) Remove the camshaft pulleys and pins.

HINT: Arrange the intake and exhaust timing pulleys.



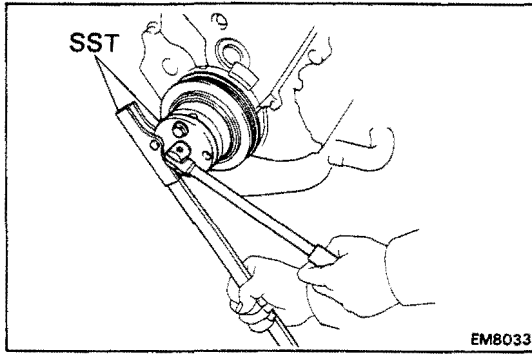

#### 14. REMOVE CRANKSHAFT PULLEY

(a) Using SST, remove the pulley bolt.

SST 09213-54015 (90119-08216) and 09330-00021

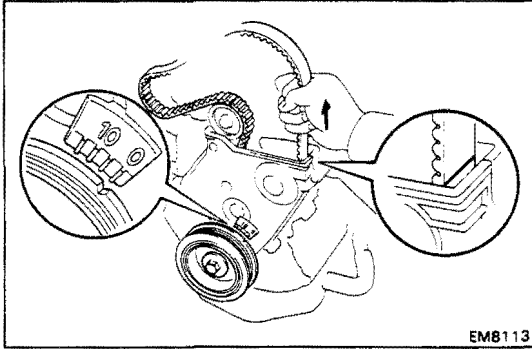

**HINT (When re-using timing belt):** After loosening the crankshaft pulley bolt, check that the timing belt matchmark aligns with the end of the No.1 timing belt cover when the crankshaft pulley groove is aligned with the timing mark "0" of the No.1 timing belt cover. If the matchmark does not align, align as follows:

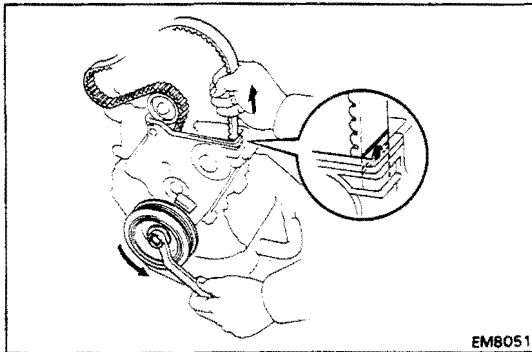

(When matchmark is out of alignment clockwise)

- Align the matchmark by pulling the timing belt up on the water pump pulley side while turning the crankshaft pulley counterclockwise.

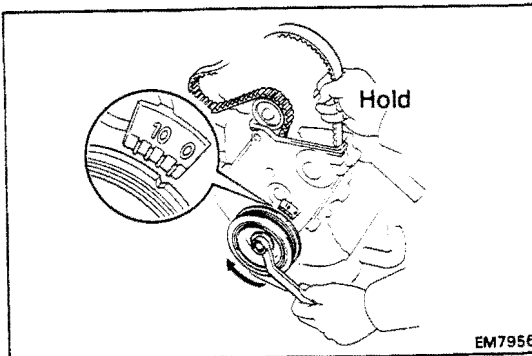

- After aligning the matchmark, hold the timing belt. And turn the crankshaft pulley clockwise, and align its groove with timing mark "0" of the No.1 timing belt cover.

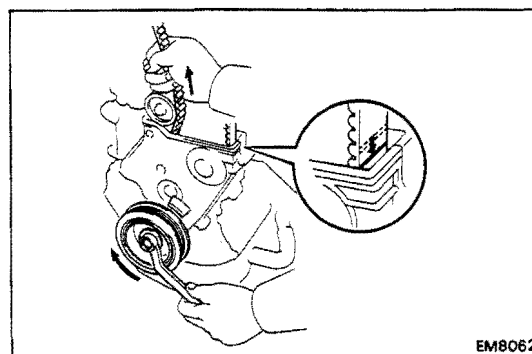

(When matchmark is out of alignment counterclockwise)

- Align the matchmark by pulling the timing belt up on the No.1 idler pulley side while turning the crankshaft pulley clockwise.

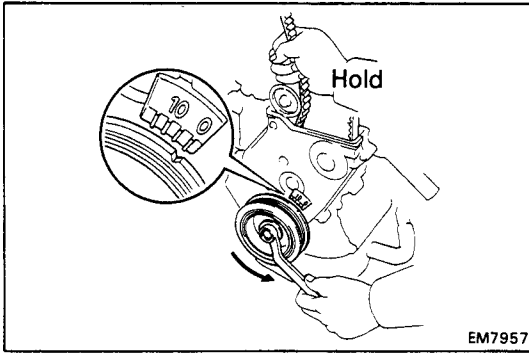

- After aligning the matchmark, hold the timing belt. And turn the crankshaft pulley counterclockwise, and align its groove with timing mark "0" of the No.1 timing belt cover.

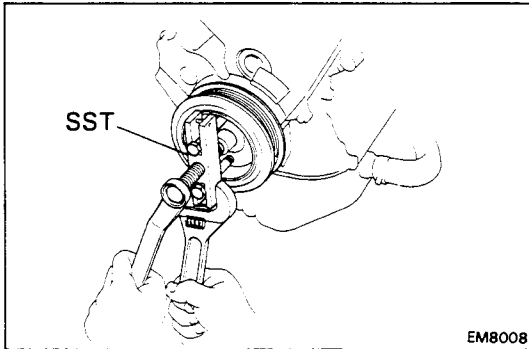

- (b) Using SST, remove the pulley.

SST 09213-31021

HINT (When re-using timing belt): Remove the pulley without turning it.

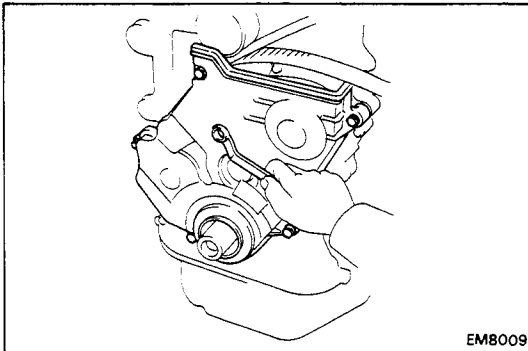

#### 15. REMOVE NO.1 TIMING BELT COVERS

Remove the six bolts, timing belt cover and gasket.

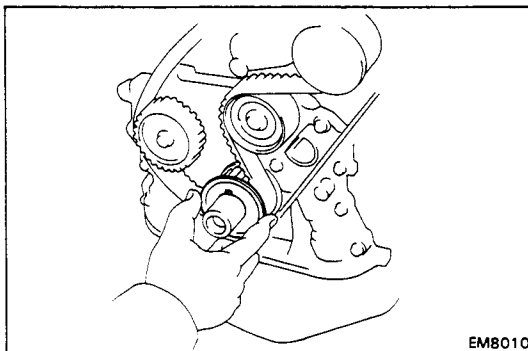

#### 16. REMOVE TIMING BELT GUIDE

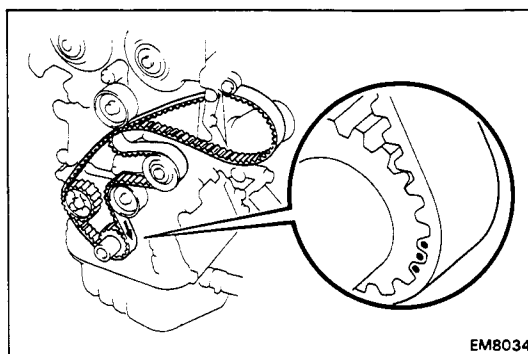

#### 17. REMOVE TIMING BELT

HINT (When re-using timing belt): Draw a direction arrow on the timing belt (in the direction of engine revolution), and place matchmarks on the timing belt and crankshaft timing pulley.

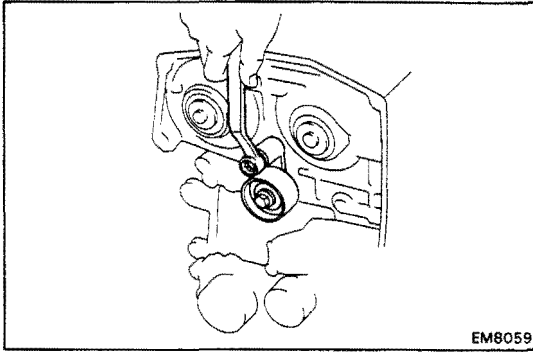
**18. REMOVE NO.1 IDLER PULLEY**

Remove the pivot bolt, pulley and plate washer.

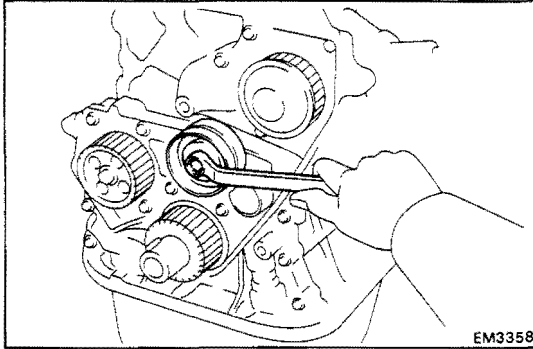
**19. REMOVE NO.2 IDLER PULLEY**

Remove the bolt and pulley.

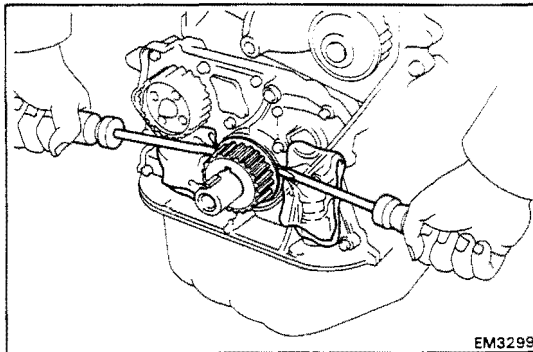
**20. REMOVE CRANKSHAFT TIMING PULLEY**

If the pulley cannot be removed by hand, use two screwdrivers.

HINT: Position shop rags as shown to prevent damage.

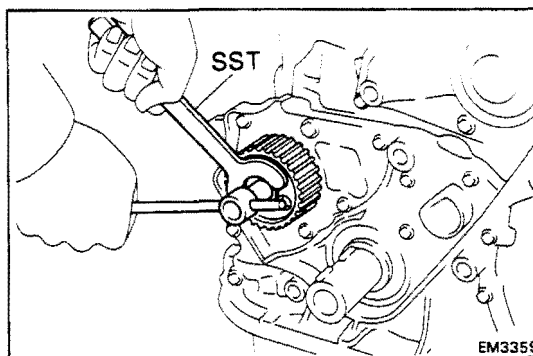
**21. REMOVE OIL PUMP PULLEY**

Using SST, remove the nut and pulley.

SST 09616-30011

**INSPECTION OF TIMING BELT COMPONENTS****1. INSPECT TIMING BELT****NOTICE:**

- Do not bend, twist or turn the timing belt inside out.
- Do not allow the timing belt to come into contact with oil, water or steam.
- Do not utilize timing belt tension when installing or removing the mount bolt of the camshaft timing pulley.

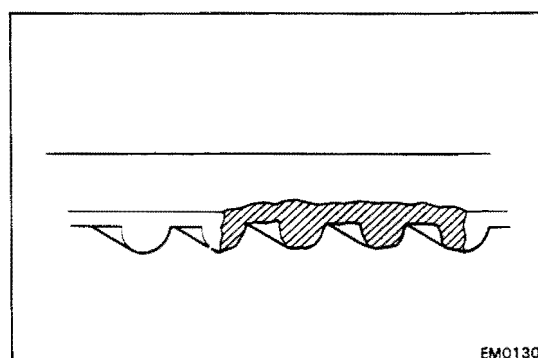
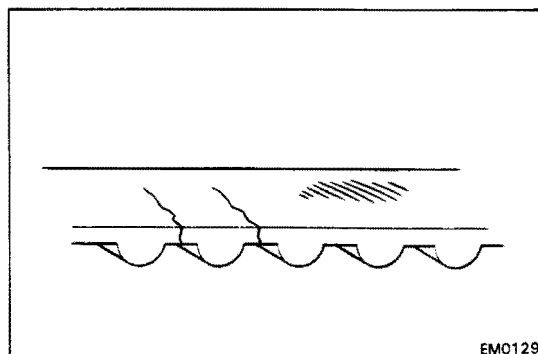
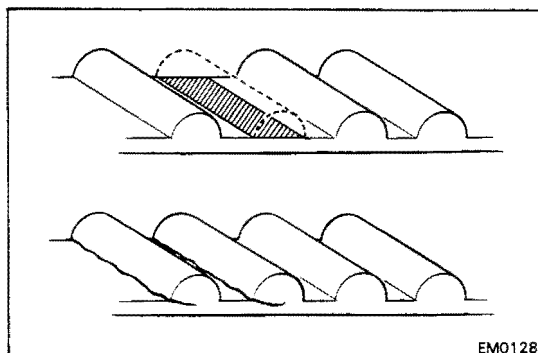
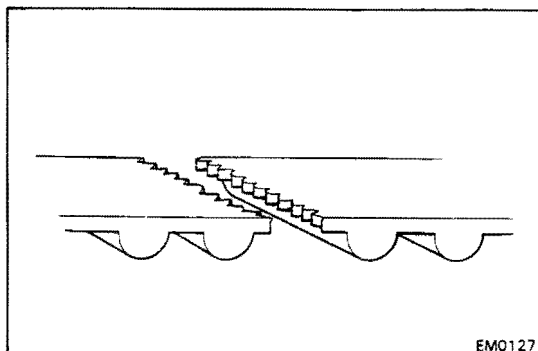
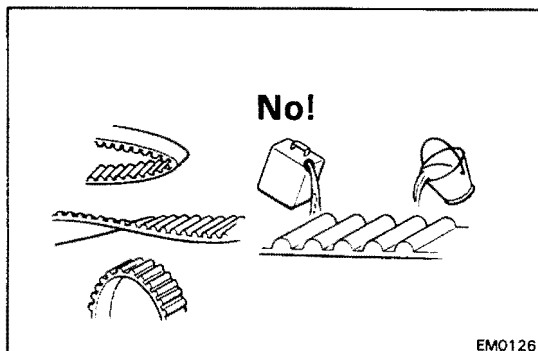

If there are any defects as shown in the illustrations, check for following points:

- (a) Premature parting
  - Check for proper installation.
  - Check the timing cover gasket for damage and proper installation.
- (b) If the belt teeth are cracked or damaged, check to see if either the camshaft or water pump is locked.
- (c) If there is noticeable wear or cracks on the belt face, check to see if there are nicks on the side of the idler pulley lock.
- (d) If there is wear or damage on only one side of the belt, check the belt guide and the alignment of each pulley.

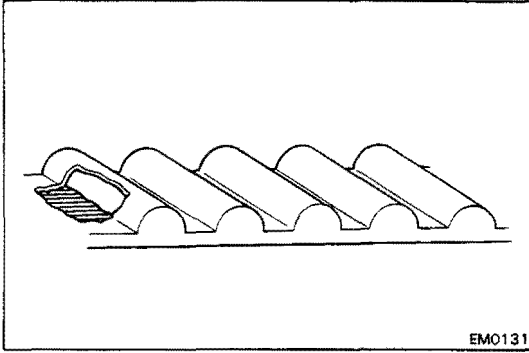

EM0131

- (e) If there is noticeable wear on the belt teeth, check the timing cover for damage, correct gasket installation and the foreign material on the pulley teeth.

If necessary, replace the timing belt.

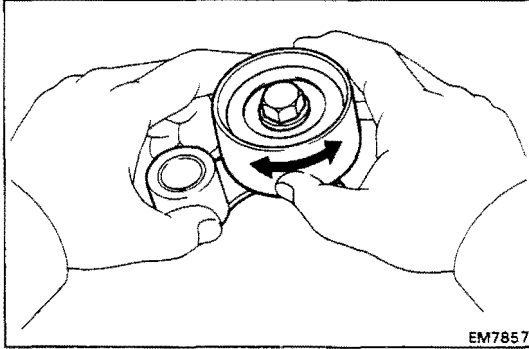

EM7857

## 2. INSPECT IDLER PULLEYS

Check the turning smoothness of the idler pulley.

If necessary, replace the idler pulley.

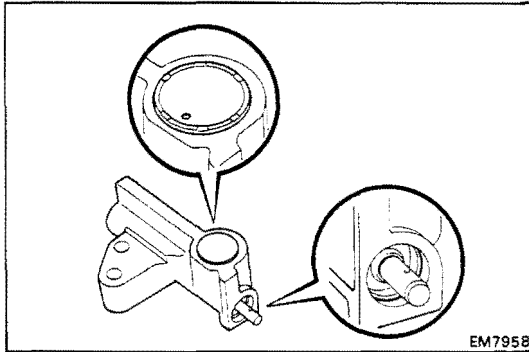

EM7958

## 3. INSPECT TIMING BELT TENSIONER

- (a) Visually check tensioner for oil leakage.

**HINT:** If there is only a small trace of oil on the seal of the push rod, the tensioner is all right.

If leakage is found, replace the tensioner.

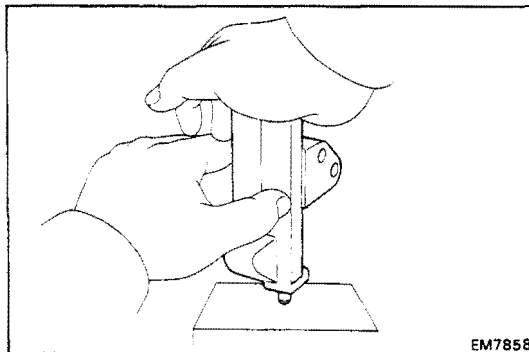

EM7858

- (b) Hold the tensioner with both hands, and push the push rod strongly against the floor or wall to check that it doesn't move.

If the push rod moves, replace the tensioner.

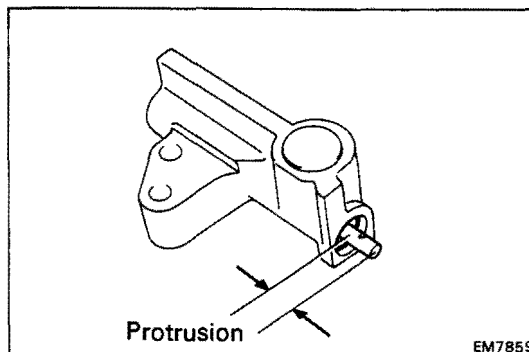

Protrusion

EM7859

- (c) Measure the protrusion of the push rod from the housing end.

**Protrusion: 8.5 – 9.5 mm (0.335 – 0.374 in.)**

If the protrusion is not as specified, replace the tensioner.

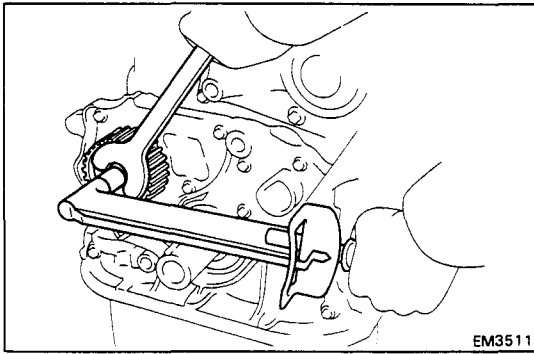

## INSTALLATION OF TIMING BELT

(See page EM-45)

### 1. INSTALL OIL PUMP PULLEY

(a) Align the cutouts of the pulley and shaft, and slide the pulley.

(b) Using SST, install the nut.

SST 09616-30011

**Torque: 355 kg-cm (26 ft-lb, 35 N·m)**

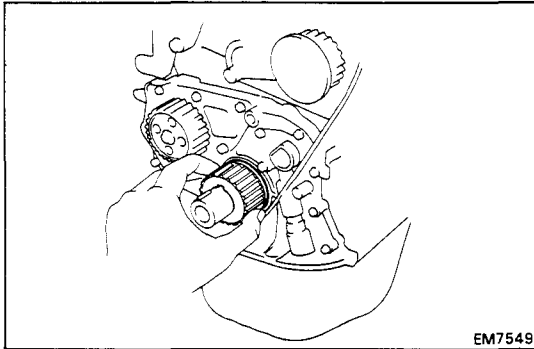

### 2. INSTALL CRANKSHAFT TIMING PULLEY

(a) Align the pulley set key with the key groove of the pulley.

(b) Slide on the timing pulley facing the flange side inward.

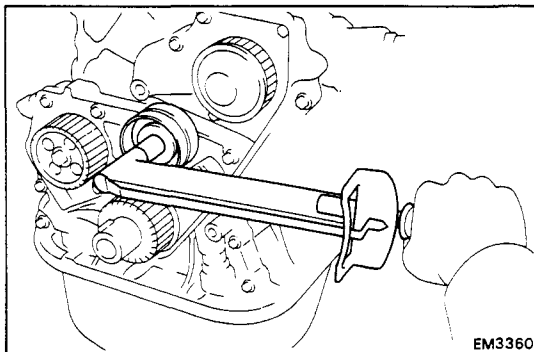

### 3. INSTALL NO.2 IDLER PULLEY

(a) Install the pulley with the bolt.

**Torque: 440 kg-cm (32 ft-lb, 43 N·m)**

(b) Check that the idler pulley moves smoothly.

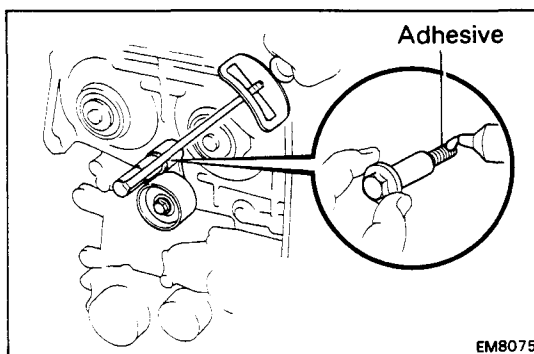

### 4. INSTALL NO.1 IDLER PULLEY

(a) Apply adhesive to two or three threads of the pivot bolt.

**Adhesive: Part No. 08833-00080, THREE BOND 1344, LOCTITE 242 or equivalent**

(b) Install the plate washer and pulley with the pivot bolt.

**Torque: 440 kg-cm (32 ft-lb, 43 N·m)**

(c) Check that the pulley bracket moves smoothly.

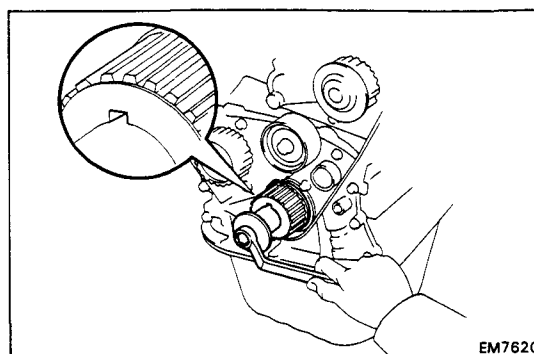

### 5. TEMPORARILY INSTALL TIMING BELT

**NOTICE: The engine should be cold.**

(a) Using the crankshaft pulley bolt, turn the crankshaft and position the key groove of the crankshaft timing pulley upward.

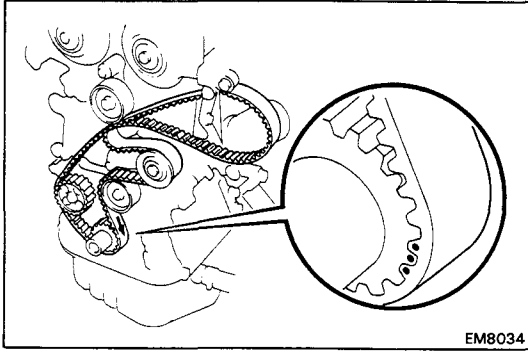

EM8034

- (b) Remove any oil or water on the crankshaft pulley, oil pump pulley, water pump pulley, No.1 idler pulley, No.2 idler pulley, and keep them clean.
- (c) Install the timing belt on the crankshaft timing pulley, oil pump pulley, No.2 idler pulley, water pump pulley and No.1 idler pulley.

**HINT** (When re-using timing belt): Align the matchmarks of the crankshaft timing pulley and timing belt, and install the belt with the arrow pointing in the direction of engine revolution.

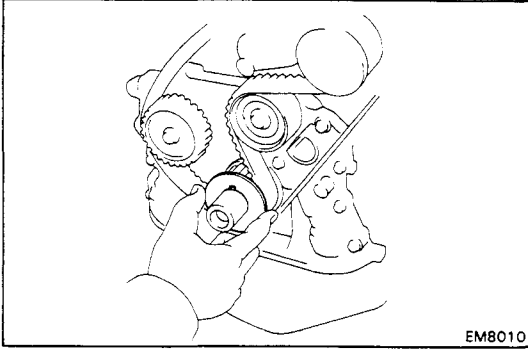

EM8010

#### 6. INSTALL TIMING BELT GUIDE

Install the guide, facing the cup side outward.

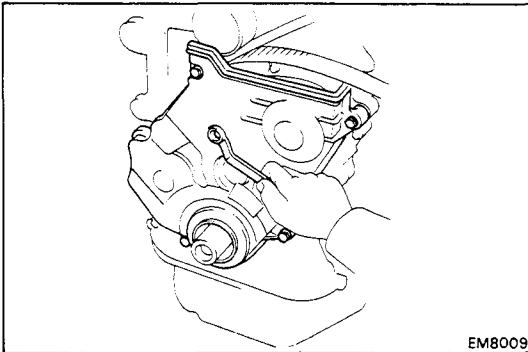

EM8009

#### 7. INSTALL NO.1 TIMING BELT COVER

- (a) Install the gasket to the timing belt cover.
- (b) Install the timing belt cover with the six bolts.

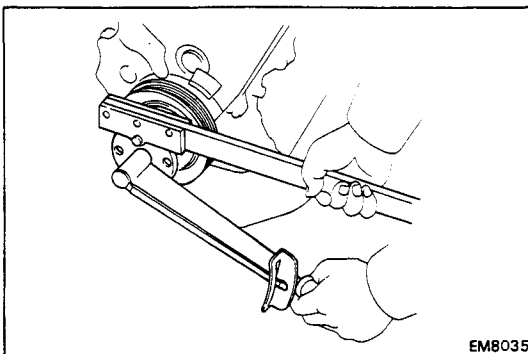

EM8035

#### 8. INSTALL CRANKSHAFT PULLEY

- (a) Align the pulley set key with the key groove of the pulley, and slide on the pulley.
- (b) Using SST, install and torque the bolt.

SST 09213-54015 (90119-08216) and 09330-00021

**Torque:** 1,100 kg-cm (80 ft-lb, 108 N·m)

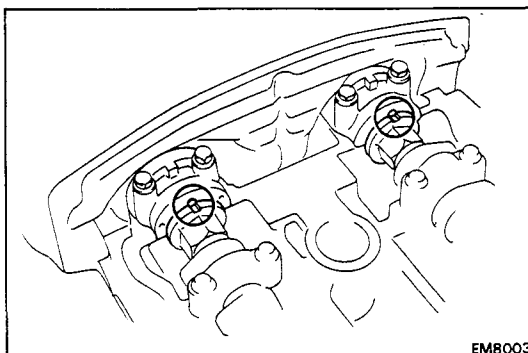

EM8003

#### 9. INSTALL CAMSHAFT TIMING PULLEYS

- (a) Using a wrench, turn and align the groove of the camshaft with the drilled mark of the No.1 camshaft bearing cap.

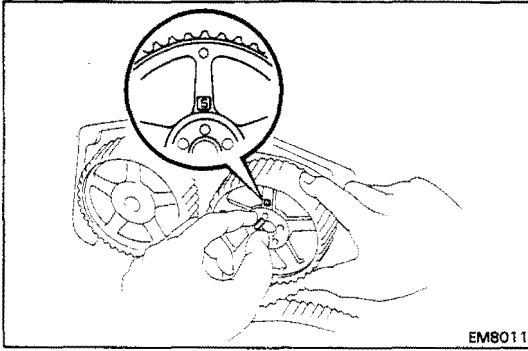

EM8011

- (b) Slide the timing pulley onto the camshaft, facing mark "S" upward.
- (c) Align the pin holes of the camshaft and timing pulley, insert the knock pin.

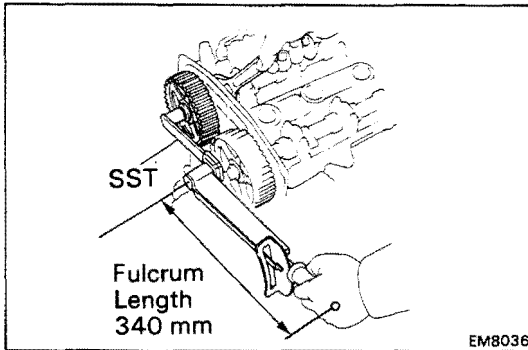

EM8036

- (d) Hold the hexagonal wrench head portion of the camshaft with a wrench, and tighten the bolts.

**Torque:** 600 kg-cm (43 ft-lb, 59 N·m)  
420 kg-cm (30 ft-lb, 41 N·m) for SST

**HINT** (On vehicle for intake camshaft timing pulley):

- Use SST.

SST 09249-63010

- Use a torque wrench with a fulcrum length of 340 mm (13.39 in.).

## 10. SET NO.1 CYLINDER TO TDC/COMPRESSION

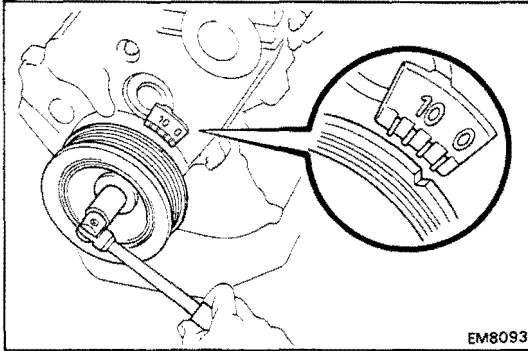

EM8093

- (a) Turn the crankshaft pulley, and align its groove with timing mark "0" of the No.1 timing belt cover.

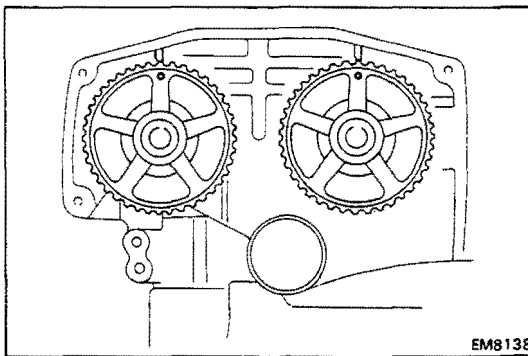

EM8138

- (b) Turn the camshaft, and align the timing marks of the camshaft timing pulleys and No.3 timing belt cover.

## 11. INSTALL TIMING BELT

**HINT** (When re-using timing belt):

- Check that the matchmark on the timing belt matches the end of the No.1 timing belt cover.

If the matchmark does not align, shift the meshing of the timing belt and crankshaft timing pulley until they align. (See page EM-48)

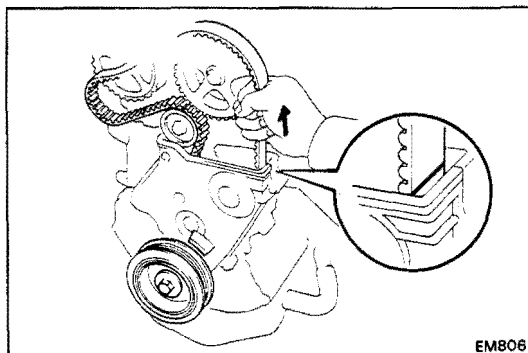

EM8081



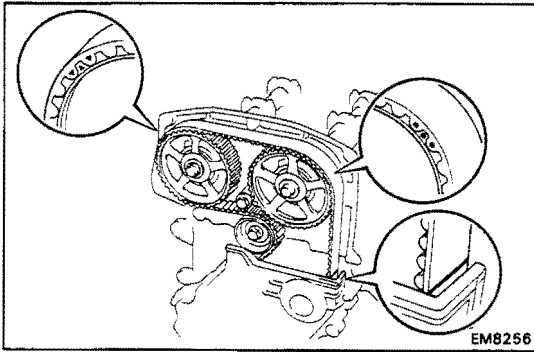

- Align the matchmarks of the timing belt and camshaft timing pulleys.

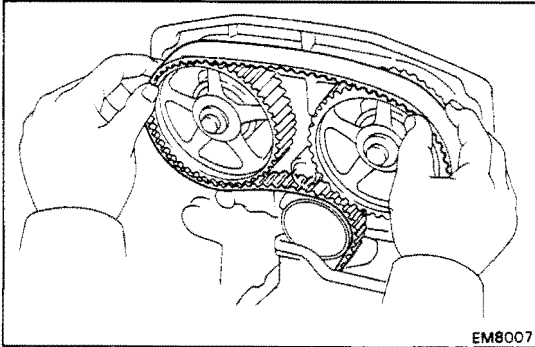

- (a) Remove any oil or water on the camshaft timing pulley, and keep it clean.
- (b) Install the timing belt, insure that there is tension between the crankshaft timing pulley and intake camshaft timing pulley.

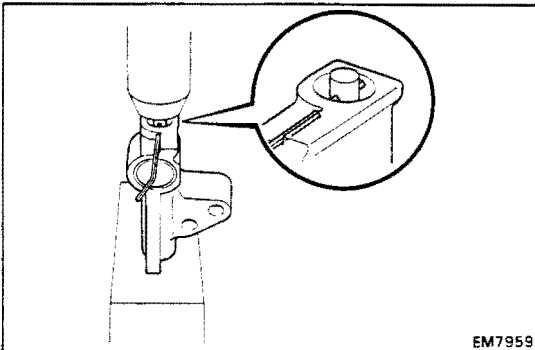

## 12. SET TIMING BELT TENSIONER

- (a) Using a press, slowly press in the push rod using 100 – 1,000 kg (220 – 2,205 lb, 981 – 9,807 N) of pressure.
- (b) Align the holes of the push rod and housing, pass a 1.27 mm hexagon wrench through the holes to keep the setting position of the push rod.
- (c) Release the press.

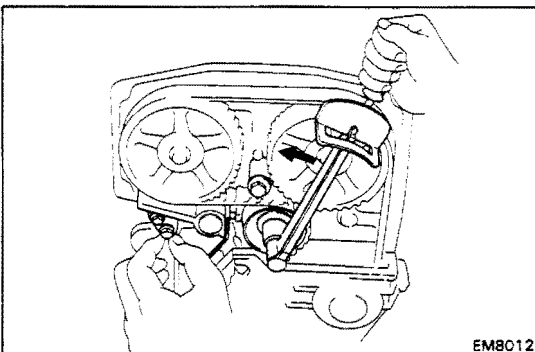

## 13. INSTALL TIMING BELT TENSIONER

- (a) Turn the No.1 idler pulley bolt counterclockwise obtain the specified torque toward the left as far as the No.1 idler pulley will go, and temporarily install the tensioner with the two bolts.

**Torque: 180 kg-cm (13ft-lb, 18 N·m)**

**NOTICE:** To apply the correct torque, apply the torque wrench along the axis through the bolts of the No.1 idler pulley and exhaust camshaft timing pulley.

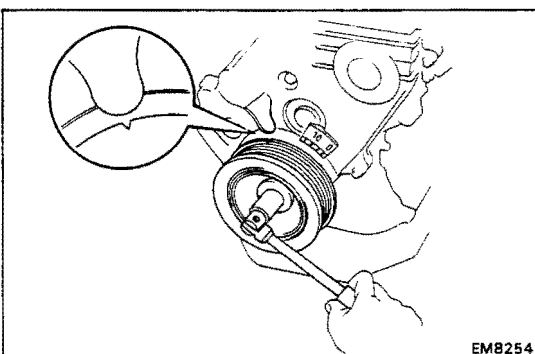

- (b) Slowly turn the crankshaft pulley 5/6 revolution, and align its groove with the ATDC 60° mark of the No.1 timing belt cover.

**NOTICE:** Always turn the crankshaft clockwise.

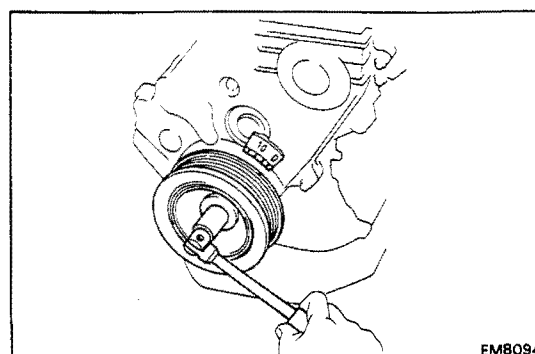
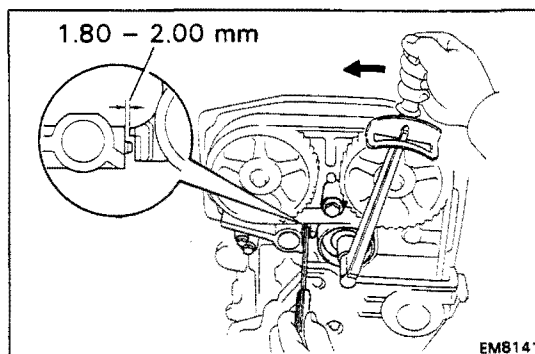
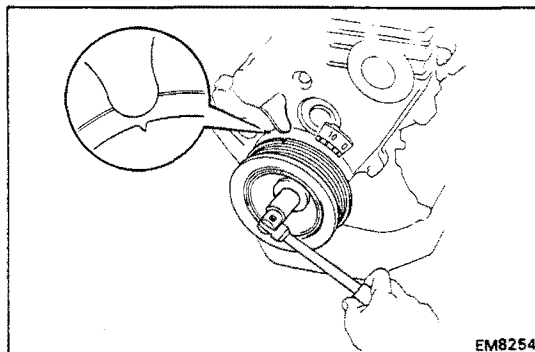
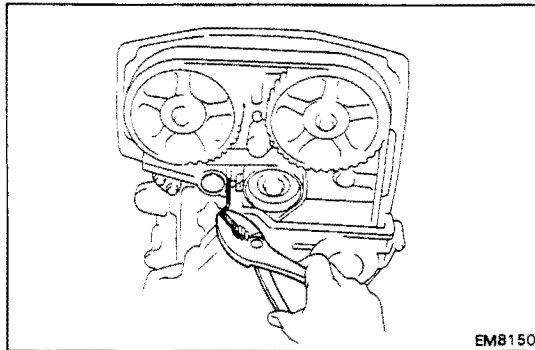
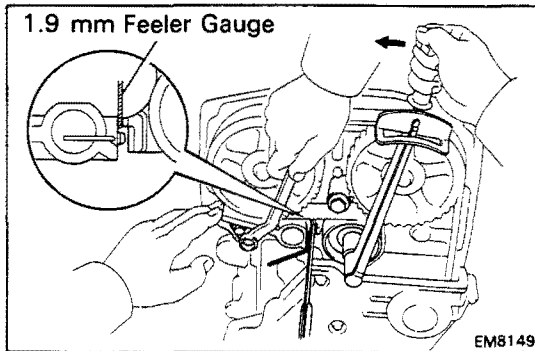

- (c) Insert a 1.90 mm (0.075 in.) feeler gauge between the tensioner body and No.1 idler pulley stopper.
- (d) Turn the No.1 idler pulley bolt counterclockwise to obtain the specified torque.

**Torque: 180 kg-cm (13 ft-lb, 18 N·m)**

- (e) While pushing the tensioner, alternately tighten the two bolts.

**Torque: 210 kg-cm (15 ft-lb, 21 N·m)**

- (f) Remove the 1.27 mm hexagon wrench from the tensioner.

- (g) Slowly turn the crankshaft pulley one revolution, and align its groove with the ATDC 60° mark of the No.1 timing belt cover.

**NOTICE: Always turn the crankshaft.**

- (h) Turn the No.1 idler pulley bolt counterclockwise to obtain the specified torque.

**Torque: 180 kg-cm (13 ft-lb, 18 N·m)**

**NOTICE: To apply the correct torque, apply the torque wrench along the axis through the bolts of the No.1 idler pulley and exhaust camshaft timing pulley.**

- (i) Using a feeler gauge, check the specified clearance between the tensioner body and No.1 idler pulley stopper.

**Clearance: 1.80 – 2.20 mm (0.071 – 0.087 in.)**

If the push rod clearance is not as specified, remove the tensioner and reinstall it.

#### 14. CHECK VALVE TIMING

- (a) Slowly turn the crankshaft pulley two revolutions from TDC to TDC.

**NOTICE: Always turn the crankshaft clockwise.**

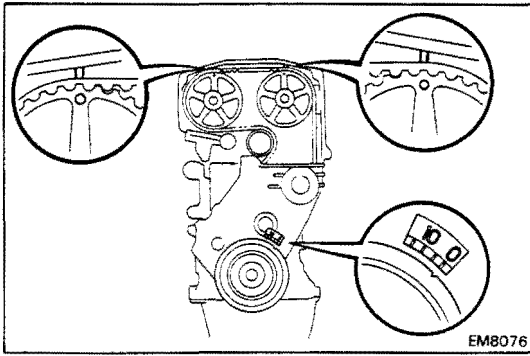

EM8076

- (b) Check that each pulley aligns with the timing marks as shown in the figure.

If the marks do not align, remove the timing belt and reinstall it.

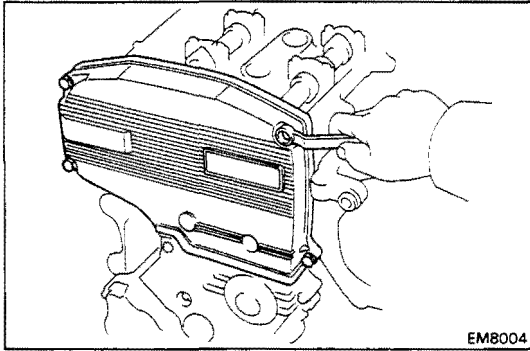

EM8004

#### 15. INSTALL NO.2 TIMING BELT COVER

- (a) Install the gasket to the timing belt cover.  
 (b) Install the belt cover with the five bolts.

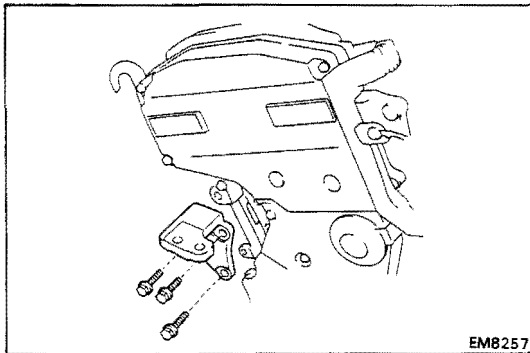

EM8257

#### 16. INSTALL ENGINE RH MOUNTING BRACKET

Install the bracket with the three bolts.

Torque: 530 kg-cm (38 ft-lb, 52 N·m)

#### 17. INSTALL SPARK PLUGS

Torque: 180 kg-cm (13 ft-lb, 18 N·m)

#### 18. INSTALL CYLINDER HEAD COVER

3S-GE (See step 7 on page EM-131)

3S-GTE (See step 7 on page EM-140)

#### 19. (3S-GTE)

##### INSTALL THROTTLE BODY

(See steps 2 to 7 on page FI-172 and 173)

#### 20. (3S-GTE)

##### INSTALL EGR VALVE AND PIPE

(See step 19 on page EM-143)

#### 21. (3S-GTE)

##### INSTALL EGR VACUUM MODULATOR

(See step 20 on page EM-143)

#### 22. (3S-GTE)

##### INSTALL INTERCOOLER

(See steps 11 to 13 on page TC-16)

#### 23. (3S-GE)

##### INSTALL AIR INTAKE CHAMBER

(See step 15 on page EM-132)

#### 24. INSTALL ALTERNATOR

3S-GE (See step 26 on page EM-136)

3S-GTE (See step 30 on page EM-146)

**ADJUSTMENT OF VALVE TIMING**

1. **REMOVE ALTERNATOR**  
3S-GE (See step 2 on page EM-101)  
3S-GTE (See step 3 on page EM-108)
2. **(3S-GE)**  
**REMOVE AIR INTAKE CHAMBER**  
(See step 13 on page EM-105)
3. **(3S-GTE)**  
**REMOVE INTERCOOLER**  
(See steps 4 to 6 on page TC-9)
4. **REMOVE SPARK PLUGS** 
5. **REMOVE NO.2 TIMING BELT COVER**  
(See step 10 on page EM-46)

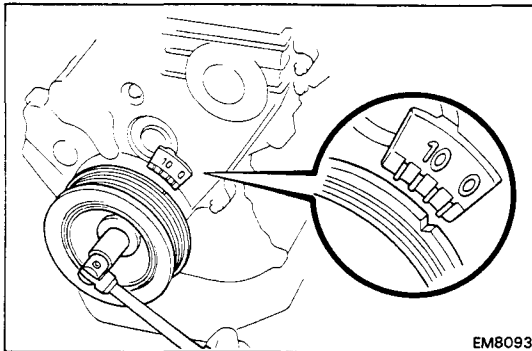
6. **CHECK CAMSHAFT TIMING PULLEY MARKS**

- (a) Turn the crankshaft pulley, and align its groove with timing mark "0" of the No.1 timing belt cover.

**NOTICE:** Always turn the crankshaft clockwise.

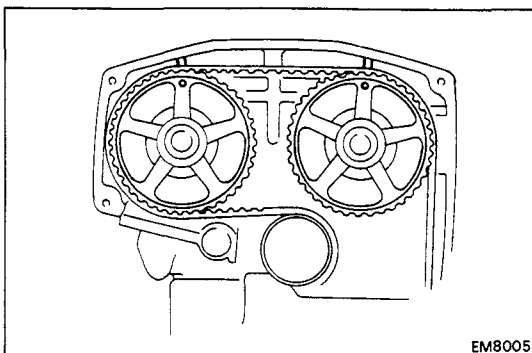

- (b) Check that the timing marks of the camshaft timing pulleys are aligned with the timing mark of the No.3 timing belt cover.

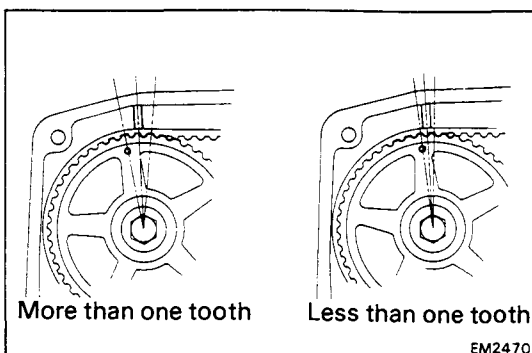

- If there is more than one timing pulley tooth between the timing marks, realign the timing marks in accordance with step 11.
- If the timing marks are aligned or the difference is less than one timing pulley tooth, proceed to step 12.

7. **(3S-GTE)**  
**REMOVE EGR VACUUM MODULATOR**  
(See step 13 on page EM-111)

8. (3S-GTE)  
REMOVE EGR VALVE AND PIPE  
(See step 14 on page EM-111)
9. (3S-GTE)  
REMOVE THROTTLE BODY  
(See steps 5 to 10 on pages FI-170 and 171)
10. REMOVE CYLINDER HEAD COVER  
3S-GE (See step 21 on page EM-106)  
3S-GTE (See step 26 on page EM-114)

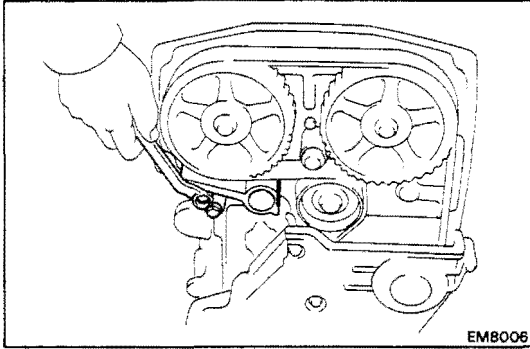

EM8006

11. ADJUST CAMSHAFT TIMING PULLEY TIMING MARKS

(a) Remove the two bolts and timing belt tensioner.

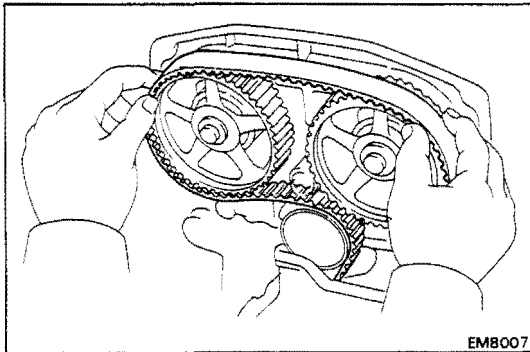

EM8007

(b) Remove the timing belt from the camshaft timing pulleys.

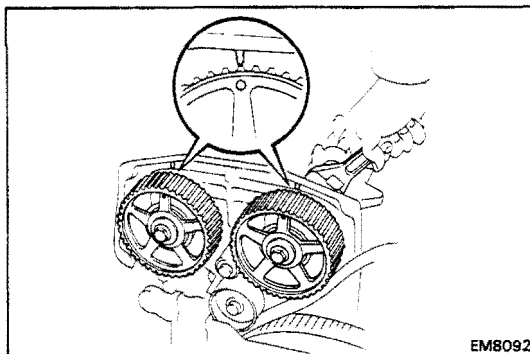

EM8092

(c) Rotate the camshaft with a wrench and align the alignment marks of the camshaft timing pulley and No.3 timing belt cover.

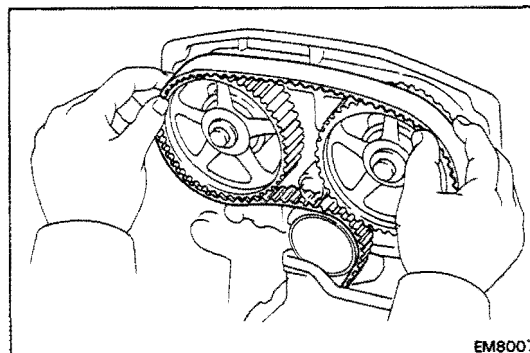

EM8007

(d) Reinstall the timing belt, insure that there is tension between the crankshaft timing pulley and intake camshaft timing pulley.

**NOTICE:** Install the timing belt when the engine is cold.

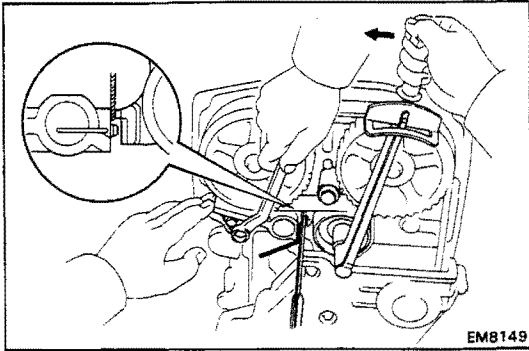

- (e) Install the timing belt tensioner with the two bolts.  
(See steps 12 and 13 on page EM-56)

**Torque: 210 kg-cm (15 ft-lb, 21 N·m)**

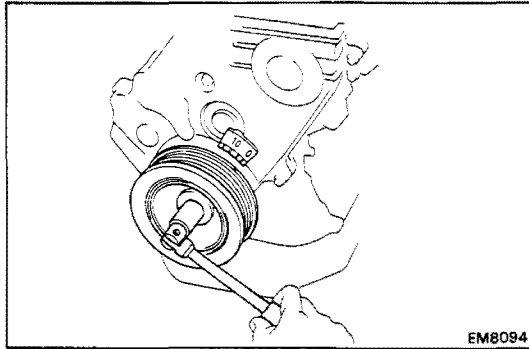

- (f) Turn the crankshaft pulley two revolutions from TDC to TDC.

**NOTICE: Always turn the crankshaft clockwise.**

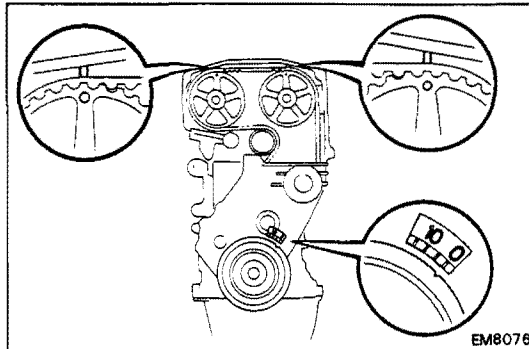

- (g) Check that each pulley aligns with the timing marks as shown in the figure
- (h) Check the push rod clearance of the timing belt tensioner. (See step is on page EM-58)

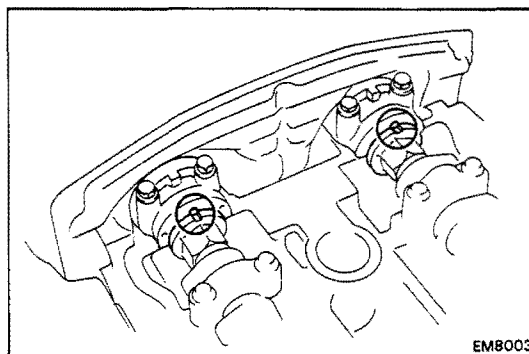

## 12. CHECK VALVE TIMING

- (a) Using a wrench, turn and align the groove of the camshaft with the drilled mark of the No.1 camshaft bearing cap.

**NOTICE: Always turn the crankshaft clockwise.**

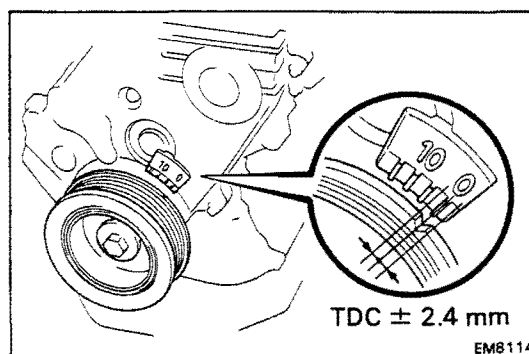

- (b) Next make a note of the crankshaft pulley angle on the No.1 timing belt cover.

**HINT:** Perform this check separately for the intake and exhaust sides.

If the crankshaft pulley movement is within  $\pm 2.4$  mm (0.094 in.) of TDC it is correct.

If it is greater than 2.4 mm (0.094 in.), go back to step 11.

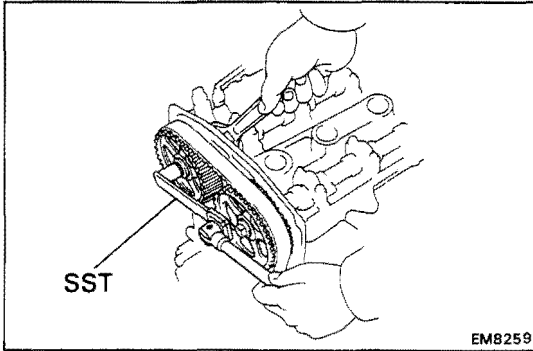

### 13. ADJUST VALVE TIMING

- (a) Hold the hexagonal wrench head portion of the camshaft with a wrench, and remove the two camshaft timing pulley bolts.

**HINT** (On vehicle for intake camshaft timing pulley): Use SST.

SST 09249-63010

**NOTICE:** Do not make use of the timing belt tension when loosening the pulley bolts.

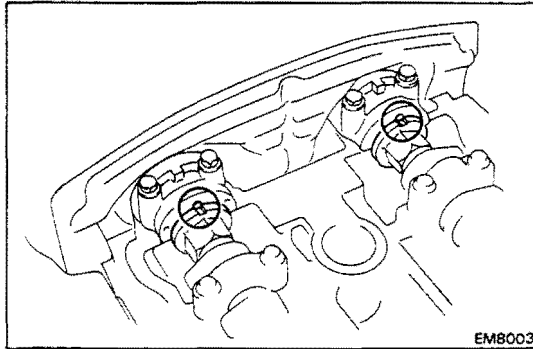

- (b) Check that the camshaft grooves are aligned with the drilled mark of the No.1 camshaft bearing cap.

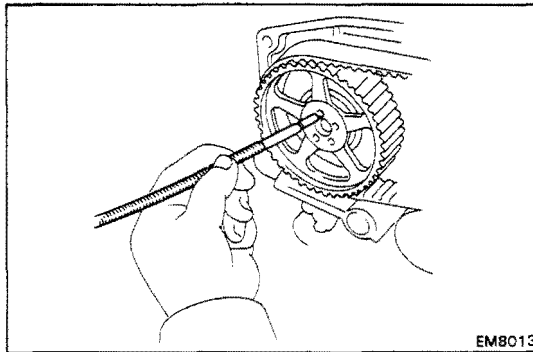

- (c) Using a magnetic finger, remove the knock pin from the pin hole of the camshaft timing pulley.

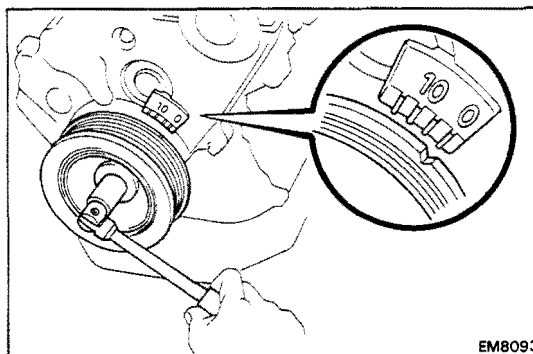

- (d) Turn the crankshaft pulley, and align its groove with timing mark "0" of the No.1 timing belt cover.

**NOTICE:** Always turn the crankshaft clockwise.

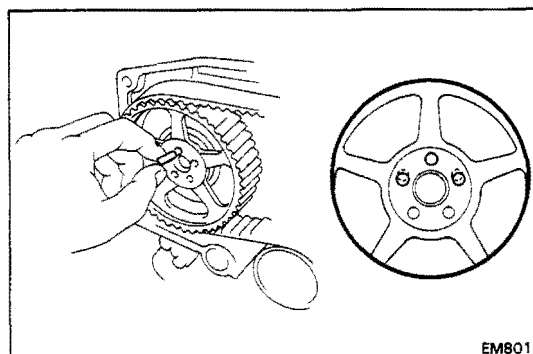

- (e) Select one overlapped hole of the camshaft and timing pulley, and insert the match pin into it.

**HINT:**

- If there is not an overlapped hole, rotate the crankshaft a little and insert the pin into the nearly overlapped hole.
- By changing the pin hole to the next one, the crankshaft pulley angle can be adjusted by approx. 2°.
- By changing the pin hole to the next two, the crankshaft pulley angle can be adjusted by approx. 5°.

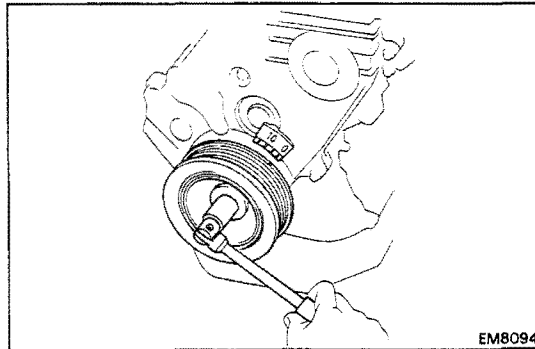
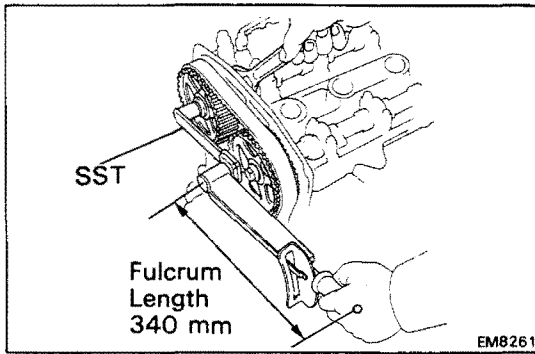

- (f) Hold the hexagonal wrench head portion of the camshaft with a wrench, and install the pulley bolt.

**Torque:** 600 kg-cm (43 ft-lb, 59 N·m)  
420 kg-cm (30 ft-lb, 41 N·m) for SST

**HINT** (On vehicle for intake camshaft timing pulley):

- Use SST.

SST 09249-63010

- Use a torque wrench with a fulcrum length of 340 mm (13.39 in.).

**NOTICE:** Do not make use of the timing belt tension when tightening the bolt.

- (g) Turn the crankshaft clockwise two revolutions from TDC to TDC.

- (h) Recheck the valve timing.  
(See step 12 on page EM-61)

**14. REINSTALL NO.2 TIMING BELT COVER**  
(See step 15 page EM-57)

**15. REINSTALL SPARK PLUGS**

**Torque:** 180 kg-cm (13 ft-lb, 18 N·m)

**16. REINSTALL CYLINDER HEAD COVER**  
**3S-GE** (See step 7 on page EM-131)  
**3S-GTE** (See step 7 on page EM-140)

**17. (3S-GTE)**  
**REINSTALL THROTTLE BODY**  
(See steps 2 to 7 on pages FI-172 and 173)

**18. (3S-GTE)**  
**REINSTALL EGR VALVE AND PIPE**  
(See step 19 on page EM-143)

**19. (3S-GTE)**  
**REINSTALL EGR VACUUM MODULATOR**  
(See step 20 on page EM-143)

**20. (3S-GTE)**  
**REINSTALL INTERCOOLER**  
(See steps 11 to 13 on page TC-16)

**21. (3S-GE)**  
**REINSTALL AIR INTAKE CHAMBER**  
(See step 15 on page EM-132)

**22. REINSTALL ALTERNATOR**



# CYLINDER HEAD (5S-FE) COMPONENTS

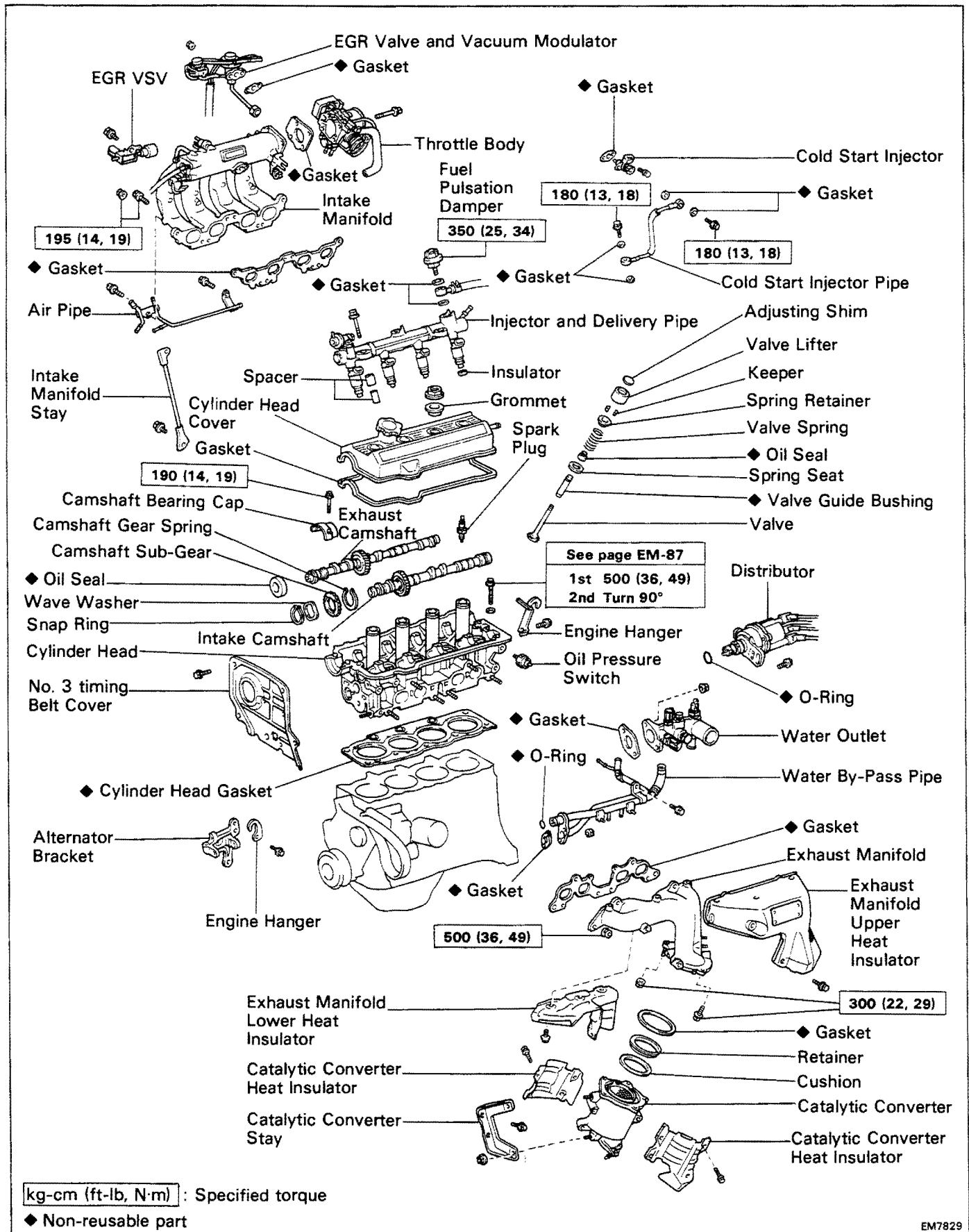

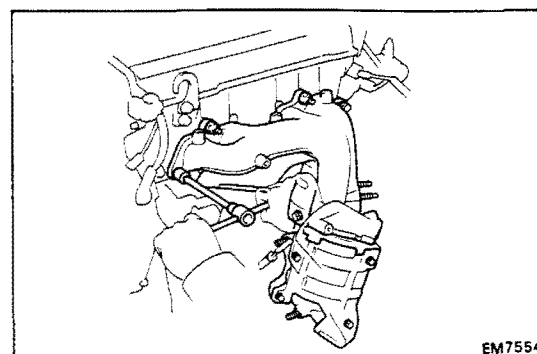
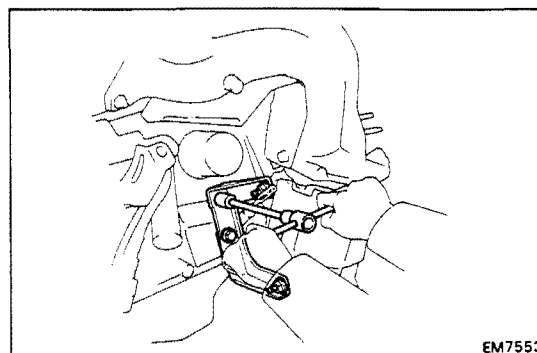
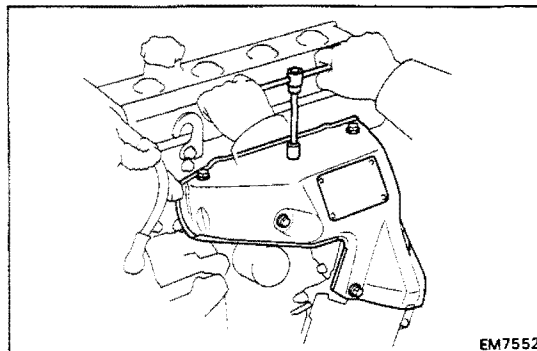
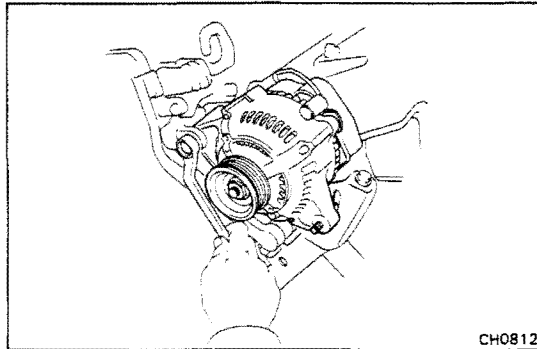
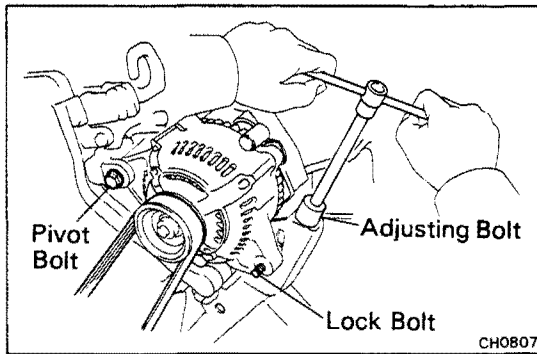

## REMOVAL OF CYLINDER HEAD

(See page EM-64)

### 1. DRAIN ENGINE COOLANT

### 2. REMOVE ALTERNATOR

- (a) Loosen the pivot bolt and adjusting lock bolt.
- (b) Loosen the adjusting bolt, and remove the drive belt.
- (c) Disconnect the alternator connector.
- (d) Remove the nut, and disconnect the alternator wire.
- (e) Remove the pivot bolt, adjusting lock bolt and alternator.

### 2. REMOVE DISTRIBUTOR

### 3. REMOVE EXHAUST MANIFOLD AND CATALYTIC CONVERTER ASSEMBLY

- (a) Disconnect the oxygen sensor connector.
- (b) Remove the six bolts and manifold upper heat insulator.
- (c) Remove the two bolts, two nuts and catalytic converter stay.
- (d) Remove the six nuts, the exhaust manifold and catalytic converter assembly.

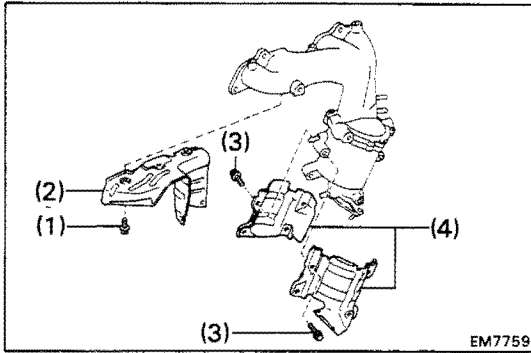

#### 4. SEPARATE EXHAUST MANIFOLD AND CATALYTIC CONVERTER

Remove the following parts:

- (1) Five bolts
- (2) Manifold lower heat insulator
- (3) Eight bolts
- (4) Two catalytic converter heat insulators

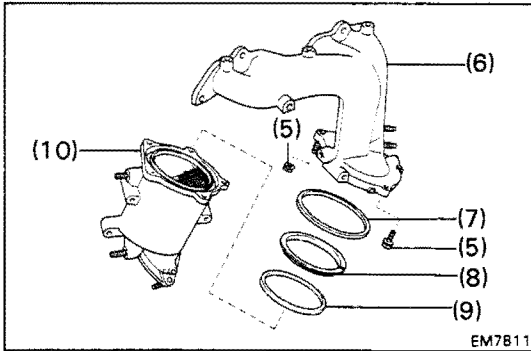

- (5) Three bolts and two nuts
- (6) Exhaust manifold
- (7) Gasket
- (8) Retainer
- (9) Cushion
- (10) Catalytic converter

#### 5. REMOVE WATER OUTLET

(a) Disconnect the following connectors:

- Water temperature sender gauge connector
- Water temperature sensor connector
- Cold start injector time switch connector

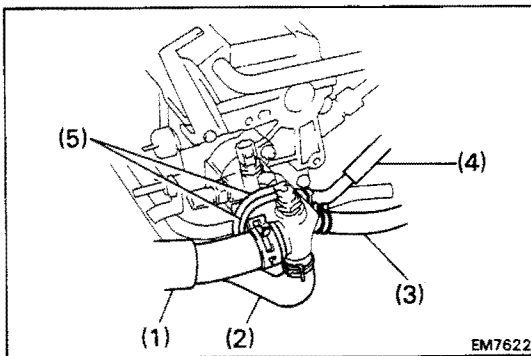

(b) Disconnect the following hoses:

- (1) Upper radiator hose
- (2) Water by-pass pipe hose
- (3) Heater water hose
- (4) ISC water by-pass hose
- (5) Two EVAP BVSV vacuum hoses

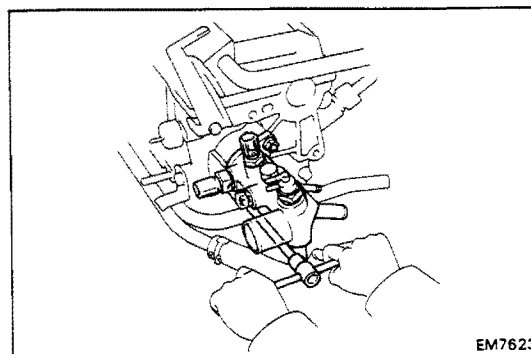

(c) Remove the two bolts, water outlet and gasket.

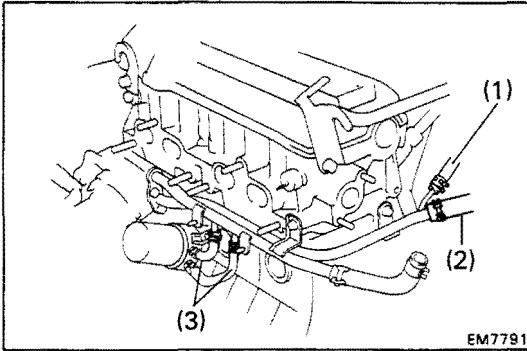
**6. REMOVE WATER BY-PASS PIPE**

- (a) (w/ Oil Cooler)  
Remove the oil cooler heat protector  
(See step 5 on page LU-16)
- (b) Disconnect the following hoses:
  - (1) ISC water by-pass hose
  - (2) Heater water hose
  - (3) (w/ Oil Cooler)  
Two oil cooler water by-pass hoses
- (c) Remove the two bolts, two nuts, water by-pass pipe and gasket.
- (d) Remove the O-ring from the water by-pass hose.

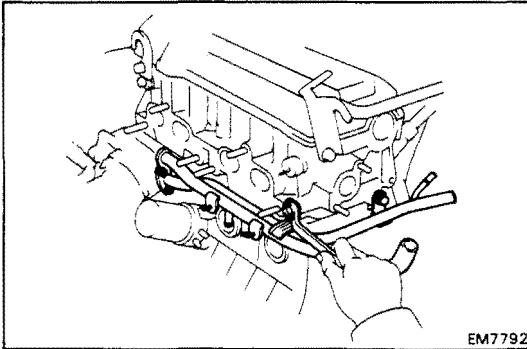
**7. REMOVE THROTTLE BODY**

(See steps 6 to 9 on pages FI-159 and 160)

**8. REMOVE COLD START INJECTOR PIPE**

(See step 3 on page FI-118)

**9. REMOVE COLD START INJECTOR**

(See steps 2 and 4 on pages FI-118 and 119)

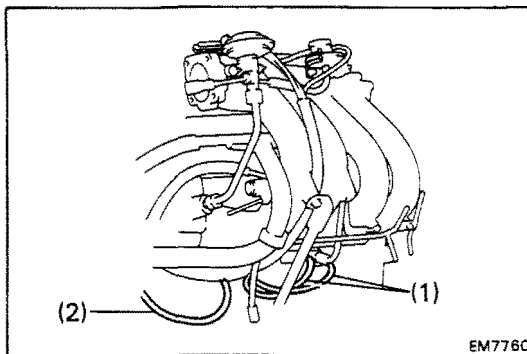
**10. REMOVE EGR VALVE AND VACUUM MODULATOR**

- (a) Remove the following hoses:
  - (1) Two vacuum hoses from EGR VSV
  - (2) Vacuum hose from charcoal canister
- (b) Loosen the union nut of the EGR pipe, and remove two bolts, the EGR valve, vacuum modulator, vacuum hoses assembly and gasket.

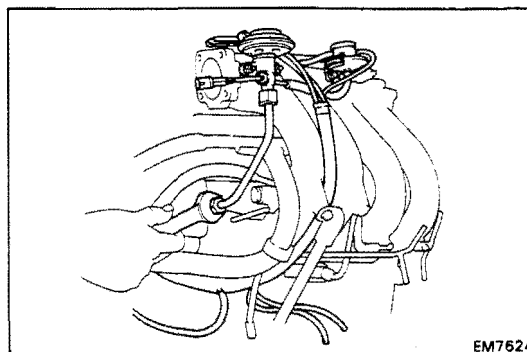

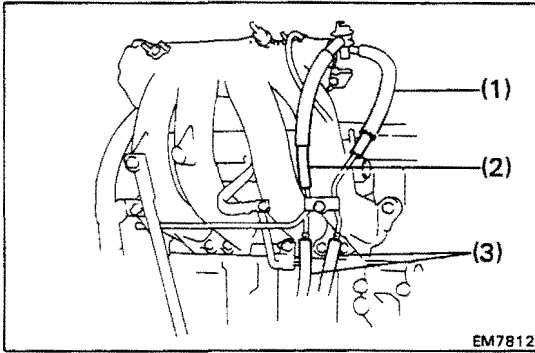
**11. REMOVE AIR TUBE**

- (a) Disconnect the following hoses:
  - (1) Air hose from intake manifold
  - (2) (w/ A/C)  
Air hose from A/C ASV
  - (3) Two air hoses from PS pump
- (b) Disconnect the engine wire clamp from the wire bracket.
- (c) Remove the two bolts, wire bracket and air tube.

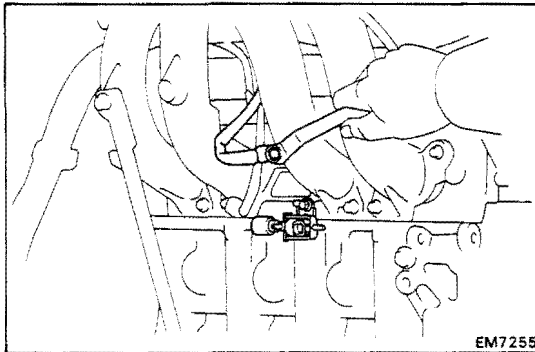
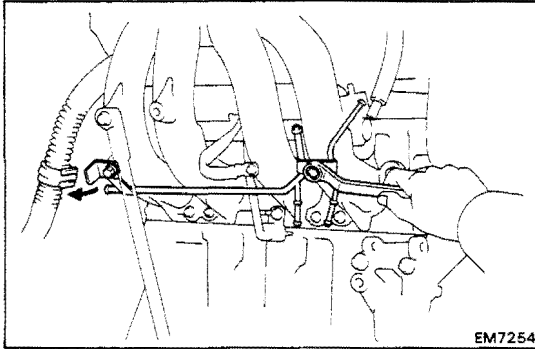
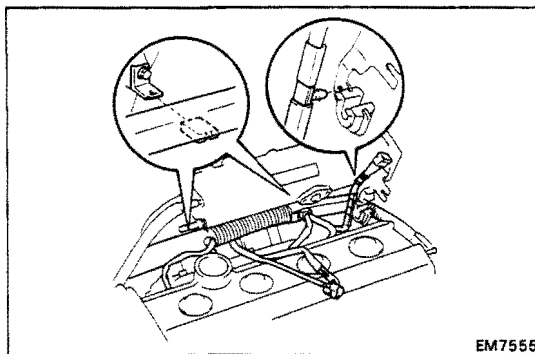
**12. DISCONNECT ENGINE WIRE GROUND STRAP FROM INTAKE MANIFOLD****13. REMOVE EGR VSV****14. REMOVE INTAKE MANIFOLD**

- (a) Disconnect the two wire clamps from the wire brackets.
- (b) Disconnect the wire clip from the accelerator bracket.
- (c) Remove the two bolts and manifold stay.

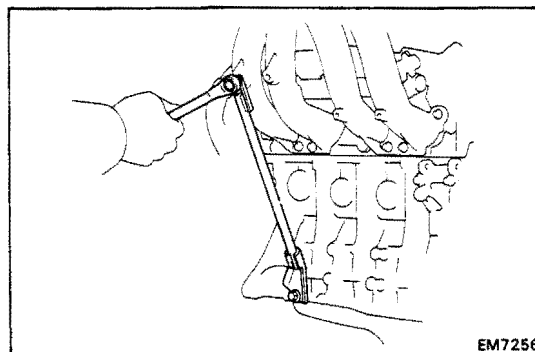

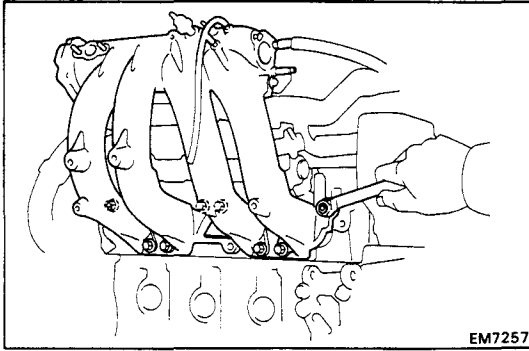

- (d) Disconnect the vacuum sensing hose.
- (e) Remove the six bolts, two nuts, intake manifold and gasket.

**15. REMOVE DELIVERY PIPE AND INJECTORS**

(See steps 6, 8 and 9 on pages FI-135 and 136)

**16. REMOVE CAMSHAFT TIMING PULLEY**

(See steps 3 to 8 on pages EM-33 to 35)

**17. REMOVE NO.1 IDLER PULLEY AND TENSION SPRING**

(See step 13 on page EM-37)

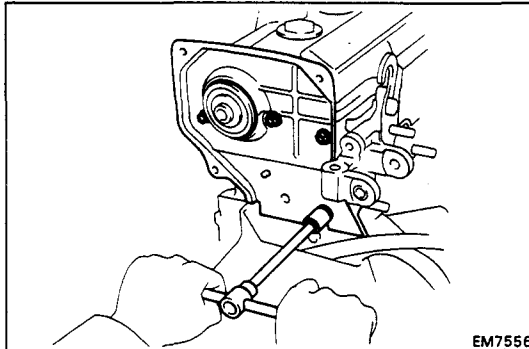

**18. REMOVE NO.3 TIMING BELT COVER**

Remove the four bolts and timing belt cover.

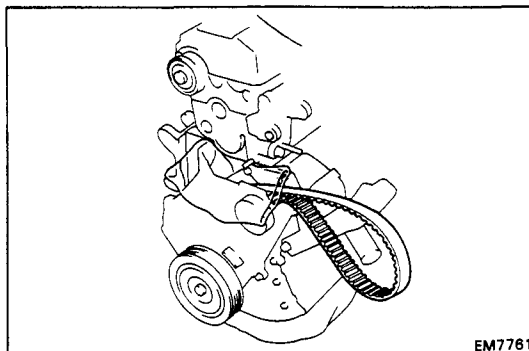

**NOTICE:**

- Support the timing belt, so that the meshing of the crankshaft timing pulley and timing belt does not shift.
- Be careful not to drop anything inside the timing belt cover.
- Do not allow the belt to come into contact with oil, water or dust.

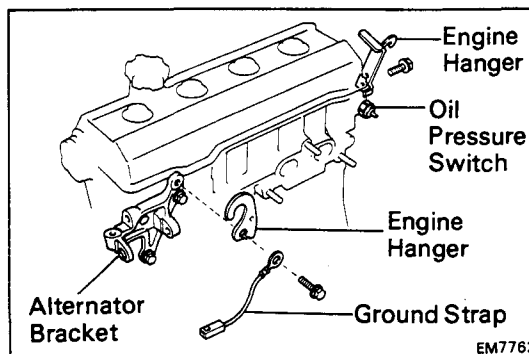

**19. REMOVE ENGINE HANGERS**

Remove the bolt and engine hanger. Remove the two engine hangers. Remove the ground strap.

**20. REMOVE ALTERNATOR BRACKET**

Remove the three bolts and alternator bracket.

**21. REMOVE OIL PRESSURE SWITCH**

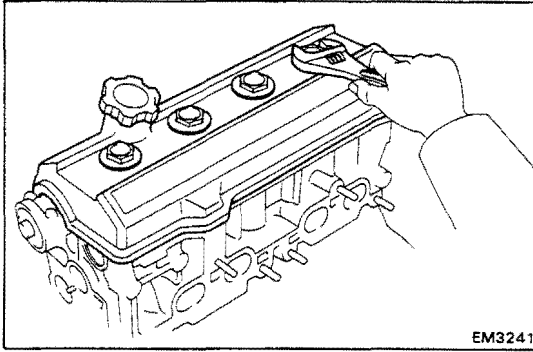

## 22. REMOVE CYLINDER HEAD COVER

Remove the four nuts, grommets, head cover and gasket.

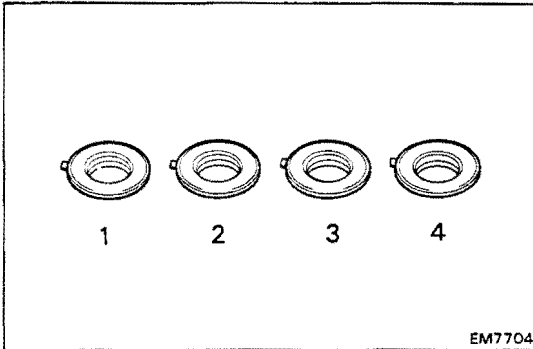

**HINT:** Arrange the grommets in correct order, so that they can be reinstalled into their original positions. This minimizes any possibility of oil leakage due to reuse of grommets.

## 23. REMOVE CAMSHAFTS

**NOTICE:** Since the thrust clearance of the camshaft is small, the camshaft must be kept level while it is being removed. If the camshaft is not kept level, the portion of the cylinder head receiving the shaft thrust may crack or be damaged, causing the camshaft to seize or break. To avoid this, the following steps should be carried out.

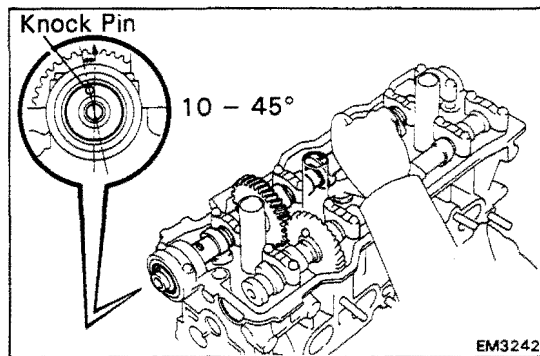

### A. Remove exhaust camshaft

- (a) Set the knock pin of the intake camshaft at 10 – 45° BTDC of camshaft angle.

**HINT:** The above angle allows No.2 and No.4 cylinder cam lobes of the exhaust camshaft to push their valve lifters evenly.

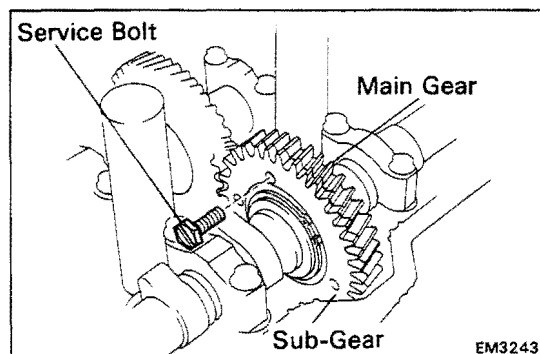

- (b) Secure the exhaust camshaft sub-gear to drive gear with a service bolt.

Recommended service bolt:

Thread diameter	6 mm
Thread pitch	1.0 mm
Bolt length	16 – 20 mm (0.63 – 0.79 in.)

**HINT:** When removing the camshaft, make certain that the torsional spring force of the sub-gear has been eliminated by the above operation.

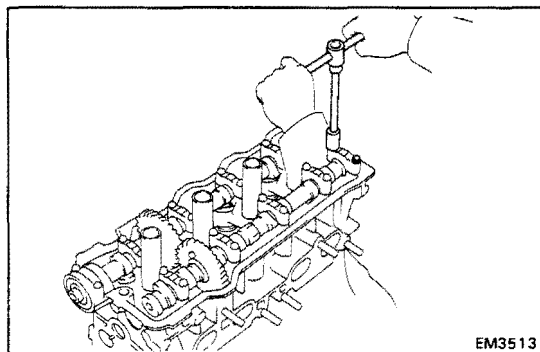

(c) Remove the two bolts and rear bearing cap.

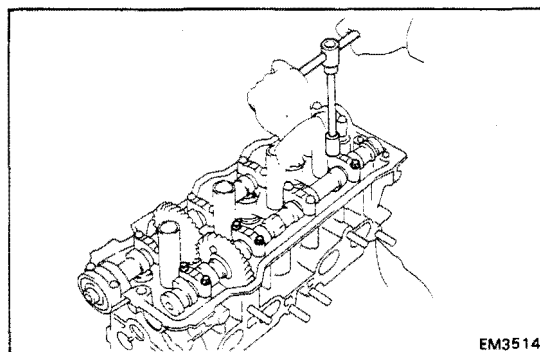

(d) Uniformly loosen and remove the six bolts on the No.1, No.2 and No.4 bearing cap in several passes in the sequence shown.

**NOTICE:** Do not remove the No.3 bearing cap bolts at this stage.

(e) Remove the No.1, No.2 and No.4 bearing caps.

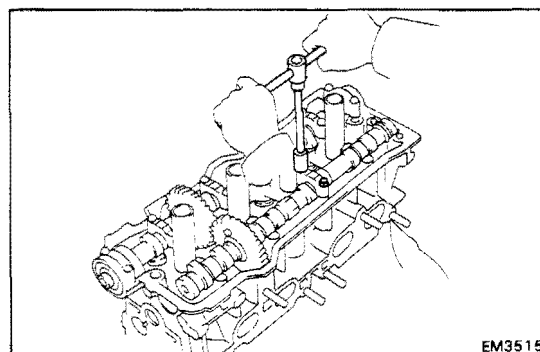

(f) Alternately loosen and remove the two bolts on the No.3 bearing cap.

**HINT:**

- As two No.3 bearing cap bolts are loosened, check that the camshaft being lifted out straight and level.
- If the camshaft is not being lifted out straight and level, retighten the two No.3 bearing cap bolts. Then reverse the order of above steps from (f) to (a) and reset the knock pin of the intake camshaft at 10 – 45° BTDC, and repeat steps from (b) to (f) once again.

**NOTICE:** Do not pry on or attempt to force the camshaft with a tool or other object.

(g) Remove the No.3 bearing cap and exhaust camshaft.

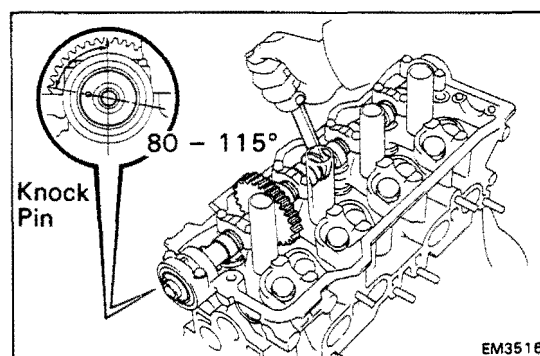

**B. Remove intake camshaft**

(a) Set the knock pin of the intake camshaft at 80 – 115° BTDC of camshaft angle.

**HINT:** The above angle allows the No.1 and No.3 cylinder cam lobes of intake camshaft to push their valve lifters evenly.

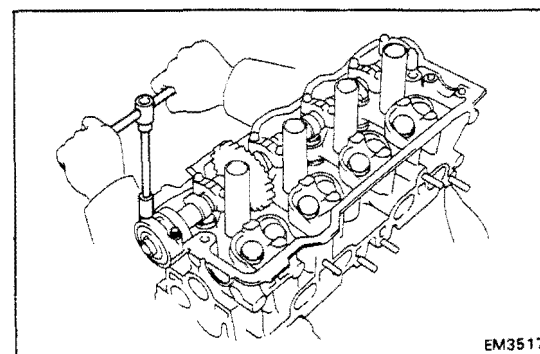

(b) Remove the two bolts, front bearing cap and oil seal.



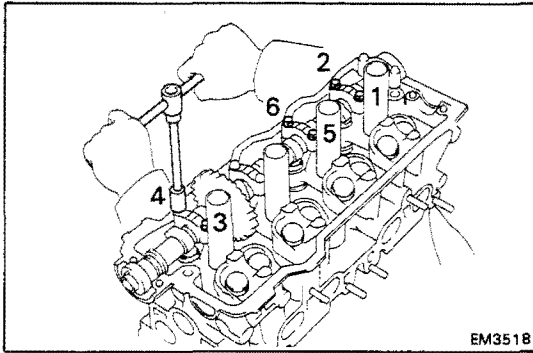

- (c) Uniformly loosen and remove the bolts on the No.1, No.3 and No.4 bearing cap in several passes in the sequence shown.

**NOTICE:** Do not remove the No.2 bearing cap bolts at this stage.

- (d) Remove the No.1, No.3 and No.4 bearing caps.

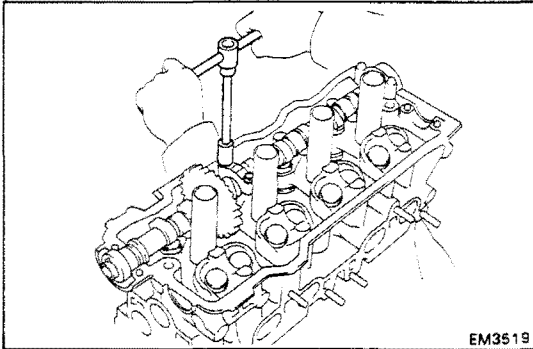

- (e) Alternately loosen and remove the two bolts on the No.2 bearing cap.

**HINT:**

- As two No.2 bearing cap bolts are loosened, check that the camshaft is being lifted out straight and level, after breaking adhesion on the front bearing cap.
- If the camshaft is not being lifted out straight and level, retighten the two No.2 bearing cap bolts. Reverse the order of above steps from (e) to (a) and reset the knock pin of the intake camshaft at 80 – 115° BTDC, and repeat steps from (b) to (e) once again.

**NOTICE:** Do not pry on or attempt to force the camshaft with a tool or other object.

- (f) Remove the No.2 bearing cap and camshaft.

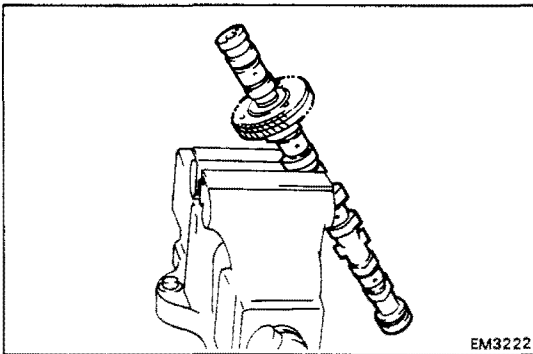

#### 24. DISASSEMBLE EXHAUST CAMSHAFT

- (a) Mount the hexagonal wrench head portion of the camshaft in a vise.

**NOTICE:** Be careful not to damage the camshaft.

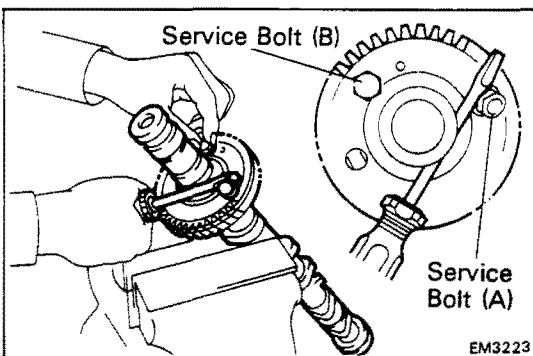

- (b) Insert a service bolt (A) into the service hole of the camshaft sub-gear.

- (c) Using a screwdriver, turn the sub-gear clockwise, and remove the service bolt (B).

**NOTICE:** Be careful not to damage the camshaft.

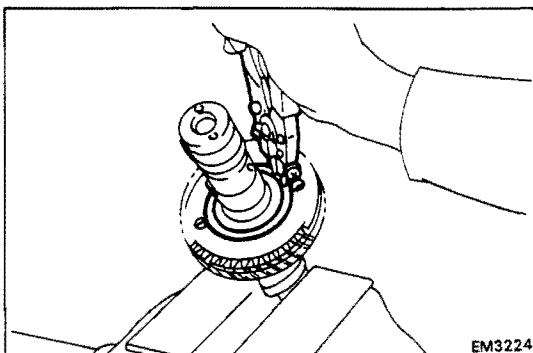

- (d) Using snap ring pliers, remove the snap ring.

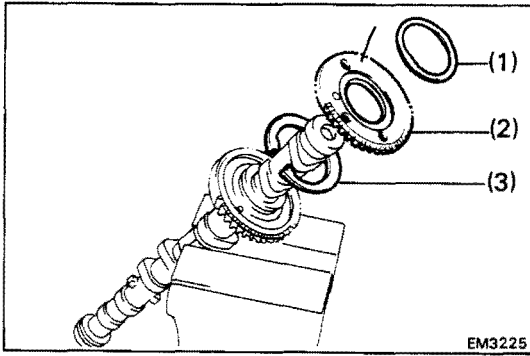

(e) Remove the following parts:

- (1) Wave washer
- (2) Camshaft sub-gear
- (3) Camshaft gear spring

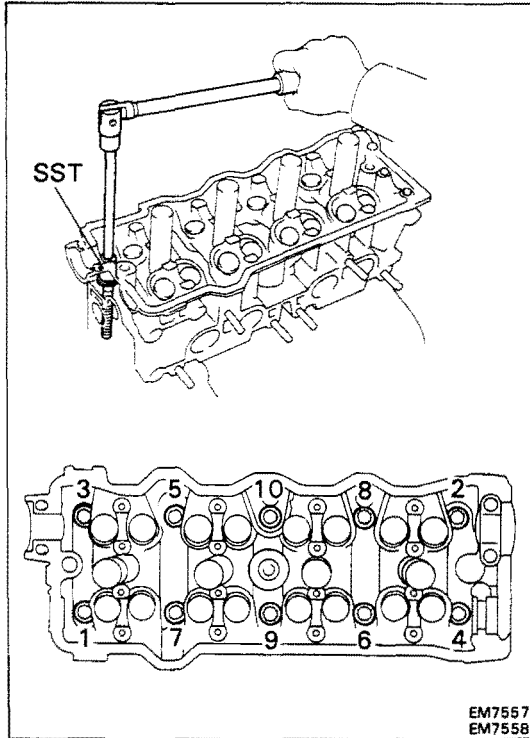

## 25. REMOVE CYLINDER HEAD

(a) Using SST, uniformly loosen and remove the ten cylinder head bolts in several passes in the sequence shown.

SST 09011-38121

**NOTICE:** Cylinder head warpage or cracking could result from removing bolts in the incorrect order.

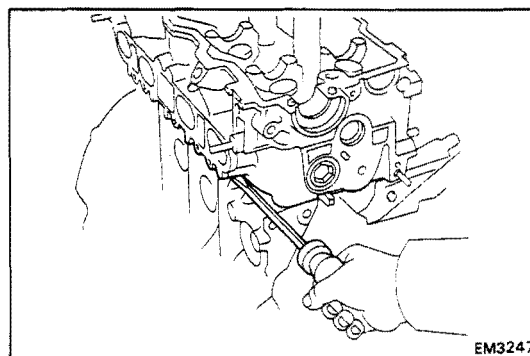

(b) Lift the cylinder head from the dowels on the cylinder block, and place the cylinder head on wooden blocks on a bench.

**HINT:** If the cylinder head is difficult to lift off, pry between the cylinder head and cylinder block with a screwdriver.

**NOTICE:** Be careful not to damage the contact surfaces of the cylinder head and cylinder block.

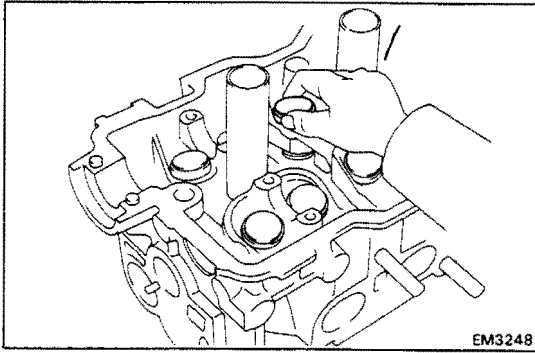

## DISASSEMBLY OF CYLINDER HEAD

(See page EM-64)

### 1. REMOVE VALVE LIFTERS AND SHIMS

**HINT:** Arrange the valve lifters and shims in correct order.

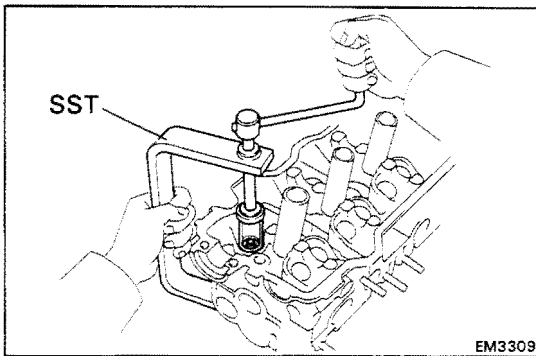
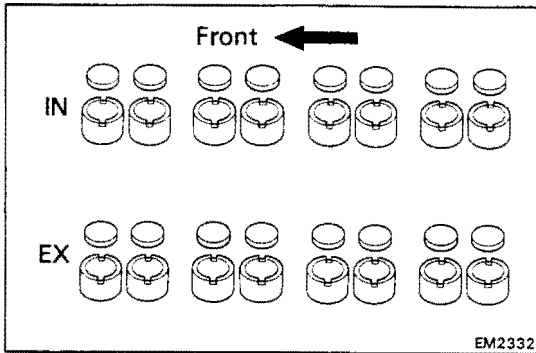

### 2. REMOVE VALVES

(a) Using SST, compress the valve spring and remove the two keepers.

SST 09202-70010

(b) Remove the spring retainer, valve spring, valve and spring seat.

**HINT:** Arrange the valves, valve springs, spring seats and spring retainers in correct order.

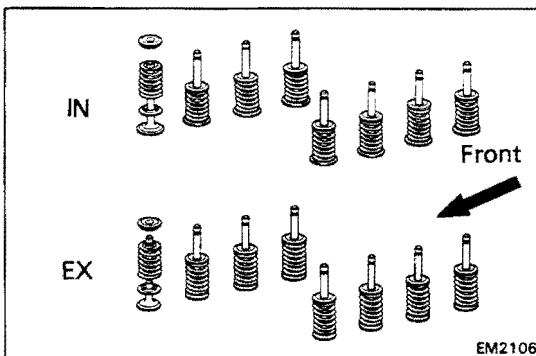

(c) Using needle-nose pliers, remove the oil seal.

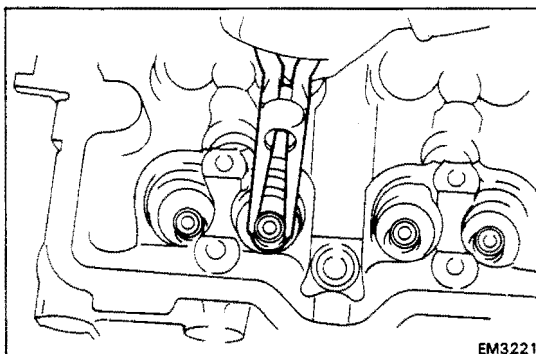

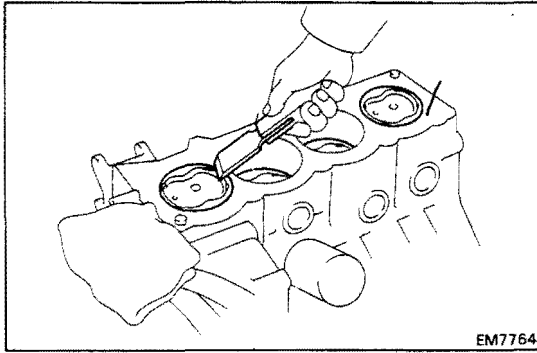

## INSPECTION, CLEANING AND REPAIR OF CYLINDER HEAD COMPONENTS

### 1. CLEAN TOP SURFACES OF PISTONS AND CYLINDER BLOCK

(a) Turn the crankshaft, and bring each piston to top dead center (TDC). Using a gasket scraper, remove all the carbon from the piston top surface.

(b) Using a gasket scraper, remove all the gasket material from the top surface of the cylinder block.

(c) Using compressed air, blow carbon and oil from the bolt holes.

**CAUTION:** Protect your eyes when using high-compressed air.

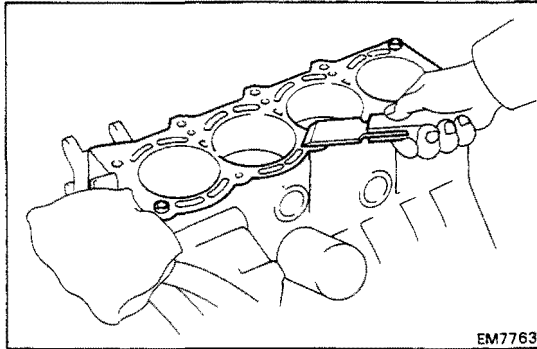

### 2. REMOVE GASKET MATERIAL

#### A. Remove gasket material

Using a gasket scraper, remove all the gasket material from the cylinder block surface.

**NOTICE:** Be careful not to scratch the cylinder block contact surface.

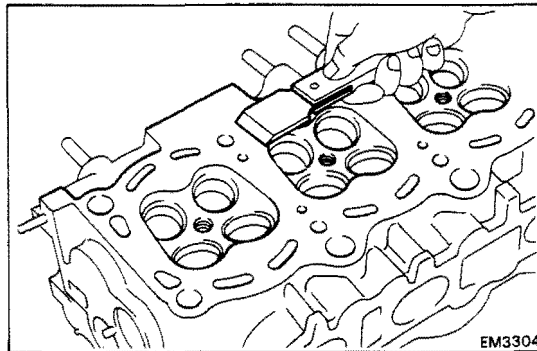

#### B. Clean combustion chambers

Using a wire brush, remove all the carbon from the combustion chambers.

**NOTICE:** Be careful not to scratch the cylinder block contact surface.

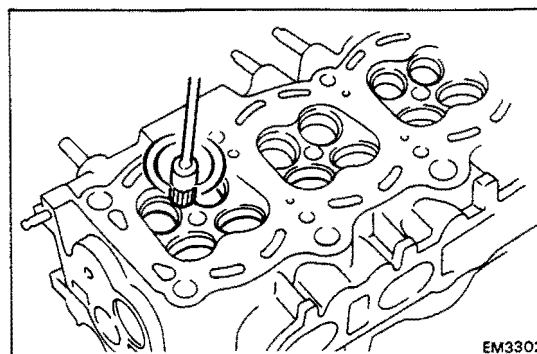

#### C. Clean valve guide bushings

Using a valve guide bushing brush and solvent, clean all the guide bushings.

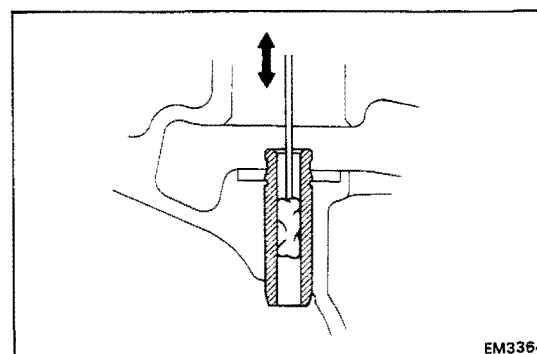

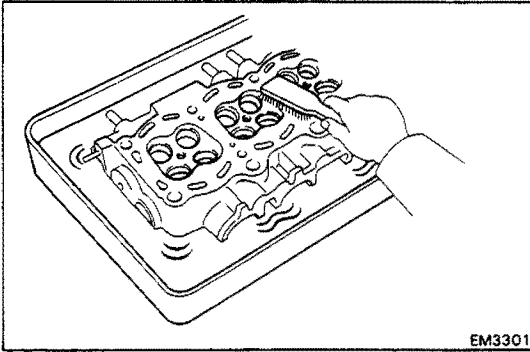

EM3301

#### D. Clean cylinder head

Using a soft brush and solvent, thoroughly clean the cylinder head.

/

### 3. INSPECT CYLINDER HEAD

#### A. Inspect for flatness

Using precision straight edge and feeler gauge, measure the surfaces contacting the cylinder block manifolds for warpage.

##### Maximum warpage:

Cylinder block side 0.05 mm (0.0020 in.)

Manifold side 0.08 mm (0.0031 in.)

If warpage is greater than maximum, replace the cylinder head.

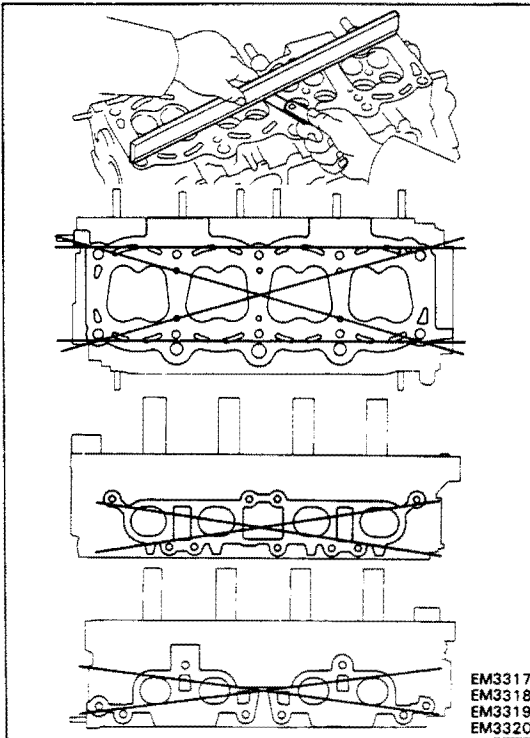
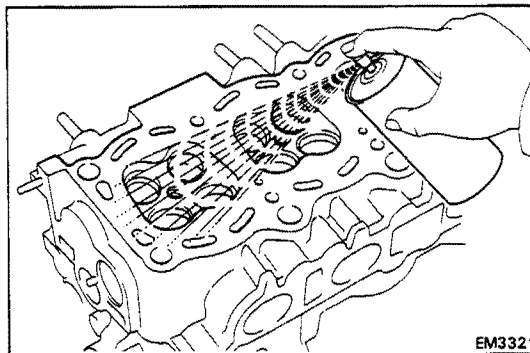
EM3317  
EM3318  
EM3319  
EM3320

EM3321

#### B. Inspect for cracks

Using a dye penetrant, check the combustion chamber, intake ports, exhaust ports and cylinder block surface for cracks.

If cracked, replace the cylinder head.

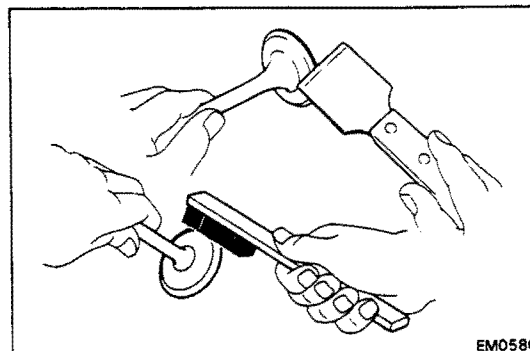

EM0580

### 4. CLEAN VALVES

(a) Using a gasket scraper, chip off any carbon from the valve head.

(b) Using a wire brush, thoroughly clean the valve.

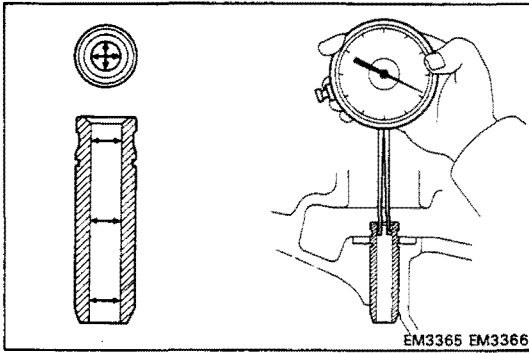

## 5. INSPECT VALVE STEMS AND GUIDE BUSHINGS

- (a) Using a caliper gauge, measure the inside diameter of the guide bushing.

**Bushing inside diameter:**

6.010 – 6.030 mm (0.2366 – 0.2374 in.)

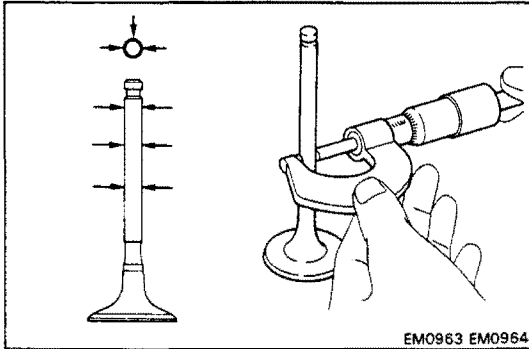

- (b) Using a micrometer, measure the diameter of the valve stem.

**Valve stem diameter:**

**Intake** 5.970 – 5.985 mm  
(0.2350 – 0.2356 in.)

**Exhaust** 5.965 – 5.980 mm  
(0.2348 – 0.2354 in.)

- (c) Subtract the valve stem diameter measurement from the guide bushing inside diameter measurement.

**Standard oil clearance:**

**Intake** 0.025 – 0.060 mm  
(0.0010 – 0.0024 in.)

**Exhaust** 0.030 – 0.065 mm  
(0.0012 – 0.0026 in.)

**Maximum oil clearance:**

**Intake** 0.08 mm (0.0031 in.)

**Exhaust** 0.10 mm (0.0039 in.)

If the clearance is greater than maximum, replace the valve and guide bushing.

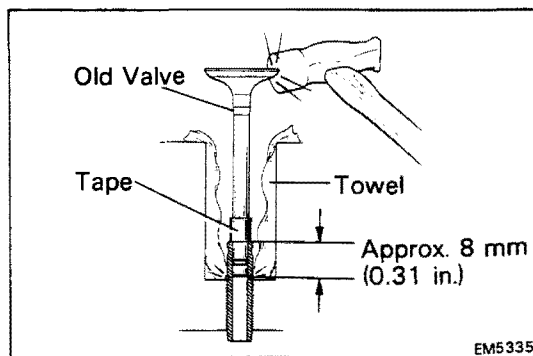

## 6. IF NECESSARY, REPLACE VALVE GUIDE BUSHINGS

- (a) (w/ Snap Ring)

Insert an old valve wrapped with tape into the valve guide bushing, and break off the valve guide bushing by hitting it with a hammer. Remove the snap ring.

**HINT:** Wrap the tape approx. 8 mm (0.31 in.) from the valve stem end.

**NOTICE:** Be careful not damage to the valve lifter hole.

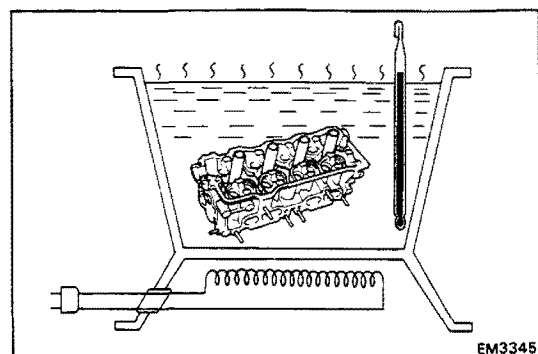

- (b) Gradually heat the cylinder head to 80 – 100°C (176 – 212°F).

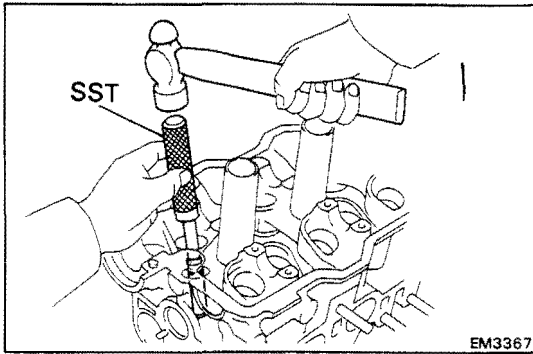

- (c) Using SST and a hammer, tap out the guide bushing.  
SST 09201-70010

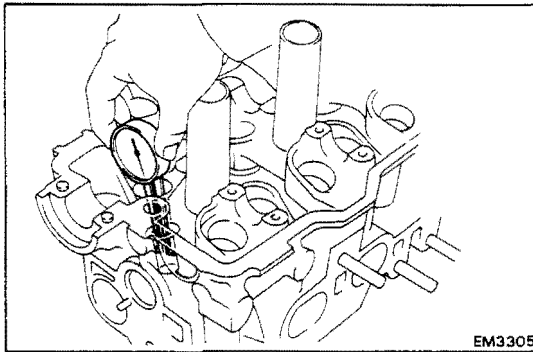

- (d) Using a caliper gauge, measure the bushing bore diameter of the cylinder head.

Both intake and exhaust

Bushing bore diameter mm (in.)	Bushing size
11.000 – 11.027 (0.4331 – 0.4342)	Use STD
11.050 – 11.077 (0.4350 – 0.4361)	Use O/S 0.05

- (e) Select a new guide bushing (STD size or O/S 0.05).  
If the bushing bore diameter of the cylinder head is greater than 11.027 mm (0.4341 in.), machine the bushing bore to the following dimension:

**11.050 – 11.077 mm (0.4350 – 0.4361 in.)**

- If the bushing bore diameter of the cylinder head is greater than 11.077 mm (0.4361 in.), replace the cylinder head.

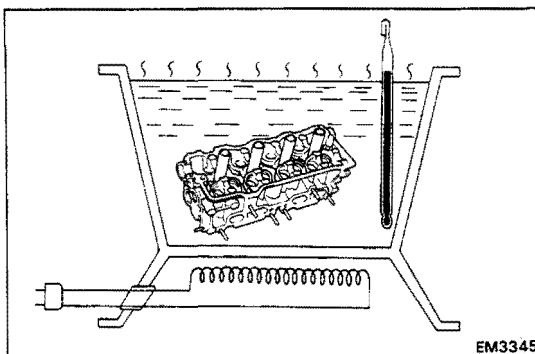

- (f) Gradually heat the cylinder head to 80 – 100°C (176 – 212°F).

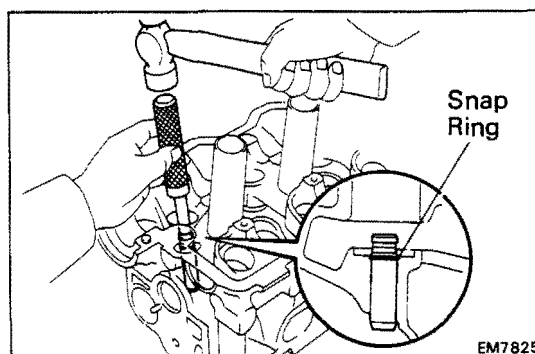

- (g) Using SST and a hammer, tap in a new guide bushing until the snap ring makes contact with the cylinder head.

SST 09201-70010

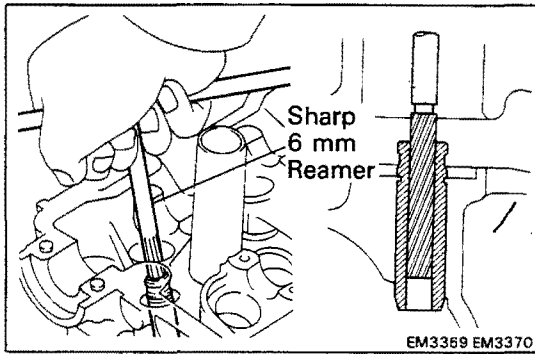

- (h) Using a sharp 6 mm reamer, ream the guide bushing to obtain the standard specified clearance (See page EM-77) between the guide bushing and valve stem.

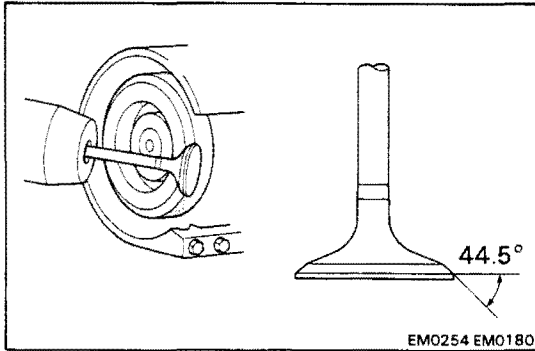

## 7. INSPECT AND GRIND VALVES

- (a) Grind the valve enough to remove pits and carbon.  
 (b) Check that the valve is ground to the correct valve face angle.

**Valve face angle: 44.5°**

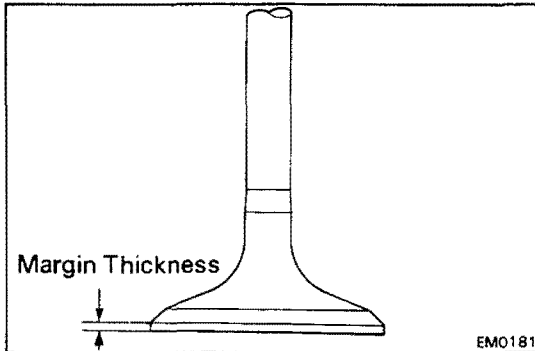

- (c) Check the valve head margin thickness.

**Standard margin thickness: 0.8 – 1.2 mm  
 (0.031 – 0.047 in.)**

**Minimum margin thickness: 0.5 mm (0.020 in.)**

If the margin thickness is less than minimum, replace the valve.

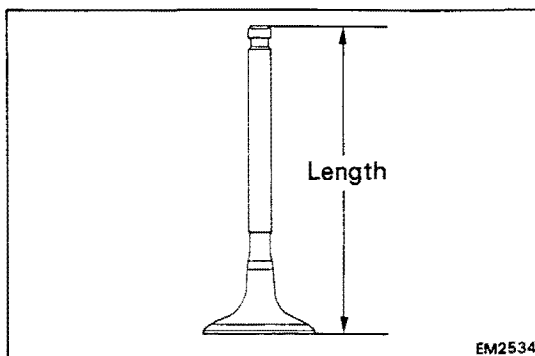

- (d) Check the valve overall length.

**Standard overall length:**

**Intake 100.60 mm (3.9606 in.)**

**Exhaust 100.45 mm (3.9547 in.)**

**Minimum overall length:**

**Intake 100.1 mm (3.941 in.)**

**Exhaust 100.0 mm (3.937 in.)**

If the overall length is less than minimum, replace the valve.

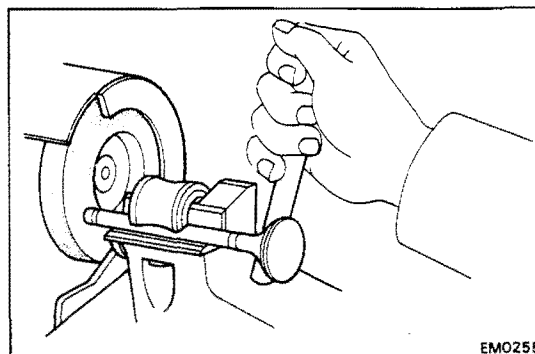

- (e) Check the surface of the valve stem tip for wear.

If the valve stem tip is worn, resurface the tip with a grinder or replace the valve.

**NOTICE: Do not grind off more than the minimum.**



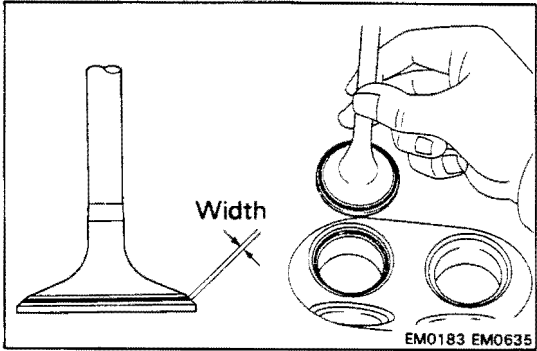
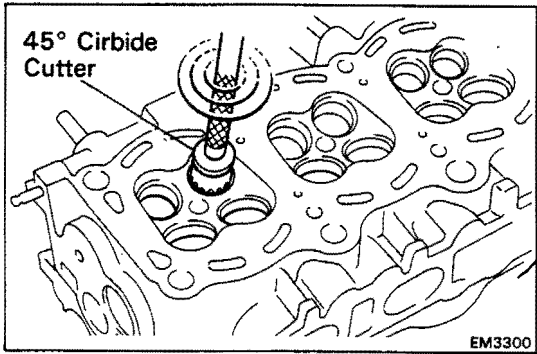

## 8. INSPECT AND CLEAN VALVE SEATS

- (a) Using a 45° carbide cutter, resurface the valve seats. Remove only enough metal to clean the seats.
- (b) Check the valve seating position. Apply a thin coat of prussian blue (or white lead) to the valve face. Lightly press the valve against the seat. Do not rotate the valve.
- (c) Check the valve face and seat for the following:
  - If blue appears 360° around the face, the valve is concentric. If not, replace the valve.
  - If blue appears 360° around the valve seat, the guide and face are concentric. If not, resurface the seat.
  - Check that the seat contact is in the middle of the valve face with the following width:  
1.0 – 1.4 mm (0.039 – 0.055 in.)

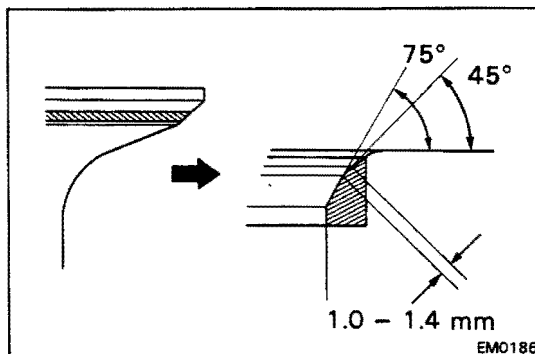
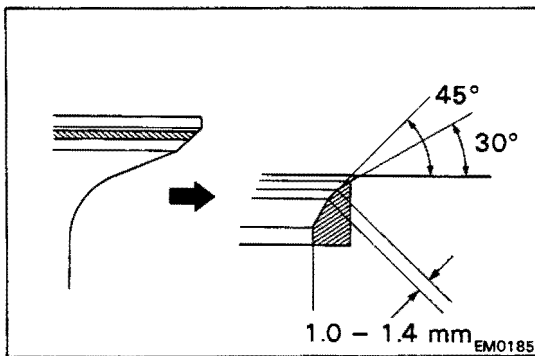

If not, correct the valve seats as follows:

- (1) If the seating is too high on the valve face, use 30° and 45° cutters to correct the seat.
- (2) If the seating is too low on the valve face, use 75° and 45° cutters to correct the seat.

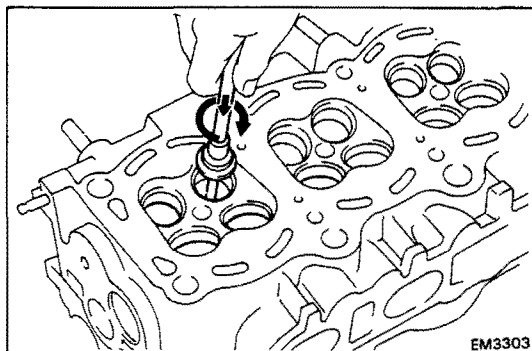

- (d) Hand-lap the valve and valve seat with an abrasive compound.
- (e) After hand-lapping, clean the valve and valve seat.

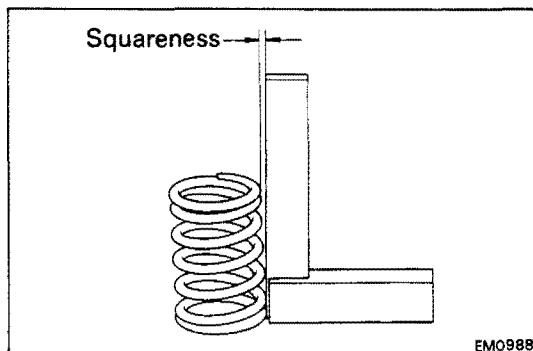

## 9. INSPECT VALVE SPRINGS

- (a) Using a steel square, measure the squareness of the valve spring.

**Maximum squareness: 2.0 mm (0.079 in.)**

If squareness is greater than maximum, replace the valve spring.

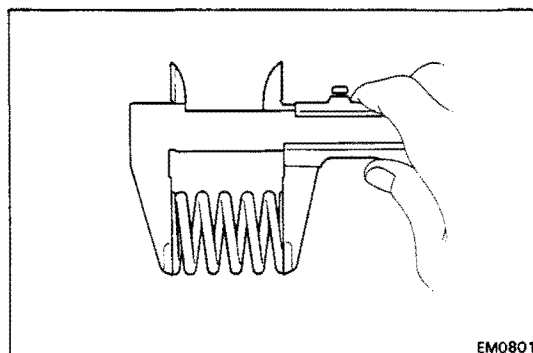

- (b) Using vernier calipers, measure the free length of the valve spring.

**Free length: 45.0 mm (1.772 in.)**

If the free length is not as specified, replace the valve spring.

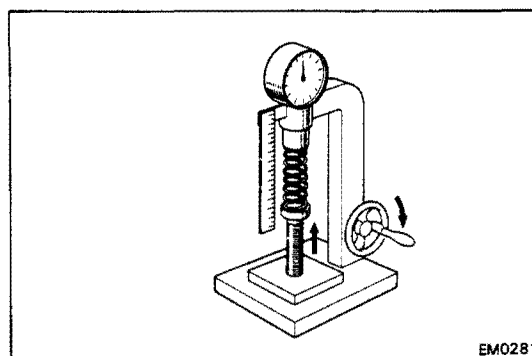

- (c) Using a spring tester, measure the tension of the valve spring at the specified installed length.

**Installed tension:**

**16.7 – 19.3 kg (36.8 – 42.5 lb, 164 – 189 N)  
at 34.7 mm (1.366 in.)**

If the installed tension is not as specified, replace the valve spring.

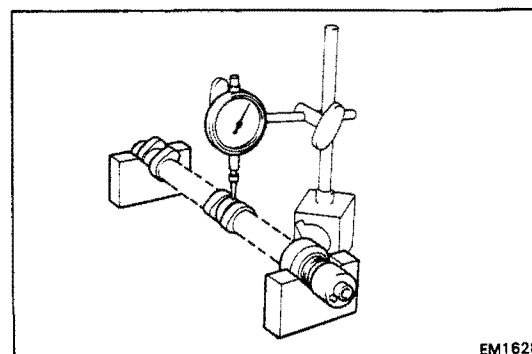

## 10. INSPECT CAMSHAFTS AND BEARINGS

### A. Inspect camshaft for runout

- (a) Place the camshaft on V-blocks.
- (b) Using a dial indicator, measure the circle runout at the center journal.

**Maximum circle runout: 0.04 mm (0.0016 in.)**

If the circle runout is greater than maximum, replace the camshaft.

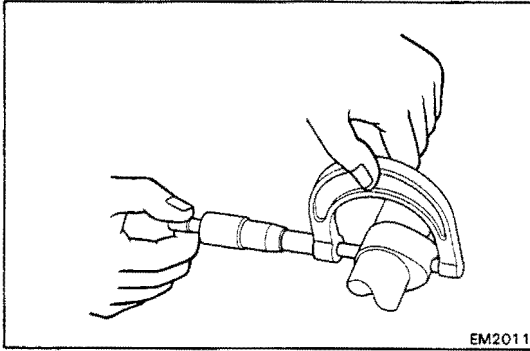
**B. Inspect cam lobes**

Using a micrometer, measure the cam lobe height.

**Standard cam lobe height:**

<b>Intake</b>	<b>35.310 – 35.410 mm</b> (1.3902 – 1.3941 in.)
<b>Exhaust</b>	<b>35.560 – 35.660 mm</b> (1.4000 – 1.4039 in.)

**Minimum cam lobe height:**

<b>Intake</b>	<b>35.20 mm (1.3858 in.)</b>
<b>Exhaust</b>	<b>35.45 mm (1.3957 in.)</b>

If the cam lobe height is greater than minimum, replace the camshaft.

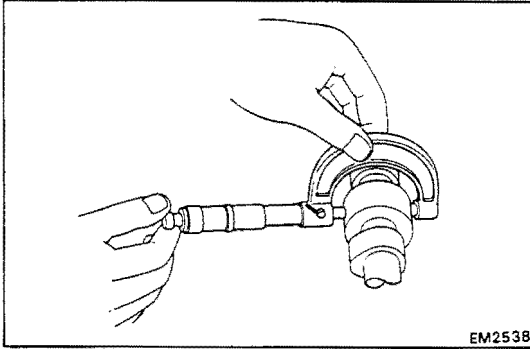
**C. Inspect camshaft journals**

Using a micrometer, measure the journal diameter.

**Journal diameter: 26.959 – 26.975 mm**  
(1.0614 – 1.0620 in.)

If the journal diameter is not as specified, check the oil clearance.

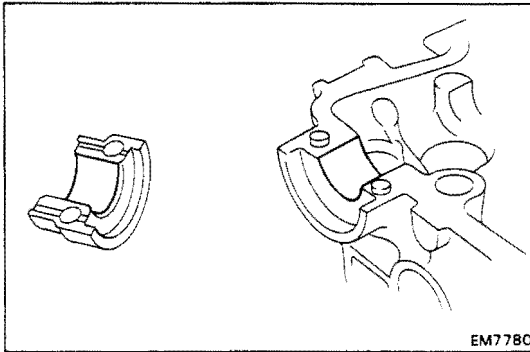
**D. Inspect camshaft bearings**

Check the bearings for flaking and scoring.

If the bearings are damaged, replace the bearing caps and cylinder head as a set.

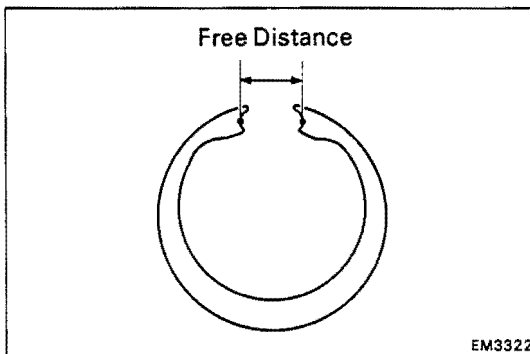
**E. Inspect camshaft gear spring**

Using vernier calipers, measure the free distance between the spring end.

**Free distance: 22.5 – 22.9 mm (0.886 – 0.902 in.)**

If the free distance is not as specified, replace the gear spring.

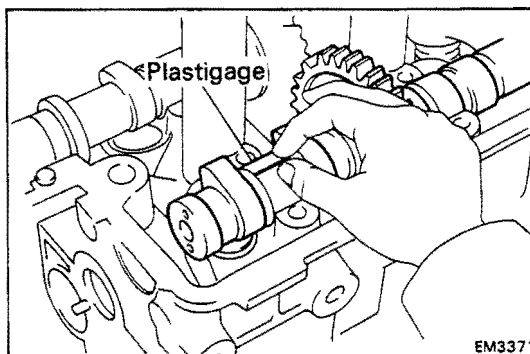
**F. Inspect camshaft journal oil clearance**

- Clean the bearing caps and camshaft journals.
- Place the camshafts on the cylinder head.
- Lay a strip of Plastigage across each of the camshaft journals.

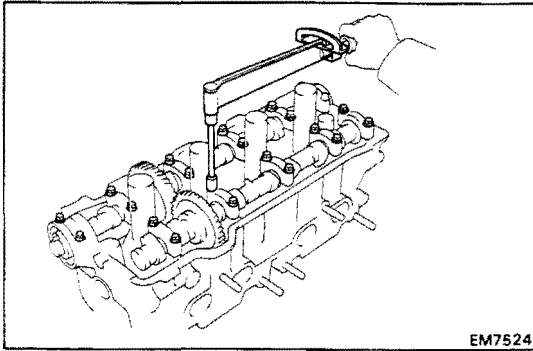

EM7524

- (d) Install the bearing caps.  
(See step 4 on pages EM-89 to 91)

**Torque: 190 kg-cm (14 ft-lb, 19 N·m)**

**NOTICE: Do not turn the camshaft.**

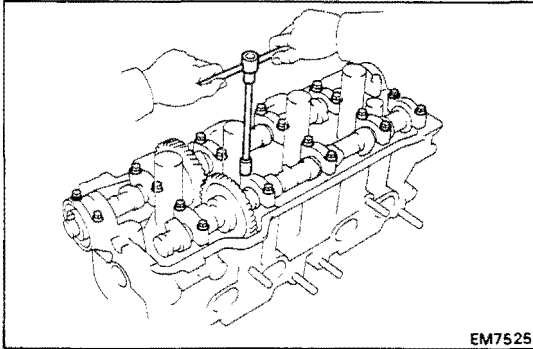

EM7525

- (e) Remove the bearing caps.

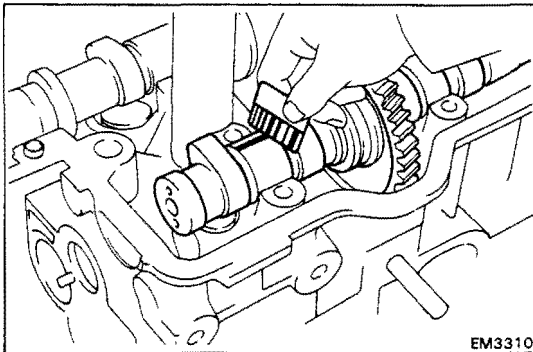

EM3310

- (f) Measure the Plastigage at its widest point.

**Standard oil clearance: 0.025 – 0.062 mm  
(0.0010 – 0.0024 in.)**

**Maximum oil clearance: 0.10 mm (0.0039 in.)**

If the oil clearance is greater than maximum, replace the camshaft. If necessary, replace the bearing caps and cylinder head as a set.

- (g) Completely remove the Plastigage.

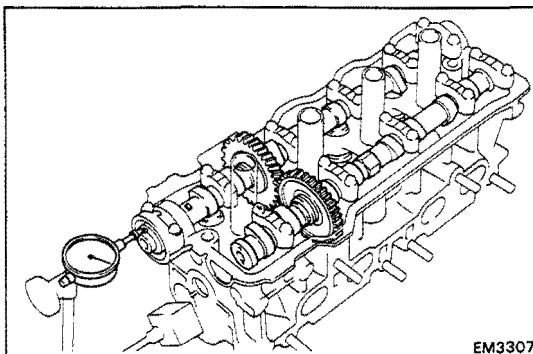

EM3307

### G. Inspect camshaft thrust clearance

- (a) Install the camshafts.  
(See step 4 on pages EM-89 to 91)
- (b) Using a dial indicator, measure the thrust clearance while moving the camshaft back and forth.

**Standard thrust clearance:**

**Intake 0.045 – 0.100 mm  
(0.0018 – 0.0039 in.)**

**Exhaust 0.030 – 0.085 mm  
(0.0012 – 0.0033 in.)**

**Maximum thrust clearance:**

**Intake 0.12 mm (0.0047 in.)**

**Exhaust 0.10 mm (0.0039 in.)**

If the thrust clearance is greater than maximum, replace the camshaft. If necessary, replace the bearing caps and cylinder head as a set.

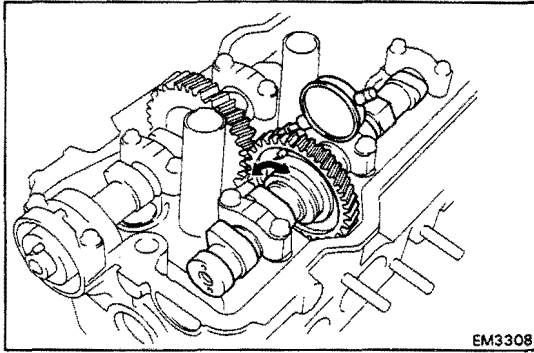

#### H. Inspect camshaft gear backlash

- (a) Install the camshafts without installing the exhaust cam sub-gear.  
(See step 4 on pages EM-89 to 91)
- (b) Using a dial indicator, measure the backlash.

**Standard backlash:** 0.020 – 0.200 mm  
(0.0008 – 0.0079 in.)

**Maximum backlash:** 0.30 mm (0.0188 in.)

If the backlash is greater than maximum, replace the camshafts.

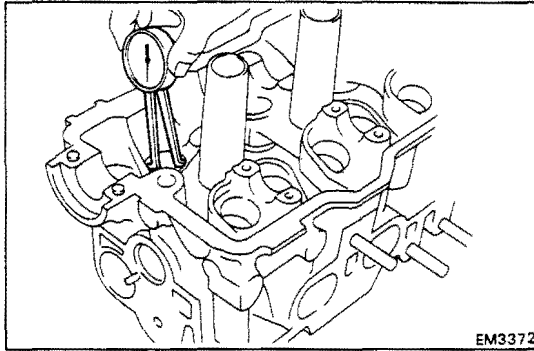

#### 11. INSPECT VALVE LIFTERS AND LIFTER BORES

- (a) Using a caliper gauge, measure the lifter bore diameter of the cylinder head.

**Lifter bore diameter:** 28.000 – 28.021 mm  
(1.1024 – 1.1032 in.)

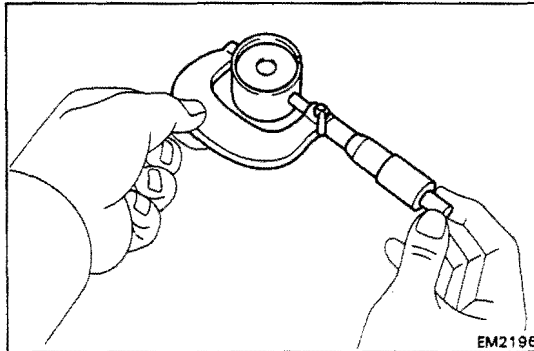

- (b) Using a micrometer, measure the lifter diameter.

**Lifter diameter:** 27.975 – 27.985 mm  
(1.1014 – 1.1018 in.)

- (c) Subtract the lifter diameter measurement from the lifter bore diameter measurement.

**Standard oil clearance:** 0.015 – 0.046 mm  
(0.0005 – 0.0018 in.)

**Maximum oil clearance:** 0.07 mm (0.0028 in.)

If the oil clearance is greater than maximum, replace the lifter. If necessary, replace the cylinder head.

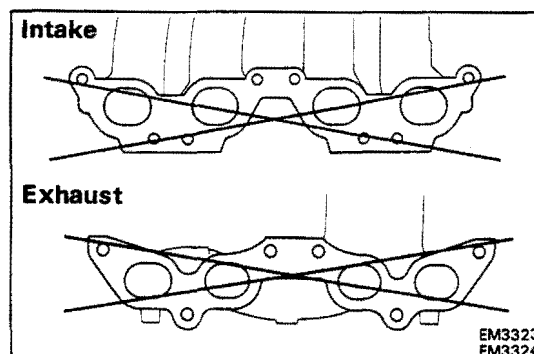

#### 12. INSPECT INTAKE AND EXHAUST MANIFOLDS

Using precision straight edge and feeler gauge, measure the surface contacting the cylinder head for warpage.

**Maximum warpage:** 0.30 mm (0.0118 in.)

If warpage is greater than maximum, replace the manifold.

**ASSEMBLY OF CYLINDER HEAD**

(See page EM-64)

**HINT:**

- Thoroughly clean all parts to be assembled.
- Before installing the parts, apply new engine oil to all sliding and rotating surfaces.
- Replace all gaskets and oil seals with new ones.

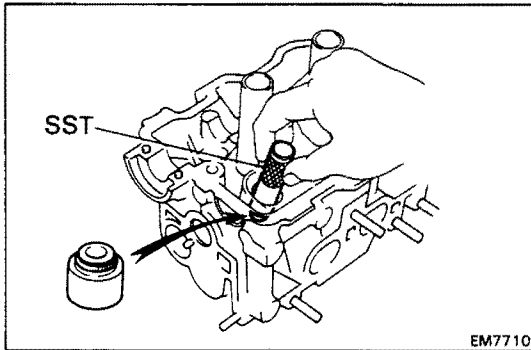
**1. INSTALL VALVES**

(a) Using SST, push in a new oil seal.

SST 09201-41020

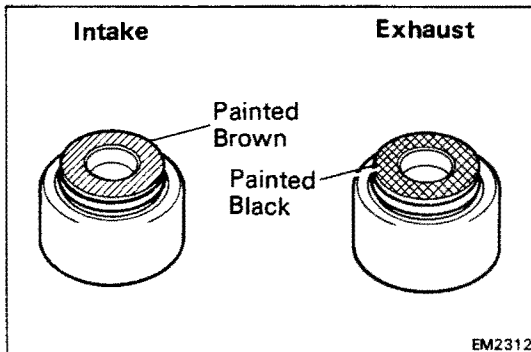
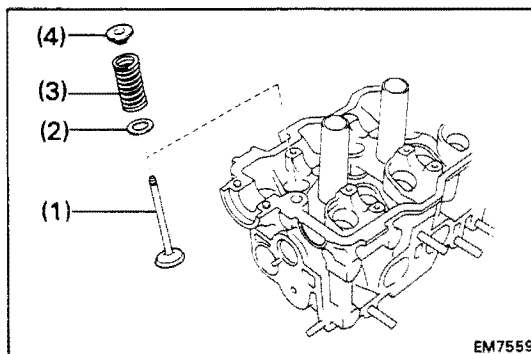
**HINT:** The intake valve oil seal is brown and the exhaust valve oil seal is black.

(b) Install the following parts:

- (1) Valve
- (2) Spring seat
- (3) Valve spring
- (4) Spring retainer

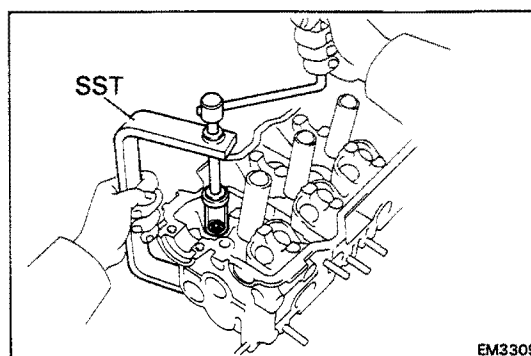

(c) Using SST, compress the valve spring and place the two keepers around the valve stem.

SST 09202-70010

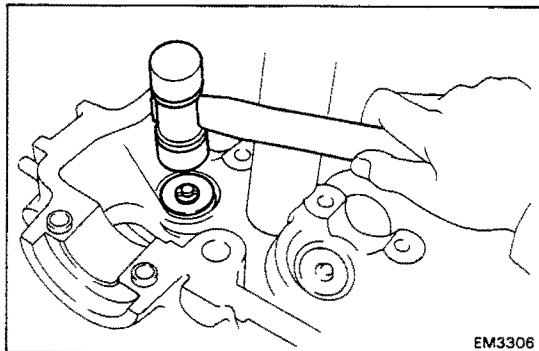

- (d) Using a plastic-faced hammer, lightly tap the valve stem tip to assure proper fit.

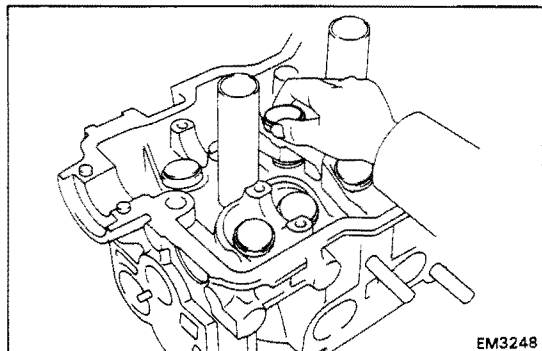

## 2. INSTALL VALVE LIFTERS AND SHIMS

- (a) Install the valve lifter and shim.  
(b) Check that the valve lifter rotates smoothly by hand.

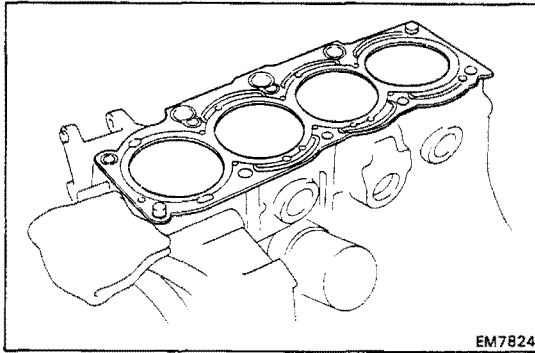

## INSTALLATION OF CYLINDER HEAD

(See page EM-64)

### 1. INSTALL CYLINDER HEAD

#### A. Place cylinder head on cylinder block

- (a) Place a new cylinder head gasket in position on the cylinder block.

**NOTICE:** Be careful of the installation direction.

- (b) Place the cylinder head in position on the cylinder head gasket.

#### B. Install cylinder head bolts

HINT:

- The cylinder head bolts are tightened in two progressive steps (steps (b) and (d)).
  - If any cylinder head bolt is broken or deformed, replace it.
- (a) Apply a light coat of engine oil on the threads and under the heads of the cylinder head bolts.
- (b) Using SST, install and uniformly tighten the ten cylinder head bolts in several passes in the sequence shown.

SST 09011-38121

**Torque: 500 kg-cm (36 ft-lb, 47 N-m)**

If any one of the cylinder head bolts does not meet the torque specification, replace the cylinder head bolt.

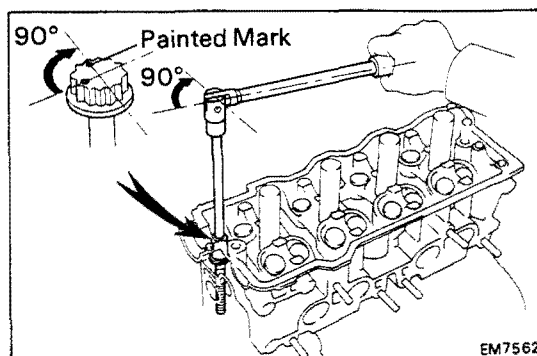
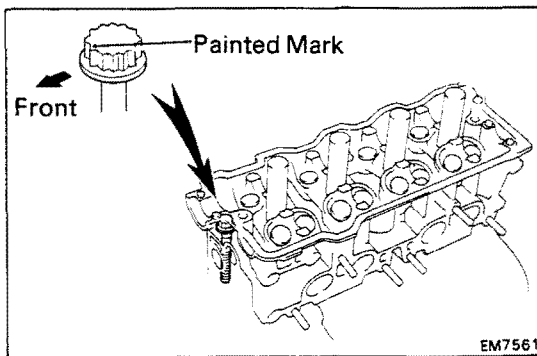
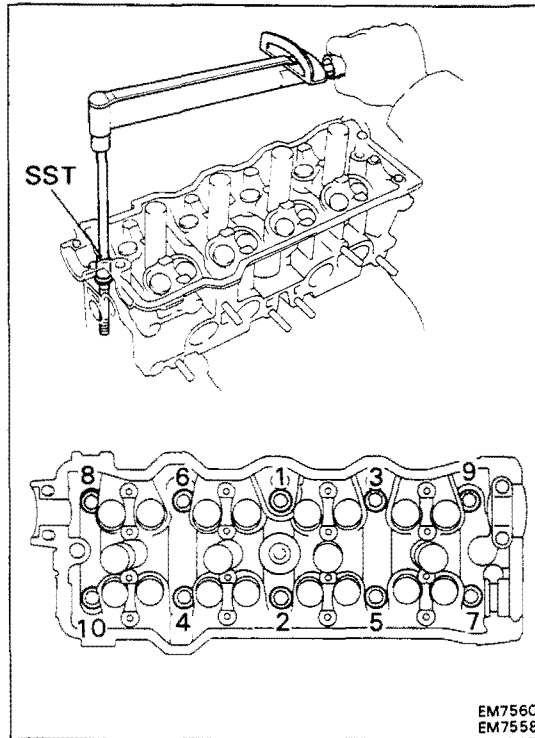

- (c) Mark the front of the cylinder head bolt head with paint.

- (d) Retighten the cylinder head bolts 90° in the numerical order shown.

- (e) Check that the painted mark is now at a 90° angle to front.



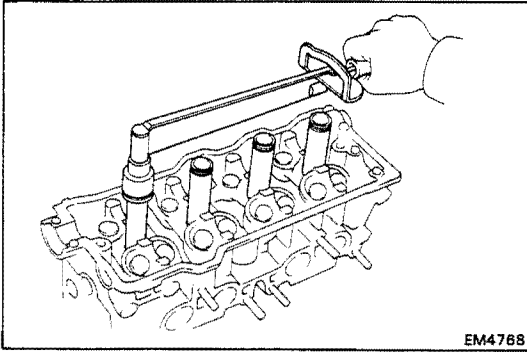

## 2. INSTALL SPARK PLUG TUBES

- Clean the cylinder head tube holes of any residual adhesive, oil or foreign particles. Remove any oil with kerosene or gasoline.
- Screw the threads of the spark plug tube coated with adhesive into the cylinder head.
- Using the spark plug tube nut and a 30 mm socket wrench, tighten the spark plug tubes.

**Torque: 400 kg-cm (29 ft-lb, 39 N·m)**

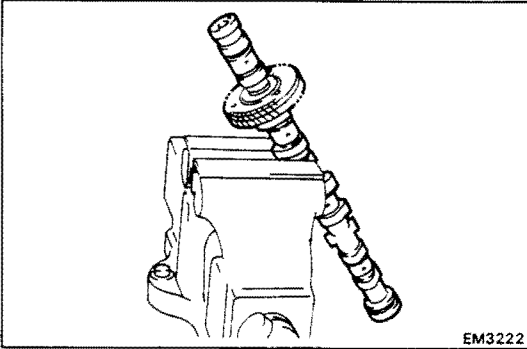

## 3. ASSEMBLE EXHAUST CAMSHAFT

- Mount the hexagonal wrench head portion of the camshaft in a vise.

**NOTICE: Be careful not to damage the camshaft.**

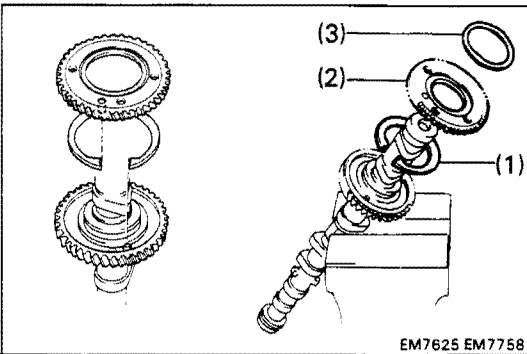

- Install the following parts:

- Camshaft gear spring
- Camshaft sub-gear
- Wave washer

**HINT: Align the pins on the gears with the spring ends.**

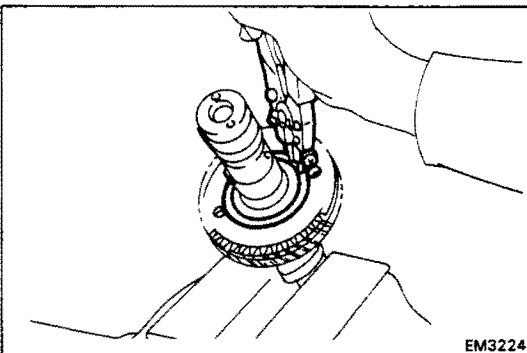

- Using snap ring pliers, install the snap ring.

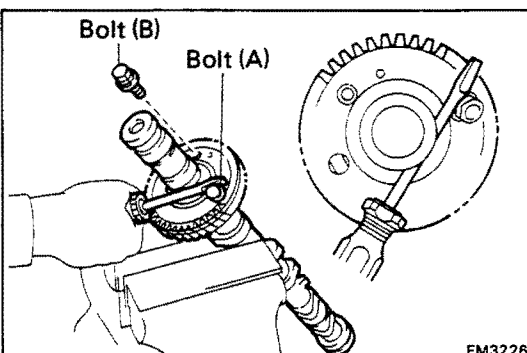

- Insert a service bolt (A) into the service hole of the camshaft sub-gear.

- Using a screwdriver, align the holes of the camshaft main gear and sub-gear by turning camshaft sub-gear clockwise, and install a service bolt (B).

**NOTICE: Be careful not to damage the camshaft.**

#### 4. INSTALL CAMSHAFTS

**NOTICE:** Since the thrust clearance of the camshaft is small, the camshaft must be kept level while it is being installed. If the camshaft is not kept level, the portion of the cylinder head receiving the shaft thrust may crack or be damaged, causing the camshaft to seize or break. To avoid this, the following steps should be carried out.

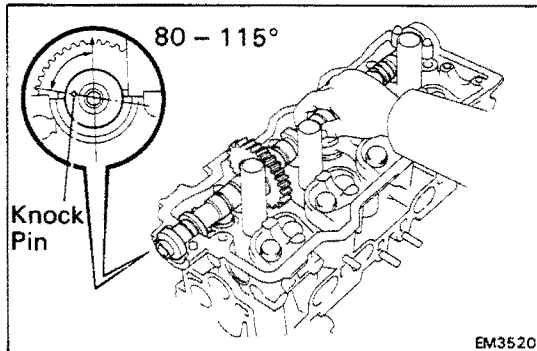

##### A. Install intake camshaft

- (a) Apply MP grease to the thrust portion of the camshaft.
- (b) Place the intake camshaft at 80 – 115TDC of camshaft angle on the cylinder head.

**HINT:** The above angle arrows the No.1 and No.3 cylinder cam lobes of the intake camshaft to push their valve lifters evenly.

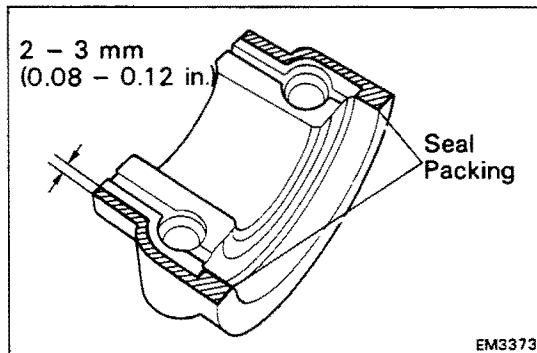

- (c) Apply seal packing to the No.1 bearing cap as shown.  
**Seal packing: Part No. 08826-00080 or equivalent**

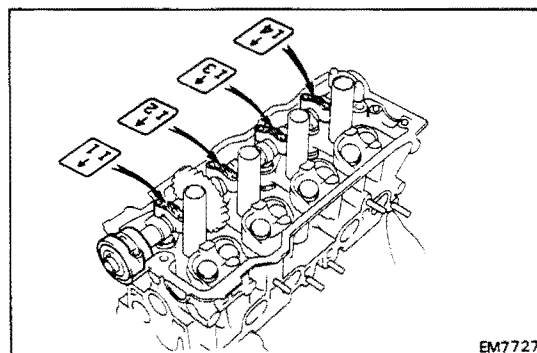

- (d) Install the bearing caps in their proper locations.

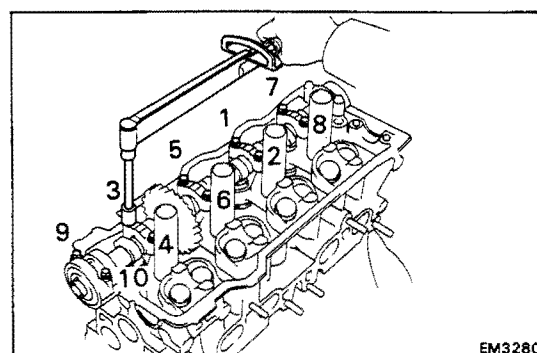

- (e) Apply a light coat of engine oil on the threads and under the heads of the bearing cap bolts.
- (f) Install and uniformly tighten the ten bearing cap bolts in several passes in the sequence shown.

**Torque: 190 kg-cm (14 ft-lb, 19 N·m)**

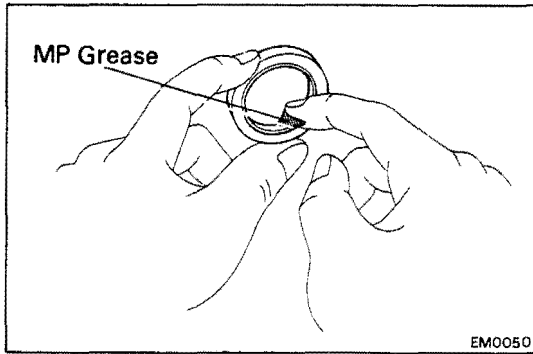

(g) Apply MP grease to a new oil seal lip.

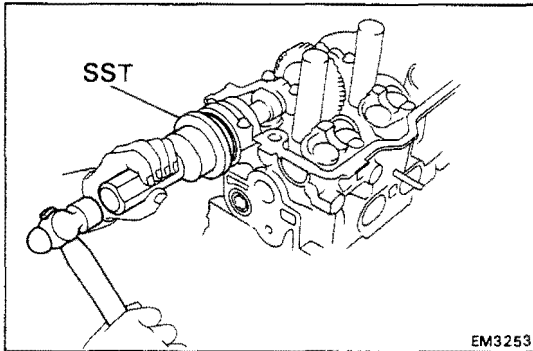

(h) Using SST, tap in the oil seal.  
SST 09223-46011

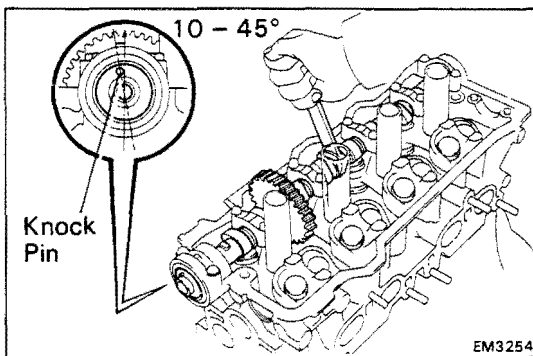

## B. Install exhaust camshaft

(a) Set the knock pin of the intake camshaft at 10 - 45° BTDC of camshaft angle.

HINT: The above angle arrows show the No.2 and No.4 cylinder cam lobes of the exhaust camshaft to push their valve lifters evenly.

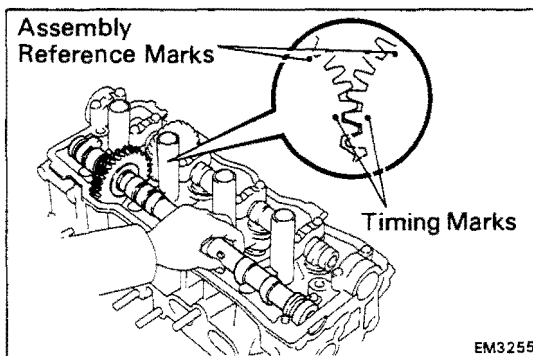

- (b) Apply MP grease to the thrust portion of the camshaft.
- (c) Engage the exhaust camshaft gear to the intake camshaft gear by matching the timing marks on each gear.
- (d) Roll down the exhaust camshaft onto the bearing journals while engaging gears with each other.

**NOTICE:** There are also assembly reference marks on each gear as shown in the illustration. Do not use these marks.

(e) Turn the intake camshaft clockwise or counterclockwise little by little until the exhaust camshaft sits in the bearing journals evenly without rocking the camshaft on the bearing journals.

**NOTICE:** It is very important to replace the camshaft in the bearing journals evenly while tightening bearing caps in the subsequent steps.

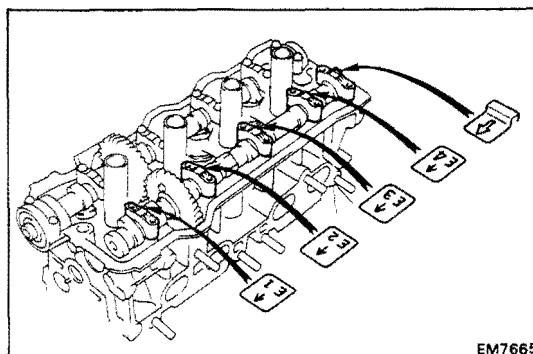

(f) Install the bearing caps in their proper location.

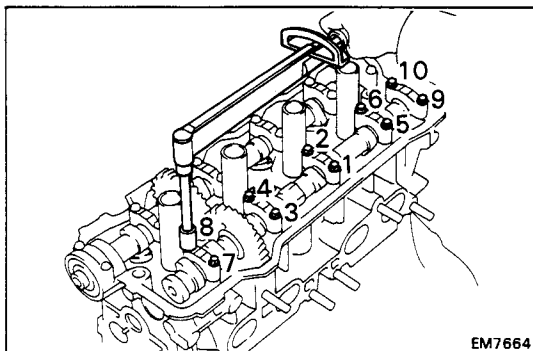

EM7664

- (g) Apply a light coat of engine oil on the threads and under the heads of the bearing cap bolts.
- (h) Install and uniformly tighten the ten bearing cap bolts in several passes in the sequence shown.

**Torque: 190 kg-cm (14 ft-lb, 19 N·m)**

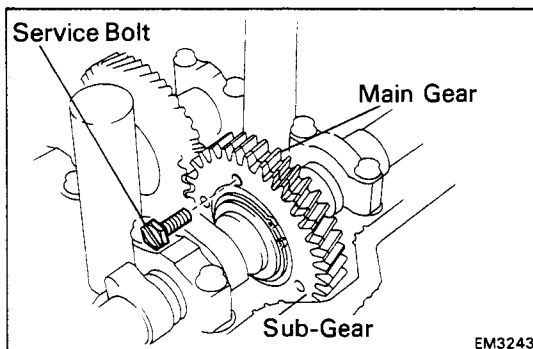

EM3243

- (i) Remove the service bolt (B).

## 5. CHECK AND ADJUST VALVE CLEARANCE (See page EM-13)

Turn the camshaft and position the cam lobe upward, and check and adjust the valve clearance.

**Valve clearance (Cold):**

Intake 0.19 – 0.29 mm (0.007 – 0.011 in.)

Exhaust 0.28 – 0.38 mm (0.011 – 0.015 in.)

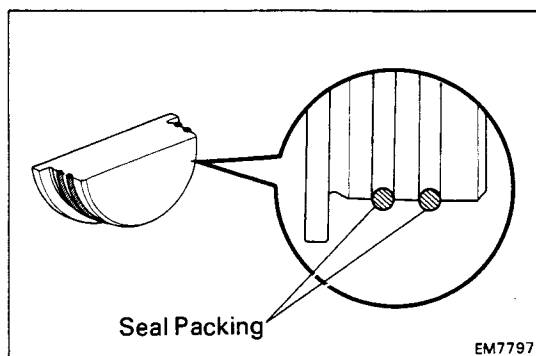

EM7797

## 6. INSTALL SEMI-CIRCULAR PLUGS

- (a) Remove any old packing (FIPG) material.
  - (b) Apply seal packing to the semi-circular plug groove.
- Seal packing: Part No. 08826-00080 or equivalent**

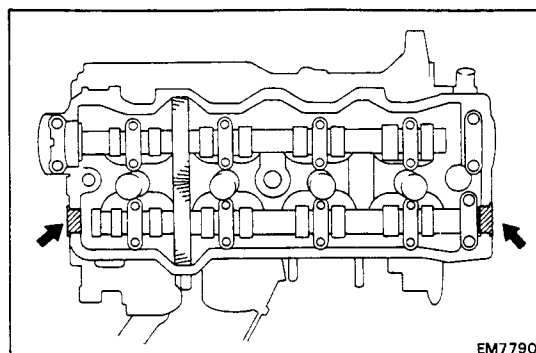

EM7790

- (c) Install the two semi-circular plugs to the cylinder head.

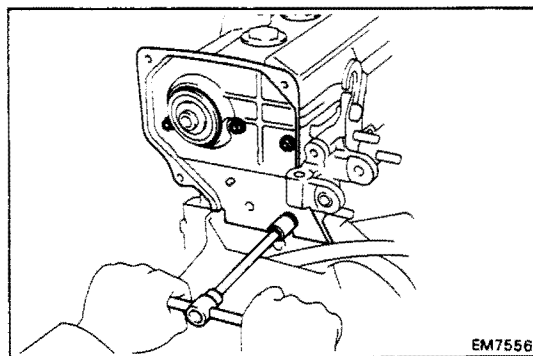
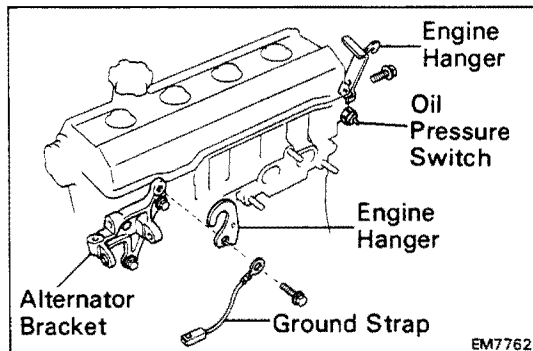
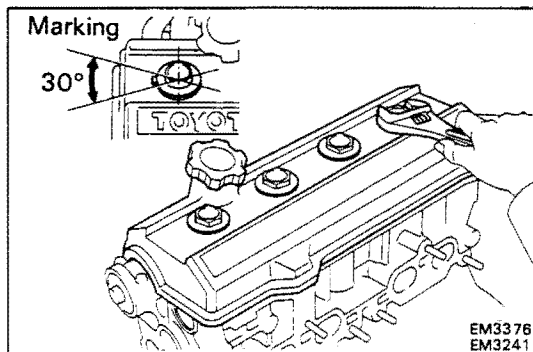
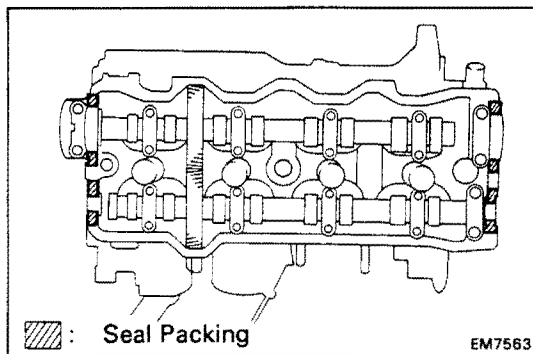

## 7. INSTALL CYLINDER HEAD COVER

- (a) Remove any old packing (FIPG) material.
- (b) Apply seal packing to the cylinder head as shown in the figure.

**Seal packing: Part No. 08826-00080 or equivalent**

- (c) Install the gasket to the head cover.
- (d) Install the head cover with the four grommets and nuts. Uniformly tighten the nuts in several passes.

**Torque: 180 kg-cm (13 ft-lb, 18 N·m)**

**HINT:** Install the grommets so that its markings are as shown in the illustration. Then install the grommet to its original position.

## 8. INSTALL OIL PRESSURE SWITCH

Apply adhesive to two or three threads.

**Adhesive: Part No. 08833-00080, THREE BOND 1324 or equivalent**

## 9. INSTALL ALTERNATOR BRACKET

Install the alternator bracket with the three bolts.

**Torque: 425 kg-cm (31 ft-lb, 42 N·m)**

## 10. INSTALL ENGINE HANGERS

Install the engine hanger with the bolt. Install the two engine hangers. Install the ground strap.

**Torque: 250 kg-cm (18 ft-lb, 25 N·m)**

## 11. INSTALL NO.3 TIMING BELT COVER

Install the timing belt cover with the four bolts.

**Torque: 80 kg-cm (69 in.-lb, 7.8 N·m)**

## 12. INSTALL NO.1 IDLER PULLEY AND TENSION SPRING (See step 4 on page EM-40)

## 13. INSTALL CAMSHAFT TIMING PULLEY (See steps 9 to 16 on pages EM-41 to 44)

## 14. INSTALL INJECTOR AND DELIVERY PIPE (See steps 1, 2 and 4 on pages FI-138 to 140)

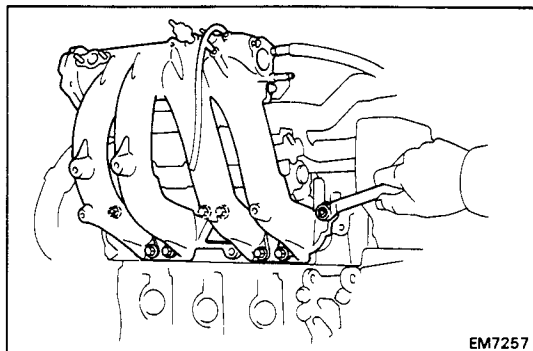
**15. INSTALL INTAKE MANIFOLD**

- (a) Install a new gasket and the intake manifold with the six bolts and two nuts. Uniformly tighten the bolts and nuts in several passes.

**Torque: 195 kg-cm (14 ft-lb, 19 N·m)**

- (b) Connect the vacuum sensing hose.

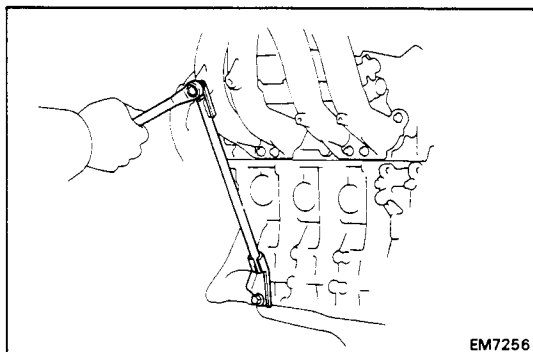

- (c) Install the manifold stay with the two bolts.

**Torque:**

**12 mm head bolt 195 kg-cm (14 ft-lb, 19 N·m)**

**14 mm head bolt 425 kg-cm (31 ft-lb, 42 N·m)**

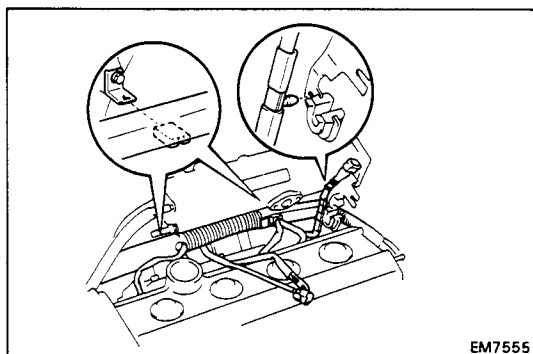

- (d) Connect the two wire clamps to the wire bracket.

- (e) Connect the wire clip to the accelerator bracket.

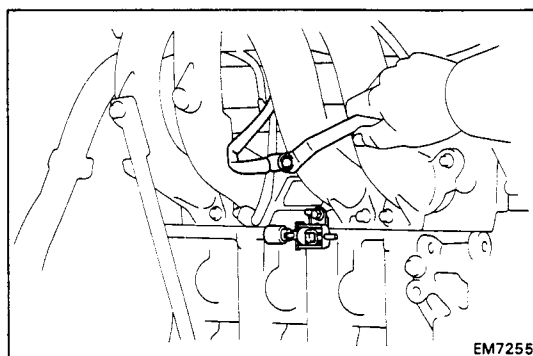
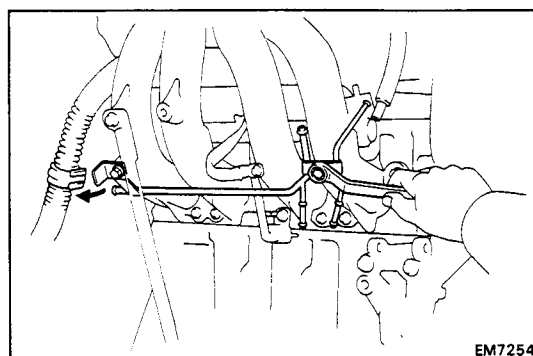
**16. INSTALL EGR VSV****17. INSTALL ENGINE WIRE GROUND STRAP TO INTAKE MANIFOLD****18. INSTALL AIR TUBE**

- (a) Install the air tube and wire bracket with the two bolts.

- (b) Connect the engine wire clamp to the engine wire.

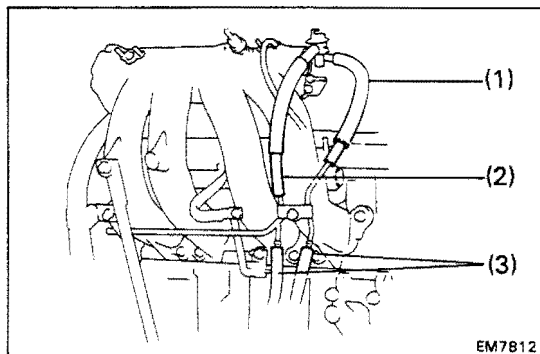

- (c) Connect the following hoses:
- (1) Air hose (from intake manifold)
  - (2) (w/ A/C)  
Air hose (from A/C ASV)
  - (3) Two air hose (from PS pump)

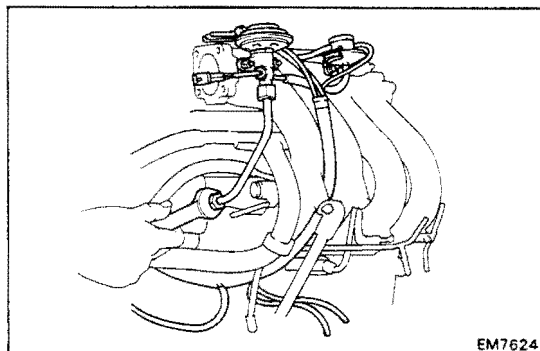

#### 19. INSTALL EGR VALVE AND VACUUM MODULATOR

- (a) Install a new gasket and the EGR valve with the union nut and two bolts.

##### Torque:

Union nut 600 kg-cm (43 ft-lb, 59 N·m)  
Bolt 130 kg-cm (9 ft-lb, 13 N·m)

- (b) Install the EGR modulator to the clamp.

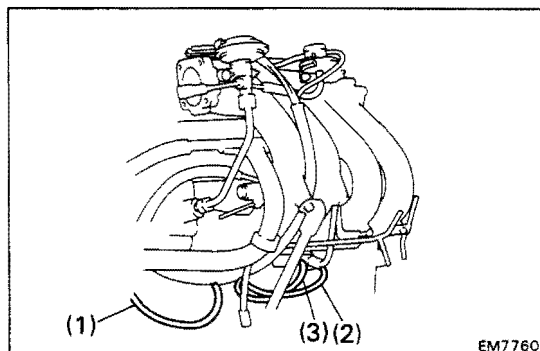

- (c) Connect the following hoses:
- (1) Vacuum hose (from Q port of EGR vacuum modulator) to G port of EGR VSV
  - (2) Vacuum hose (from EGR valve) to E port of EGR VSV
  - (3) Vacuum hose to charcoal canister

#### 20. INSTALL COLD START INJECTOR (See steps 1 and 3 on page FI-120)

#### 21. INSTALL COLD START INJECTOR PIPE (See step 2 on page FI-120)

#### 22. INSTALL THROTTLE BODY (See steps 2 to 5 on page FI-162)

#### 23. INSTALL WATER BY-PASS PIPE

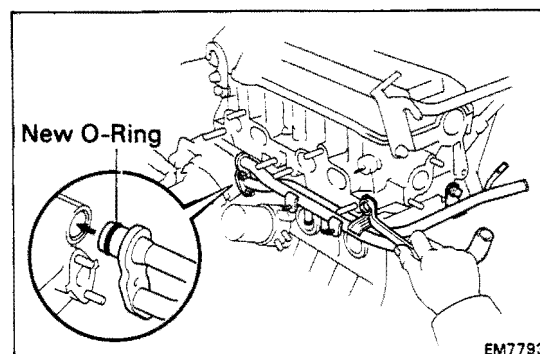

- (a) Install a new O-ring to the by-pass pipe.
- (b) Apply soapy water on the O-ring.
- (c) Install a new gasket and the by-pass pipe with the two nuts and two bolts.

Torque(Nut): 95 kg-cm (82 in.-lb, 9.3 N·m)

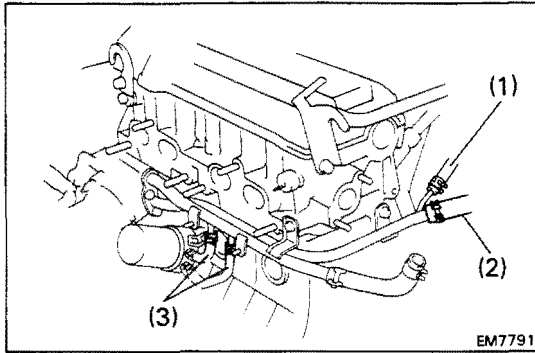

- (d) Connect the following hoses:
- (1) ISC water by-pass hose
  - (2) Heater water hose
  - (3) (w/ Oil Cooler)  
Two oil cooler water by-pass hoses
- (e) (w/ Oil Cooler)  
Install the oil cooler heat protector.  
(See steps 3 on page LU-18)

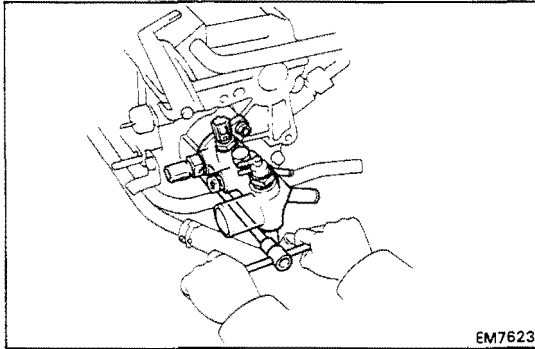

#### 24. INSTALL WATER OUTLET

- (a) Install a new gasket and the water outlet with the two bolts.

**Torque: 150 kg-cm (11 ft-lb, 15 N·m)**

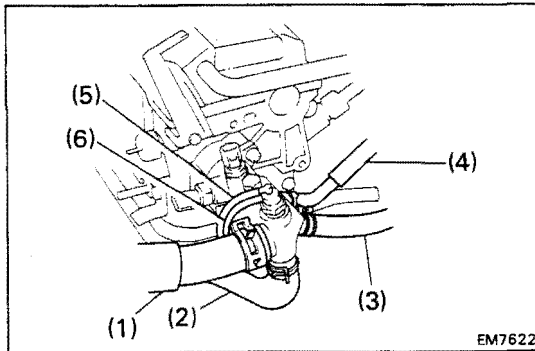

- (b) Connect the following hoses:
- (1) Upper radiator hose
  - (2) Water by-pass pipe hose
  - (3) Heater water hose
  - (4) ISC water by-pass hose
  - (5) EVAP BVSV vacuum hose (from P port of throttle body)
  - (6) EVAP BVSV vacuum hose (from charcoal canister)
- (c) Connect the following connectors:
- Water temperature sender gauge connector
  - Water temperature sensor connector
  - Cold start injector time switch connector

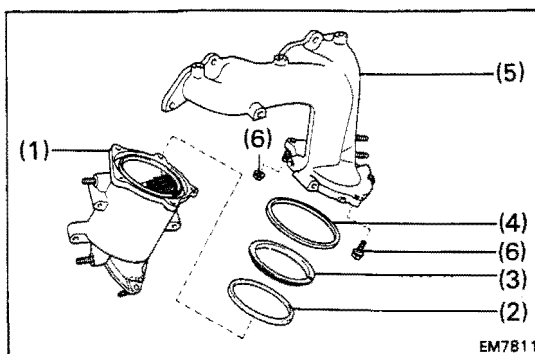

#### 25. ASSEMBLE EXHAUST MANIFOLD AND CATALYTIC CONVERTER

Assemble the following parts:

- (1) Catalytic converter
- (2) Cushion
- (3) Retainer
- (4) Gasket
- (5) Exhaust manifold
- (6) Three bolts and two nuts

**Torque: 300 kg-cm (22 ft-lb, 29 N·m)**



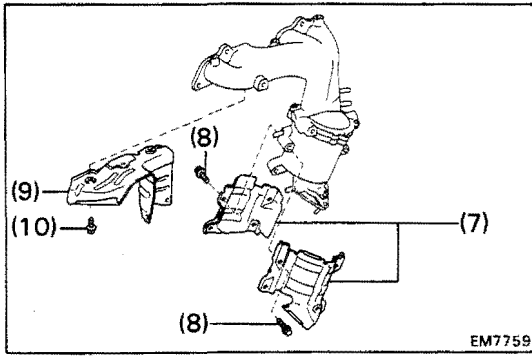

- (7) Two converter heat insulators
- (8) Eight bolts
- (9) Manifold lower heat insulator
- (10) Five bolts

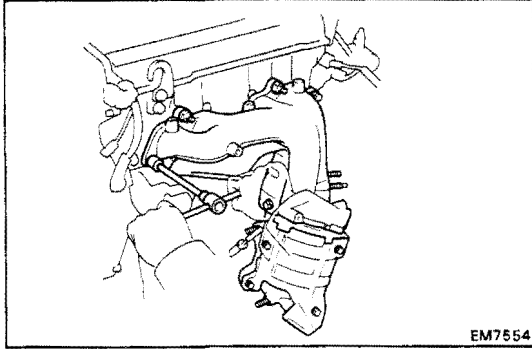

## 26. INSTALL EXHAUST MANIFOLD AND CATALYTIC CONVERTER ASSEMBLY

- (a) Install a new gasket, the exhaust manifold and catalytic converter assembly with the six new nuts. Uniformly tighten the nuts in several passes.

**Torque: 500 kg-cm (36 ft-lb, 49 N·m)**

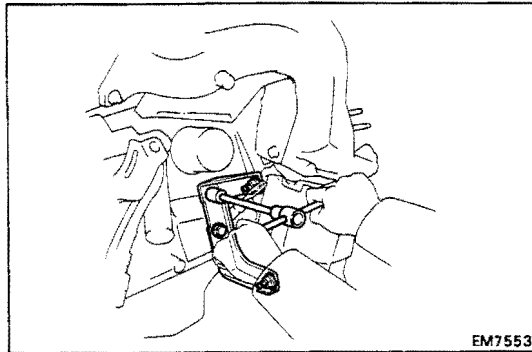

- (b) Install the catalytic converter stay with the two bolts and two new nuts.

**Torque: 425 kg-cm (31 ft-lb, 42 N·m)**

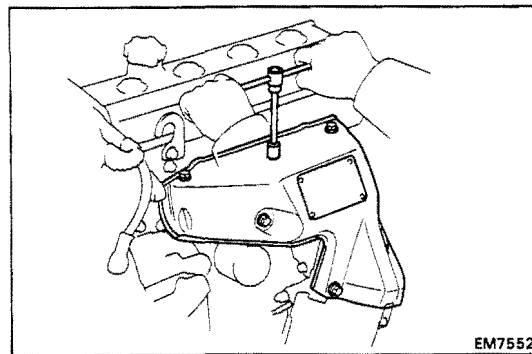

- (c) Install the manifold upper heat insulator with the six bolts.

- (d) Connect the main oxygen sensor connector.

## 27. INSTALL DISTRIBUTOR (See steps 1 to 4 on page IG-14)

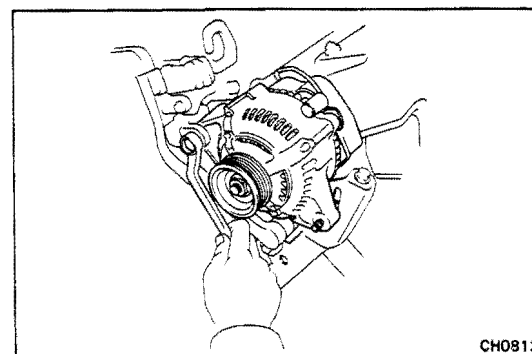

## 28. INSTALL ALTERNATOR

- (a) Mount the alternator on the alternator brackets with the pivot bolt and adjusting lock bolt.
- (b) Install the drive belt.
- (c) Connect the alternator connector.
- (d) Connect the alternator wire with the nut.

**29. FILL WITH ENGINE COOLANT**

**30. START ENGINE AND CHECK FOR LEAKS**

**31. ADJUST IGNITION TIMING (See page EM-14)**

Ignition timing:

**10° BTDC @ idle**

**(w/ Terminals TE1 and E1 connected)**

**32. RECHECK ENGINE COOLANT LEVEL AND OIL LEVEL**

# CYLINDER HEAD (3S-GE and 3S-GTE) COMPONENTS (3S-GE)

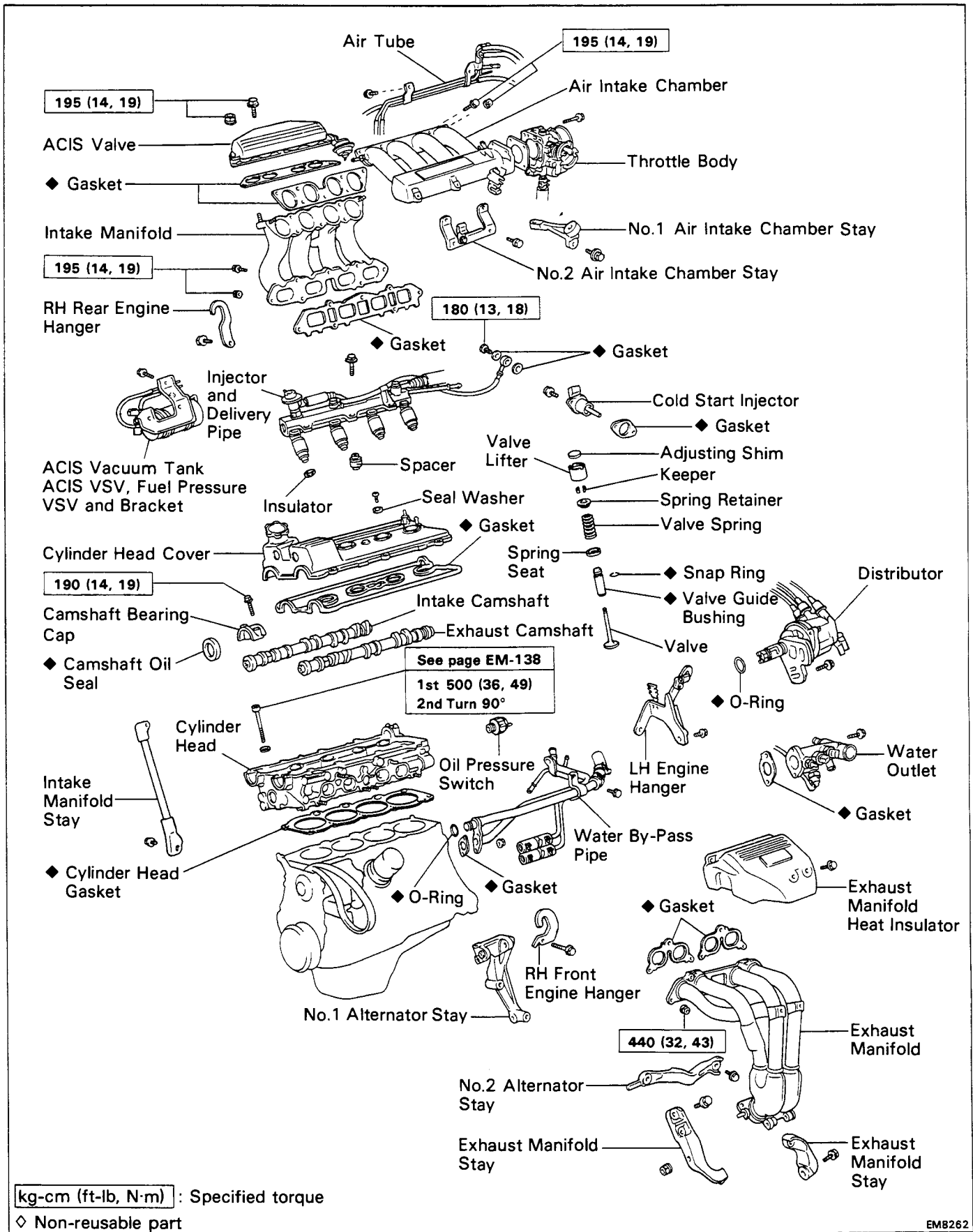

COMPONENTS (3S-GTE)

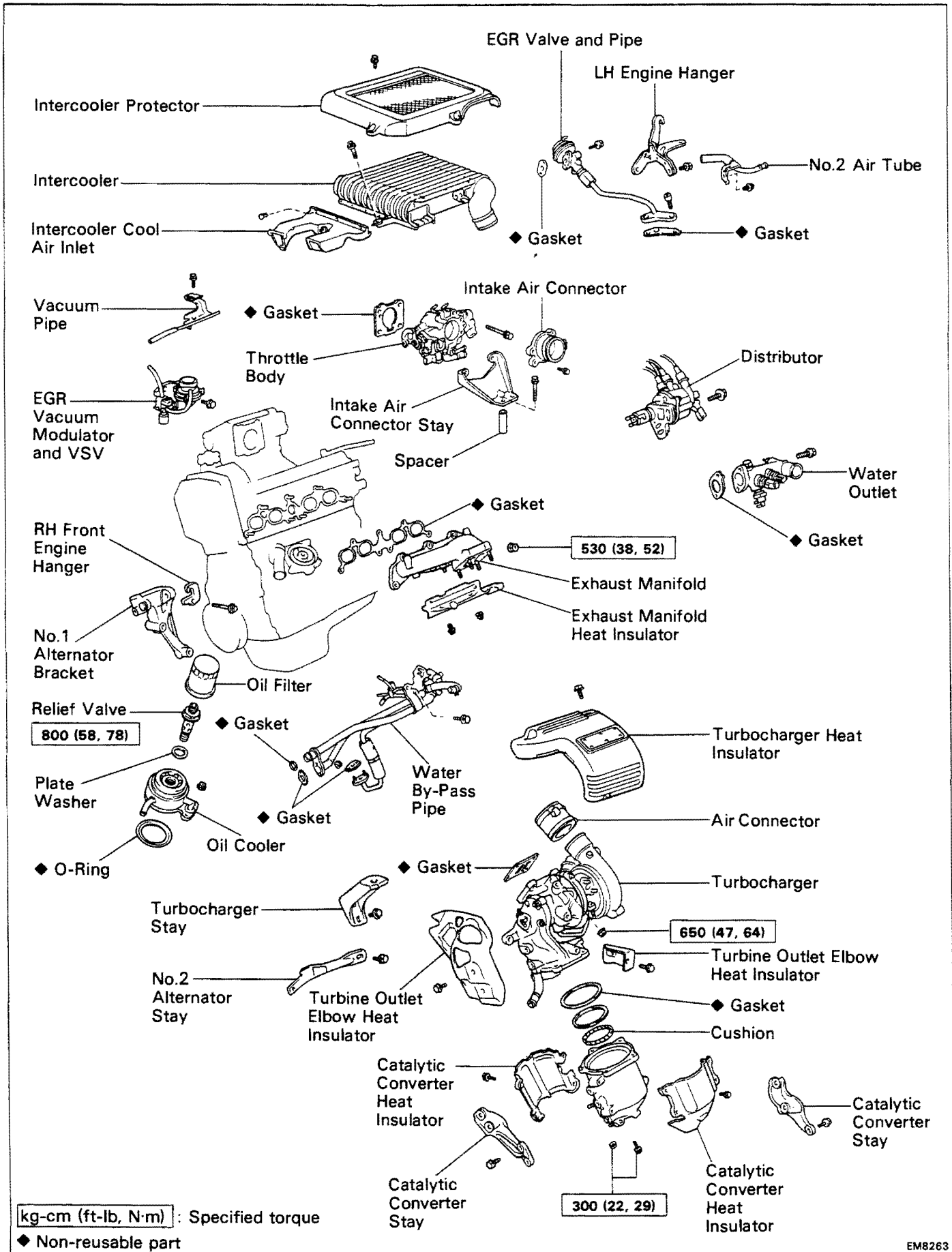

COMPONENTS (3S-GTE) (Cont'd)

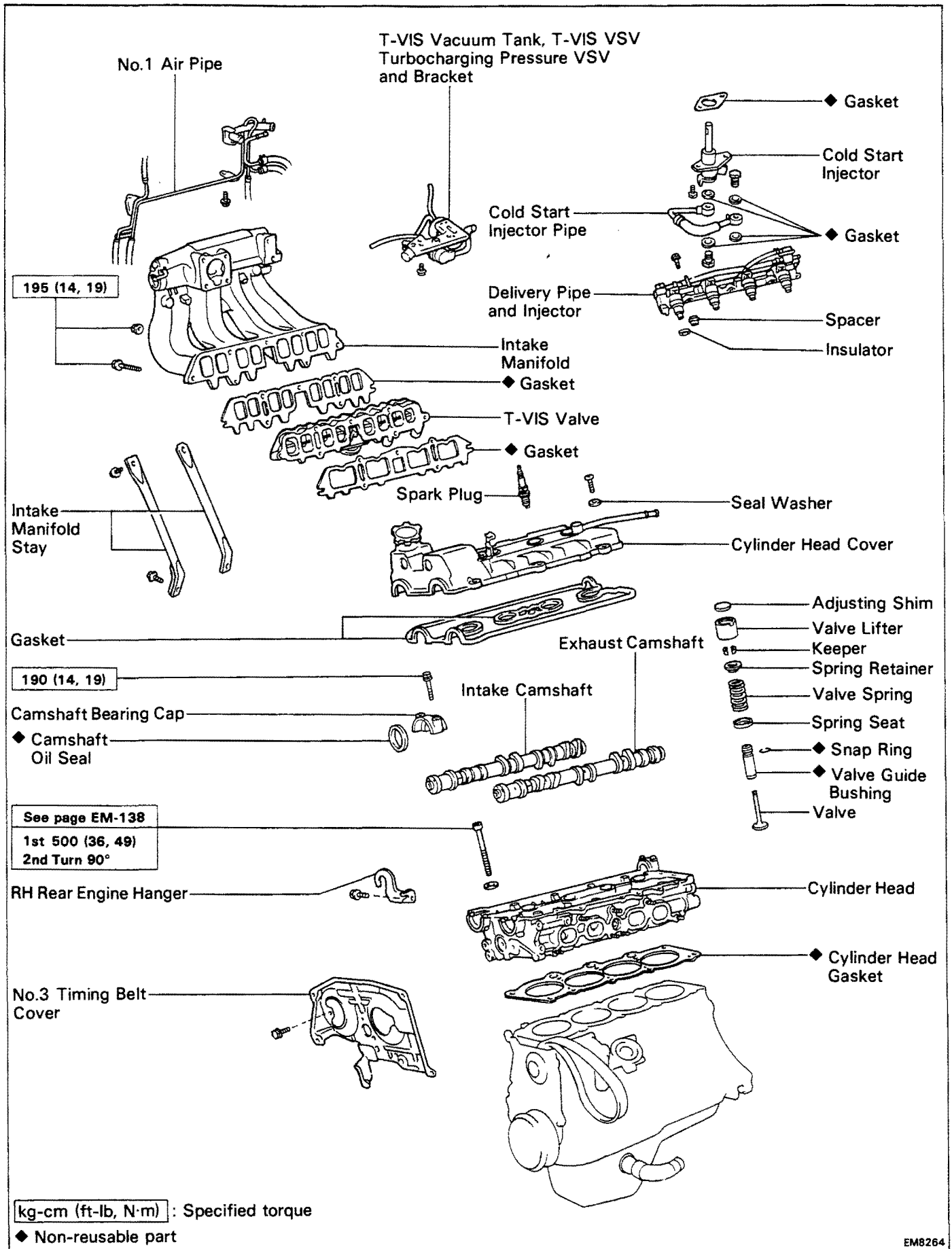

# CYLINDER HEAD (3S-GTE) COMPONENTS

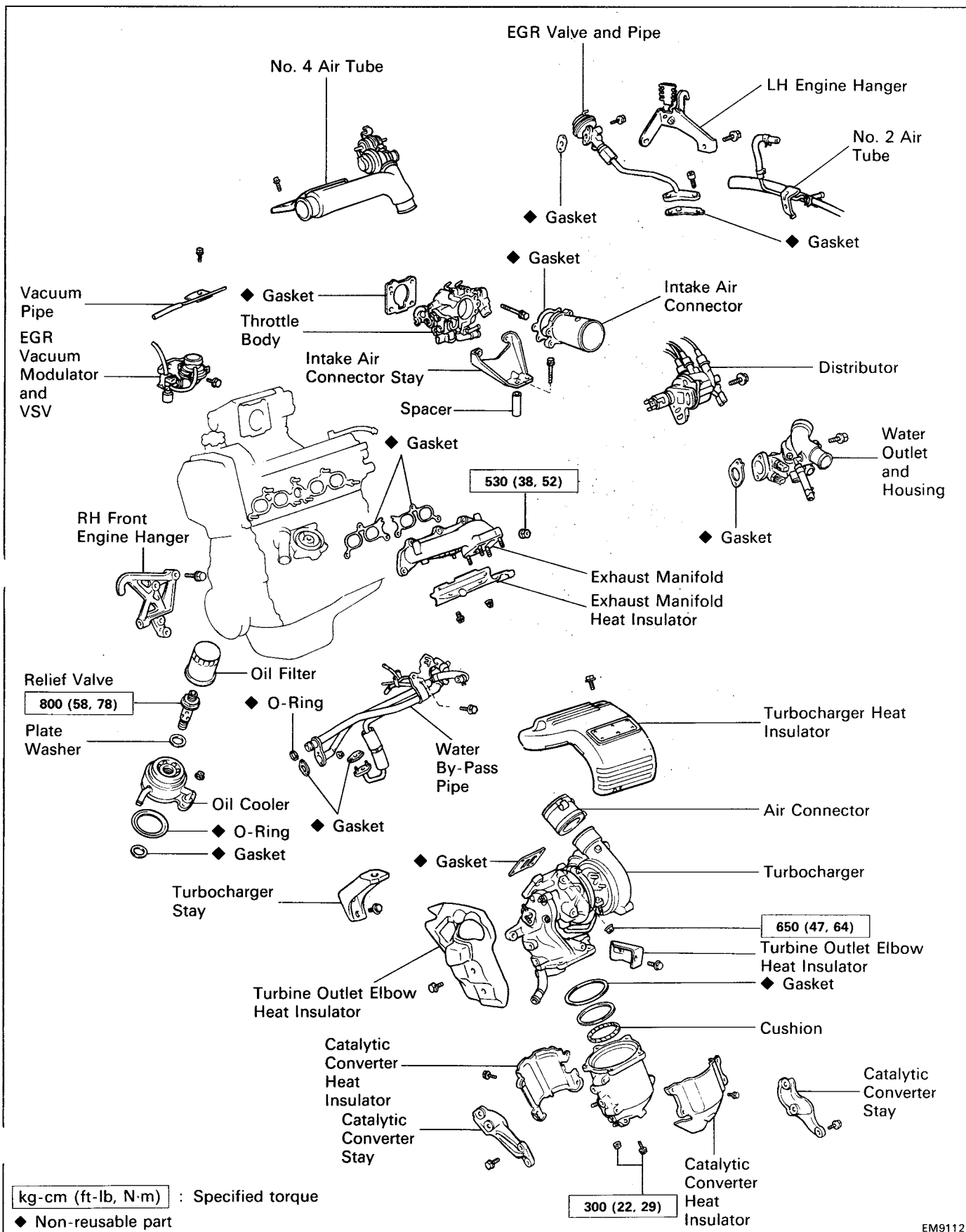

COMPONENTS (Cont'd)

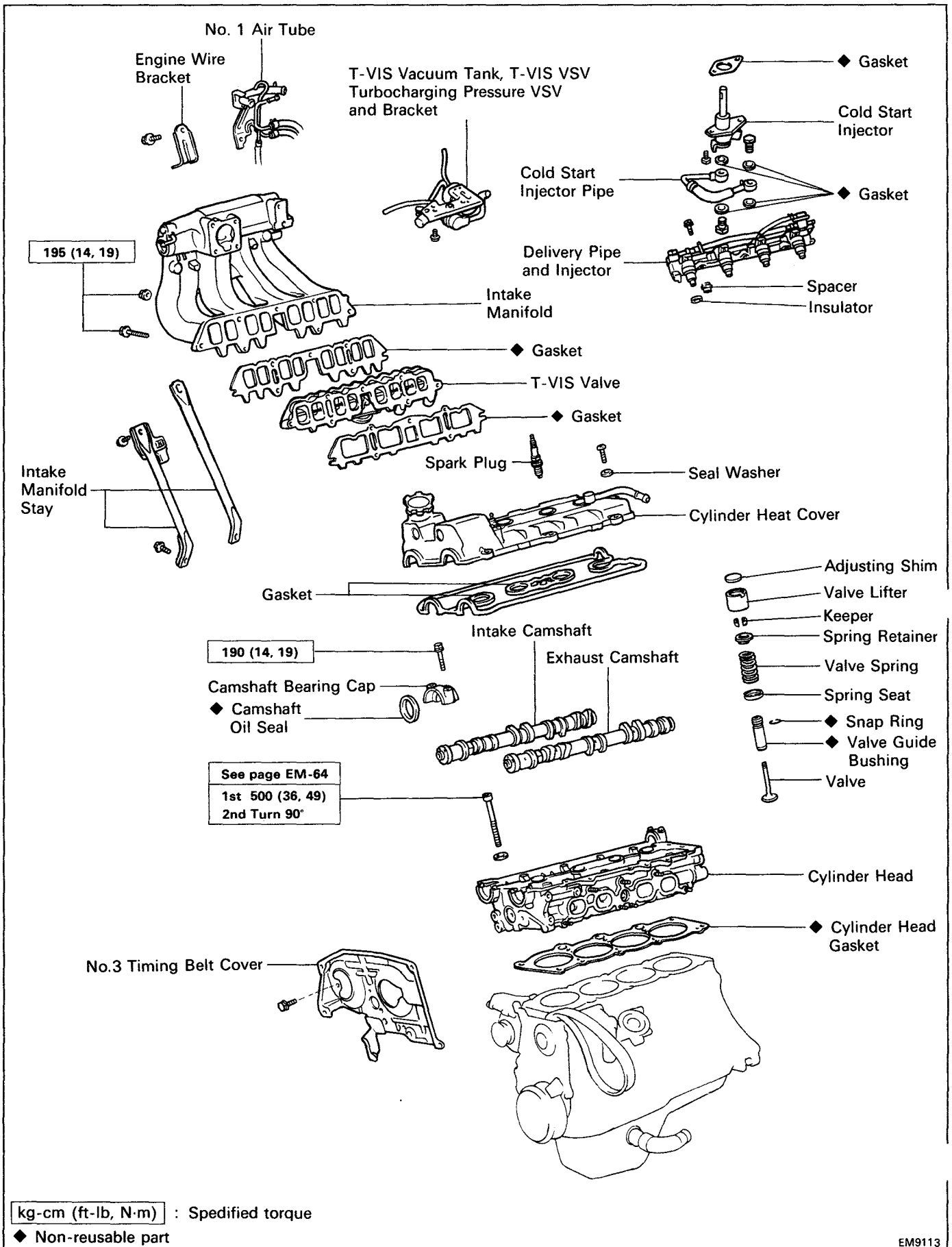

**REMOVAL OF CYLINDER HEAD (3S-GE)**

(See page EM-98)

**1. DRAIN ENGINE COOLANT****2. REMOVE ALTERNATOR**

- (a) Loosen the idler pulley bolt and adjusting bolt, and remove the drive belt.

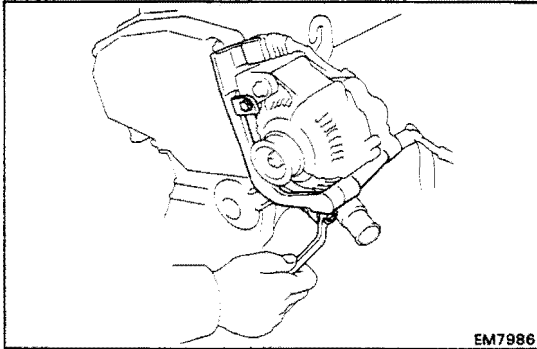

EM7986

- (b) Disconnect the alternator connector.

- (c) Remove the two bolts, disconnect the engine wire from the brackets.

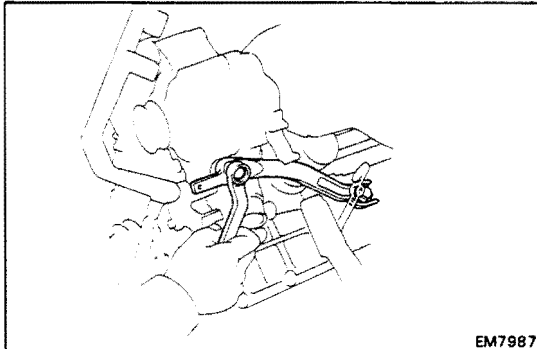

EM7987

- (d) Remove the two bolts and No.2 alternator bracket.

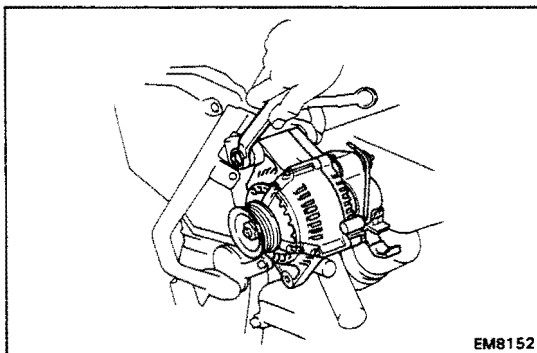

EM8152

- (e) Remove the nut, and disconnect the alternator wire.

- (f) Remove the two bolts and alternator.

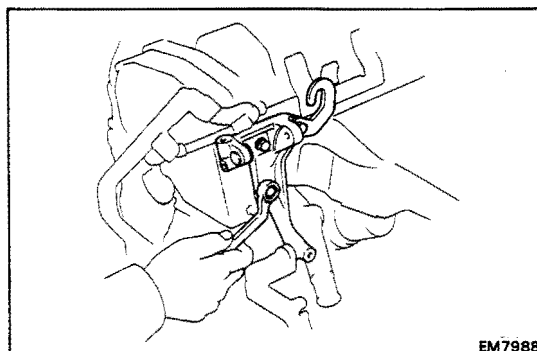

EM7988

**3. REMOVE RH FRONT ENGINE HANGER AND NO.1 ALTERNATOR BRACKET**

Remove the three bolts, engine hanger and alternator bracket.



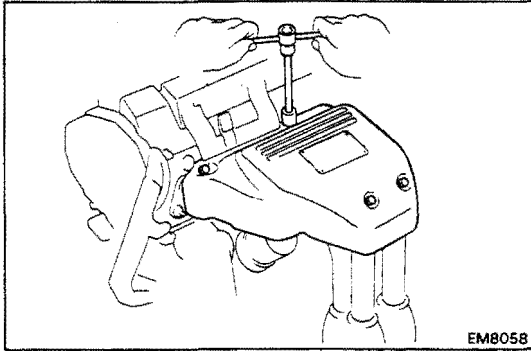

#### 4. REMOVE EXHAUST MANIFOLD

(a) Remove the five bolts and heat insulator.

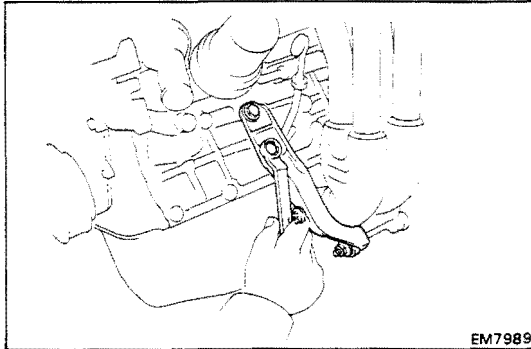

(b) Remove the three bolts, nut and RH manifold stay.

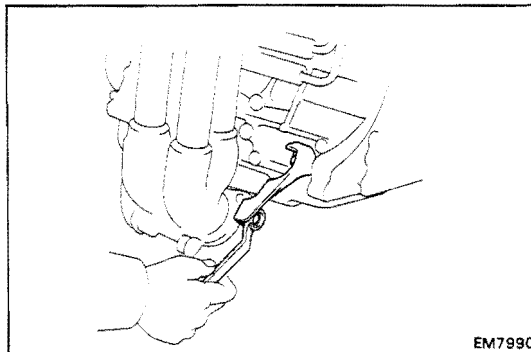

(c) Remove the two bolts and LH manifold stay.

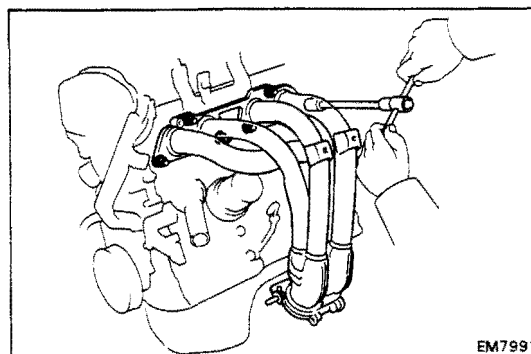

(d) Remove the six nuts, exhaust manifold and two gaskets.

#### 5. REMOVE WATER OUTLET

(a) Disconnect the following connectors:

- Water temperature sender gauge connector
- Water temperature sensor
- Cold start injector time switch connector

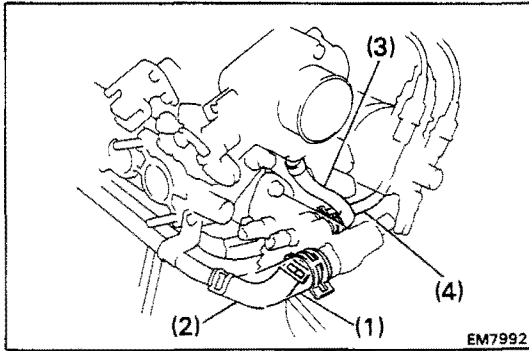

- (b) Disconnect the following hoses:
- (1) Upper radiator hose
  - (2) Water by-pass hose from water by-pass pipe
  - (3) Water by-pass pipe hose from ISC valve
  - (4) Heater water hose

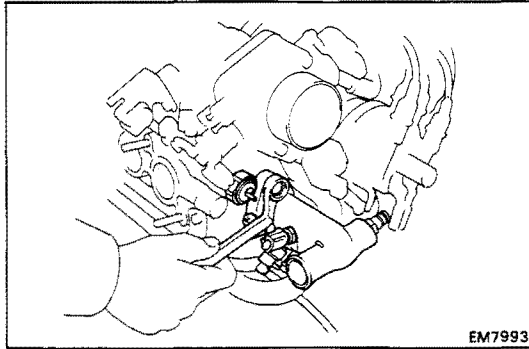

- (c) Remove the two bolts, water outlet and gasket.

## 6. REMOVE OIL PRESSURE SWITCH

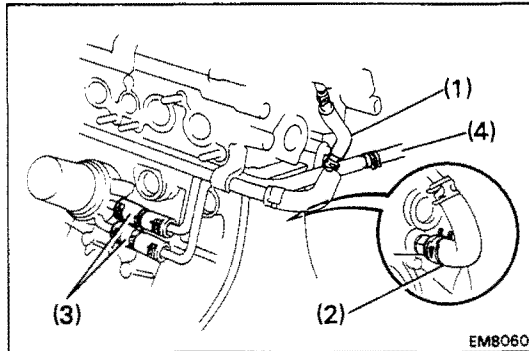

## 7. REMOVE WATER BY-PASS PIPE

- (a) Disconnect the following hoses:
- (1) Water by-pass hose from ISC valve
  - (2) Water by-pass hose from cylinder block
  - (3) Two water by-pass hoses from oil cooler
  - (4) Heater water hose

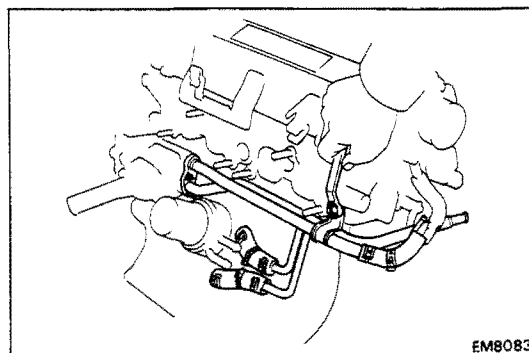

- (b) Remove the two bolts, two nuts, water by-pass pipe, gasket and O-ring.

## 8. REMOVE THROTTLE BODY (See steps 6 to 9 on page FI-166)

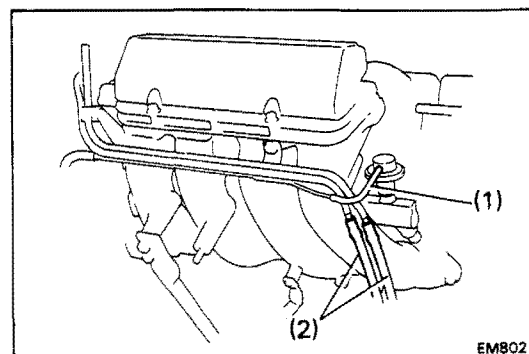

## 9. REMOVE AIR TUBE

- (a) Disconnect the following hoses:
- (1) Vacuum sensing hose from fuel pressure regulator
  - (2) Two PS vacuum hoses

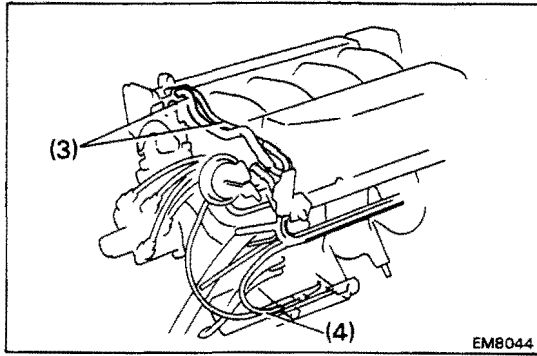

- (3) Two vacuum hoses from air intake chamber
- (4) Vacuum hose from vacuum pipe (from fuel pressure VSV)

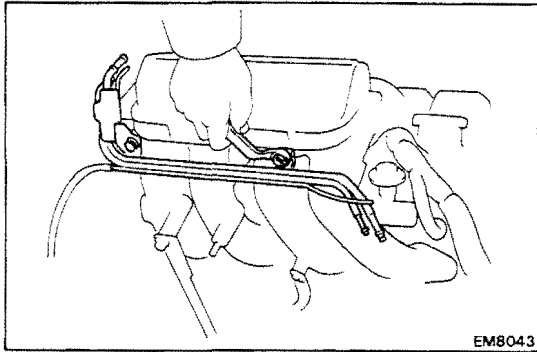

- (b) Remove the two bolts and air tube.

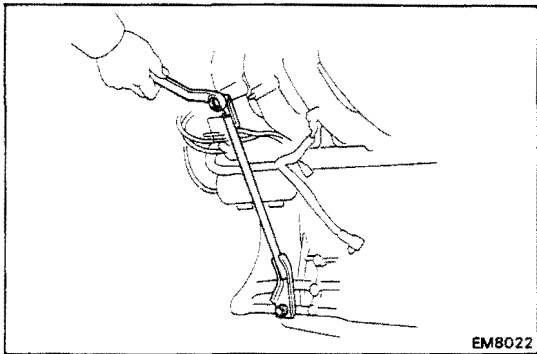

#### 10. REMOVE INTAKE MANIFOLD STAY

Remove the two bolts and manifold stay

#### 11. REMOVE ACIS VACUUM TANK, ACIS VSV, FUEL PRESSURE VSV AND BRACKET

- (a) Disconnect the following connectors:
  - Fuel pressure VSV connector
  - ACIS VSV connector

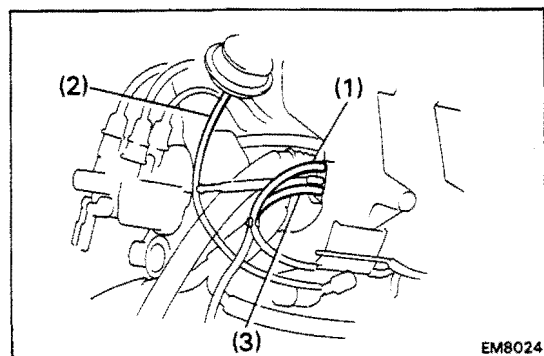

- (b) Disconnect the following hoses:
  - (1) Vacuum hose (from fuel pressure VSV) from intake manifold
  - (2) Vacuum hose (from ACIS VSV) from ACIS actuator
  - (3) Vacuum hose (from vacuum tank) from intake manifold

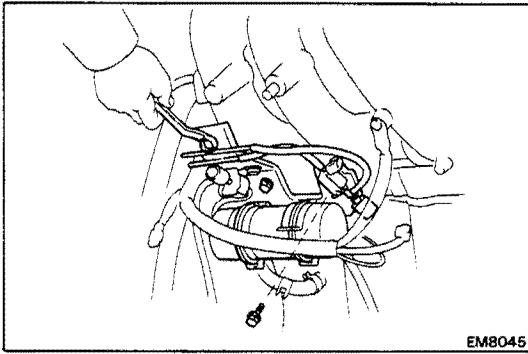

- (c) Remove the three bolts, the ACIS vacuum tank, ACIS VSV, fuel pressure VSV and bracket assembly.

**12. REMOVE COLD START INJECTOR**  
(See steps 2 to 4 on pages FI-121 and 122)

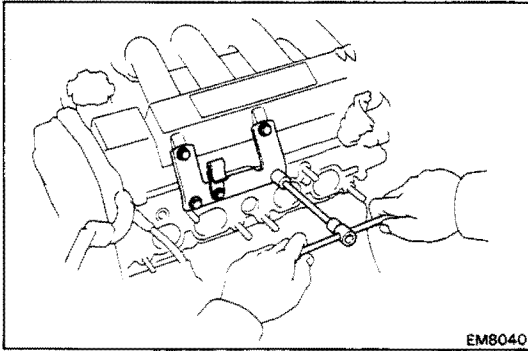

**13. REMOVE AIR INTAKE CHAMBER**

- (a) Remove the four bolts and No.2 chamber stay.

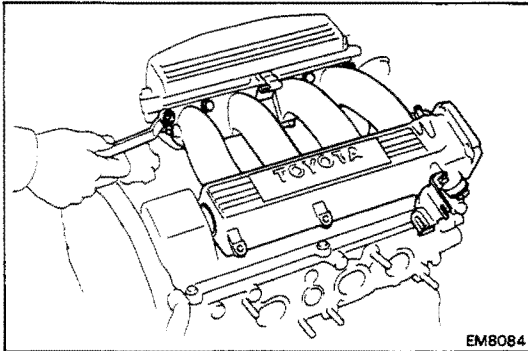

- (b) Remove the six bolts, two nuts, air intake chamber and gasket.

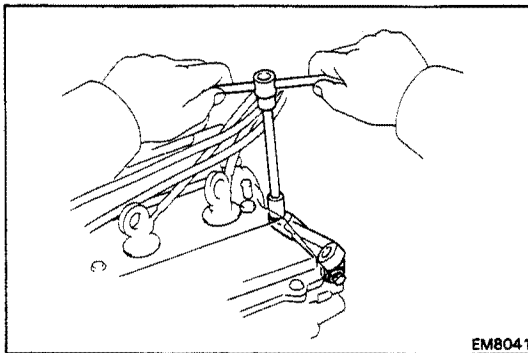

- (c) Remove the two bolts and No.1 chamber stay.

**14. REMOVE DISTRIBUTOR**

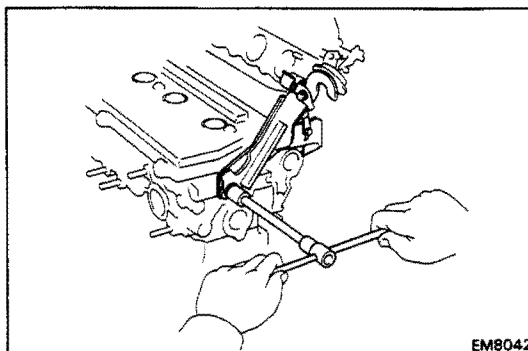

**15. REMOVE LH ENGINE HANGER**

- Remove the two bolts and engine hanger.

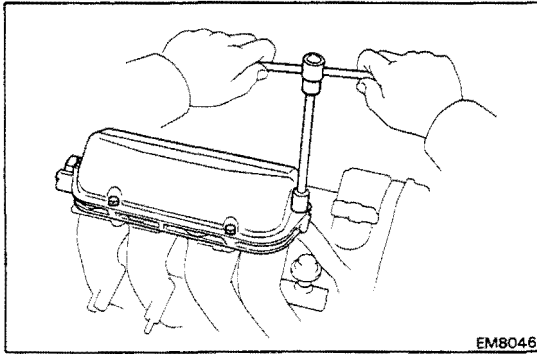
**16. REMOVE ACIS VALVE**

Remove the two bolts and two nuts, ACIS valve and gasket.

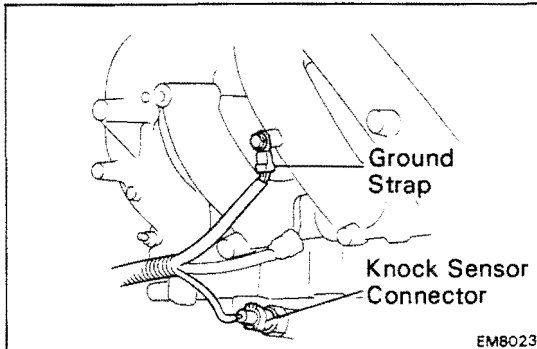
**17. REMOVE INTAKE MANIFOLD**

- (a) Remove the bolt, and disconnect the ground strap.
- (b) Disconnect the knock sensor connector.

- (c) Remove the four bolts, three nuts, intake manifold and gasket.

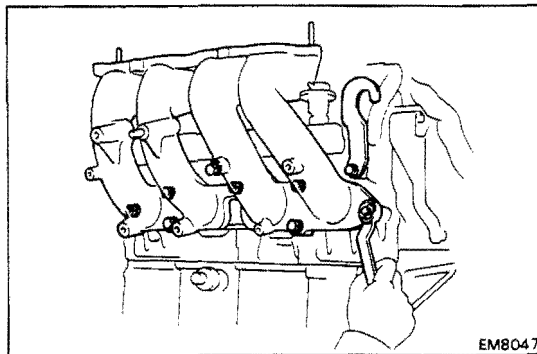
**18. REMOVE RH REAR ENGINE HANGER**

Remove the bolt and engine hanger.

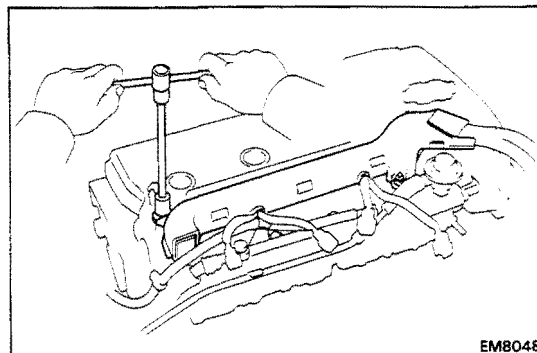
**19. DISCONNECT ENGINE WIRE FROM CYLINDER HEAD COVER**

- (a) Disconnect the four injector connectors
- (b) Remove the two bolts, and disconnect the engine wire from cylinder head cover

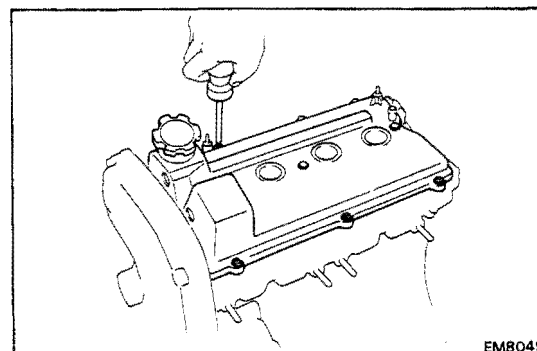
**20. REMOVE DELIVERY PIPE AND INJECTORS**  
(See step 18 on page FI-143)**21. REMOVE CYLINDER HEAD COVER**

Remove the ten screws, seal washers, head cover and two gaskets.

22. REMOVE CAMSHAFT TIMING PULLEYS  
(See steps 10 to 13 on pages EM-46 and 47)
23. REMOVE NO.1 IDLER PULLEY  
(See step 18 on page EM-50)
24. REMOVE NO.3 TIMING BELT COVER  
(See step 29 on page EM-114)
25. REMOVE INTAKE AND EXHAUST CAMSHAFTS  
(See step 30 on page EM-114)
26. REMOVE CYLINDER HEAD  
(See step 31 on page EM-115)

**REMOVAL OF CYLINDER HEAD (3S-GTE)**

(See pages EM-99 and 100)

1. DRAIN ENGINE COOLANT
2. REMOVE INTERCOOLER  
(See steps 4 to 6 on page TC-9)

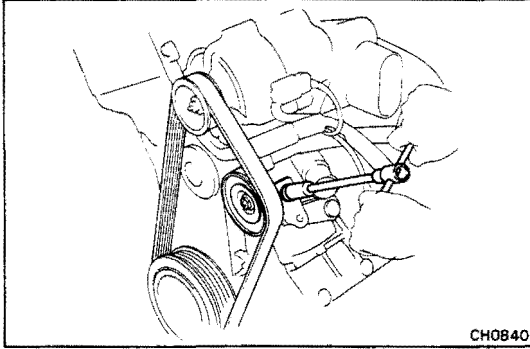
**3. REMOVE ALTERNATOR**

- (a) Loosen the idler pulley bolt and adjusting bolt, and remove the drive belt.

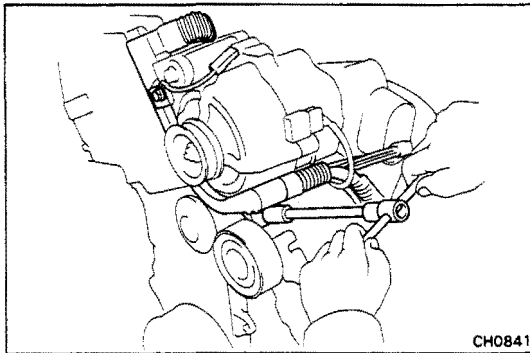

- (b) Disconnect the alternator connector from the lead wire.
- (c) Remove the two bolts, disconnect the engine wire from the brackets.

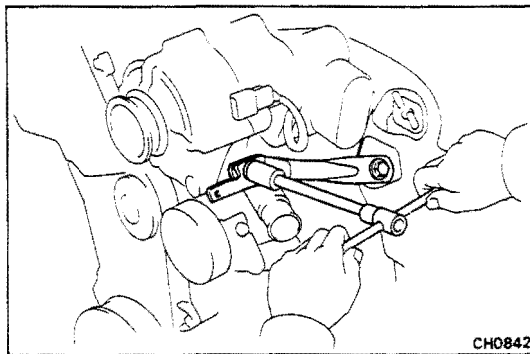

- (d) Remove the two bolts and No.2 alternator bracket.

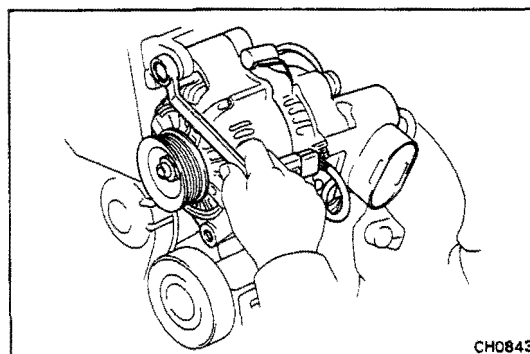

- (e) Remove the nut, and disconnect the alternator wire.
- (f) Remove the two bolts and alternator.

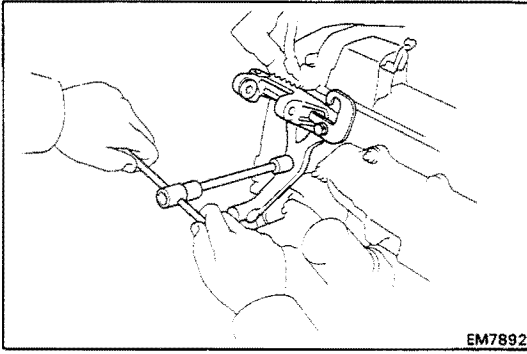

**4. REMOVE RH FRONT ENGINE HANGER AND NO.1 ALTERNATOR BRACKET**

Remove the three bolts, engine hanger and alternator bracket.

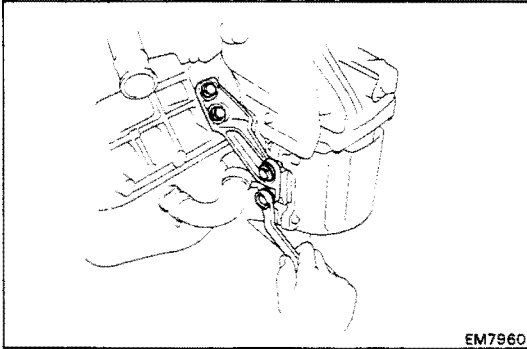

**5. REMOVE CATALYTIC CONVERTER**

(a) Remove the four bolts and RH converter stay.

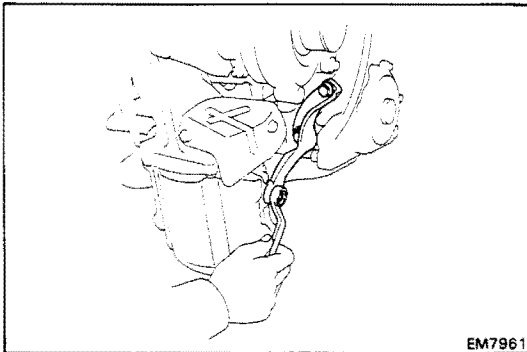

(b) Remove the three bolts and LH converter stay.

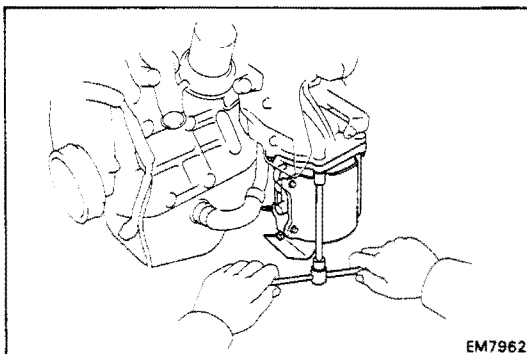

(c) Remove the three bolts, two nuts, catalytic converter. Remove the gasket, retainer and cushion.

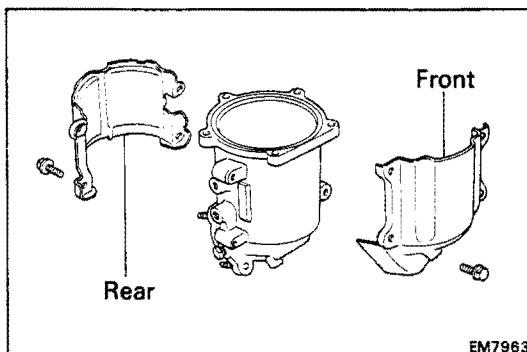

(d) Remove the five bolts and front heat insulator.

(e) Remove the four bolts and rear heat insulator.



6. REMOVE TURBOCHARGER  
(See steps 7 to 12 on pages TC-9 to 11)
7. REMOVE THROTTLE BODY  
(See steps 5 to 10 on pages FI-170 and 171)
8. REMOVE COLD START INJECTOR  
(See steps 2 to 4 on pages FI-124 and 125)

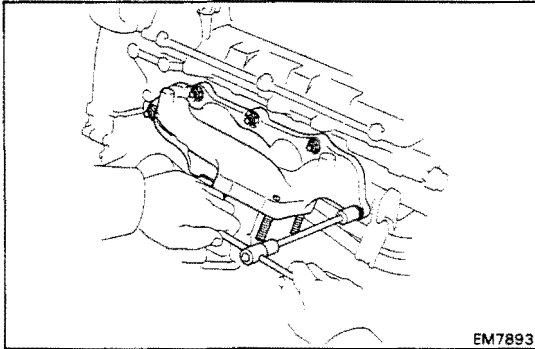

9. REMOVE EXHAUST MANIFOLD

- (a) Remove the seven nuts, exhaust manifold and gasket.

- (b) Remove the bolt, nut and heat insulator.

10. REMOVE DISTRIBUTOR

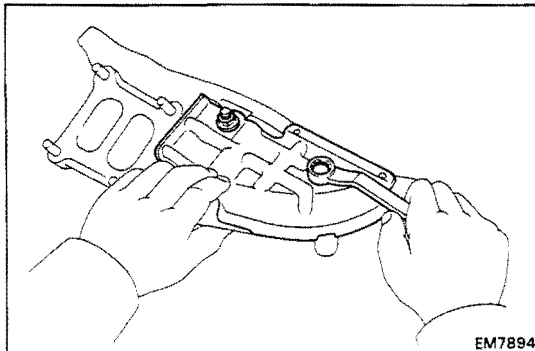

11. REMOVE NO.2 AIR TUBE

- (a) Disconnect the air hose from the No.1 air tube.
- (b) Remove the bolt and No.1 air tube.

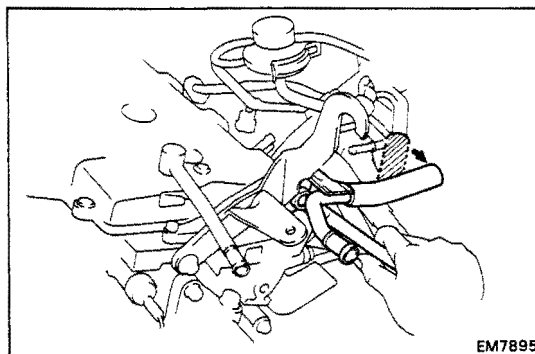

12. REMOVE LH ENGINE HANGER

- Remove the two bolts and engine hanger.

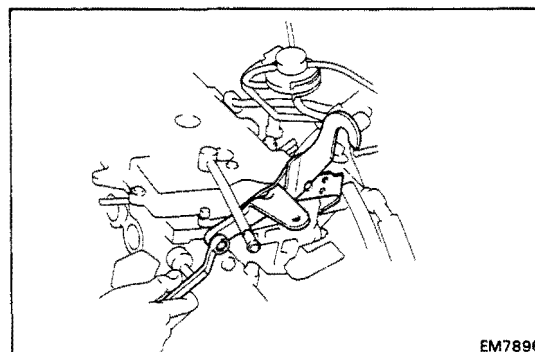

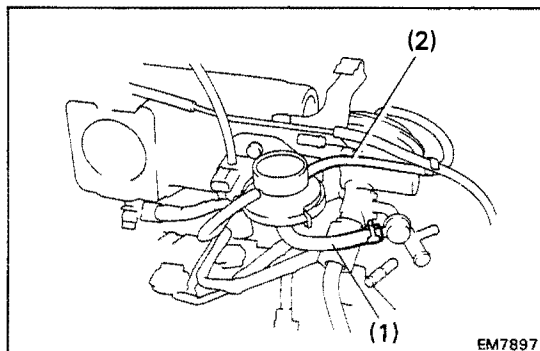
**13. REMOVE EGR VACUUM MODULATOR AND VSV**

- (a) Disconnect the EGR VSV connector.
- (b) Disconnect the following vacuum hoses:
  - (1) Vacuum hose from EGR valve
  - (2) Vacuum hose from EGR vacuum modulator

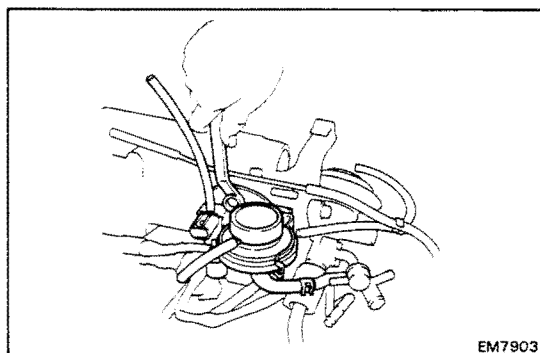

- (c) Remove the bolt, vacuum modulator and VSV assembly.

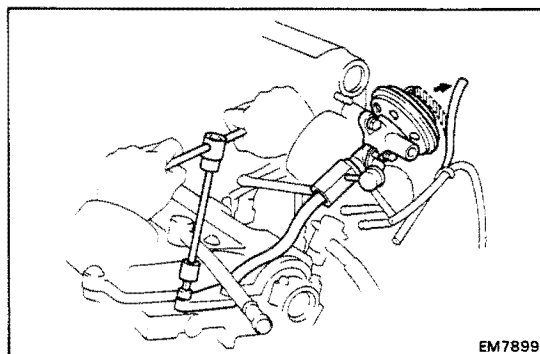
**14. REMOVE EGR VALVE AND PIPE**

- (a) Disconnect the vacuum hose from the EGR valve.
- (b) Remove the four bolts, the EGR valve, pipe assembly and two gaskets.

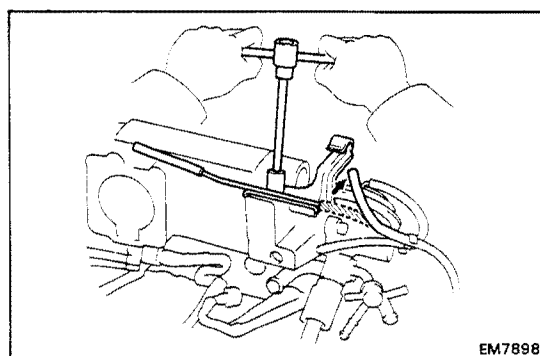
**15. REMOVE VACUUM PIPE**

- (a) Disconnect the vacuum hose from the vacuum pipe.
- (b) Remove the bolt and vacuum pipe.

**16. REMOVE WATER OUTLET**

- (a) Disconnect the following connectors:
  - Water temperature sender gauge connector
  - Water temperature sensor
  - Cold start injector time switch connector

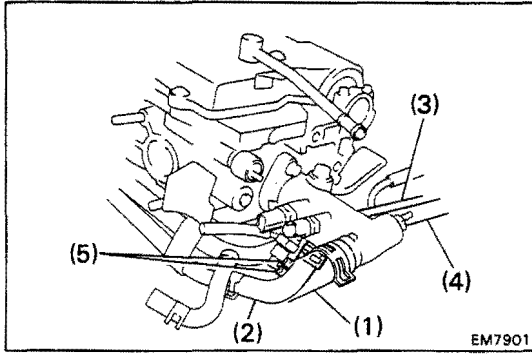

- (b) Disconnect the following hoses:
- (1) Upper radiator hose
  - (2) Water by-pass hose from water by-pass pipe
  - (3) Water by-pass pipe hose from ISC valve
  - (4) Heater water hose
  - (5) Two EVAP VSV vacuum hoses

- (c) Remove the two bolts, water outlet and gasket.

#### 17. REMOVE OIL PRESSURE SWITCH

#### 18. REMOVE OIL COOLER

(See steps 3 to 5 on pages LU-19 and 20)

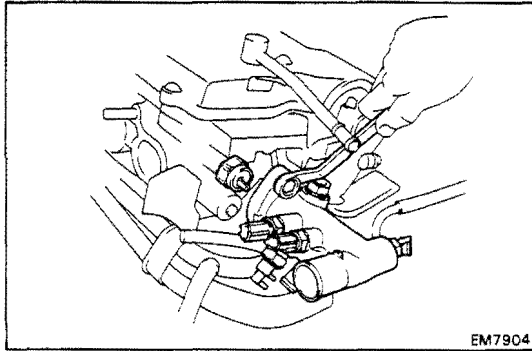

#### 19. REMOVE WATER BY-PASS PIPE

- (a) Disconnect the following hoses:

- (1) Water by-pass hose from cylinder block
- (2) Water by-pass hoses from No.1 air tube
- (3) Vacuum hose from turbocharging pressure VSV
- (4) Heater water hose

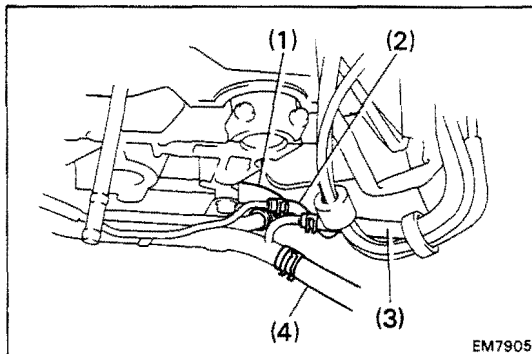

- (b) Remove the two bolts, two nuts, water by-pass pipe, gasket and O-ring.

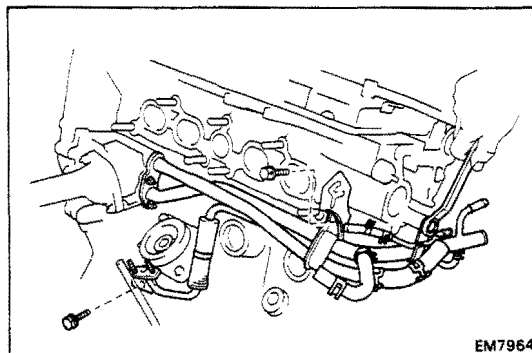

#### 20. REMOVE INTAKE MANIFOLD STAYS

Remove the two bolts and manifold stay. Remove the two manifold stays

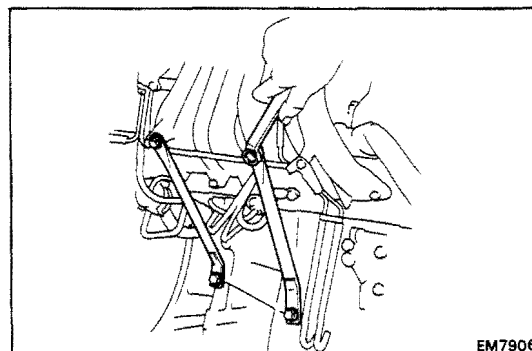

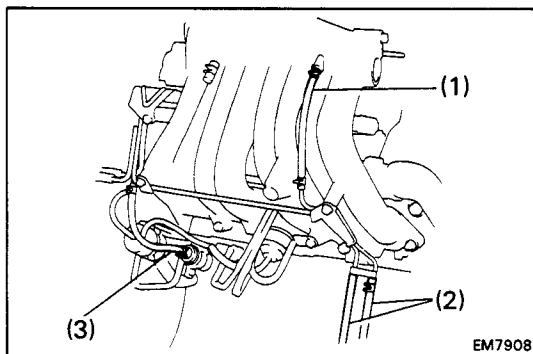
**21. REMOVE NO.1 AIR TUBE**

- (a) Disconnect the following hoses:
- (1) Vacuum hose from intake manifold
  - (2) Two PS vacuum hoses
  - (3) Vacuum hose from turbocharging pressure VSV
- (b) Remove the three bolts and air tube.

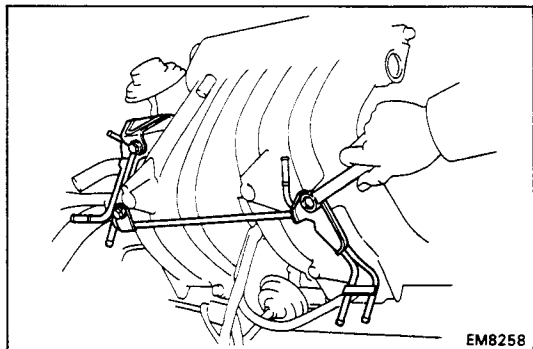
**22. REMOVE T-VIS VACUUM TANK, T-VIS VSV, TURBOCHARGING PRESSURE VSV AND BRACKET**

- (a) Disconnect the following connectors:
- T-VIS VSV connector
  - Turbocharging pressure VSV connector

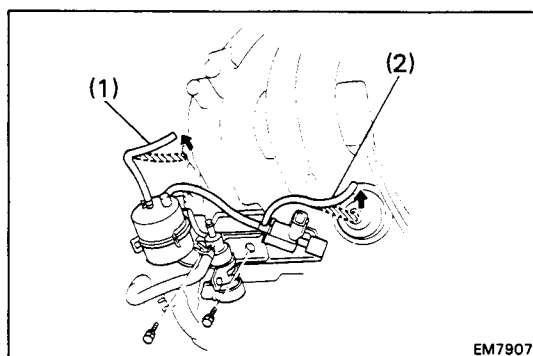

- (b) Disconnect the following hoses:
- (1) Vacuum hose (from T-VIS VSV) from T-VIS actuator
  - (2) Vacuum hose (from T-VIS vacuum tank) from intake manifold
- (c) Remove the two bolts, the T-VIS vacuum tank, T-VIS VSV, turbocharging pressure VSV and bracket assembly.

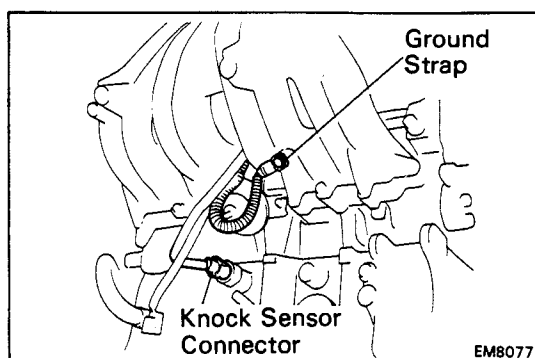
**23. REMOVE INTAKE MANIFOLD AND T-VIS VALVE**

- (a) Remove the bolt, and disconnect the ground strap.
- (b) Disconnect the knock sensor connector.

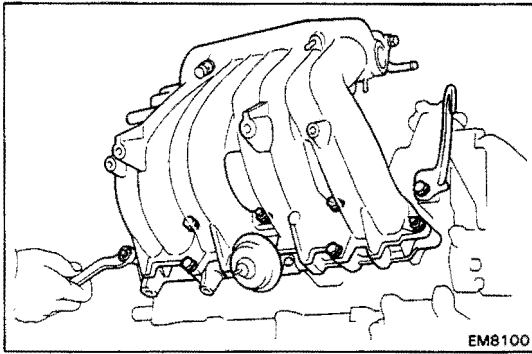

- (c) Remove the four bolts, three nuts, intake manifold, T-VIS VSV and two gaskets.

#### 24. REMOVE RH REAR ENGINE HANGER

Remove the bolt and engine hanger.

#### 25. REMOVE DELIVERY PIPE AND INJECTORS (See steps 4 to 7 on page FI-150)

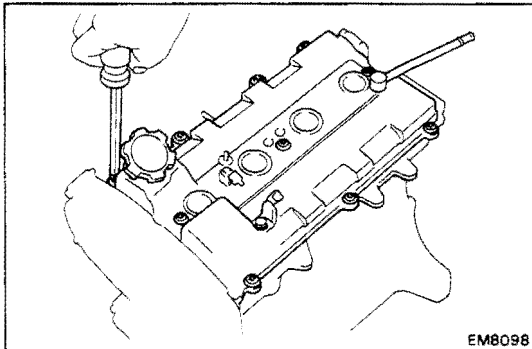

#### 26. REMOVE CYLINDER HEAD COVER

Remove the ten screws, seal washers, head cover and two gaskets.

#### 27. REMOVE CAMSHAFT TIMING PULLEYS (See steps 10 to 13 on pages EM-46 and 47)

#### 28. REMOVE NO.1 IDLER PULLEY (See step 18 on page EM-50)

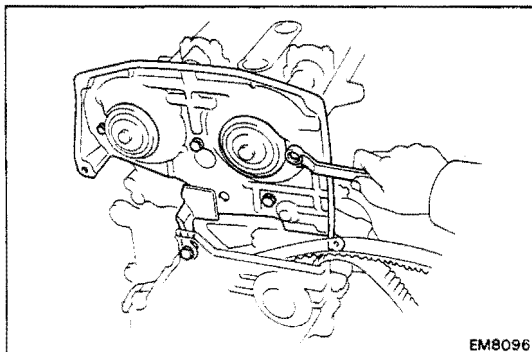

#### 29. REMOVE NO.3 TIMING BELT COVER

Remove the five bolts and timing belt cover.

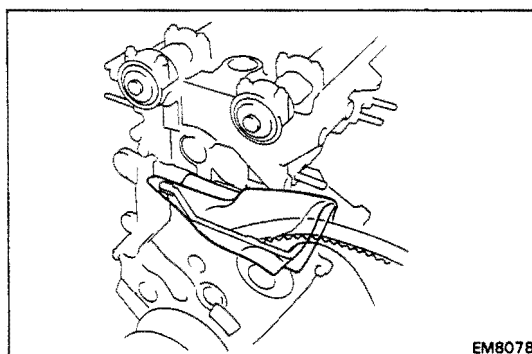

#### HINT:

- Support the timing belt, so that the meshing of the crankshaft timing pulley and timing belt does not shift.
- Be careful not to drop anything inside the timing belt cover.
- Do not allow the timing belt to come into contact with oil, water or dust.

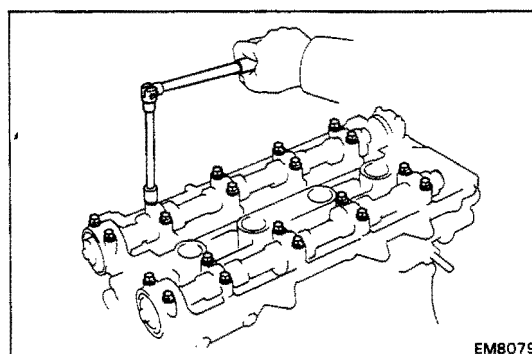

#### 30. REMOVE CAMSHAFTS

Uniformly loosen and remove the ten bearing cap bolts in several passes in the sequence shown, and Remove the five bearing caps, oil seal and camshaft. Remove the intake and exhaust camshafts.

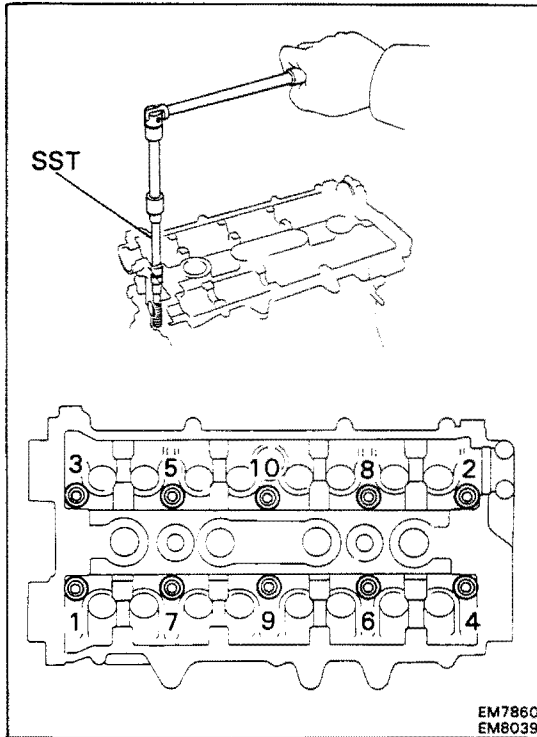

### 31. REMOVE CYLINDER HEAD

- (a) Using SST, uniformly loosen and remove the ten cylinder head bolts in several passes in the sequence shown.

SST 09043-38100

HINT: Cylinder head warpage or cracking could result from removing in the incorrect order.

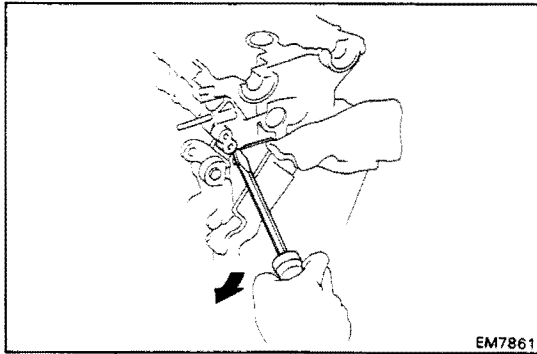

- (b) Lift the cylinder head from the dowels on the cylinder block, and place the cylinder head on wooden blocks on a bench.

HINT: If the cylinder head is difficult to lift off, pry between the cylinder head and cylinder block with a screwdriver.

**NOTICE:** Be careful not to damage the contact surfaces of the cylinder head and cylinder block.

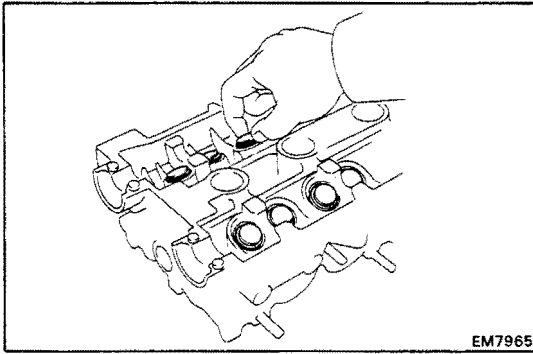

EM7965

## DISASSEMBLY OF CYLINDER HEAD

3S-GE (See page EM-98)

3S-GTE (See pages EM-99 and 100)

### 1. REMOVE VALVE LIFTERS AND SHIMS

**HINT:** Arrange the valve lifters and shims in correct order.

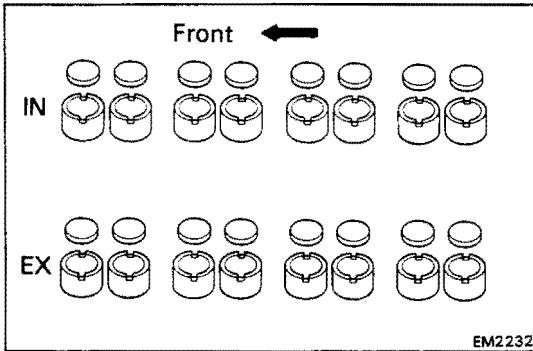

EM2232

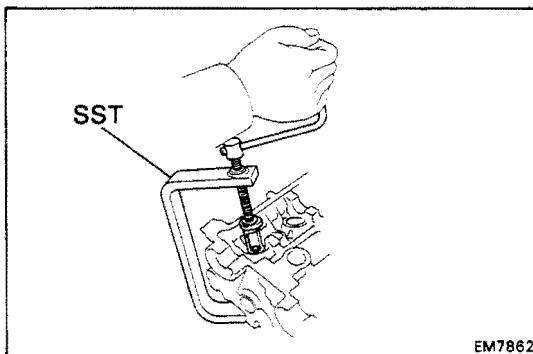

EM7862

### 2. REMOVE VALVES

(a) Using SST, compress the valve spring and remove the two keepers.

SST 09202-70010

(b) Remove the spring retainer, valve spring, valve and spring seat.

**HINT:** Arrange the valves, valve springs, spring seats and spring retainers in correct order.

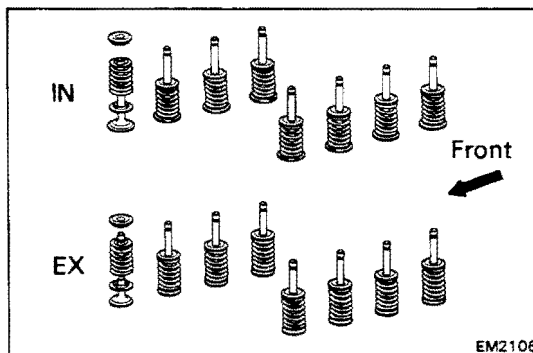

EM2106

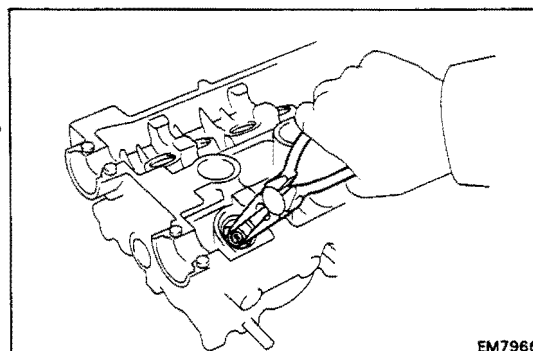

EM7966

(c) Using needle-nose pliers, remove the oil seal.

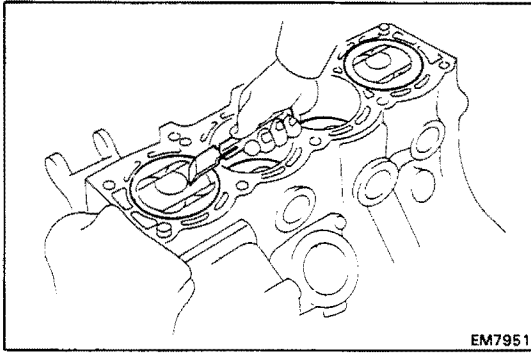

EM7951

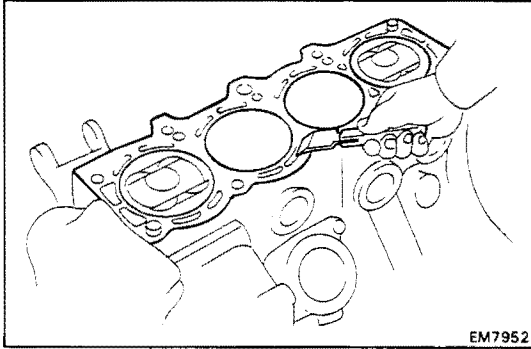

EM7952

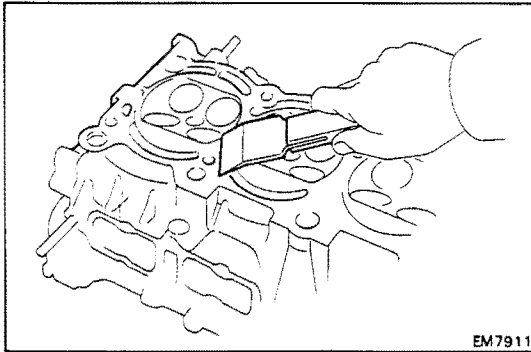

EM7911

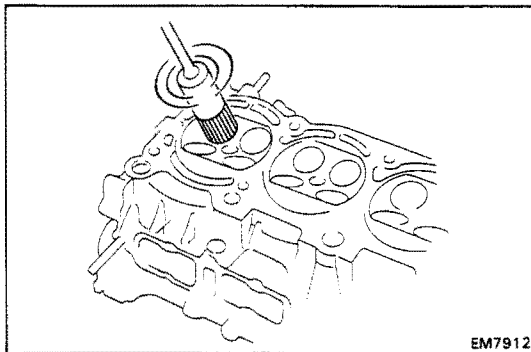

EM7912

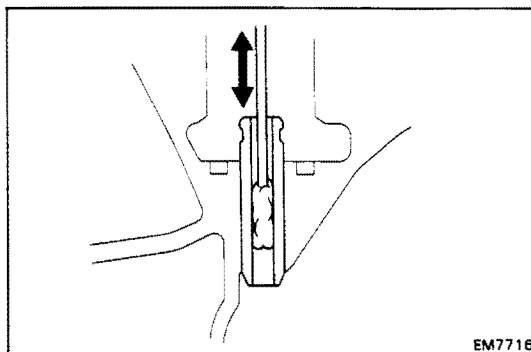

EM7716

## INSPECTION, CLEANING AND REPAIR OF CYLINDER HEAD COMPONENTS

### 1. CLEAN TOP SURFACES OF PISTONS AND CYLINDER BLOCK

(a) Turn the crankshaft, and bring each piston to top dead center (TDC). Using a gasket scraper, remove all the carbon from the piston top surface.

(b) Using a gasket scraper, remove all the gasket material from the top surface of the cylinder block.

(c) Using compressed air, blow carbon and oil from the bolt holes.

**CAUTION:** Protect your eyes when using high-compressed air.

### 2. REMOVE GASKET MATERIAL

#### A. Remove gasket material

Using a gasket scraper, remove all the gasket material from the cylinder block surface.

**NOTICE:** Be careful not to scratch the cylinder block contact surface.

#### B. Clean combustion chambers

Using a wire brush, remove all the carbon from the combustion chambers.

**NOTICE:** Be careful not to scratch the cylinder block contact surface.

#### C. Clean valve guide bushings

Using a valve guide bushing brush and solvent, clean all the guide bushings.



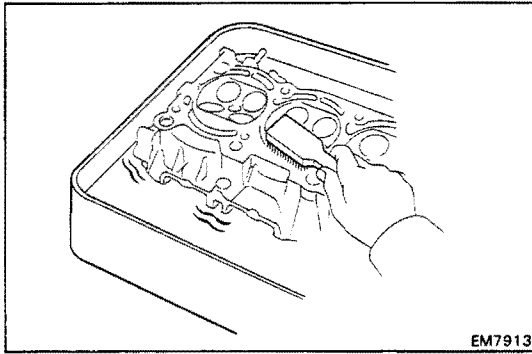

EM7913

**D. Clean cylinder head**

Using a soft brush and solvent, thoroughly clean the cylinder head.

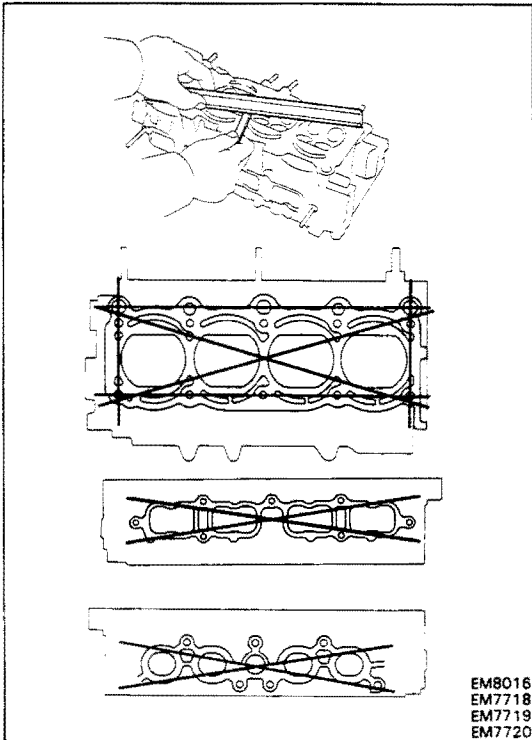
EM8016  
EM7718  
EM7719  
EM7720**3. INSPECT CYLINDER HEAD****A. Inspect for flatness**

Using precision straight edge and feeler gauge, measure the surfaces contacting the cylinder block, manifolds and T-VIS valve (3S-GTE) for warpage.

**Maximum warpage:**

Cylinder block side	0.20 mm (0.0079 in.)
Intake manifold side	0.20 mm (0.0079 in.)
Exhaust manifold side	0.30 mm (0.0118 in.)

If warpage is greater than maximum, replace the cylinder head.

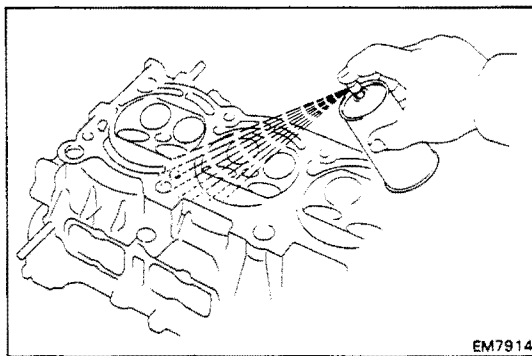

EM7914

**B. Inspect for cracks**

Using a dye penetrant, check the combustion chamber, intake ports, exhaust ports and cylinder block surface for cracks.

If cracked, replace the cylinder head.

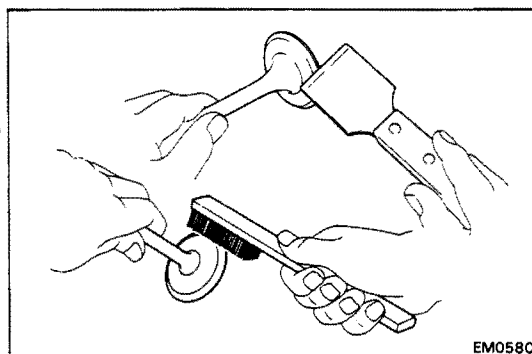

EM0580

**4. CLEAN VALVES**

- (a) Using a gasket scraper, chip off any carbon from the valve head.
- (b) Using a wire brush, thoroughly clean the valve.

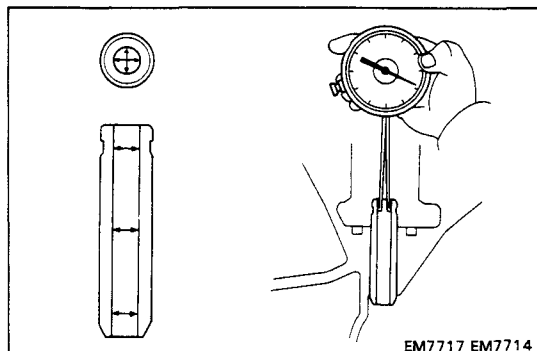
**5. INSPECT VALVE STEMS AND GUIDE BUSHINGS**

- (a) Using a caliper gauge, measure the inside diameter of the guide bushing.

**Bushing inside diameter:**

**6.000 – 6.018 mm (0.2362 – 0.2369 in.)**

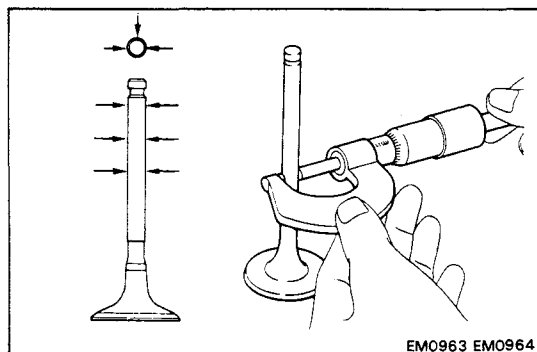

- (b) Using a micrometer, measure the diameter of the valve stem.

**Valve stem diameter:**

**Intake 5.960 – 5.975 mm  
(0.2346 – 0.2352 in.)**

**Exhaust 5.955 – 5.970 mm  
(0.2344 – 0.2350 in.)**

- (c) Subtract the valve stem diameter measurement from the guide bushing inside diameter measurement.

**Standard oil clearance:**

**Intake 0.025 – 0.058 mm  
(0.0010 – 0.0023 in.)**

**Exhaust 0.030 – 0.063 mm  
(0.0012 – 0.0025 in.)**

**Maximum oil clearance:**

**Intake 0.08 mm (0.0031 in.)**

**Exhaust 0.10 mm (0.0039 in.)**

If the clearance is greater than maximum, replace the valve and guide bushing.

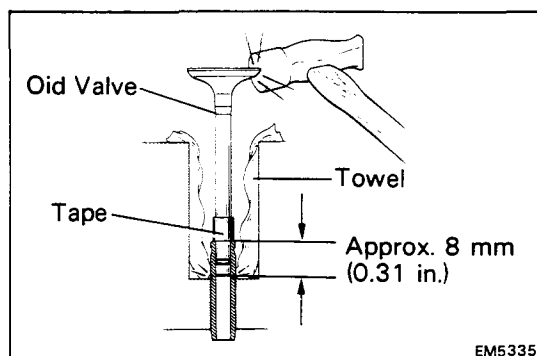
**6. IF NECESSARY, REPLACE VALVE GUIDE BUSHINGS**

- (a) (w/ Snap Ring)

Insert an old valve wrapped with tape into the valve guide bushing, and break off the valve guide bushing by hitting it with a hammer. Remove the snap ring.

**HINT:** Wrap the tape approx. 8 mm (0.31 in.) from the valve stem end.

**NOTICE:** Be careful not damage to the valve lifter hole.

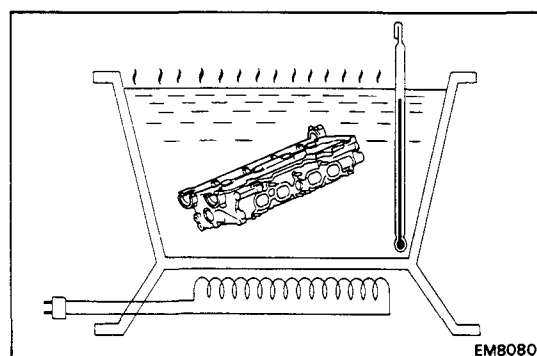

- (b) Gradually heat the cylinder head to 80 – 100°C (176 – 212°F).

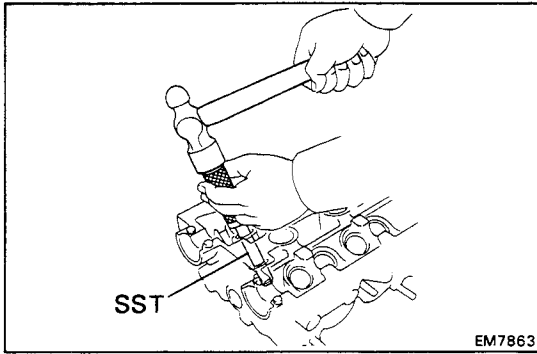

- (c) Using SST and a hammer, tap out the guide bushing.  
SST 09201-70010

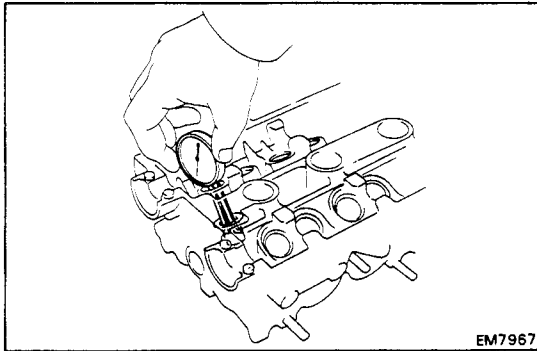

- (d) Using a caliper gauge, measure the bushing bore diameter of the cylinder head.

Both intake and exhaust

Bushing bore diameter mm (in.)	Bushing size
10.988 – 11.006 (0.4326 – 0.4333)	Use STD
11.038 – 11.056 (0.4346 – 0.4353)	Use O/S 0.05

- (e) Select a new guide bushing (STD size or O/S 0.05).  
If the bushing bore diameter of the cylinder head is greater than 11.006 mm (0.4333 in.), machine the bushing bore to the following dimension:

**11.038 – 11.056 mm (0.4346 – 0.4353 in.)**

- If the bushing bore diameter of the cylinder head is greater than 11.056 mm (0.4353 in.), replace the cylinder head.

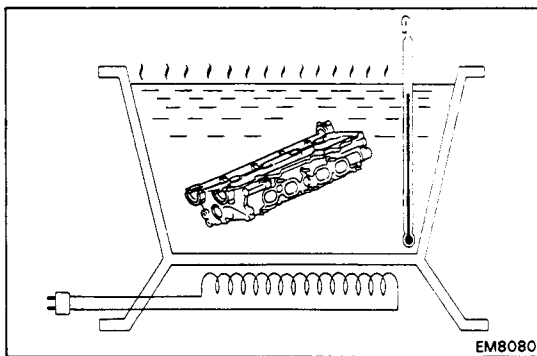

- (f) Gradually heat the cylinder head to 80 – 100°C (176 – 212°F).

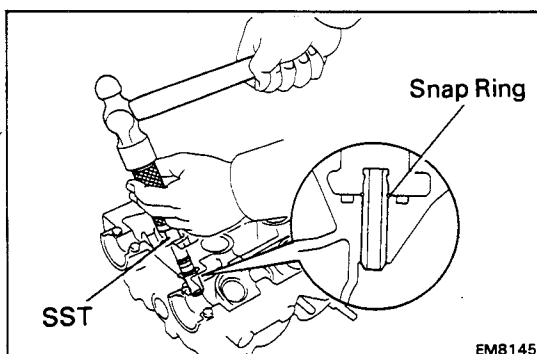

- (g) Using SST and a hammer, tap in a new guide bushing until the snap ring makes contact with the cylinder head.

SST 09201-70010

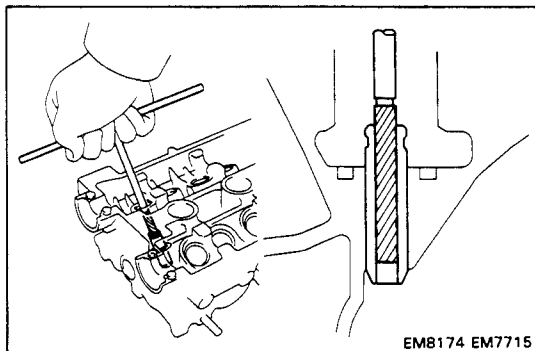

- (h) Using a sharp 6 mm reamer, ream the guide bushing to obtain the standard specified clearance (See page EM-119) between the guide bushing and valve stem.

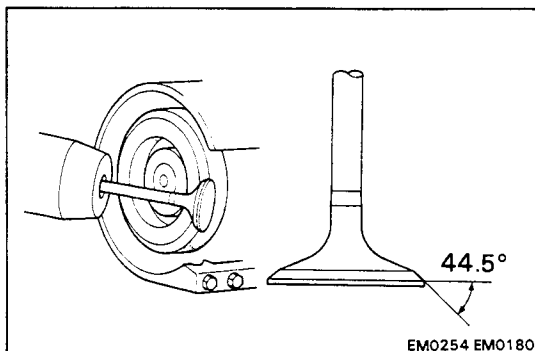

## 7. INSPECT AND GRIND VALVES

- (a) Grind the valve enough to remove pits and carbon.  
 (b) Check that the valve is ground to the correct valve face angle.

Valve face angle:  $44.5^\circ$

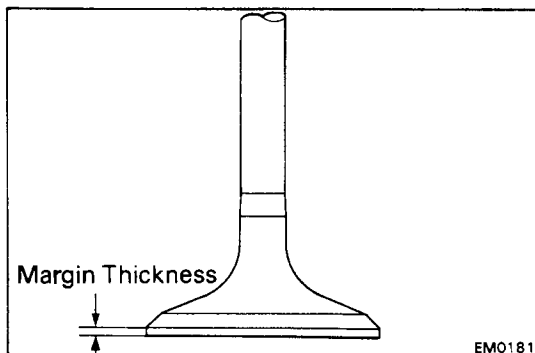

- (c) Check the valve head margin thickness.

**Standard margin thickness:** 0.8 – 1.2 mm  
 (0.031 – 0.047 in.)

**Minimum margin thickness:** 0.5 mm (0.020 in.)

If the margin thickness is less than minimum, replace the valve.

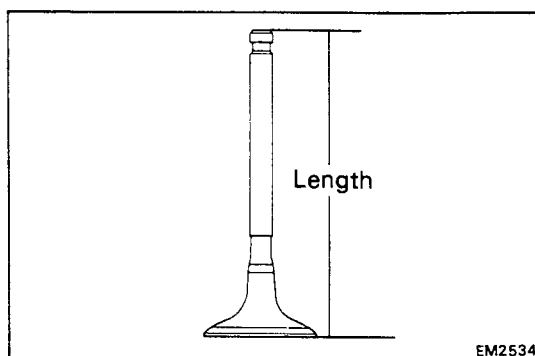

- (d) Check the valve overall length.

**Standard overall length:**

Intake 105.50 mm (4.1535 in.)

Exhaust 99.55 mm (3.9193 in.)

**Minimum overall length:**

Intake 104.80 mm (4.1260 in.)

Exhaust 98.85 mm (3.8917 in.)

If the overall length is less than minimum, replace the valve.

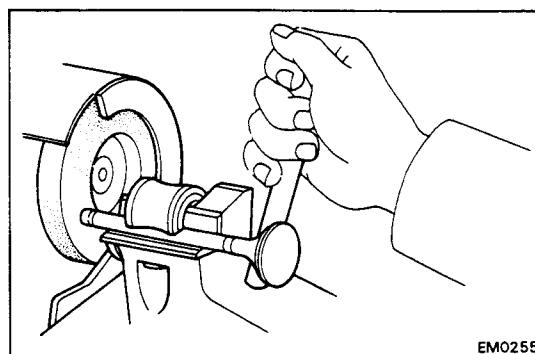

- (e) Check the surface of the valve stem tip for wear.

If the valve stem tip is worn, resurface the tip with a grinder or replace the valve.

**NOTICE:** Do not grind off more than the minimum.

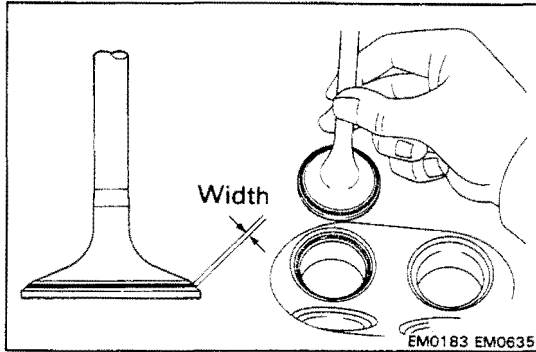
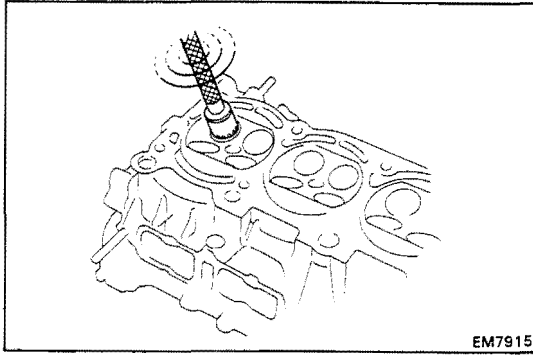

## 8. INSPECT AND CLEAN VALVE SEATS

- (a) Using a 45° carbide cutter, resurface the valve seats. Remove only enough metal to clean the seats.

- (b) Check the valve seating position.

Apply a thin coat of prussian blue (or white lead) to the valve face. Lightly press the valve against the seat. Do not rotate the valve.

- (c) Check the valve face and seat for the following:

- If blue appears 360° around the face, the valve is concentric. If not, replace the valve.
- If blue appears 360° around the valve seat, the guide and face are concentric. If not, resurface the seat.
- Check that the seat contact is in the middle of the valve face with the following width:

**1.0 – 1.4 mm (0.039 – 0.055 in.)**

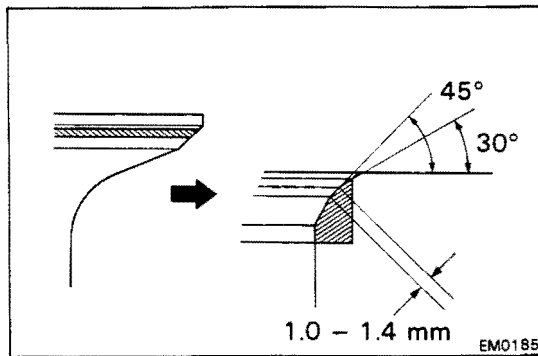

If not, correct the valve seats as follows:

- (1) If the seating is too high on the valve face, use 30° and 45° cutters to correct the seat.

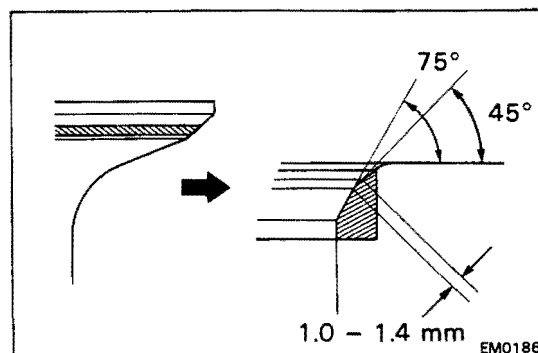

- (2) If the seating is too low on the valve face, use 75° and 45° cutters to correct the seat.

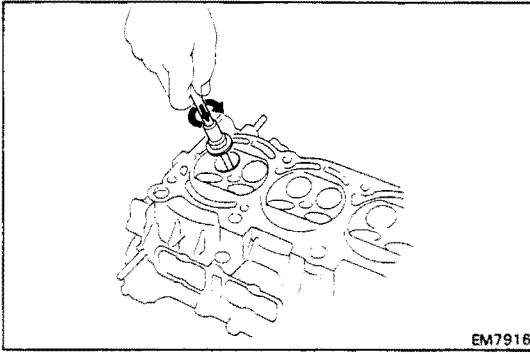

EM7916

- (d) Hand-lap the valve and valve seat with an abrasive compound.
- (e) After hand-lapping, clean the valve and valve seat.

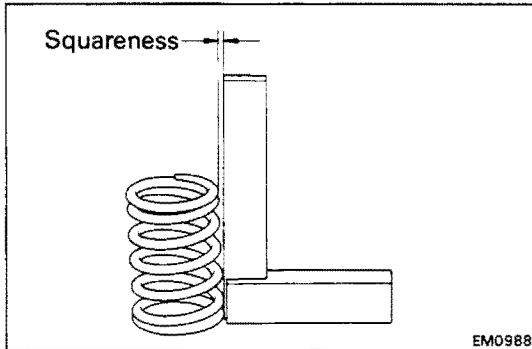

EM0988

## 9. INSPECT VALVE SPRINGS

- (a) Using a steel square, measure the squareness of the valve spring.

**Maximum squareness: 2.0 mm (0.079 in.)**

If squareness is greater than maximum, replace the valve spring.

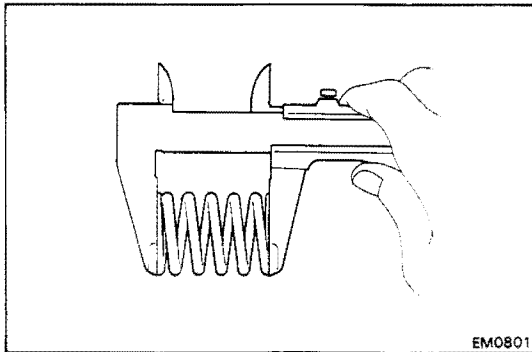

EM0801

- (b) Using vernier calipers, measure the free length of the valve spring.

**Free length: 44.43 mm (1.7492 in.)**

If the free length is not as specified, replace the valve spring.

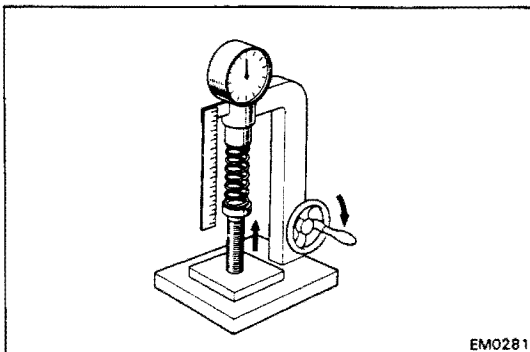

EM0281

- (c) Using a spring tester, measure the tension of the valve spring at the specified installed length.

**Installed tension:**

**20.5 – 24.1 kg (45.2 – 53.1 lb, 201 – 236 N)  
at 34.4 mm (1.354 in.)**

If the installed tension is not as specified, replace the valve spring.

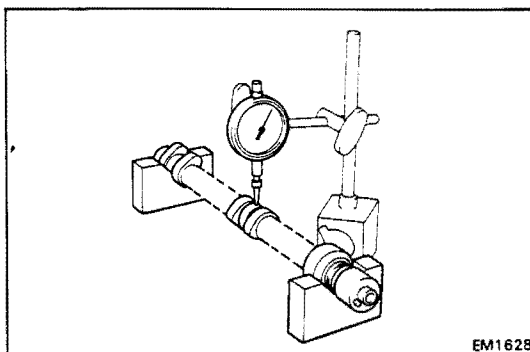

EM1628

## 10. INSPECT CAMSHAFTS AND BEARINGS

### A. Inspect camshaft for runout

- (a) Place the camshaft on V-blocks.
- (b) Using a dial indicator, measure the circle runout at the center journal.

**Maximum circle runout: 0.06 mm (0.0024 in.)**

If the circle runout is greater than maximum, replace the camshaft.

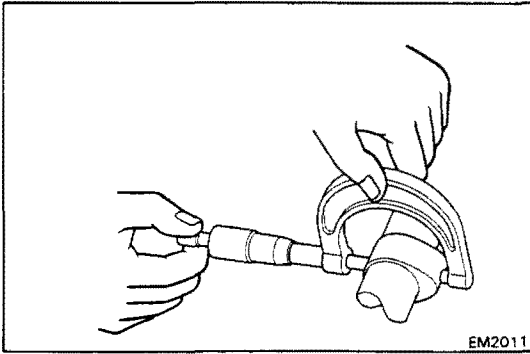
**B. Inspect cam lobes**

Using a micrometer, measure the cam lobe height.

**Standard cam lobe height:**

**3S-GE** 41.310 – 41.410 mm  
(1.6264 – 1.6303 in.)

**3S-GTE** 41.010 – 41.110 mm  
(1.6146 – 1.6185 in.)

**Minimum cam lobe height:**

**3S-GE** 41.20 mm (1.6220 in.)

**3S-GTE** 39.90 mm (1.5709 in.)

If the cam lobe height is greater than minimum, replace the camshaft.

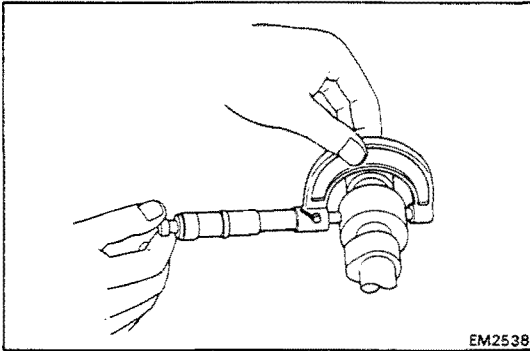
**C. Inspect camshaft journals**

Using a micrometer, measure the journal diameter.

**Journal diameter:** 26.959 – 26.975 mm  
(1.0614 – 1.0620 in.)

If the journal diameter is not as specified, check the oil clearance.

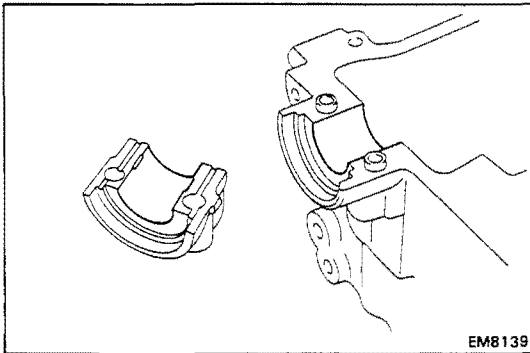
**D. Inspect camshaft bearings**

Check the bearings for flaking and scoring.

If the bearings are damaged, replace the bearing caps and cylinder head as a set.

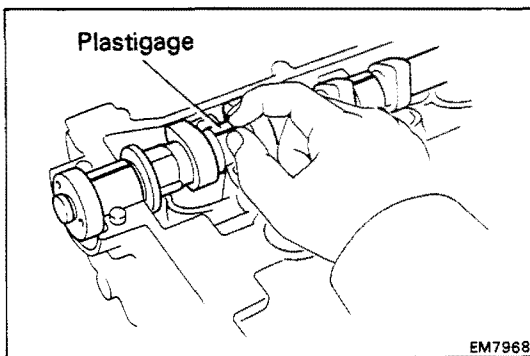
**E. Inspect camshaft journal oil clearance**

- (a) Clean the bearing caps and camshaft journals.
- (b) Place the camshafts on the cylinder head.
- (c) Lay a strip of Plastigage across each of the camshaft journals.

- (d) Install the bearing caps.  
(See step 4 on page EM-139)

**Torque:** 190 kg-cm (14 ft-lb, 19 N·m)

**NOTICE:** Do not turn the camshaft.

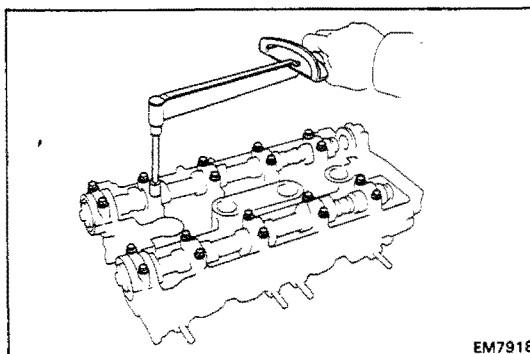

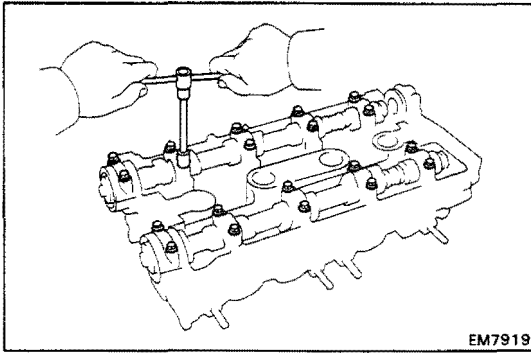

EM7919

(e) Remove the bearing caps.

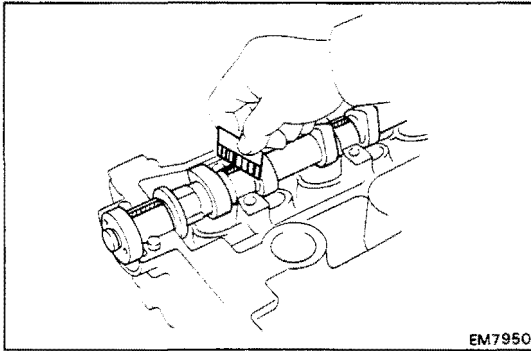

EM7950

(f) Measure the Plastigage at its widest point.

**Standard oil clearance:** 0.025 – 0.062 mm  
(0.0010 – 0.0024 in.)

**Maximum oil clearance:** 0.08 mm (0.0031 in.)

If the oil clearance is greater than maximum, replace the camshaft. If necessary, replace the bearing caps and cylinder head as a set.

(g) Completely remove the Plastigage.

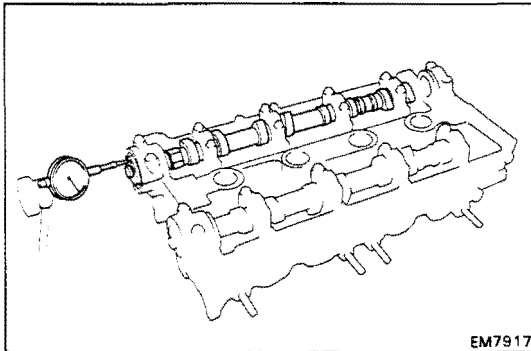

EM7917

#### F. Inspect camshaft thrust clearance

(a) Install the camshafts.

(See step 2 on page EM-139)

(b) Using a dial indicator, measure the thrust clearance while moving the camshaft back and forth.

**Standard thrust clearance:** 0.120 – 0.240 mm  
(0.0047 – 0.0094 in.)

**Maximum thrust clearance:** 0.30 mm (0.0118 in.)

If the thrust clearance is greater than maximum, replace the camshaft. If necessary, replace the bearing caps and cylinder head as a set.

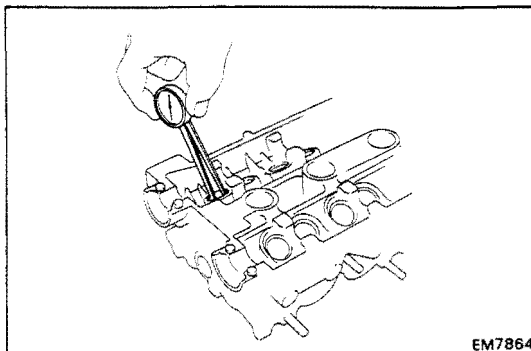

EM7864

#### 11. INSPECT VALVE LIFTERS AND LIFTER BORES

(a) Using a caliper gauge, measure the lifter bore diameter of the cylinder head.

**Lifter bore diameter:** 28.000 – 28.021 mm  
(1.1024 – 1.1032 in.)

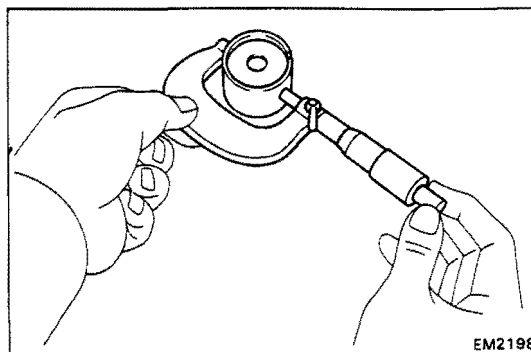

EM2198

(b) Using a micrometer, measure the lifter diameter.

**Lifter diameter:** 27.975 – 27.985 mm  
(1.1014 – 1.1018 in.)



- (c) Subtract the lifter diameter measurement from the lifter bore diameter measurement.

**Standard oil clearance: 0.015 – 0.046 mm  
(0.0005 – 0.0018 in.)**

**Maximum oil clearance: 0.07 mm (0.0028 in.)**

If the oil clearance is greater than maximum, replace the lifter. If necessary, replace the cylinder head.

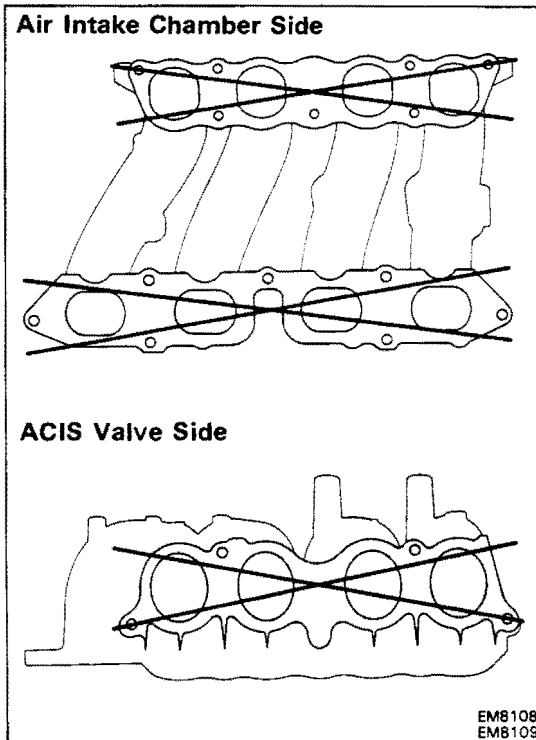

## 12. INSPECT INTAKE AND EXHAUST MANIFOLDS

### (Intake manifold (3S-GE))

Using precision straight edge and feeler gauge, measure the surfaces contacting the cylinder head, air intake chamber and ACIS valve for warpage.

**Maximum warpage: 0.20 mm (0.0079 in.)**

If warpage is greater than maximum, replace the intake manifold.

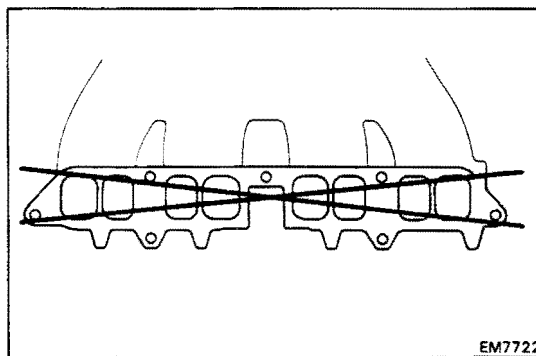

### (Intake manifold (3S-GTE))

Using precision straight edge and feeler gauge, measure the surface contacting the T-VIS valve for warpage.

**Maximum warpage: 0.20 mm (0.0079 in.)**

If warpage is greater than maximum, replace the intake manifold.

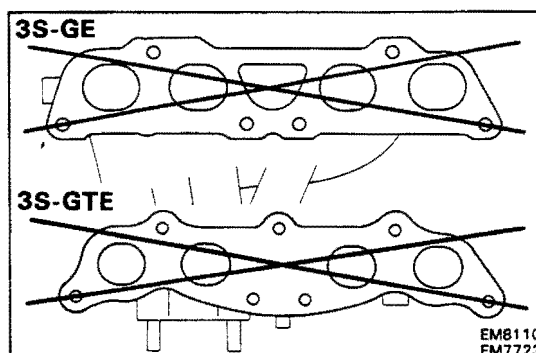

### (Exhaust manifold)

Using precision straight edge and feeler gauge, measure the surface contacting the cylinder head for warpage.

**Maximum warpage: 0.20 mm (0.0079 in.)**

If warpage is greater than maximum, replace the exhaust manifold.

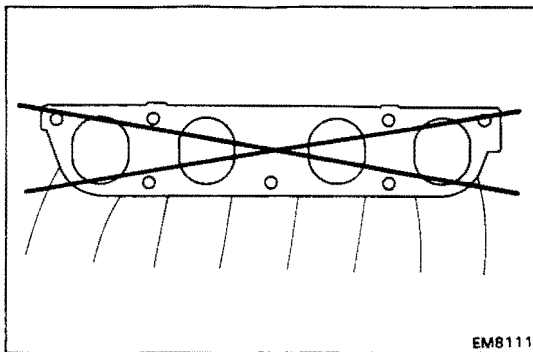

### 13. (3S-GE) INSPECT AIR INTAKE CHAMBER

Using precision straight edge and feeler gauge, measure the surface contacting the intake manifold for warpage.

**Maximum warpage: 0.20 mm (0.0079 in.)**

If warpage is greater than maximum, replace the intake chamber.

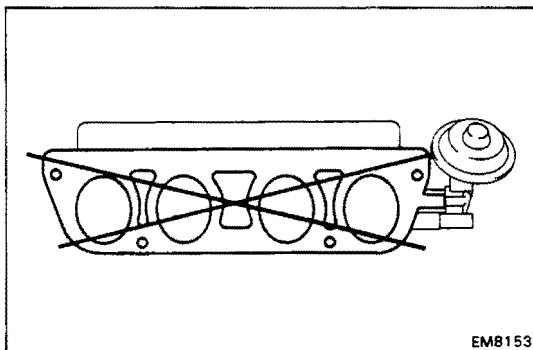

### INSPECTION OF ACOUSTIC CONTROL INDUCTION SYSTEM (ACIS) (3S-GE)

#### 1. INSPECT ACIS VALVE

##### A. Inspect for flatness

Using precision straight edge and feeler gauge, measure the surface contacting the intake manifold for warpage.

**Maximum warpage: 0.20 mm (0.0079 in.)**

If warpage is greater than maximum, replace the ACIS valve.

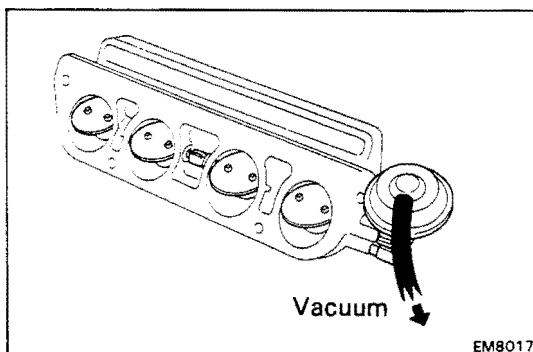

##### B. Inspect for operation

(a) With 400 mmHg (15.75 in.Hg, 53.3 kPa) of vacuum applied to the actuator, check that the control valve moves smoothly to the fully closed position.

(b) With the vacuum released, check that the control valve fully opens quickly.

If operation is not as specified, replace the ACIS valve.

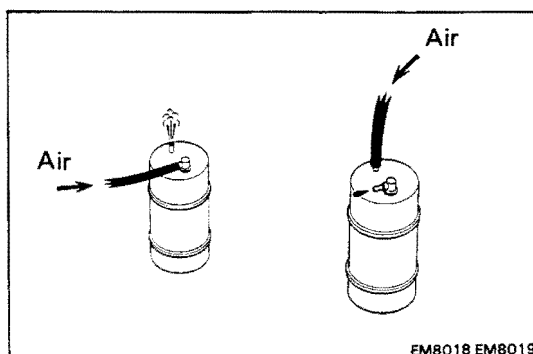

#### 2. INSPECT VACUUM TANK

(a) Check that air flows from ports A to B.

(b) Check that air does not flow from ports B to A.

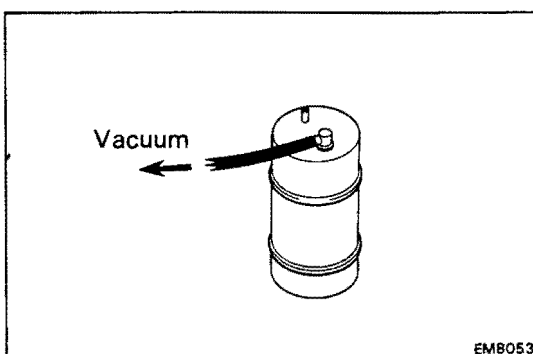

(c) Apply 500 mmHg (19.69 in.Hg, 66.7 kPa) of vacuum to port A, and check that there is no change in vacuum after one minute.

If operation is not as specified, replace the vacuum tank.

#### 3. INSPECT VACUUM SWITCHING VALVE (VSV) (See page FI-192)

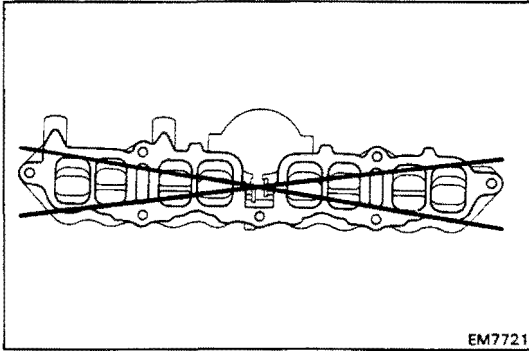

## INSPECTION OF TOYOTA – VARIABLE INDUCTION SYSTEM (T-VIS) (3S-GTE)

### 1. INSPECT T-VIS VALVE

#### A. Inspect for flatness

Using precision straight edge and feeler gauge, measure the surfaces contacting the cylinder head and intake manifold for warpage.

**Maximum warpage: 0.20 mm (0.0079 in.)**

If warpage is greater than maximum, replace the T-VIS valve.

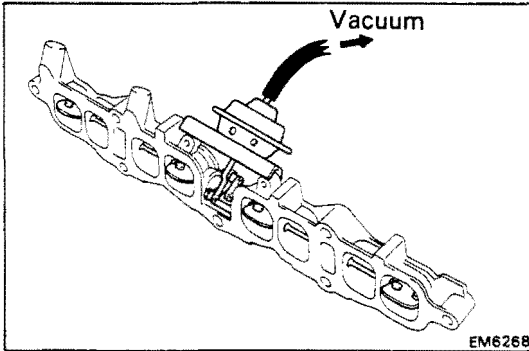

#### B. Inspect for operation

(a) With 400 mmHg (15.75 in.Hg, 53.3 kPa) of vacuum applied to the actuator, check that the control valve moves smoothly to the fully closed position.

(b) With the vacuum released, check that the control valve fully opens quickly.

If operation is not as specified, replace the T-VIS valve.

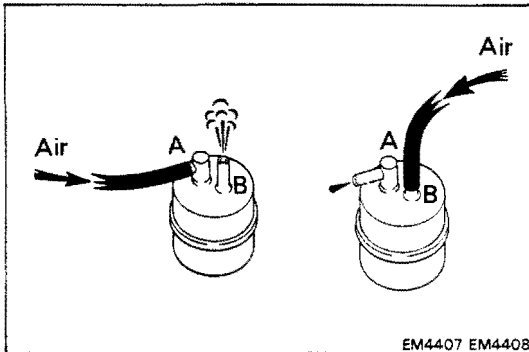

### 2. INSPECT VACUUM TANK

(a) Check that air flows from ports A to B.

(b) Check that air does not flow from ports B to A.

(c) Apply 500 mmHg (19.69 in.Hg, 66.7 kPa) of vacuum to port A, and check that there is no change in vacuum after one minute.

If operation is not as specified, replace the vacuum tank.

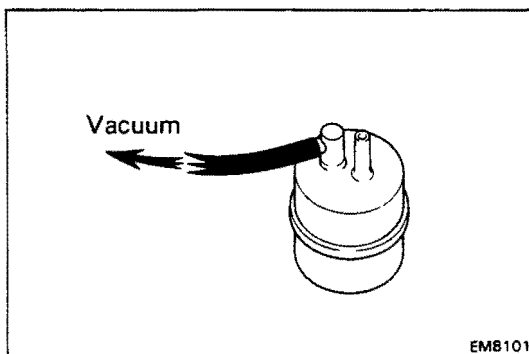

### 3. INSPECT VACUUM SWITCHING VALVE (VSV)

(See page FI-194)

**ASSEMBLY OF CYLINDER HEAD****3S-GE** (See page EM-98)**3S-GTE** (See pages EM-99 and 100)**HINT:**

- Thoroughly clean all parts to be assembled.
- Before installing the parts, apply new engine oil to all sliding and rotating surfaces.
- Replace all gaskets and oil seals with new ones.

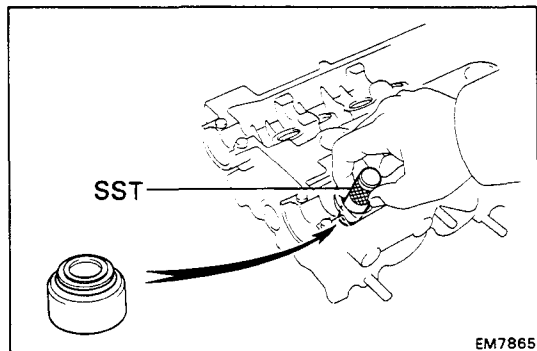
**1. INSTALL VALVES**

(a) Using SST, push in a new oil seal.

SST 09201-41020

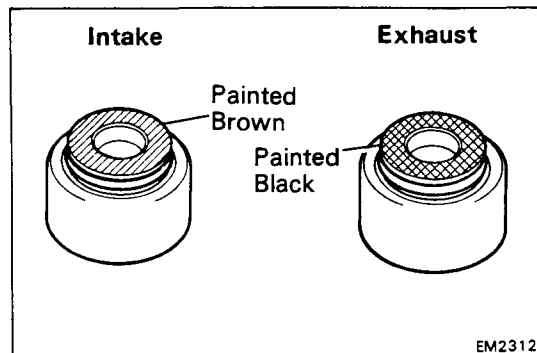
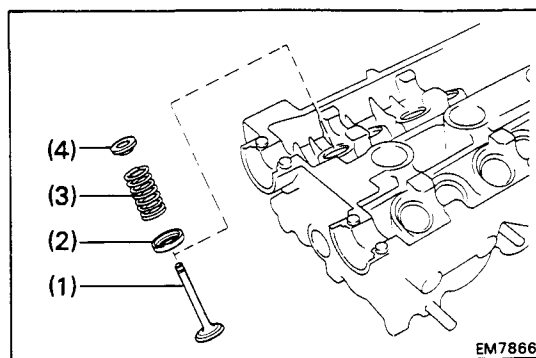
**HINT:** The intake valve oil seal is brown and the exhaust valve oil seal is black.

(b) Install the following parts:

- (1) Valve
- (2) Spring seat
- (3) Valve spring
- (4) Spring retainer

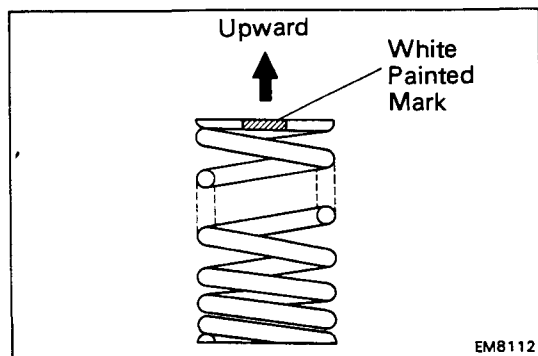
**HINT:** Install the valve spring, facing the white painted mark upward.

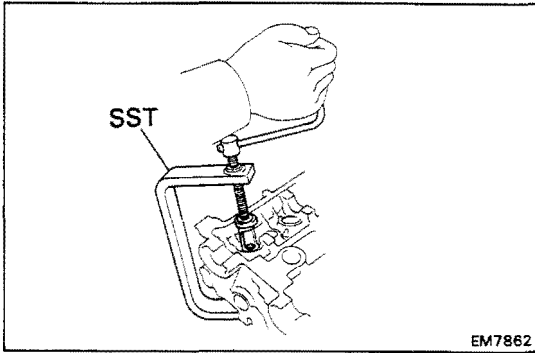

- (c) Using SST, compress the valve spring and place the two keepers around the valve stem.

SST 09202-70010

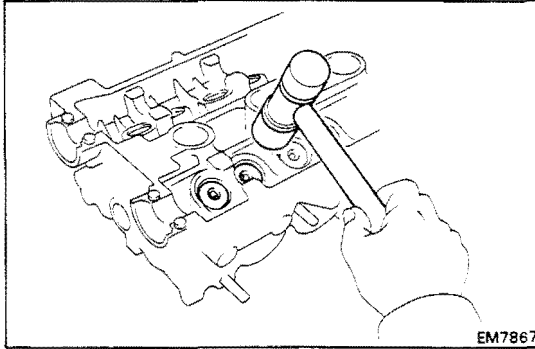

- (d) Using a plastic-faced hammer, lightly tap the valve stem tip to assure proper fit.

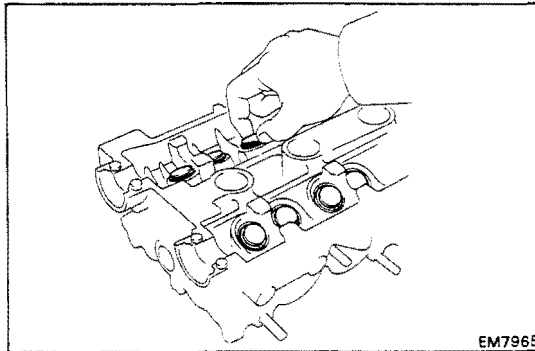

## 2. INSTALL VALVE LIFTERS AND SHIMS

- (a) Install the valve lifter and shim.  
(b) Check that the valve lifter rotates smoothly by hand.

**INSTALLATION OF CYLINDER HEAD (3S-GE)**

(See page EM-98)

1. **INSTALL CYLINDER HEAD**  
(See step 1 on page EM-138)

2. **INSTALL CAMSHAFTS**  
(See step 2 on page EM-139)

3. **ADJUST VALVE CLEARANCE** (See page EM-17)

Turn the camshaft and position the cam lobe upward, check and adjust the valve clearance.

Valve clearance (Cold):

Intake	0.15 – 0.25 mm (0.006 – 0.010 in.)
Exhaust	0.20 – 0.30 mm (0.008 – 0.012 in.)

4. **INSTALL NO.3 TIMING BELT COVER**  
(See step 4 on page EM-140)

5. **INSTALL NO.1 IDLER PULLEY**  
(See step 4 on page EM-53)

6. **INSTALL CAMSHAFT TIMING PULLEYS**  
(See steps 9 to 17 on pages EM-54 to 58)

7. **INSTALL CYLINDER HEAD COVERS**

(a) Apply seal packing to the cylinder head as shown in the figure.

Seal packing: Part No. 08826-00080 or equivalent

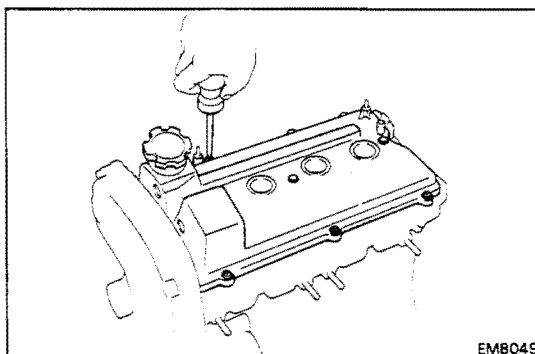
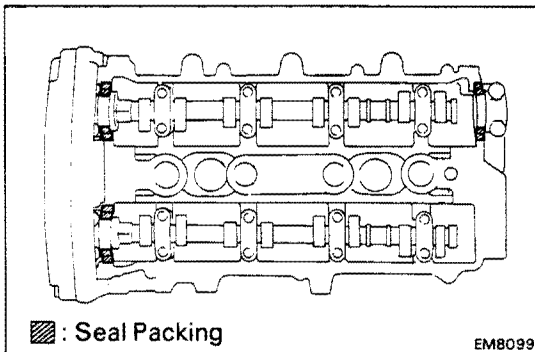

(b) Install the two gaskets to the head cover.

(c) Install the head cover with the ten seal washers and screws. Uniformly tighten the screws in several passes.

Torque: 25 kg-cm (21 in.-lb, 2.5 N)

8. **INSTALL DELIVERY PIPE AND INJECTORS**  
(See step 1 on pages FI-145 and 146)

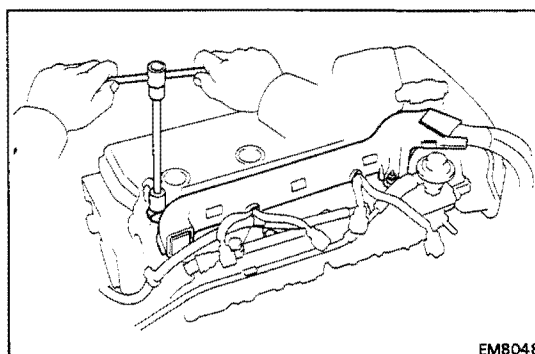

9. **INSTALL ENGINE WIRE TO CYLINDER HEAD COVER**

(a) Install the engine wire with the two bolts.

(b) Connect the four injector connectors.

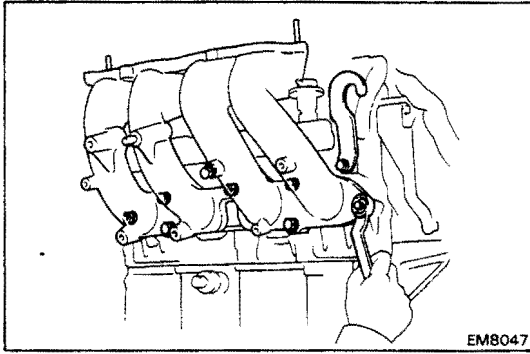
**10. INSTALL RH REAR ENGINE HANGER**

Torque: 195 kg-cm (14 ft-lb, 19 N·m)

**11. INSTALL INTAKE MANIFOLD**

- (a) Install a new gasket and the intake manifold with the four bolts and three nuts. Uniformly tighten the bolts and nuts in several passes.

Torque: 195 kg-cm (14 ft-lb, 19 N·m)

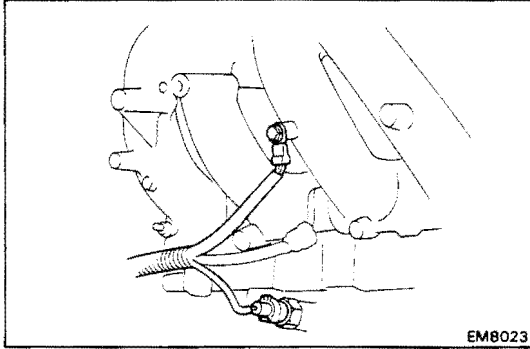

- (b) Connect the knock sensor connector.  
 (c) Connect the ground strap with the bolt.

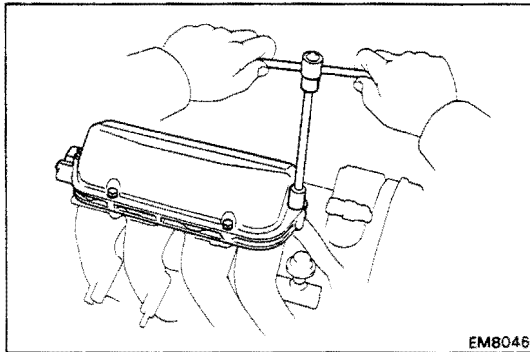
**12. INSTALL ACIS VALVE**

Install a new gasket and the ACIS valve with the two bolts and two nuts. Uniformly tighten the bolts and nuts in several passes.

Torque: 195 kg-cm (14 ft-lb, 19 N·m)

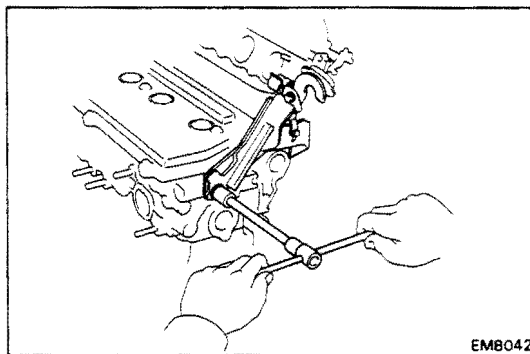
**13. INSTALL LH ENGINE HANGER**

Install the engine hanger with the two bolts

Torque:

12 mm bolt head 130 kg-cm (9 ft-lb, 13 N·m)  
 14 mm bolt head 195 kg-cm (14 ft-lb, 19 N·m)

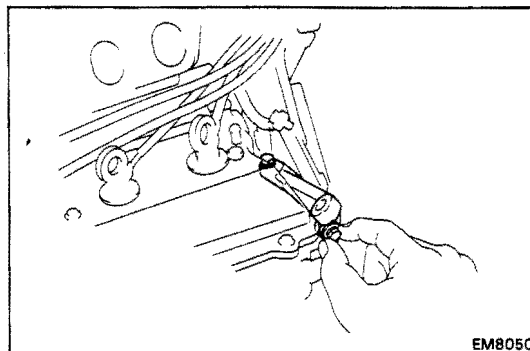
**14. INSTALL DISTRIBUTOR (See page IG-9)****15. INSTALL AIR INTAKE CHAMBER**

- (a) Temporarily install the No.1 chamber stay with the two bolts.

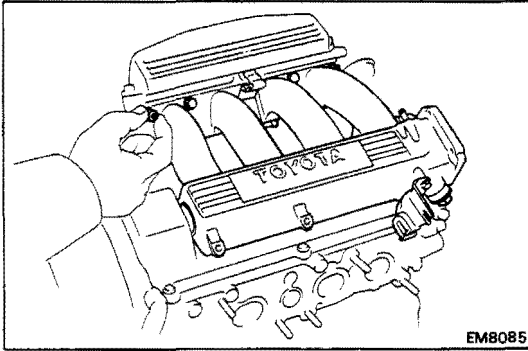

- (b) Temporarily install a new gasket and the air intake chamber with the six bolts and two nuts.

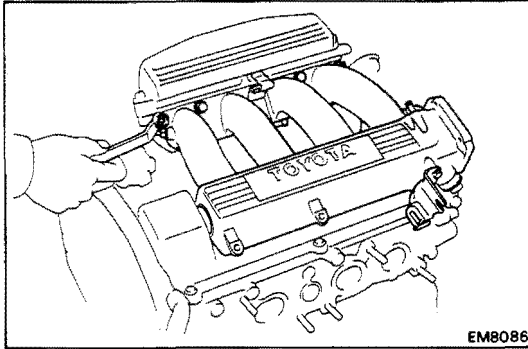

- (c) Uniformly tighten the five bolts and two nuts holding the air intake chamber and intake manifold in several passes.

**Torque: 195 kg-cm (14 ft-lb, 19 N·m)**

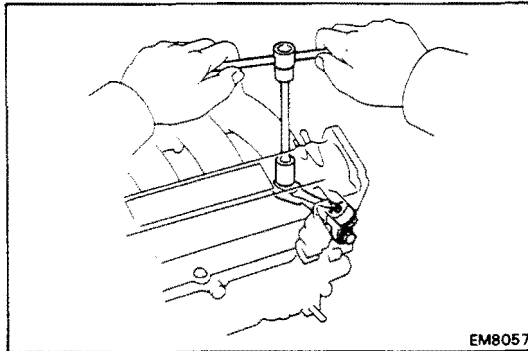

- (d) Tighten the three No.1 chamber stay bolts.

**Torque:**

**12 mm head bolt 195 kg-cm (14 ft-lb, 19 N·m)**

**14 mm head bolt 400 kg-cm (29 ft-lb, 39 N·m)**

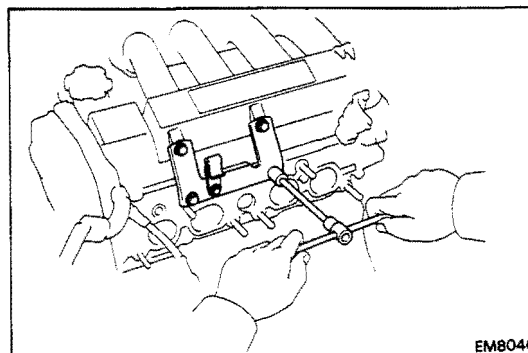

- (e) Install the No.2 chamber stay.

**Torque: 195 kg-cm (14 ft-lb, 19 N·m)**

## 16. INSTALL COLD START INJECTOR (See steps 1 to 3 on page FI-123)

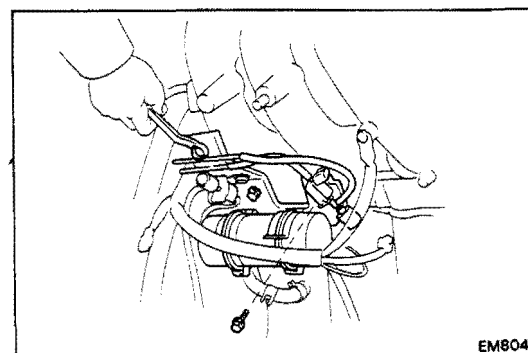

## 17. INSTALL ACIS VACUUM TANK, ACIS VSV, FUEL PRESSURE VSV AND BRACKET

- (a) Install the ACIS vacuum tank, ACIS VSV, fuel pressure VSV and bracket assembly with the three bolts.



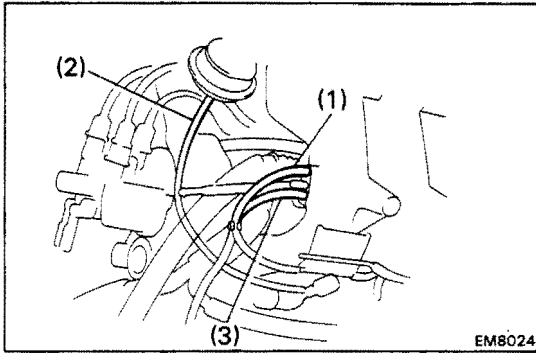

- (b) Connect the following hoses:
- (1) Vacuum hose (from fuel pressure VSV) from intake manifold
  - (2) Vacuum hose (from ACIS VSV) from ACIS actuator
  - (3) Vacuum hose (from vacuum tank) from intake manifold
- (c) Connect the following connectors:
- Fuel pressure VSV connector
  - ACIS VSV connector

### 18. INSTALL INTAKE MANIFOLD STAY

Install the manifold stay with the two bolts.

**Torque: 400 kg-cm (29 ft-lb, 39 N·m)**

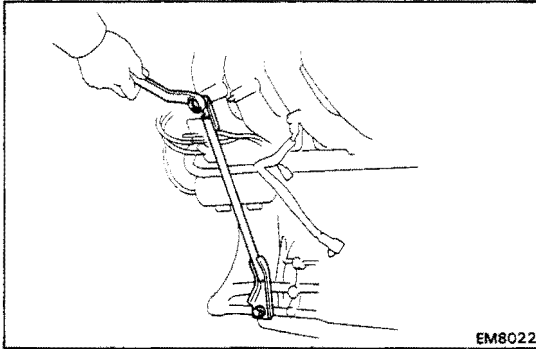

### 19. INSTALL AIR TUBE

- (a) Install the air tube with the two bolts.

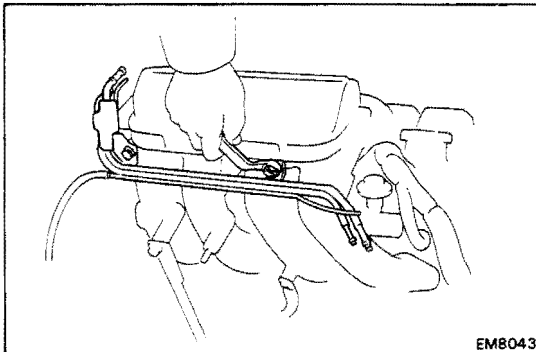

- (b) Connect the following hoses:
- (1) Vacuum sensing hose from fuel pressure regulator
  - (2) Two PS vacuum hoses

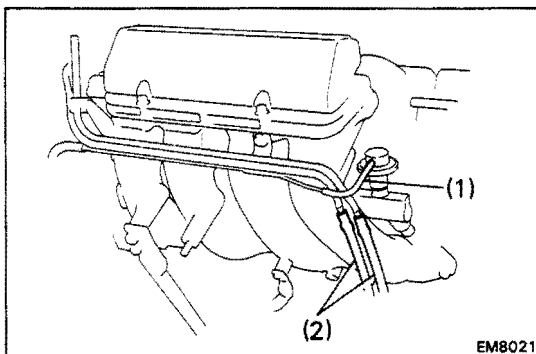

- (3) Two vacuum hoses from air intake chamber
- (4) Vacuum hose from vacuum pipe (from fuel pressure VSV)

### 20. INSTALL THROTTLE BODY

(See steps 2 to 6 on page FI-168)

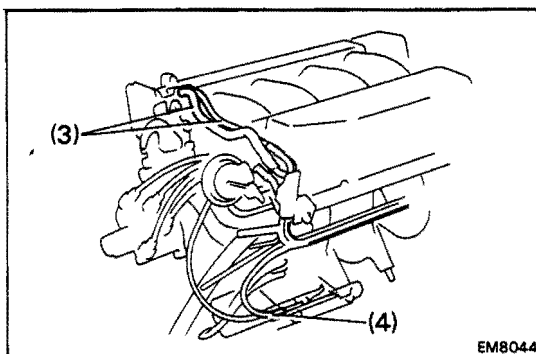

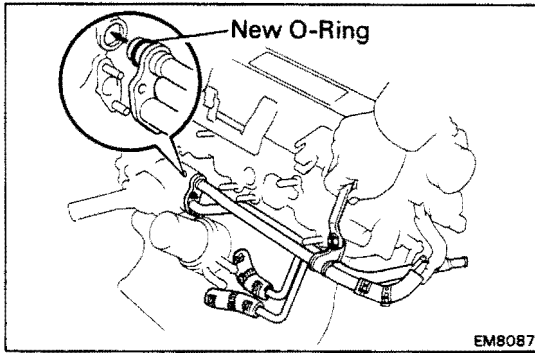
**21. INSTALL WATER BY-PASS PIPE**

- (a) Install a new O-ring to the by-pass pipe.
- (b) Apply soapy water on the O-ring.
- (c) Install a new gasket to the water pump.
- (d) Install the water by-pass pipe with the two nuts and two bolts.

**Torque (Nut): 80 kg-cm (69 in.-lb, 7.8 N·m)**

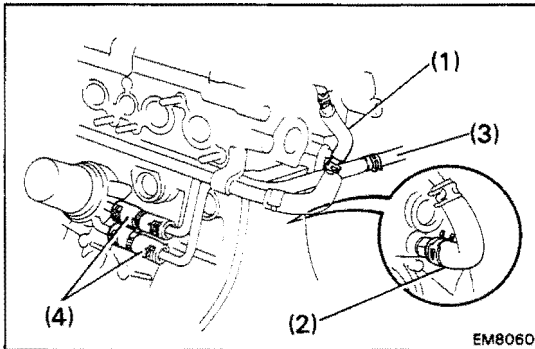

- (e) Connect the following hoses:
  - (1) Water by-pass hose from ISC valve
  - (2) Water by-pass hose from cylinder block
  - (3) Two water by-pass hoses from oil cooler
  - (4) Heater water hose

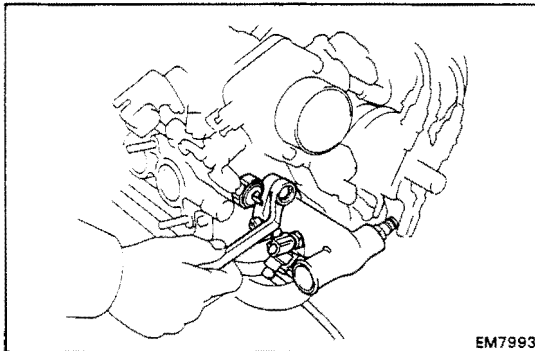
**22. INSTALL OIL PRESSURE SWITCH**

Apply adhesive to two or three threads.

**Adhesive: Part No. 08833-00080, THREE BOND 1324 or equivalent**

**23. INSTALL WATER OUTLET**

- (a) Install a new gasket and the water outlet with the two bolts.

**Torque: 400 kg-cm (29 ft-lb, 39 N·m)**

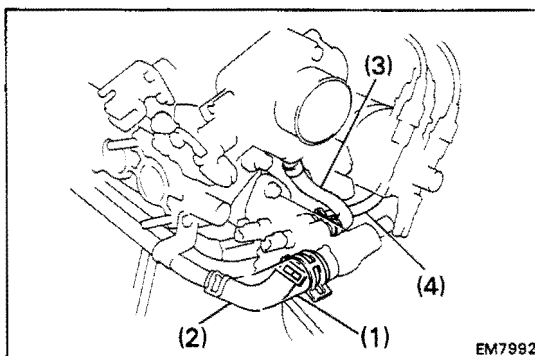

- (b) Connect the following hoses:
  - (1) Upper radiator hose
  - (2) Water by-pass hose from water by-pass pipe
  - (3) Water by-pass pipe hose from ISC valve
  - (4) Heater water hose
- (c) Disconnect the following connectors:
  - Water temperature sender gauge connector
  - Water temperature sensor
  - Cold start injector time switch connector

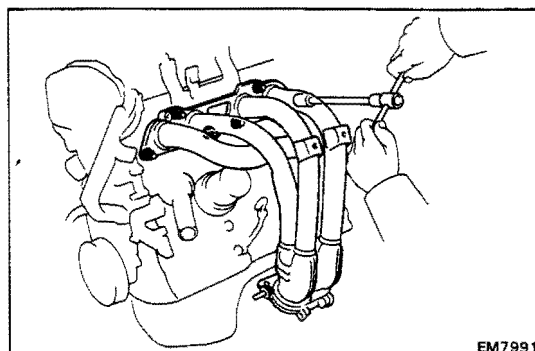
**24. INSTALL EXHAUST MANIFOLD**

- (a) Install two new gaskets and the exhaust manifold with the six nuts. Uniformly tighten the nuts in several passes.

**Torque: 440 kg-cm (32 ft-lb, 43 N·m)**

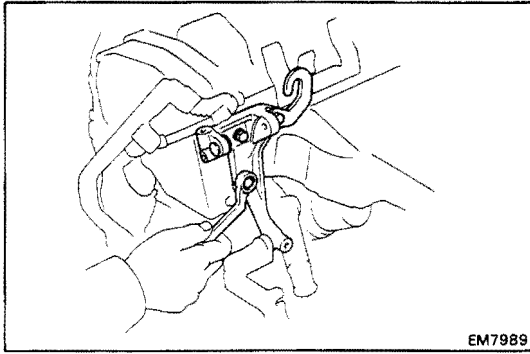

- (b) Install the RH manifold stay with the three bolts and nut.

**Torque:** Bolt 600 kg-cm (43 ft-lb, 59 N·m)  
Nut 440 kg-cm (32 ft-lb, 43 N·m)

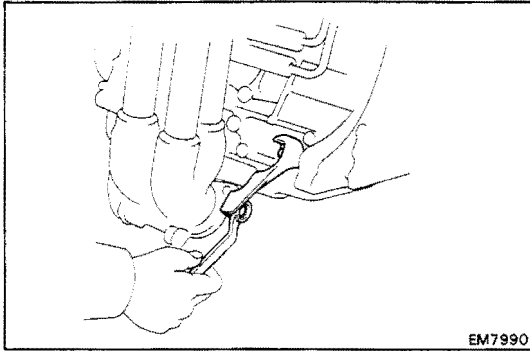

- (c) Install the LH manifold stay with the two bolts.

**Torque:** 600 kg-cm (43 ft-lb, 59 N·m)

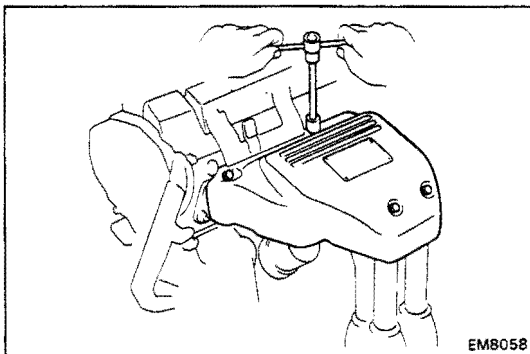

- (d) Install the heat insulator with the five bolts.

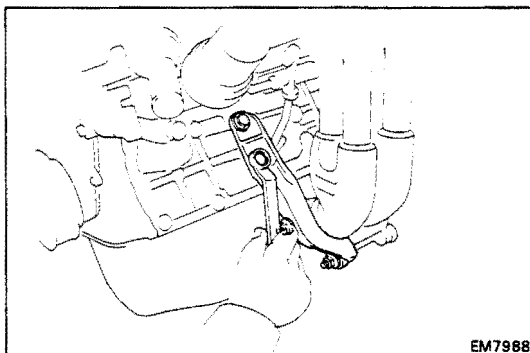

## 25. INSTALL NO.1 ALTERNATOR BRACKET AND RH FRONT ENGINE HANGER

Install the alternator bracket and engine hanger with the three bolts.

**Torque:** 400 kg-cm (29 ft-lb, 39 N·m)

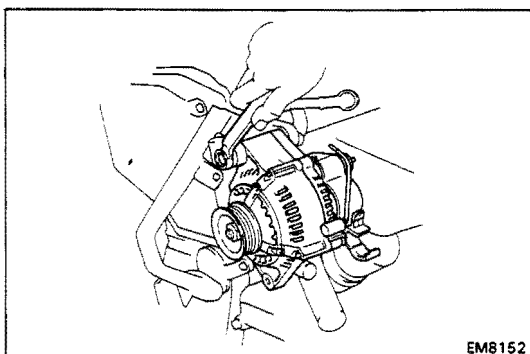

## 26. INSTALL ALTERNATOR

- (a) Install the alternator with the two bolts.

**Torque:**

12 mm head bolt 195 kg-cm (14 ft-lb, 19 N·m)

14 mm head bolt 530 kg-cm (38 ft-lb, 52 N·m)

- (b) Connect the alternator connector.

- (c) Connect the alternator wire with the nut.

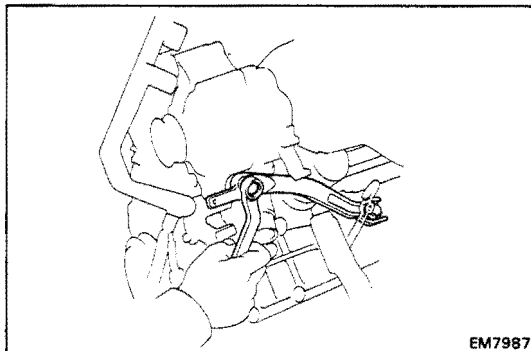

- (d) Install the No.2 alternator bracket with the two bolts.  
Torque: 400 kg-cm (29 ft-lb, 39 N·m)

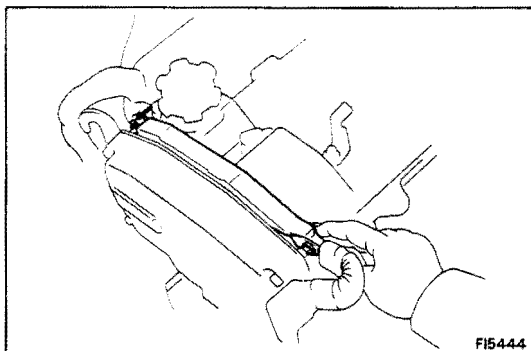

- (e) Install the two clamps of the engine wire to each No.2 timing belt cover bolt.

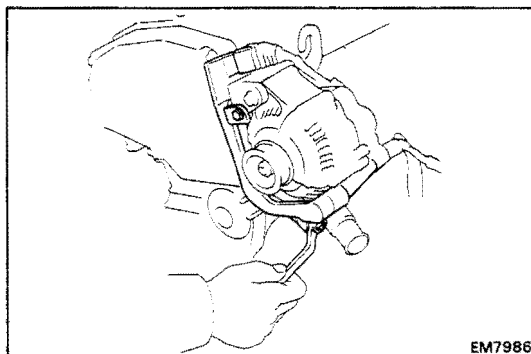

- (f) Install the engine wire with the two bolts.  
(g) Install the drive belt.

**27. FILL ENGINE WITH COOLANT**

**28. START ENGINE AND CHECK FOR LEAKS**

**29. ADJUST IGNITION TIMING (See page EM-23)**

Ignition timing:

10° BTDC @ idle

(w/ Terminals TE1 and E1 connected)

**30. RECHECK ENGINE COOLANT AND OIL LEVELS**

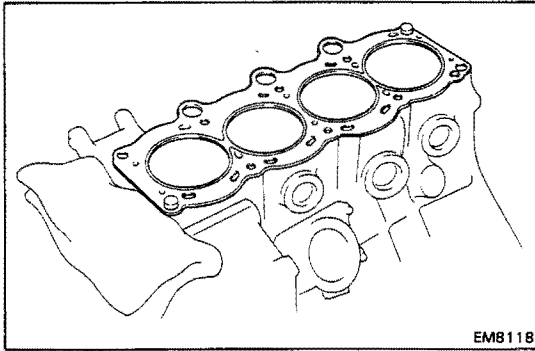

## INSTALLATION OF CYLINDER HEAD (3S-GTE)

(See pages EM-99 and 100)

### 1. INSTALL CYLINDER HEAD

#### A. Place cylinder head on cylinder block

- (a) Place a new cylinder head gasket in position on the cylinder block.

**NOTICE:** Be careful of the installation direction.

- (b) Place the cylinder head in position on the cylinder head gasket.

#### B. Install cylinder head bolts

**HINT:**

- The cylinder head bolts are tightened in two progressive steps (steps (b) and (d)).
  - If any cylinder head bolt is broken or deformed, replace it.
- (a) Apply a light coat of engine oil on the threads and under the heads of the cylinder head bolts.
- (b) Using SST, install and uniformly tighten the ten cylinder head bolts in several passes in the sequence shown.

SST 09043-38100

**Torque: 500 kg-cm (36 ft-lb, 49 N·m)**

If any one of the cylinder head bolts does not meet the torque specification, replace the cylinder head bolt.

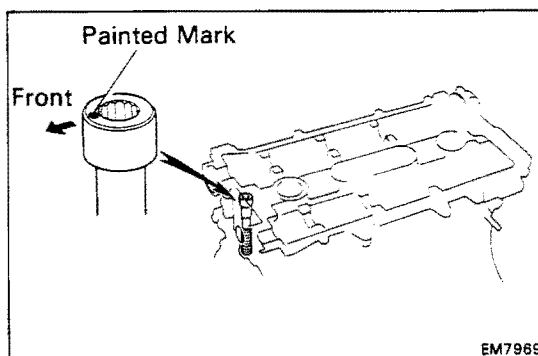
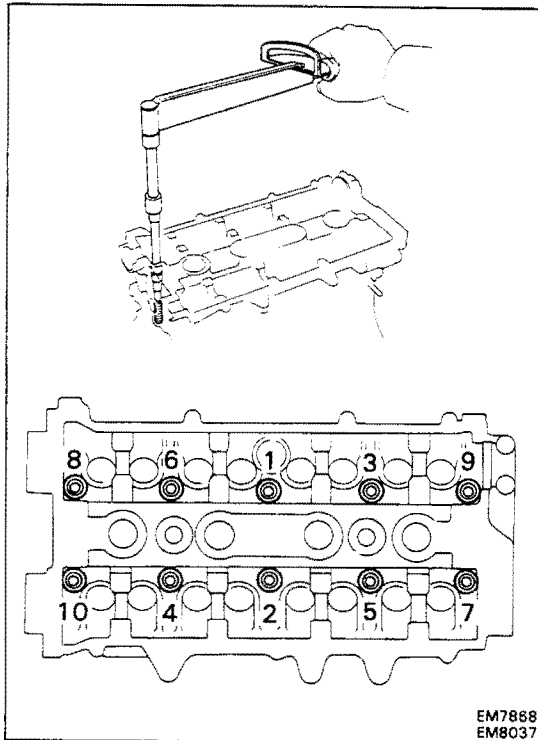

- (c) Mark the front of the cylinder head bolt head with paint.

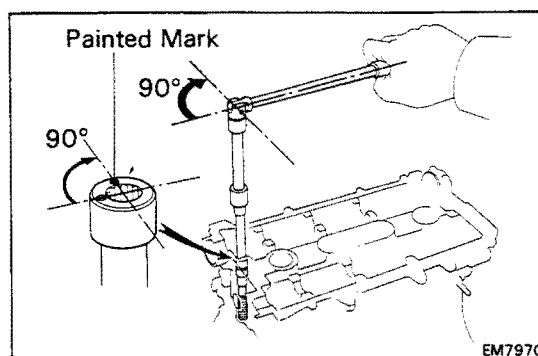

- (d) Retighten the cylinder head bolts 90° in the numerical order shown.
- (e) Check that the painted mark is now at a 90° angle to front.

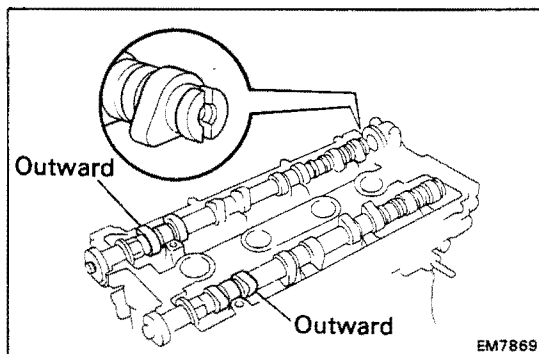

## 2. INSTALL CAMSHAFTS

- (a) Place the camshaft on the cylinder head with the No.1 cam lobe facing outward as shown.

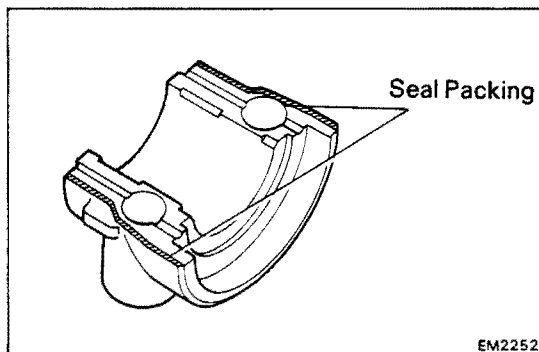

- (b) Apply seal packing to the No.1 bearing cap as shown.  
**Seal packing: Part No. 08826-00080 or equivalent**

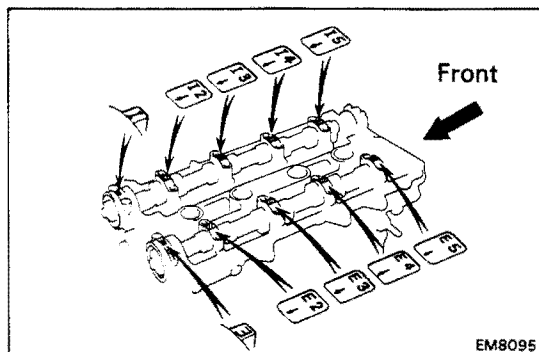

- (c) Install the bearing caps in their proper locations.  
**HINT: Each bearing cap has a number and front mark.**

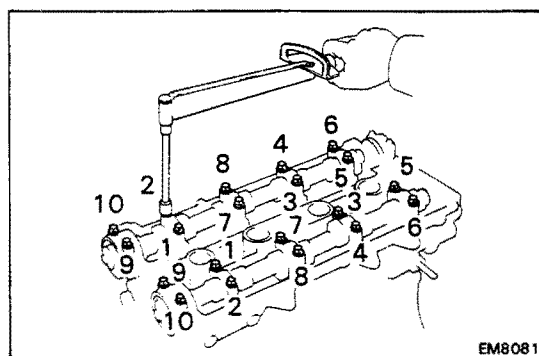

- (d) Apply a light coat of engine oil on the threads and under the heads of the bearing cap bolts.  
 (e) Install and uniformly tighten the ten bearing cap bolts on one side in several passes in the sequence shown.

**Torque: 190 kg-cm (14 ft-lb, 19 N·m)**

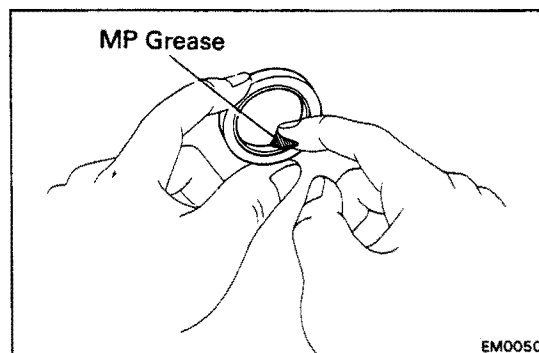

- (f) Apply MP grease to a new oil seal lip.

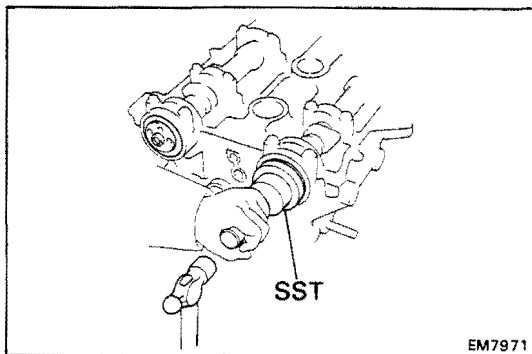

- (g) Using SST, tap in the two camshaft oil seals.  
SST 09223-50010

### 3. ADJUST VALVE CLEARANCE (See page EM-17)

Turn the camshaft and position the cam lobe upward, check and adjust the valve clearance.

Valve clearance (Cold):

Intake	0.15 – 0.25 mm (0.006 – 0.010 in.)
Exhaust	0.20 – 0.30 mm (0.008 – 0.012 in.)

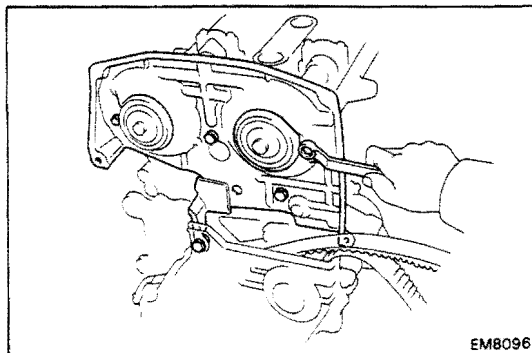

### 4. INSTALL NO.3 TIMING BELT COVER

Install the No.3 belt cover with the five bolts.

Torque: 90 kg-cm (78 in.-lb, 8.8 N)

### 5. INSTALL NO.1 IDLER PULLEY (See step 4 on page EM-53)

### 6. INSTALL CAMSHAFT TIMING PULLEYS (See steps 9 to 17 on pages EM-54 to 58)

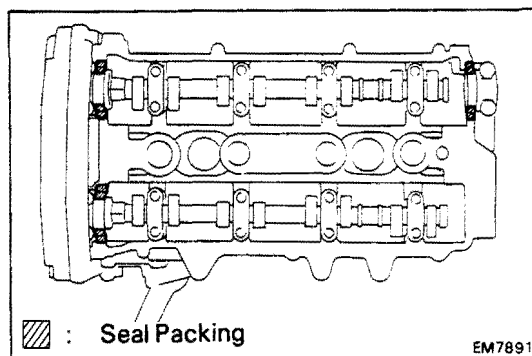

### 7. INSTALL CYLINDER HEAD COVERS

- (a) Apply seal packing to the cylinder head as shown in the figure.

Seal packing: Part No. 08826-00080 or equivalent

- (b) Install the two gaskets to the head cover.

- (c) Install the head cover with the twelve seal washers and screws. Uniformly tighten the screws in several passes.

Torque: 25 kg-cm (21 in.-lb, 2.5 N)

### 8. INSTALL DELIVERY PIPE AND INJECTORS (See steps 1 to 4 on page FI-154)

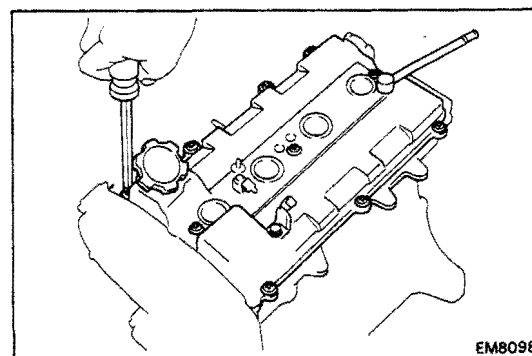

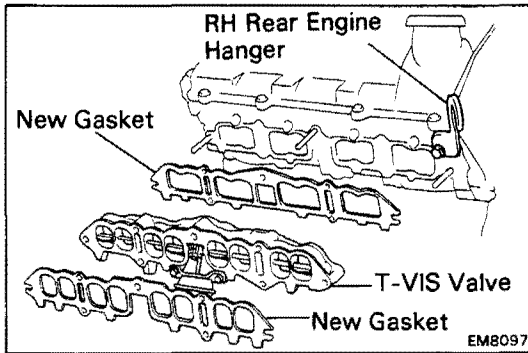
**9. INSTALL RH REAR ENGINE HANGER**

Torque: 195 kg-cm (14 ft-lb, 19 N·m)

**10. INSTALL T-VIS VALVE AND INTAKE MANIFOLD**

- (a) Place a new gasket, the T-VIS valve and the other new gasket on the cylinder head.

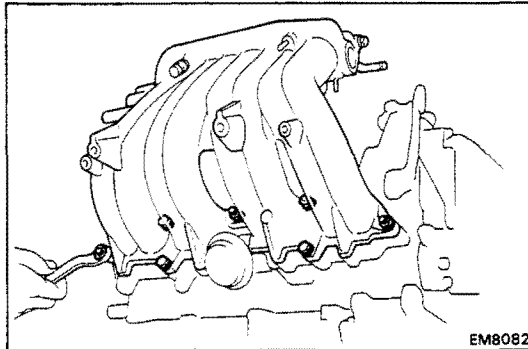

- (b) Install the intake manifold with the four bolts and three nuts. Uniformly tighten the bolts and nuts in several passes.

Torque: 195 kg-cm (14 ft-lb, 19 N·m)

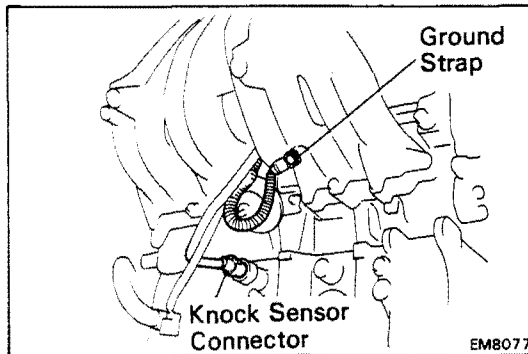

- (c) Connect the knock sensor connector.  
(d) Connect the ground strap with the bolt.

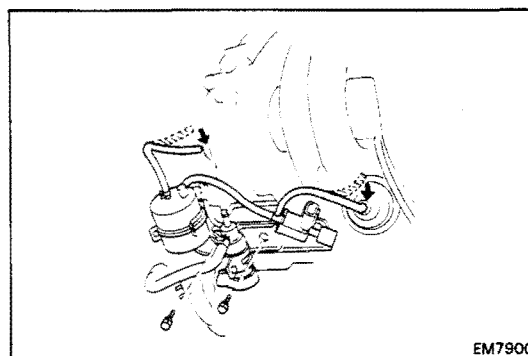
**11. INSTALL T-VIS VACUUM TANK, T-VIS VSV, TURBOCHARGING PRESSURE VSV AND BRACKET**

- (a) Install the T-VIS vacuum tank, T-VIS VSV, turbocharging pressure VSV and bracket assembly with the two bolts.

- (b) Connect the following hoses:

- (1) Vacuum hose (from T-VIS VSV) from T-VIS actuator
- (2) Vacuum hose (from T-VIS vacuum tank) from intake manifold

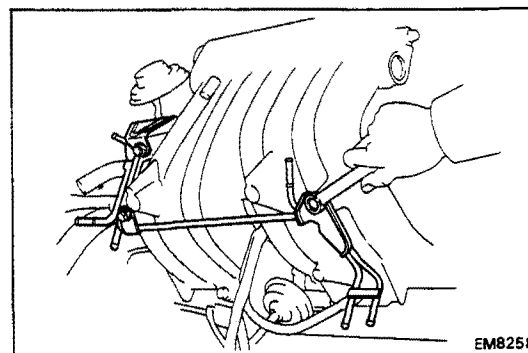
**12. INSTALL NO.1 AIR TUBE**

- (a) Install the air tube with the three bolts.



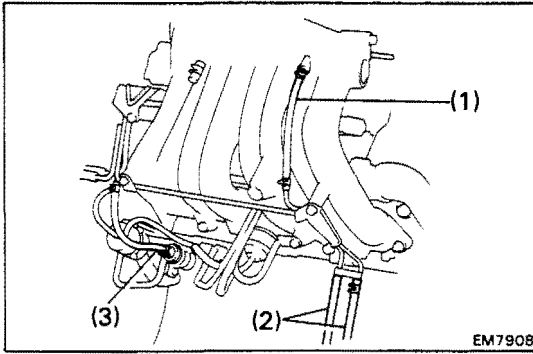

- (b) Connect the following hoses:
- (1) Vacuum hose from intake manifold
  - (2) Two PS vacuum hoses
  - (3) Vacuum hose from turbocharging pressure VSV

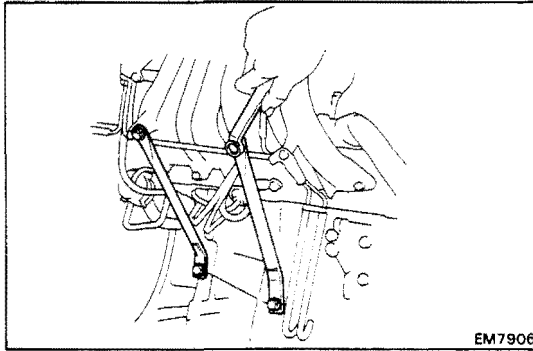

### 13. INSTALL INTAKE MANIFOLD STAYS

Install the manifold stay with the two bolts.

Install the two manifold stays

**Torque: 260 kg-cm (19 ft-lb, 25 N·m)**

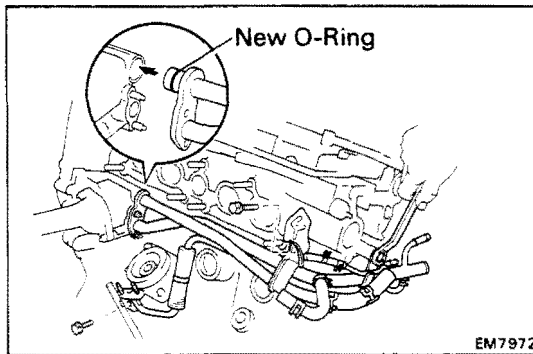

### 14. INSTALL WATER BY-PASS PIPE

- (a) Install a new O-ring to the pipe.
- (b) Apply soapy water on the O-ring.
- (c) Install a new gasket to the water pump.
- (d) Install the water by-pass pipe with the two nuts and two bolts.

**Torque (Nuts): 80 kg-cm (69 in.-lb, 7.8 N·m)**

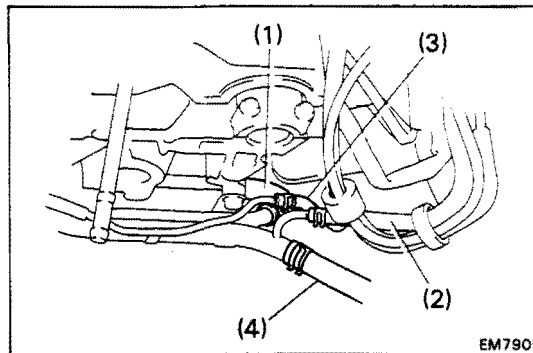

- (e) Connect the following hoses:
- (1) Water by-pas hose from cylinder block
  - (2) water by-pass hoses from No.1 air tube
  - (3) Vacuum hose from turbocharging pressure VSV
  - (4) Heater water hose

### 15. INSTALL OIL COOLER

(See steps 2 to 4 on pages LU-21 and 22)

### 16. INSTALL OIL PRESSURE SWITCH

Apply adhesive to two or three threads.

**Adhesive: Part No. 08833-00080, THREE BOND 1324 or equivalent**

### 17. INSTALL WATER OUTLET

- (a) Install a new gasket and the water outlet with the two bolts.

**Torque: 400 kg-cm (29 ft-lb, 39 N·m)**

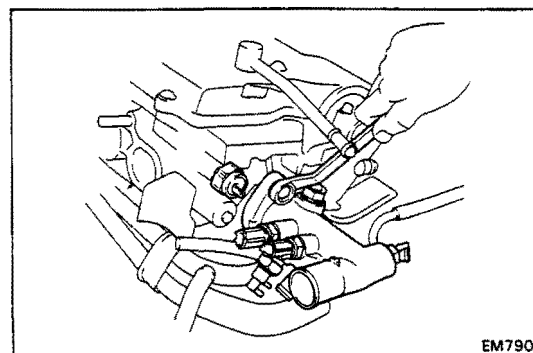

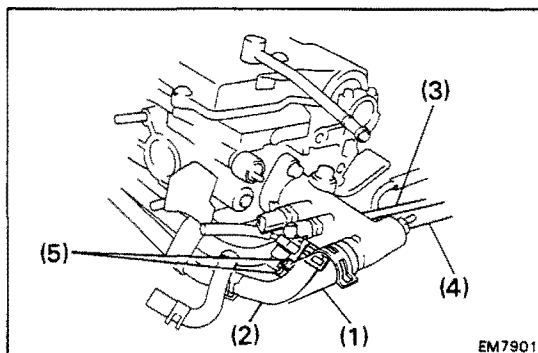

- (b) Connect the following hoses:
- (1) Upper radiator hose
  - (2) Water by-pass hose from water by-pass pipe
  - (3) Water by-pass pipe hose from ISC valve
  - (4) Heater water hose
  - (5) Two EVAP VSV vacuum hoses

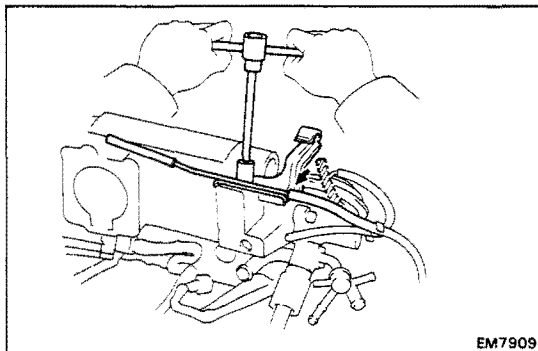

#### 18. INSTALL VACUUM PIPE

- (a) Install the vacuum pipe with the bolt.
- (b) Connect the vacuum hose to the vacuum pipe.

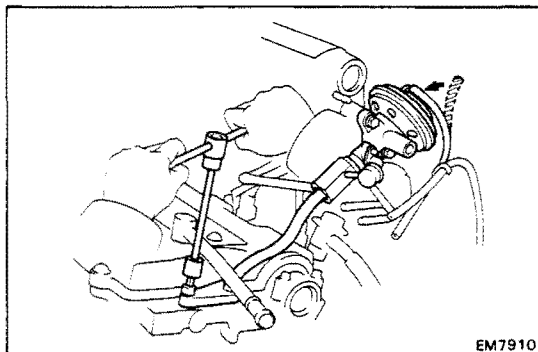

#### 19. INSTALL EGR VALVE AND PIPE

- (a) Install two new gaskets, the EGR valve and pipe assembly with the four bolts.

**Torque: 195 kg-cm (14 ft-lb, 19 N·m)**

- (b) Connect the vacuum hose to the EGR valve.

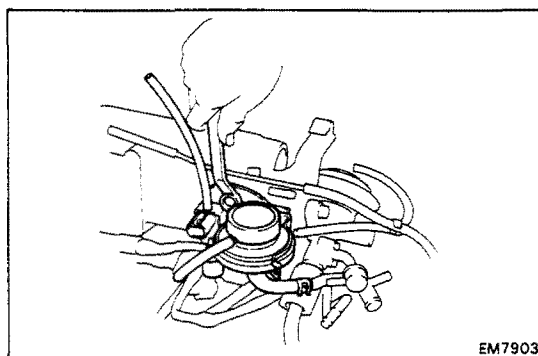

#### 20. INSTALL EGR VACUUM MODULATOR AND VSV

- (a) Install the EGR vacuum modulator and VSV assembly with the bolt.

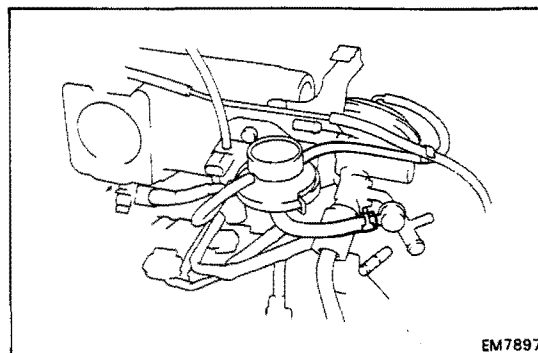

- (b) Connect the two vacuum hoses to the EGR valve.
- (c) Connect the EGR VSV connector.

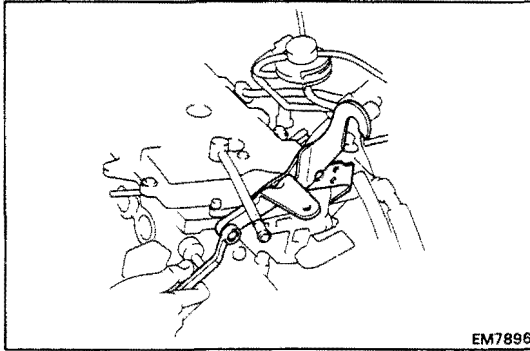
**21. INSTALL LH ENGINE HANGER**

Install the LH engine hanger and reservoir tank with the two bolts.

**Torque:**

12 mm head bolt 130 kg-cm (9 ft-lb, 13 N·m)  
 14 mm head bolt 195 kg-cm (14 ft-lb, 19 N·m)

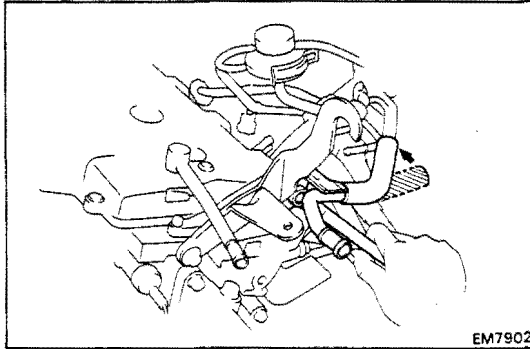
**22. INSTALL NO.2 AIR TUBE**

- (a) Install the air tube with the bolt.
- (b) Connect the air hose to the No.1 air tube.

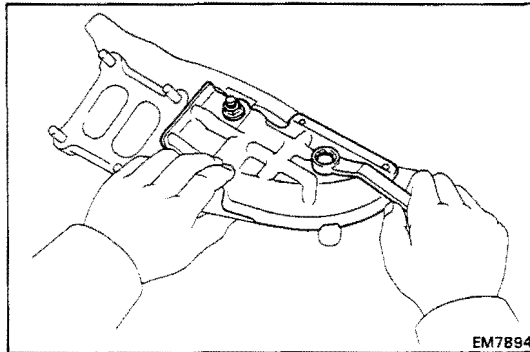
**23. INSTALL DISTRIBUTOR (See page IG-17)****24. INSTALL EXHAUST MANIFOLD**

- (a) Install the heat insulator with the bolt and nut.

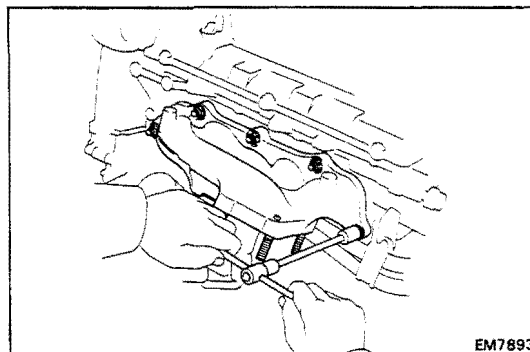

- (b) Install a new gasket and the exhaust manifold with the seven nuts. Uniformly tighten the nuts in several passes.

**Torque: 530 kg-cm (38 ft-lb, 52 N·m)**

**25. INSTALL COLD START INJECTOR (See steps 1 to 3 on page FI-126)****26. INSTALL THROTTLE BODY (See steps 1 to 7 on pages FI-172 and 173)****27. INSTALL TURBOCHARGER (See steps 5 to 10 on pages TC-14 to 16)**

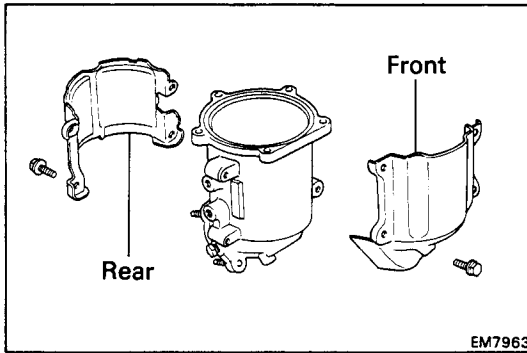
**28. INSTALL CATALYTIC CONVERTER**

- (a) Install the front heat insulator with the five bolts.
- (b) Install the rear heat insulator with the four bolts.

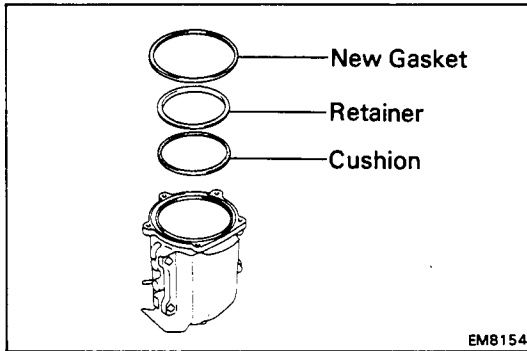

- (c) Place the cushion, retainer and new gasket on the catalytic converter.

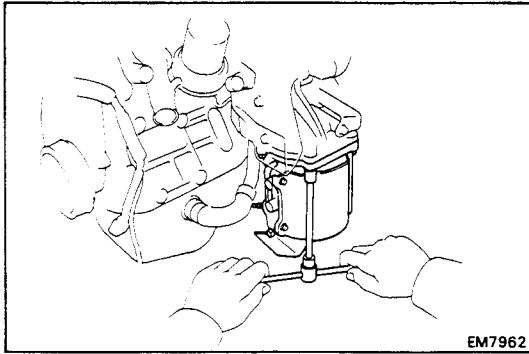

- (d) Install the catalytic converter with the three bolts and two nuts.

**Torque: 300 kg-cm (22 ft-lb, 29 N·m)**

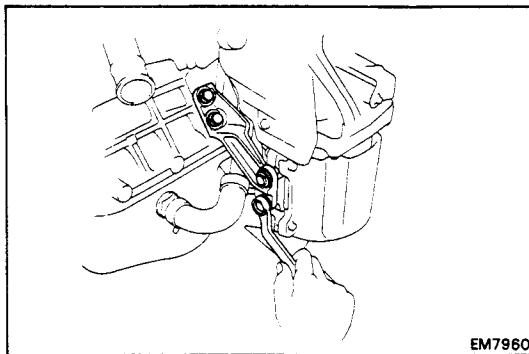

- (e) Install the RH converter stay with the four bolts.

**Torque: 600 kg-cm (43 ft-lb, 59 N·m)**

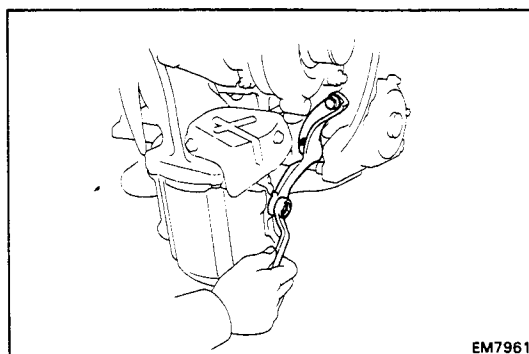

- (f) Install the LH converter stay with the three bolts.

**Torque: 600 kg-cm (43 ft-lb, 59 N·m)**

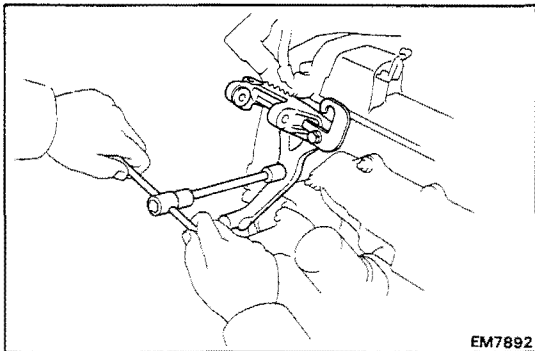

### 29. INSTALL NO.1 ALTERNATOR BRACKET AND RH FRONT ENGINE HANGER

Install the alternator bracket and engine hanger with the three bolts.

**Torque: 400 kg-cm (29 ft-lb, 39 N·m)**

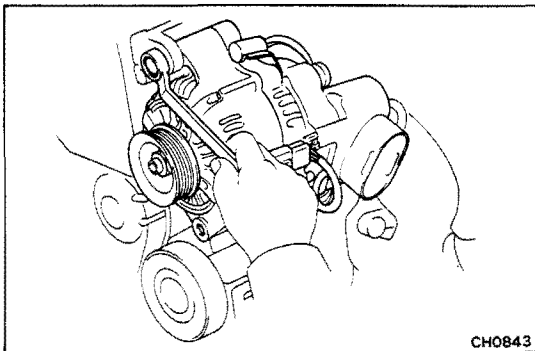

### 30. INSTALL ALTERNATOR

(a) Install the alternator with the two bolts.

**Torque:**

**12 mm head bolt 195 kg-cm (14 ft-lb, 19 N·m)**

**14 mm head bolt 530 kg-cm (38 ft-lb, 52 N·m)**

(b) Connect the alternator wire with the nut.

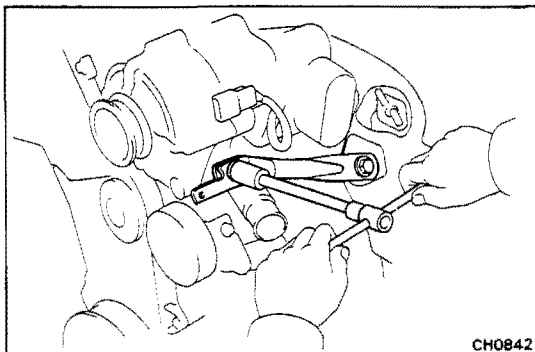

(c) Install the No.2 alternator bracket with the two bolts.

**Torque:**

**To turbine outlet elbow**

**440 kg-cm (32 ft-lb, 43 N·m)**

**To No.1 alternator bracket**

**400 kg-cm (29 ft-lb, 39 N·m)**

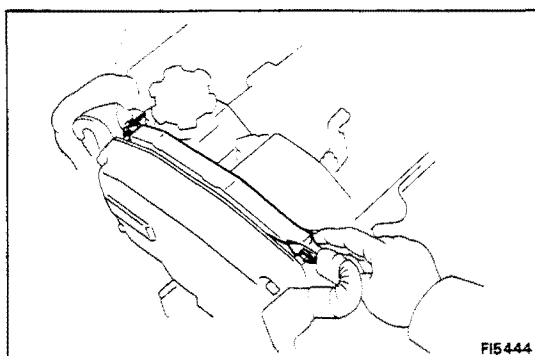

(d) Install the two clamps of the engine wire to each No.2 timing belt cover bolt.

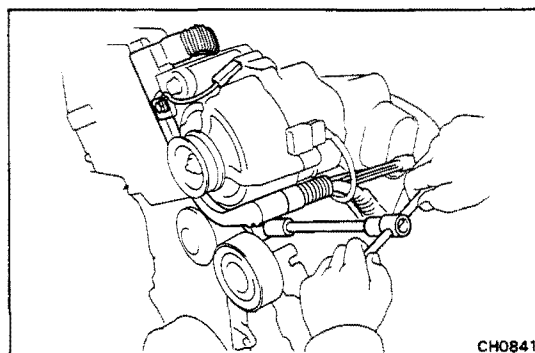

(e) Install the engine wire with the two bolts.

(f) Connect the alternator connector to the lead wire.

(g) Install the drive belt.

- 31. INSTALL INTERCOOLER**  
(See steps 11 to 13 on page TC-16)
- 32. FILL ENGINE WITH COOLANT**
- 33. START ENGINE AND CHECK FOR LEAKS**
- 34. ADJUST IGNITION TIMING (See page EM-23)**  
Ignition timing:  
10° BTDC @ idle  
(w/ Terminals TE1 and E1 connected)
- 35. RECHECK ENGINE COOLANT AND OIL LEVELS**

# CYLINDER BLOCK (5S-FE)

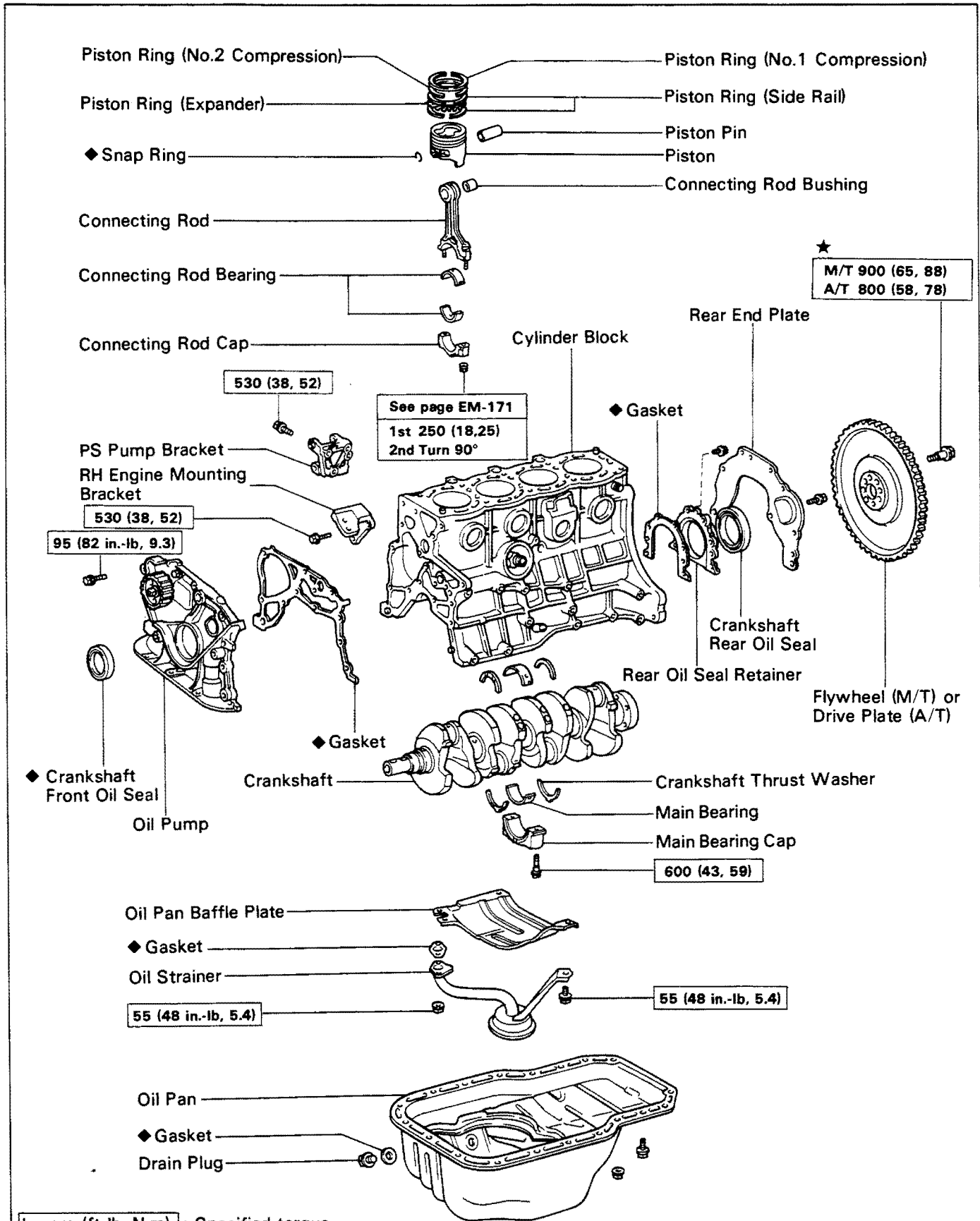

kg-cm (ft-lb, N-m) : Specified torque

◆ Non-reusable part

★ Precoated part

**PREPARATION FOR DISASSEMBLY**

1. (M/T)  
REMOVE CLUTCH COVER AND DISC
2. (M/T)  
REMOVE FLYWHEEL
3. (A/T)  
REMOVE DRIVE PLATE

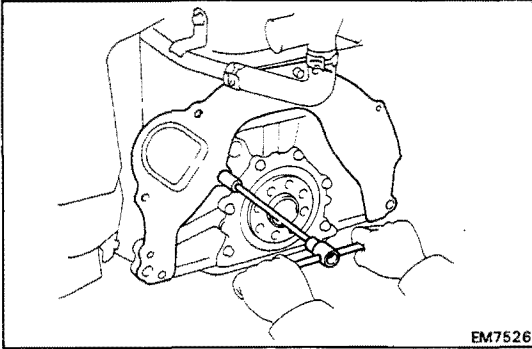

4. REMOVE REAR END PLATE  
Remove the bolt and end plate.
5. INSTALL ENGINE TO ENGINE STAND FOR DISASSEMBLY

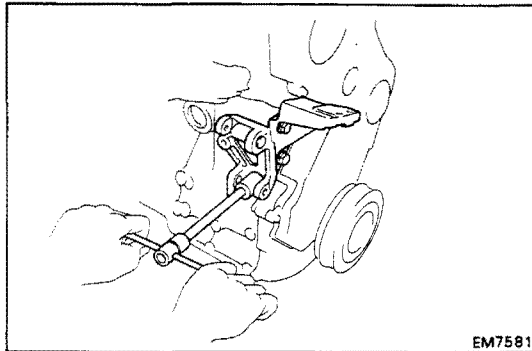

6. REMOVE RH ENGINE MOUNTING BRACKET  
Remove the three bolts and mounting bracket.
7. REMOVE PS PUMP BRACKET  
Remove the three bolts and PS pump bracket.

8. REMOVE TIMING BELT AND PULLEYS  
(See pages EM-33 to 38)
9. REMOVE CYLINDER HEAD (See pages EM-65 to 73)
10. REMOVE WATER PUMP AND ALTERNATOR  
ADJUSTING BAR  
(See pages CO-7 and 8)
11. REMOVE OIL PAN AND OIL PUMP  
(See pages LU-9 and 10)
12. REMOVE OIL FILTER (See page LU-7)
13. (w/ OIL COOLER)  
REMOVE OIL COOLER (See pages LU-16 and 17)



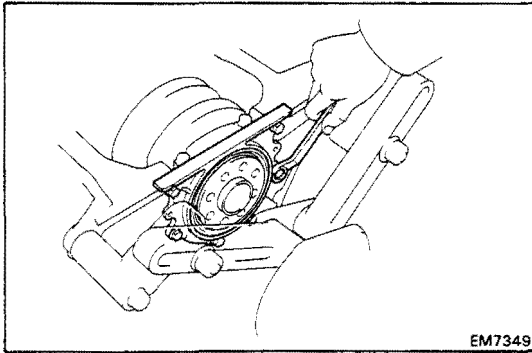

EM7349

## DISASSEMBLY OF CYLINDER BLOCK

(See page EM-148)

### 1. REMOVE REAR OIL SEAL RETAINER

Remove the six bolts, retainer and gasket.

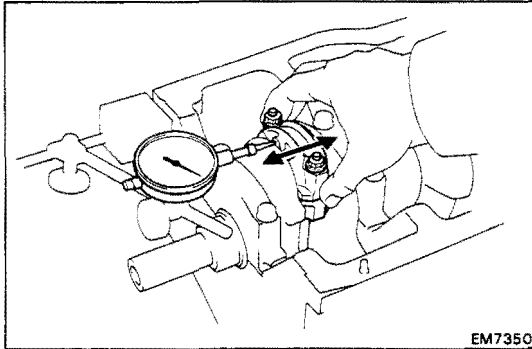

EM7350

### 2. CHECK CONNECTING ROD THRUST CLEARANCE

Using a dial indicator, measure the thrust clearance while moving the connecting rod back and forth.

**Standard thrust clearance:** 0.160 – 0.312 mm  
(0.0063 – 0.0123 in.)

**Maximum thrust clearance:** 0.35 mm (0.0138 in.)

If the thrust clearance is greater than maximum, replace the connecting rod assembly. If necessary, replace the crankshaft.

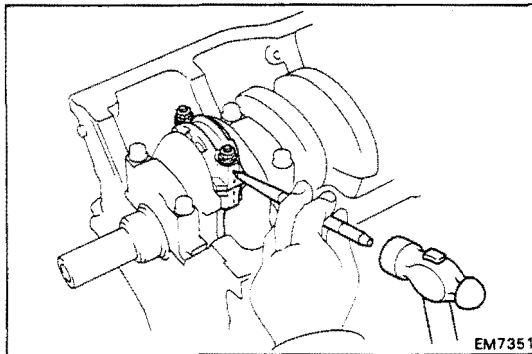

EM7351

### 3. REMOVE CONNECTING ROD CAPS AND CHECK OIL CLEARANCE

(a) Using a punch or numbering stamp, place the matchmarks on the connecting rod and cap to ensure correct reassembly.

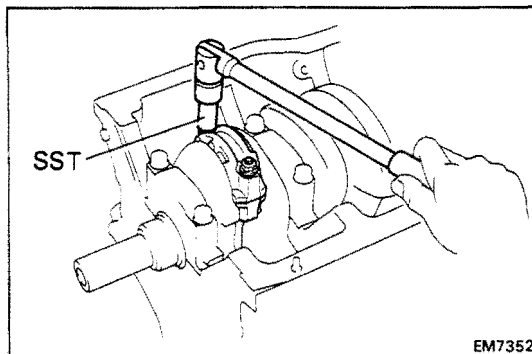

EM7352

(b) Using SST, remove the connecting rod cap nuts.  
SST 09011-38121

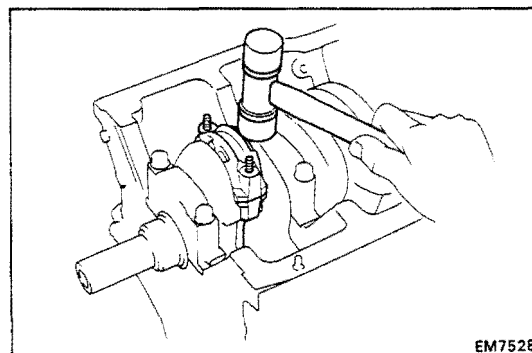

EM7528

(c) Using a plastic-faced hammer, lightly tap the connecting rod bolts and lift off the connecting rod cap.

**HINT:** Keep the lower bearing inserted with the connecting cap.

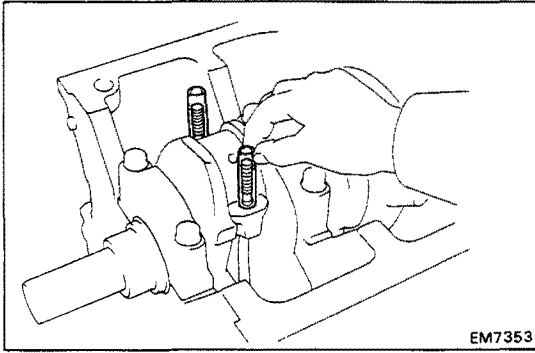

- (d) Cover the connecting rod bolts with a short piece of hose to protect the crankshaft from damage.

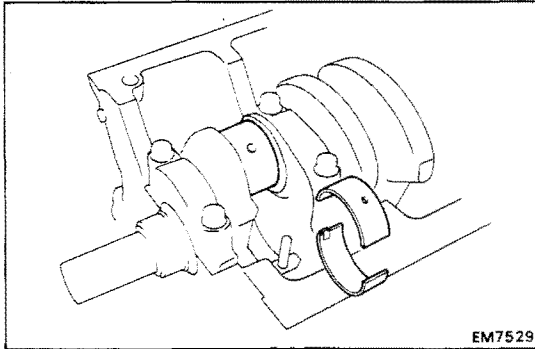

- (e) Clean crank pin and bearing.  
 (f) Check the crank pin and bearing for pitting and scratches.

If the crank pin or bearing is damaged, replace the bearings. If necessary, grind or replace the crankshaft.

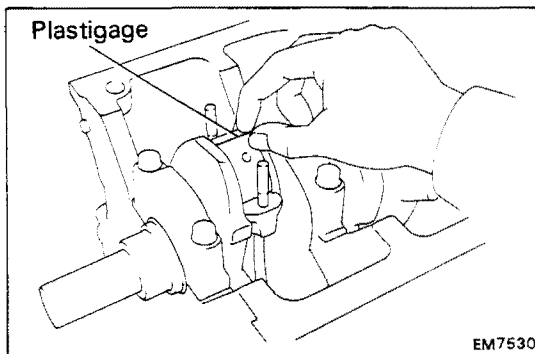

- (g) Lay a strip of Plastigage across the crank pin.

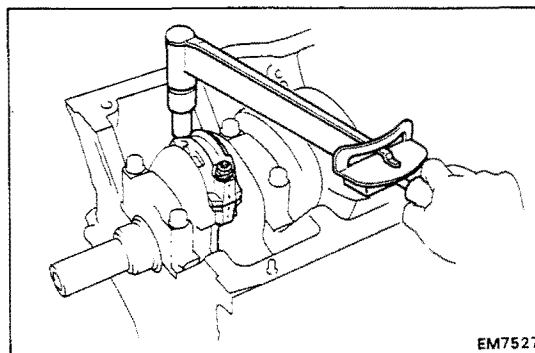

- (h) Install the connecting rod cap.  
 (See step 6 on pages EM-171 and 172)

**Torque:** 1st 250 kg-cm (18 ft-lb, 25 N·m)  
 2nd Turn 90°

**NOTICE:** Do not turn the crankshaft.

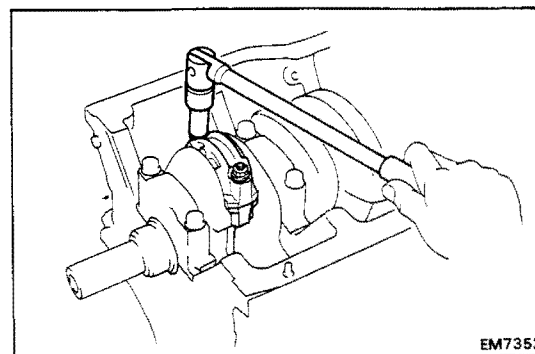

- (i) Remove the connecting rod cap.  
 (See procedures (b) and (c) above)

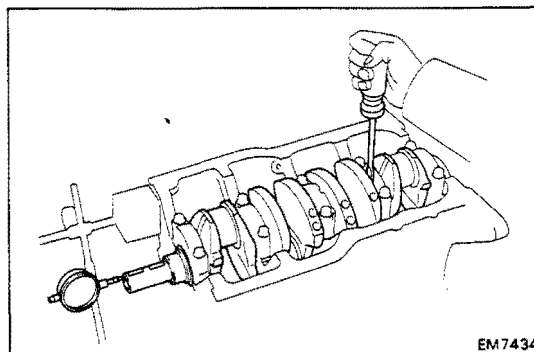
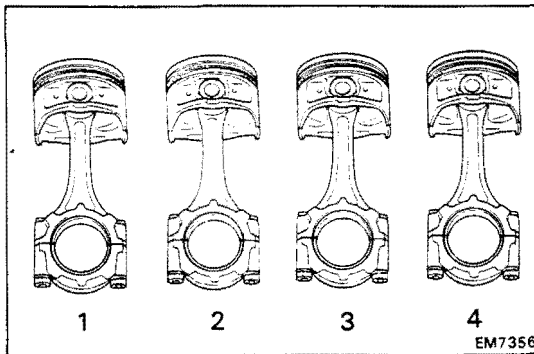
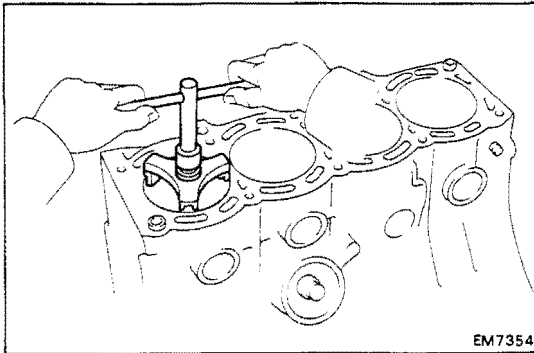
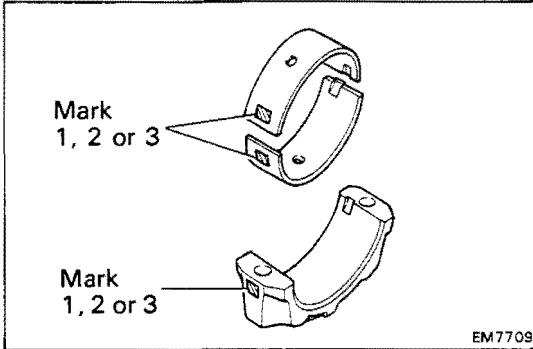
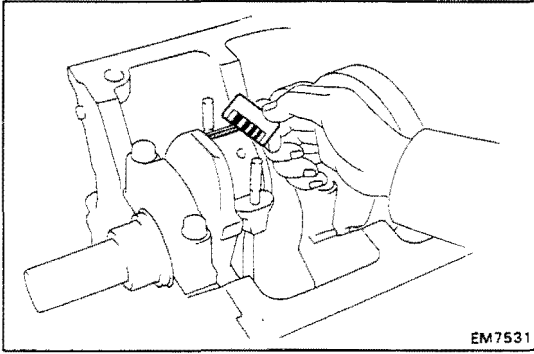

(j) Measure the Plastigage at its widest point.

**Standard oil clearance:**

<b>STD</b>	<b>0.024 – 0.055 mm</b> <b>(0.0009 – 0.0022 in.)</b>
<b>U/S 0.25</b>	<b>0.023 – 0.069 mm</b> <b>(0.0009 – 0.0027 in.)</b>

**Maximum oil clearance: 0.08 mm (0.0031 in.)**

If the oil clearance is greater than maximum, replace the bearings. If necessary, grind or replace the crankshaft.

**HINT:** If using a standard bearing, replace it with one having the same number marked on the connecting rod cap. There are three sizes of standard bearings, marked "1", "2" and "3" accordingly.

**Standard sized bearing center wall thickness:**

<b>Mark "1"</b>	<b>1.484 – 1.488 mm</b> <b>(0.0584 – 0.0586 in.)</b>
<b>Mark "2"</b>	<b>1.488 – 1.492 mm</b> <b>(0.0586 – 0.0587 in.)</b>
<b>Mark "3"</b>	<b>1.492 – 1.496 mm</b> <b>(0.0587 – 0.0589 in.)</b>

(k) Completely remove the Plastigage.

#### 4. REMOVE PISTON AND CONNECTING ROD ASSEMBLIES

- Using a ridge reamer, remove all the carbon from the top of the cylinder.
- Cover the connecting rod bolts.  
(See page EM-151)
- Push the piston, connecting rod assembly and upper bearing through the top of the cylinder block.

**HINT:**

- Keep the bearings, connecting rod and cap together.
- Arrange the piston and connecting rod assemblies in correct order.

#### 5. CHECK CRANKSHAFT THRUST CLEARANCE

Using a dial indicator, measure the thrust clearance while prying the crankshaft back and forth with a screwdriver.

**Standard thrust clearance: 0.020 – 0.220 mm**  
**(0.0008 – 0.0087 in.)**

**Maximum thrust clearance: 0.30 mm (0.0118 in.)**

If the thrust clearance is greater than maximum, replace the thrust washers as a set.

**Thrust washer thickness: 2.440 – 2.490 mm**  
**(0.0961 – 0.0980 in.)**

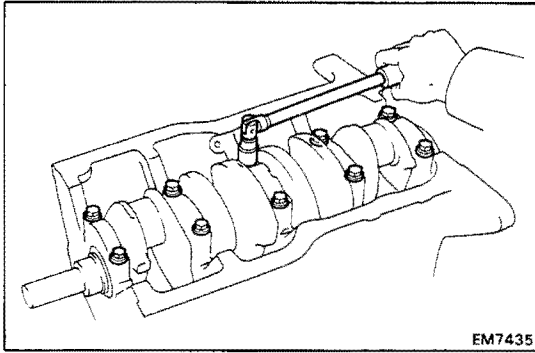

EM7435

## 6. REMOVE MAIN BEARING CAPS AND CHECK OIL CLEARANCE

- (a) Remove the main bearing cap bolts.

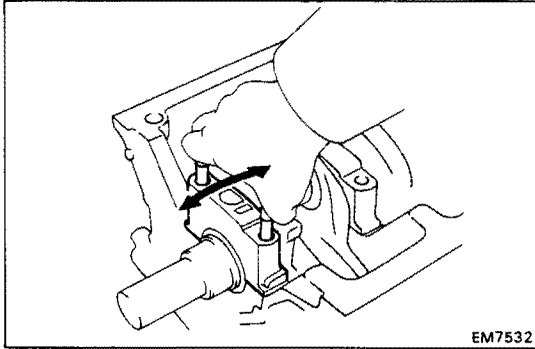

EM7532

- (b) Using the removed main bearing cap bolts, pry the main bearing cap back and forth, and remove the main bearing caps, lower bearings and lower thrust washers (No.3 main bearing cap only).

### HINT:

- Keep the lower bearing and main bearing cap together.
- Arrange the main bearing caps and lower thrust washers in correct order.

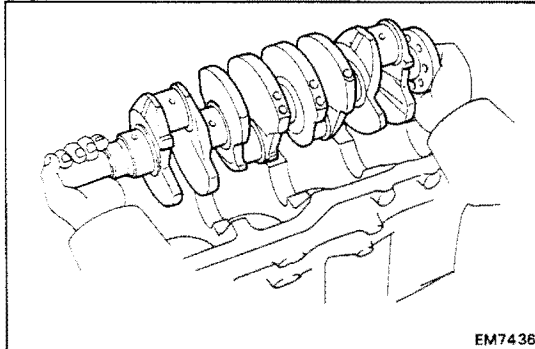

EM7436

- (c) Lift out the crankshaft.

HINT: Keep the upper bearing and upper thrust washers together with the cylinder block.

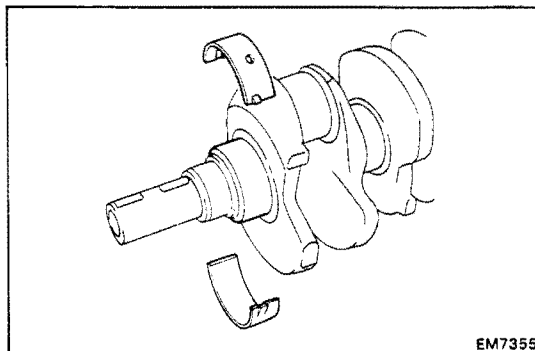

EM7355

- (d) Clean each main journal and bearing.

- (e) Check each main journal and bearing for pitting and scratches.

If the journal or bearing is damaged, replace the bearings. If necessary, grind or replace the crankshaft.

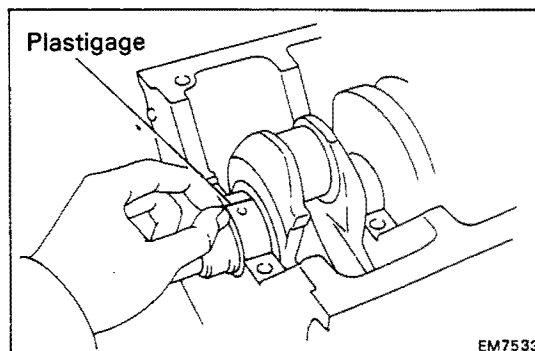

EM7533

- (f) Place the crankshaft on the cylinder block.

- (g) Lay a strip of Plastigage across each journal.

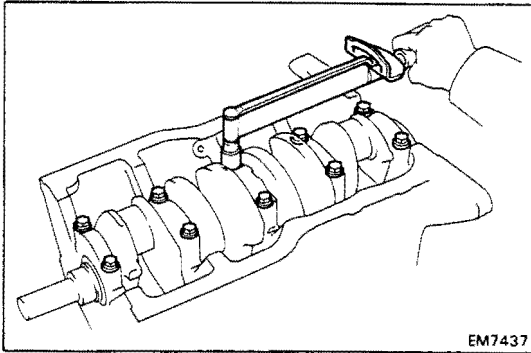

EM7437

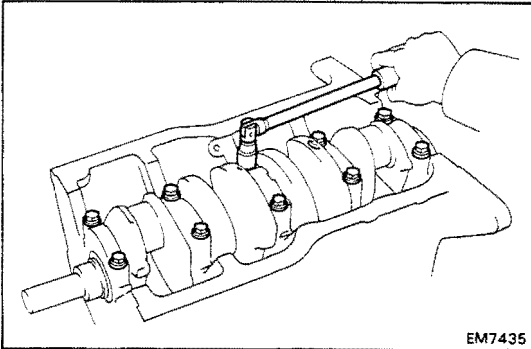

EM7435

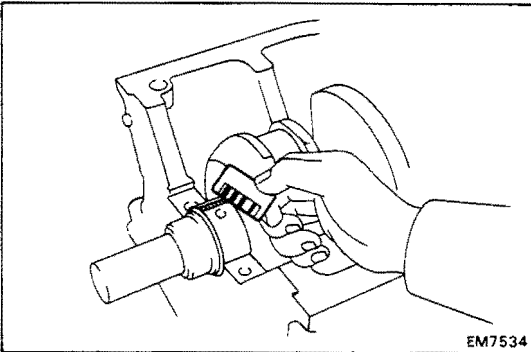

EM7534

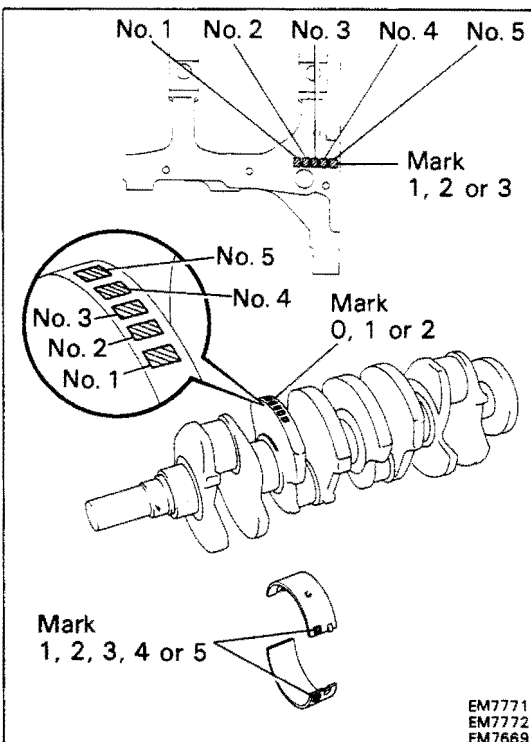
EM7771  
EM7772  
EM7669

- (h) Install the main bearing caps.  
(See step 4 on page EM-170)

**Torque: 600 kg-cm (43 ft-lb, 59 N·m)**

**NOTICE: Do not turn the crankshaft.**

- (i) Remove the main bearing caps.  
(See procedures (a) and (b) above)

- (j) Measure the Plastigage at its widest point.

**Standard clearance:**

<b>No.3</b>	<b>STD</b>	<b>0.025 – 0.044 mm</b> (0.0010 – 0.0017 in.)
	<b>U/S 0.25</b>	<b>0.027 – 0.067 mm</b> (0.0011 – 0.0026 in.)
<b>Others</b>	<b>STD</b>	<b>0.015 – 0.034 mm</b> (0.0006 – 0.0013 in.)
	<b>U/S 0.25</b>	<b>0.019 – 0.059 mm</b> (0.0007 – 0.0023 in.)

**Maximum clearance: 0.08 mm (0.0031 in.)**

**HINT:** If replacing the cylinder block subassembly, the bearing standard clearance will be:

<b>No.3</b>	<b>0.027 – 0.054 mm</b> (0.0011 – 0.0021 in.)
<b>Others</b>	<b>0.017 – 0.044 mm</b> (0.0007 – 0.0017 in.)

If the oil clearance is greater than maximum, replace the bearings. If necessary, grind or replace the crankshaft.

**HINT:** If using a standard bearing, replace it with one having the same number. If the number of the bearing cannot be determined, select the correct bearing by adding together the numbers imprinted on the cylinder block and crankshaft, then select the bearing with the same number as the total. There are five sizes of standard bearings, marked "1," "2," "3," "4" and "5" accordingly.

	Number marked								
	Cylinder block			Crankshaft			Bearing		
Cylinder block	1	2	3	0	1	2	0	1	2
Crankshaft	0	1	2	0	1	2	0	1	2
Bearing	1	2	3	2	3	4	3	4	5

**EXAMPLE:** Cylinder block "2" + Crankshaft "1"  
= Bearing "3"

**(Reference)****Cylinder block main journal bore diameter:**

Mark "1"	59.020 – 59.026 mm (2.3236 – 2.3239 in.)
Mark "2"	59.026 – 59.032 mm (2.3239 – 2.3241 in.)
Mark "3"	59.032 – 59.038 mm (2.3241 – 2.3243 in.)

**Crankshaft journal diameter:**

Mark "0"	54.998 – 55.003 mm (2.1653 – 2.1655 in.)
Mark "1"	54.993 – 54.998 mm (2.1651 – 2.1653 in.)
Mark "2"	54.988 – 54.993 mm (2.1649 – 2.1651 in.)

**Standard sized bearing center wall thickness:**

No.3	Mark "1"	1.992 – 1.995 mm (0.0784 – 0.0785 in.)
	Mark "2"	1.995 – 1.998 mm (0.0785 – 0.0787 in.)
	Mark "3"	1.998 – 2.001 mm (0.0787 – 0.0788 in.)
	Mark "4"	2.001 – 2.004 mm (0.0788 – 0.0789 in.)
	Mark "5"	2.004 – 2.007 mm (0.0789 – 0.0790 in.)
Others	Mark "1"	1.997 – 2.000 mm (0.0786 – 0.0787 in.)
	Mark "2"	2.000 – 2.003 mm (0.0787 – 0.0789 in.)
	Mark "3"	2.003 – 2.006 mm (0.0789 – 0.0790 in.)
	Mark "4"	2.006 – 2.009 mm (0.0790 – 0.0791 in.)
	Mark "5"	2.009 – 2.012 mm (0.0791 – 0.0792 in.)

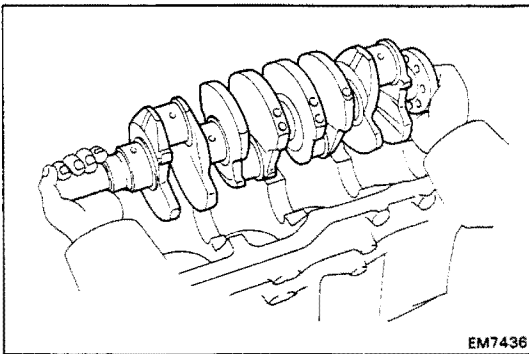

(k) Completely remove the Plastigage.

**7. REMOVE CRANKSHAFT**

- (a) Lift out the crankshaft.
- (b) Remove the upper bearings and upper thrust washers from cylinder block.

**HINT:** Arrange the main bearing caps, bearings and thrust washers in correct order.

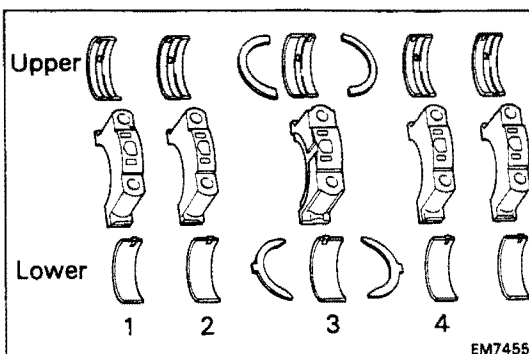

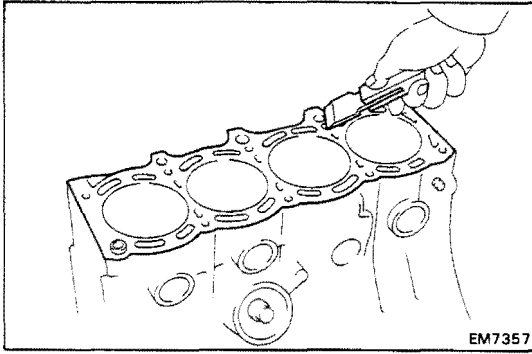

## INSPECTION OF CYLINDER BLOCK

### 1. CLEAN CYLINDER BLOCK

#### A. Remove gasket material

Using a gasket scraper, remove all the gasket material from the top surface of the cylinder block.

#### B. Clean cylinder block

Using a soft brush and solvent, thoroughly clean the cylinder block.

### 2. INSPECT TOP SURFACE OF CYLINDER BLOCK FOR FLATNESS

Using a precision straight edge and feeler gauge, measure the surfaces contacting the cylinder head gasket for warpage.

**Maximum warpage: 0.05 mm (0.0020 in.)**

If warpage is greater than maximum, replace the cylinder block.

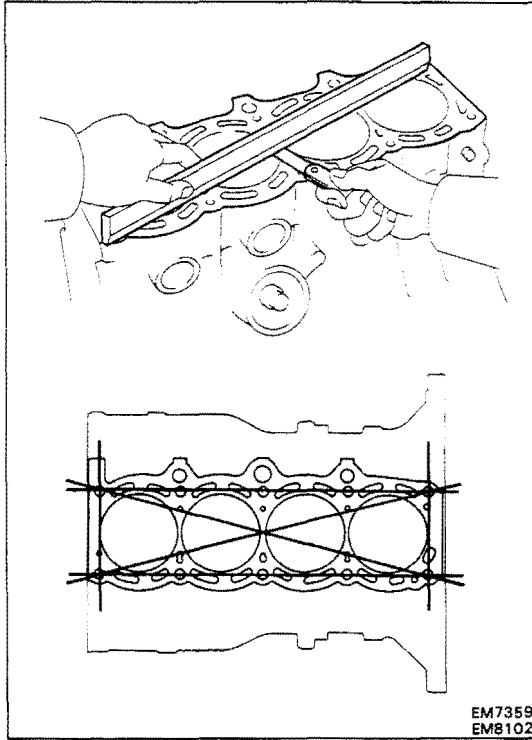

### 3. INSPECT CYLINDER FOR VERTICAL SCRATCHES

Visually check the cylinder for vertical scratches.

If deep scratches are present, replace the cylinder block.

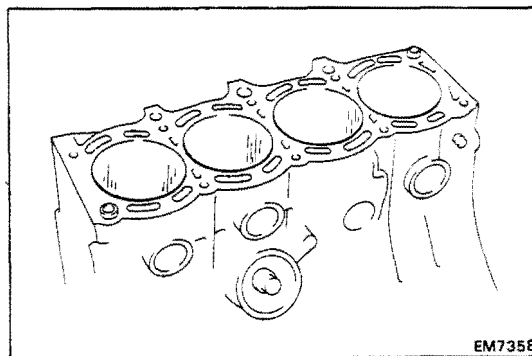

### 4. INSPECT CYLINDER BORE DIAMETER

**HINT:** There are three sizes of the standard cylinder bore diameter, marked "1", "2" and "3" accordingly. The mark is stamped on the top of the cylinder block.

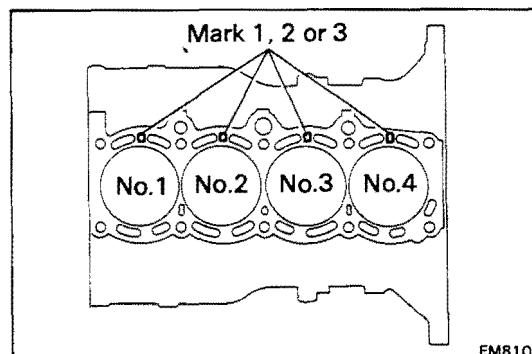

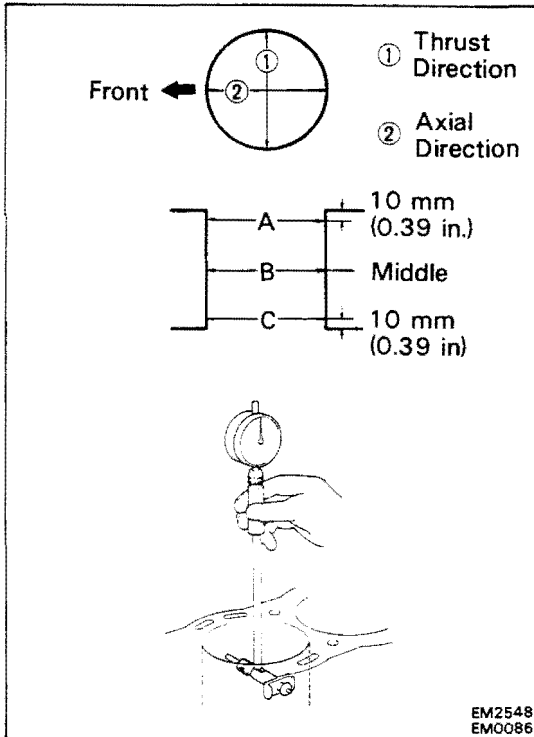

Using a cylinder gauge, measure the cylinder bore diameter at positions A, B and C in the thrust axial directions.

**Standard diameter:**

**Mark "1"** 87.000 – 87.010 mm  
(3.4252 – 3.4256 in.)

**Mark "2"** 87.010 – 87.020 mm  
(3.4256 – 3.4260 in.)

**Mark "3"** 87.020 – 87.030 mm  
(3.4260 – 3.4264 in.)

**Maximum diameter:** 87.23 mm (3.4342 in.)

If the diameter is greater than maximum, replace the cylinder block.

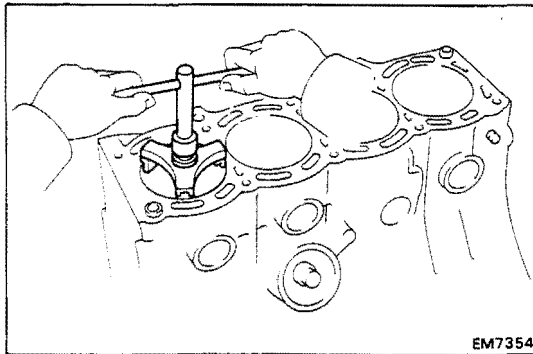

## 5. REMOVE CYLINDER RIDGE

If the wear is less than 0.2 mm (0.008 in.), using a ridge reamer, grind the top of the cylinder.

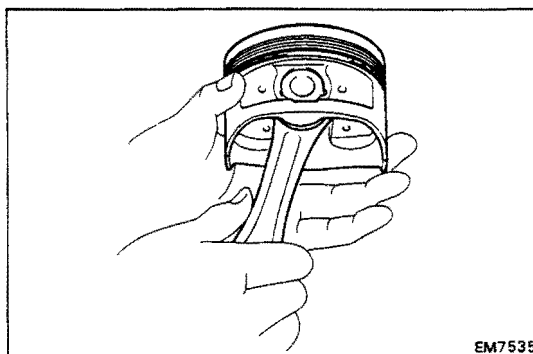

## DISASSEMBLY OF PISTON AND CONNECTING ROD ASSEMBLIES

### 1. CHECK FIT BETWEEN PISTON AND PISTON PIN

Try to move the piston back and forth on the piston pin. If any movement is felt, replace the piston and pin as a set.

### 2. REMOVE PISTON RINGS

(a) Using a piston ring expander, remove the two compression rings.

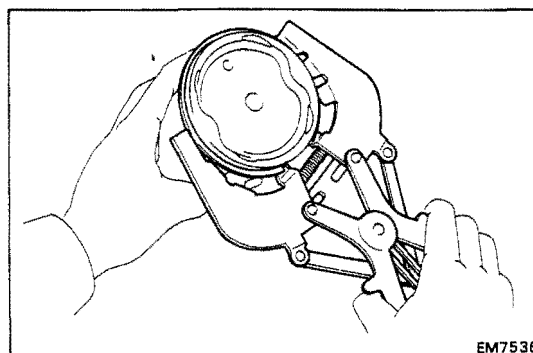



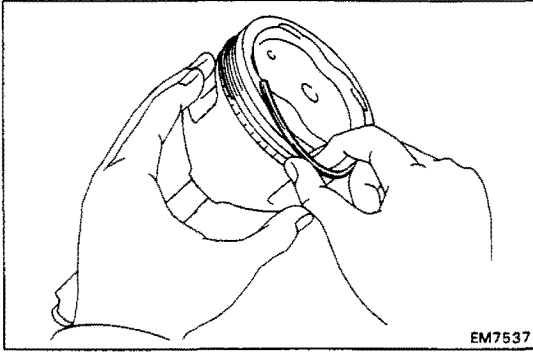

- (b) Remove the two side rails and oil ring expander by hand.

HINT: Arrange the rings in correct order only.

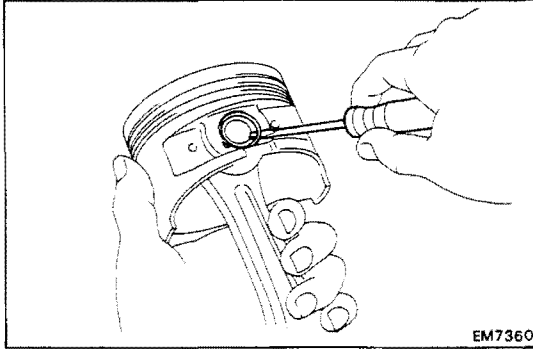

### 3. DISCONNECT CONNECTING ROD FROM PISTON

- (a) Using a small screwdriver, pry out the two snap rings.

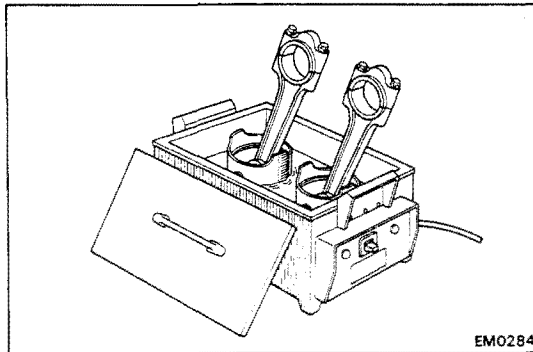

- (b) Gradually heat the piston to 80 – 90°C (176 – 194°F).

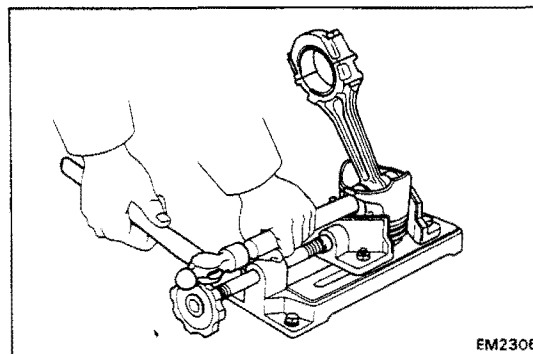

- (c) Using plastic-faced hammer and brass bar, lightly tap out the piston pin and remove the connecting rod.

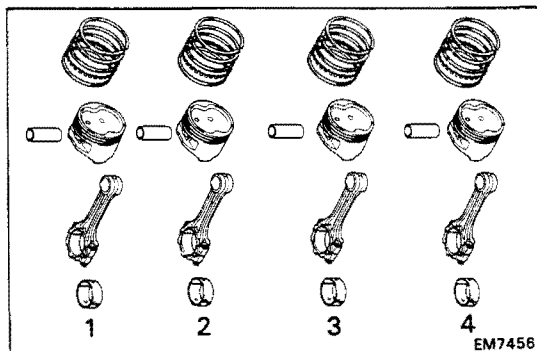

#### HINT:

- The piston and pin are a matched set.
- Arrange the pistons, pins, rings, connecting rods and bearings in correct order.

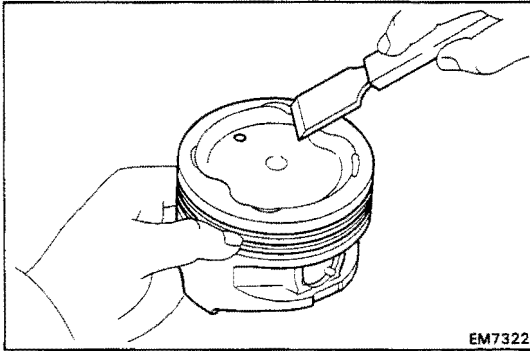

EM7322

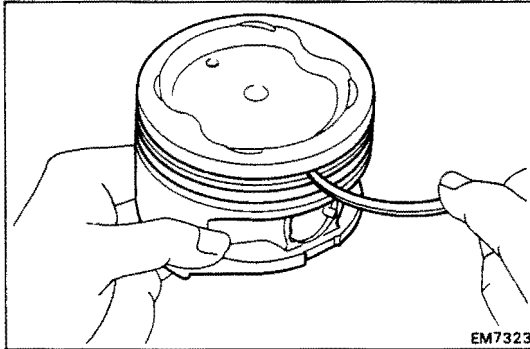

EM7323

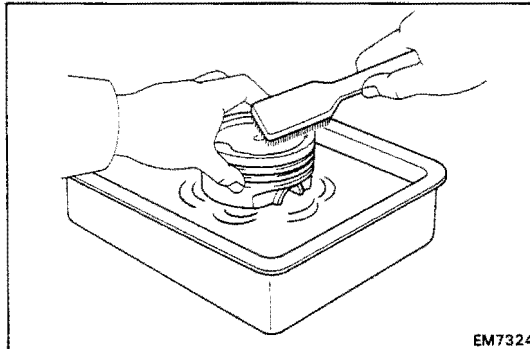

EM7324

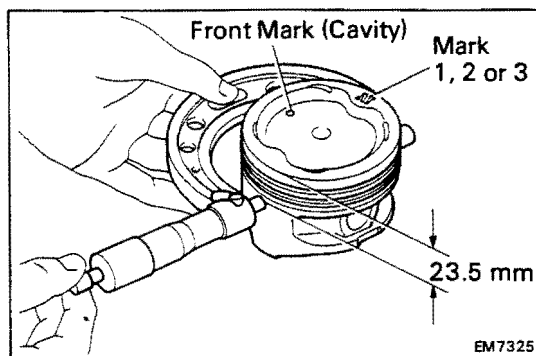

EM7325

## INSPECTION OF PISTON AND CONNECTING ROD ASSEMBLIES

### 1. CLEAN PISTON

(a) Using a gasket scraper, remove the carbon from the piston top.

(b) Using a groove cleaning or broken ring, clean the piston ring grooves.

(c) Using solvent and a brush, thoroughly clean the piston.

**NOTICE:** Do not use a wire brush.

### 2. INSPECT PISTON

#### A. Inspect piston oil clearance

**HINT:** There are three sizes of the standard piston diameter, marked "1", "2" and "3" accordingly. The mark is stamped on the piston top.

(a) Using a micrometer, measure the piston diameter at right angles to the piston pin center line, 23.5 mm (0.925 in.) from the piston head.

**Piston diameter:**

**Mark "1"** 86.911 – 86.921 mm  
(3.4217 – 3.4221 in.)

**Mark "2"** 86.921 – 86.931 mm  
(3.4221 – 3.4225 in.)

**Mark "3"** 86.931 – 86.941 mm  
(3.4225 – 3.4229 in.)

- (b) Measure the cylinder bore diameter in the thrust directions.

(See step 4 on page EM-157)

- (c) Subtract the piston diameter measurement from the minimum cylinder bore diameter measurement.

**Standard oil clearance: 0.079 – 0.099 mm  
(0.0031 – 0.0039 in.)**

**Maximum oil clearance: 0.119 mm (0.0047 in.)**

If the oil clearance is greater than maximum, replace all the four pistons. If necessary, replace the cylinder block.

**HINT (Use new cylinder block):** Use a piston with the same number mark as the cylinder bore diameter marked on the cylinder block.

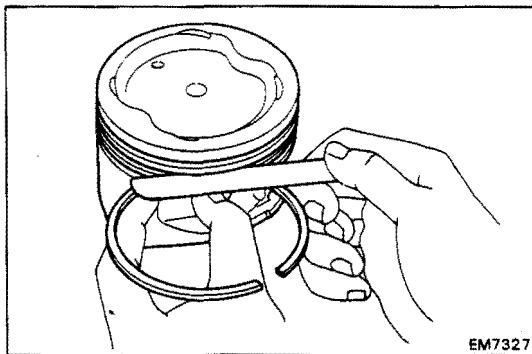
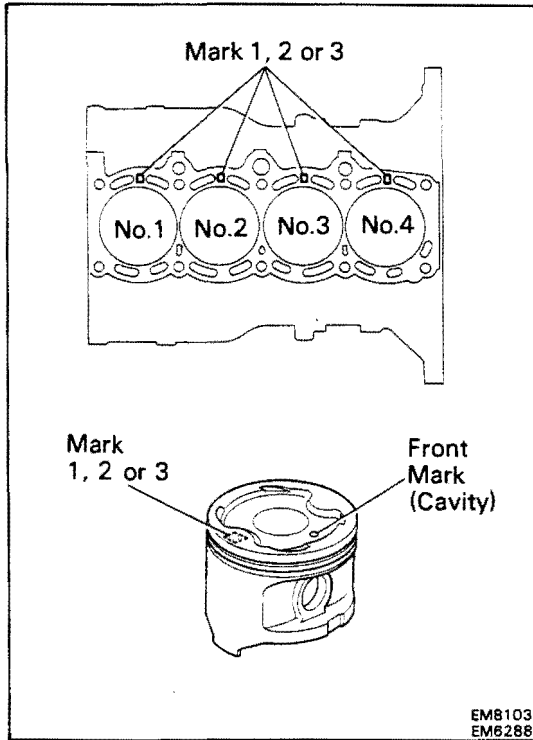

### B. Inspect piston ring groove clearance

Using a feeler gauge, measure the clearance between new piston ring and the wall of the piston ring groove.

**Ring groove clearance: 0.030 – 0.070 mm  
(0.0012 – 0.0028 in.)**

If the clearance is greater than maximum, replace the piston.

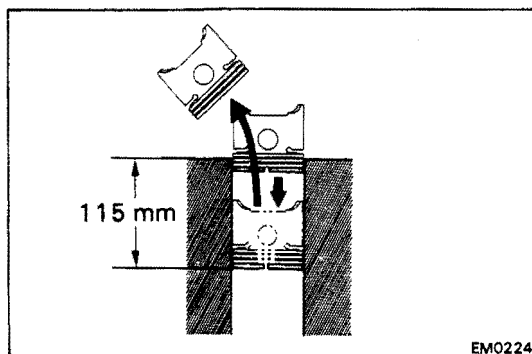

### C. Inspect piston ring end gap

- (a) Insert the piston ring into the cylinder bore.

- (b) Using a piston, push the piston ring a little beyond the bottom of the ring travel, 115 mm (4.53 in.) from the top of the cylinder block.

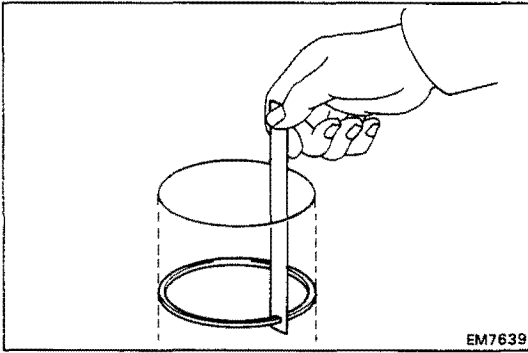

EM7639

(c) Using a feeler gauge, measure the end gap.

**Standard end gap:**

No.1	0.270 – 0.500 mm (0.0106 – 0.0197 in.)
No.2	0.350 – 0.600 mm (0.0138 – 0.0234 in.)
Oil (Side rail)	0.200 – 0.550 mm (0.0079 – 0.0217 in.)

**Maximum end gap:**

No.1	1.10 mm (0.0433 in.)
No.2	1.20 mm (0.0472 in.)
Oil (Side rail)	1.15 mm (0.0453 in.)

If the end gap is greater than maximum, replace the piston ring. If the end gap is greater than maximum, even with a new piston ring, replace the cylinder block.

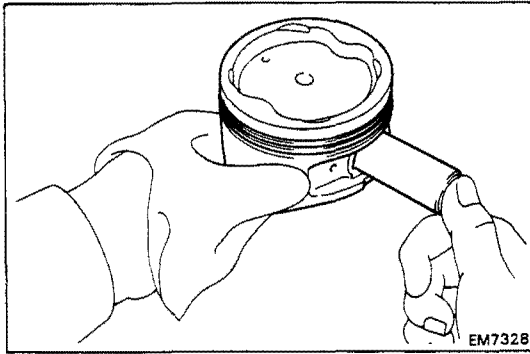

EM7328

**D. Inspect piston pin fit**

At 60°C (140°F), you should be able to push the piston pin into the piston pin hole with your thumb.

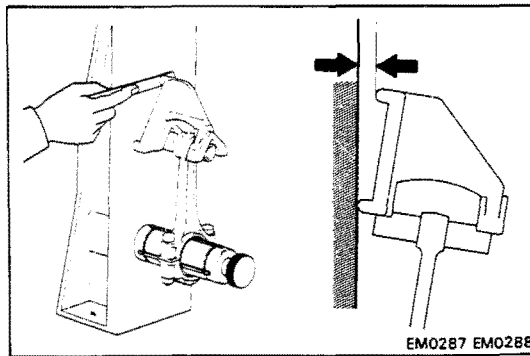

EM0287 EM0288

**3. INSPECT CONNECTING ROD**

**A. Inspect connecting rod alignment**

Using rod aligner and feeler gauge, check the connecting rod alignment.

- Check for bending.

**Maximum bending:**

0.05 mm (0.0020 in.) per 100 mm (3.94 in.)

If bend is greater than maximum, replace the connecting rod assembly.

- Check for twist.

**Maximum twist:**

0.15 mm (0.0059 in.) per 100 mm (3.94 in.)

If twist is greater than maximum, replace the connecting rod assembly.

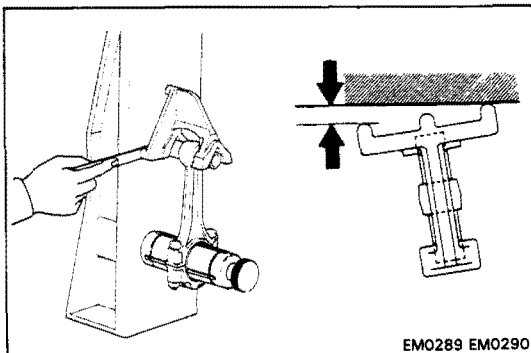

EM0289 EM0290

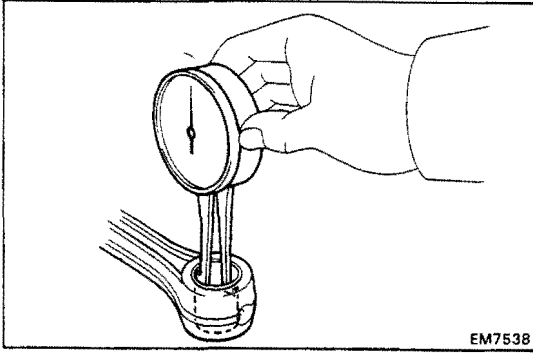

### B. Inspect piston pin oil clearance

- (a) Using a caliper gauge, measure the inside diameter of the connecting rod bushing.

**Bushing inside diameter: 22.005 – 22.017 mm  
(0.8663 – 0.8668 in.)**

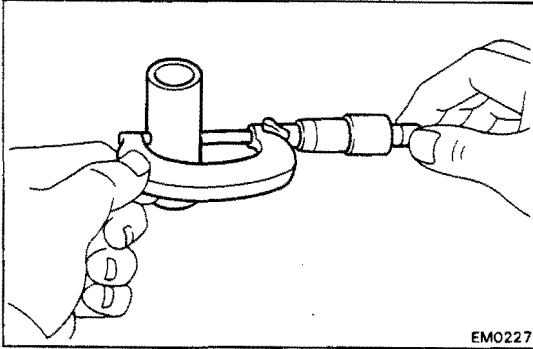

- (b) Using a micrometer, measure the piston pin diameter.

**Piston pin diameter: 21.997 – 22.009 mm  
(0.8660 – 0.8665 in.)**

- (c) Subtract the piston pin diameter measurement from the bushing inside diameter measurement.

**Standard oil clearance: 0.005 – 0.011 mm  
(0.0002 – 0.0004 in.)**

**Maximum oil clearance: 0.05 mm (0.0020 in.)**

If the oil clearance is greater than maximum, replace the bushing. If necessary, replace the piston and piston pin as a set.

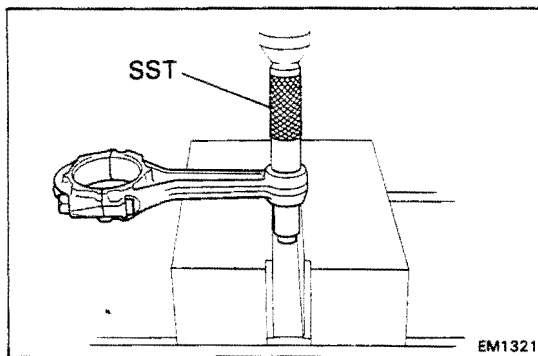

### C. If necessary, replace connecting rod bushing

- (a) Using SST and a press, press out the bushing.  
SST 09222-30010

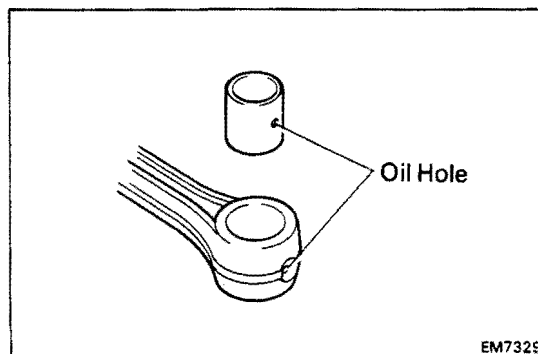

- (b) Align the oil holes of a new bushing and the connecting rod.

- (c) Using SST and a press, press in the bushing.  
SST 09222-30010

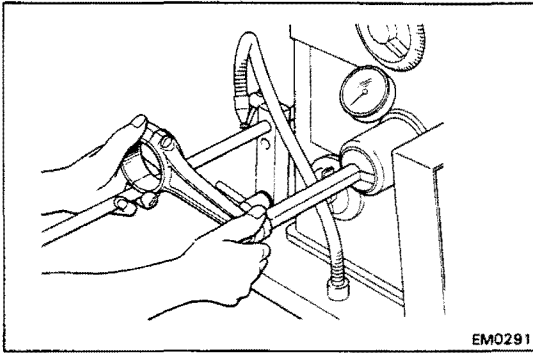

- (d) Using a pin hole grinder, hone the bushing to obtain the standard specified clearance (see step B above) between the bushing and piston pin.

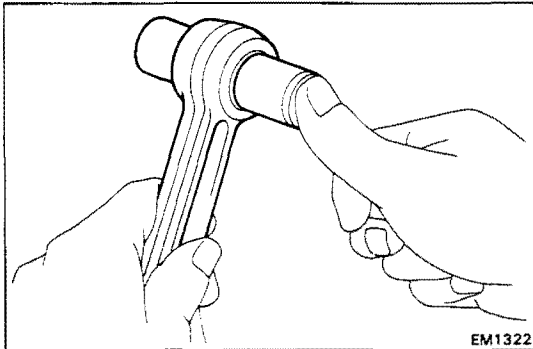

- (e) Check the piston pin fit at normal room temperature. Coat the piston pin with engine oil, and push it into the connecting rod with your thumb.

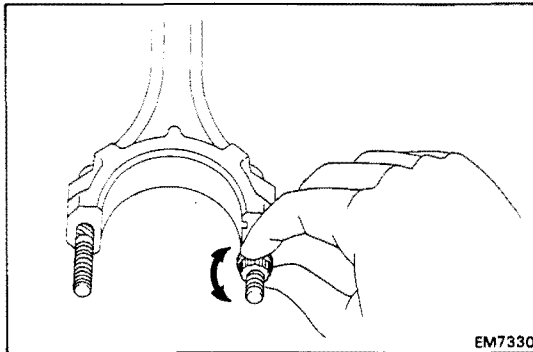

#### D. Inspect connecting rod bolts

- (a) Install the cap nut to the connecting rod bolt. Check that the cap nut can be turned easily by hand to the end of the thread.

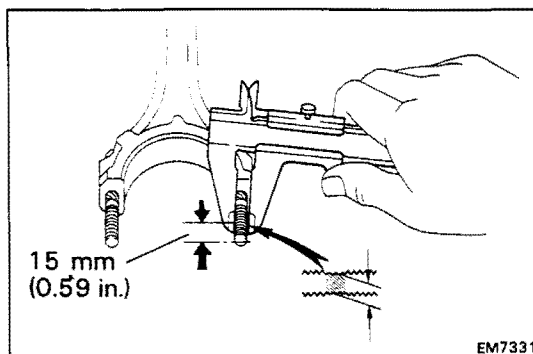

- (b) If the cap nut cannot be turned easily, measure the outside diameter of the connecting rod bolt.

**Standard diameter:** 7.860 – 8.000 mm  
(0.3094 – 0.3150 in.)

**Minimum diameter:** 7.60 mm (0.2992 in.)

**HINT:** If the location of this area cannot be judged by visual inspection, measure the outer diameter at the location shown in the illustration.

If the outside diameter is less than minimum, replace the connecting rod bolt and cap nut as a set.

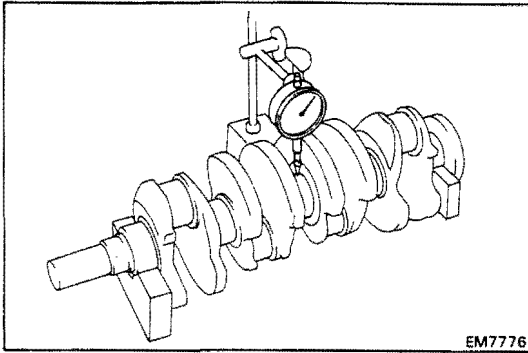

## INSPECTION AND REPAIR OF CRANKSHAFT

### 1. INSPECT CRANKSHAFT FOR RUNOUT

- (a) Place the crankshaft on V-blocks.
- (b) Using a dial indicator, measure the circle runout at the center journal.

**Maximum circle runout: 0.06 mm (0.0024 in.)**

If the circle runout is greater than maximum, replace the crankshaft.

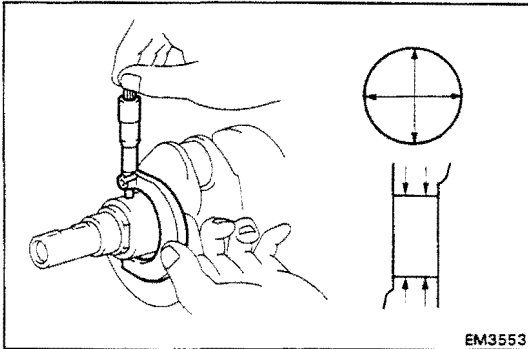

### 2. INSPECT MAIN JOURNALS AND CRANK PINS

- (a) Using a micrometer, measure the diameter of each main journal and crank pin.

**Main journal diameter:**

<b>STD</b>	<b>54.988 – 55.003 mm</b> <b>(2.1653 – 2.1655 in.)</b>
<b>U/S 0.25</b>	<b>54.745 – 54.755 mm</b> <b>(2.1553 – 2.1557 in.)</b>

**Crank pin diameter:**

<b>STD</b>	<b>51.985 – 52.000 mm</b> <b>(2.0466 – 2.0472 in.)</b>
<b>U/S 0.25</b>	<b>51.745 – 51.755 mm</b> <b>(2.0372 – 2.0376 in.)</b>

If the diameter is not as specified, check the oil clearance (See pages EM-150 to 154). If necessary, grind or replace the crankshaft.

- (b) Check each main journal and crank pin for taper and out-of-round as shown.

**Maximum taper and out-of-round: 0.02 mm**  
**(0.0008 in.)**

If the taper and out-of-round is greater than maximum, replace the crankshaft.

### 3. IF NECESSARY, GRIND AND HONE MAIN JOURNALS AND/OR CRANK PINS

Grind and hone the main journals and/or crank pins to the finished undersized diameter (See procedure step 2).

Install new main journal and/or crank pin undersized bearings.

**REPLACEMENT OF CRANKSHAFT OIL SEALS**

**HINT:** There are two methods (A and B) to replace the oil seal which are as follows:

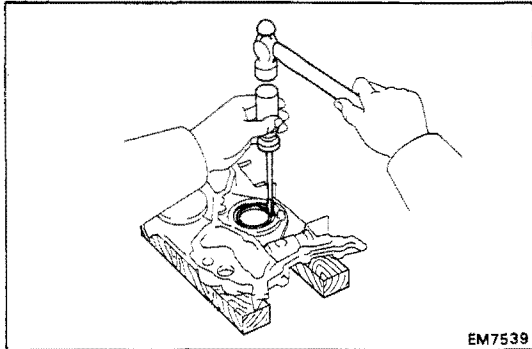
**1. REPLACE CRANKSHAFT FRONT OIL SEAL****A. If oil pump is removed from cylinder block:**

(a) Using screwdriver and hammer, tap out the oil seal.

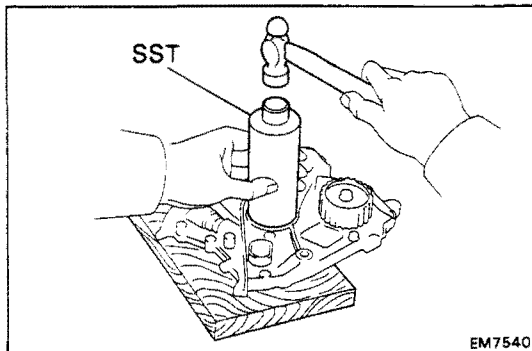

(b) Using SST and a hammer, tap in a new oil seal until its surface is flush with the oil pump case edge.

SST 09226-10010

(c) Apply MP grease to the oil seal lip.

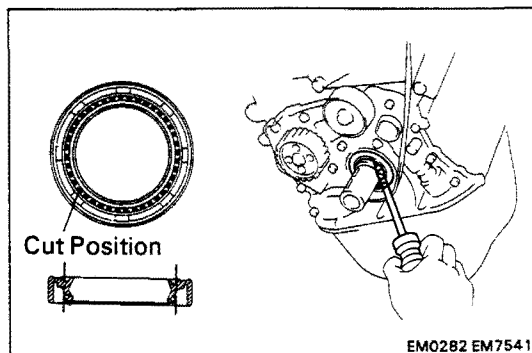
**B. If oil pump is installed to the cylinder block:**

(a) Using a knife, cut off the oil seal lip.

(b) Using a screwdriver, pry out the oil seal.

**NOTICE:** Be careful not to damage the crankshaft. Tape the screwdriver tip.

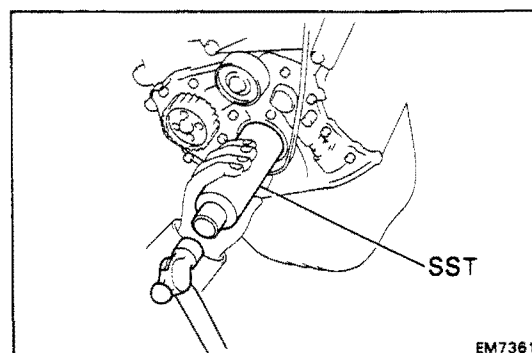

(c) Apply MP grease to a new oil seal lip.

(d) Using SST and a hammer, tap in the oil seal until its surface is flush with the oil pump case edge.

SST 09226-10010



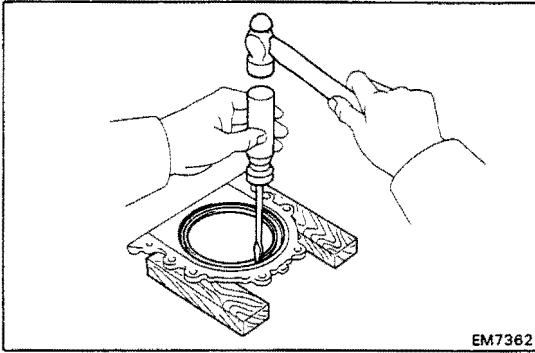

EM7362

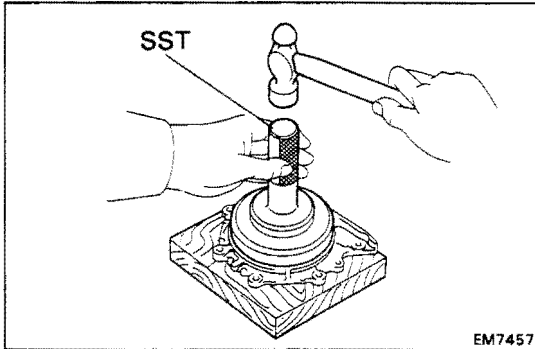

EM7457

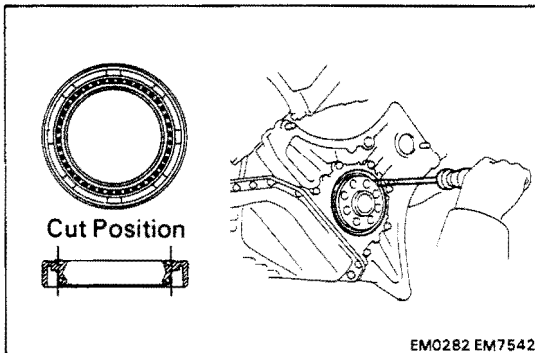

EM0282 EM7542

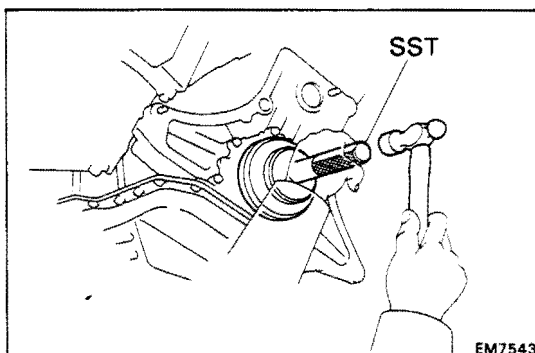

EM7543

## 2. REPLACE CRANKSHAFT REAR OIL SEAL

### A. If rear oil seal retainer is removed from cylinder block:

- (a) Using screwdriver and hammer, tap out the oil seal.

- (b) Using SST and a hammer, tap in a new oil seal until its surface is flush with the rear oil seal edge.

SST 09223-63010

- (c) Apply MP grease to the oil seal lip.

### B. If rear oil seal retainer is installed to cylinder block:

- (a) Using a knife, cut off the oil seal lip.

- (b) Using a screwdriver, pry out the oil seal.

**NOTICE:** Be careful not to damage the crankshaft. Tape the screwdriver tip.

- (c) Apply MP grease to a new oil seal lip.

- (d) Using SST and a hammer, tap in the oil seal until its surface is flush with the rear oil seal retainer edge.

SST 09223-63010

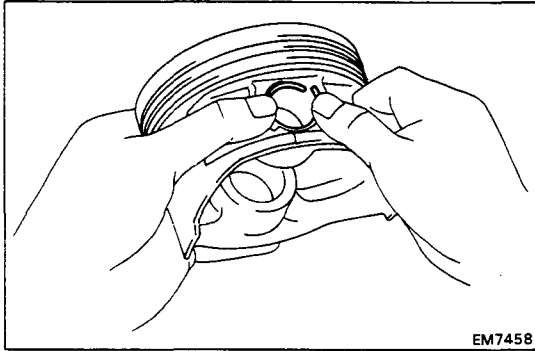

EM7458

## ASSEMBLY OF PISTON AND CONNECTING ROD ASSEMBLIES

### 1. ASSEMBLE PISTON AND CONNECTING ROD

- (a) Install a new snap ring on one side of the piston pin hole.

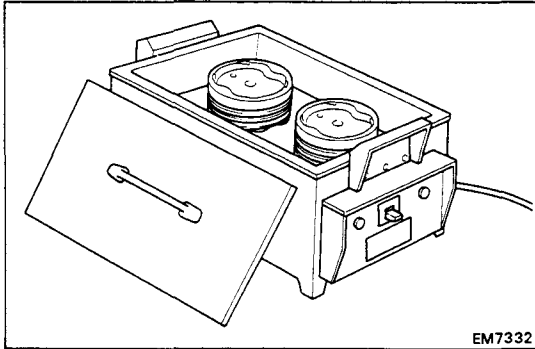

EM7332

- (b) Gradually heat the piston to 80 – 90°C (176 – 194°F).

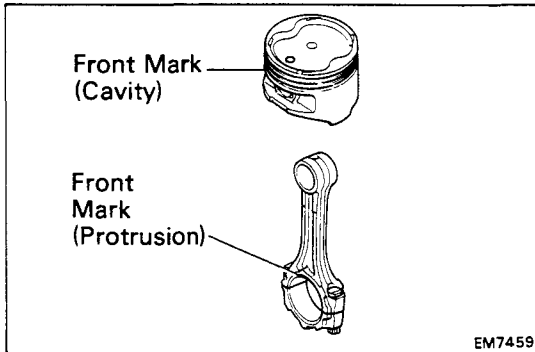

EM7459

- (c) Coat the piston pin with engine oil.  
 (d) Align the front marks of the piston and connecting rod, and push in the piston pin with your thumb.

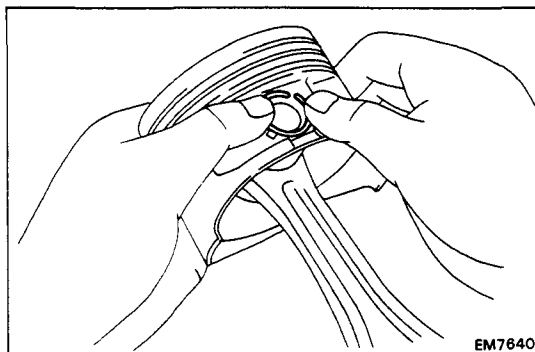

EM7640

- (e) Install a new snap ring on the other side of the piston pin hole.

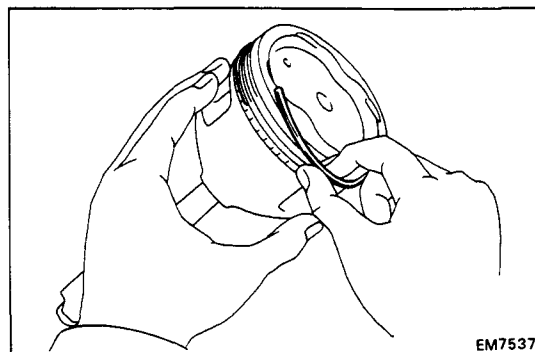

EM7537

### 2. INSTALL PISTON RINGS

- (a) Install the oil ring expander and two side rails by hand.

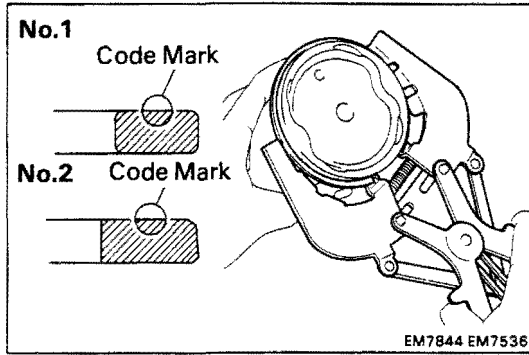

- (b) Using a piston ring expander, install the two compression rings with the code mark facing upward.

Code mark: **No.1 1N or T**  
**No.2 2N or 2T**

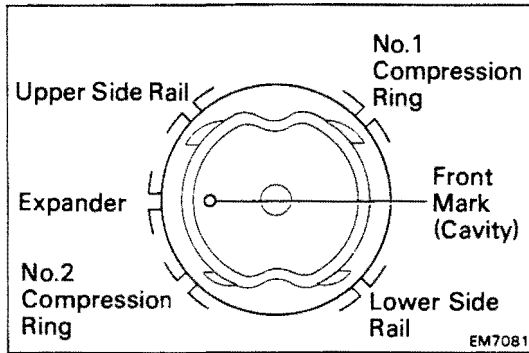

- (c) Position the piston rings so that the ring ends are as shown.

**NOTICE: Do not align the ring ends.**

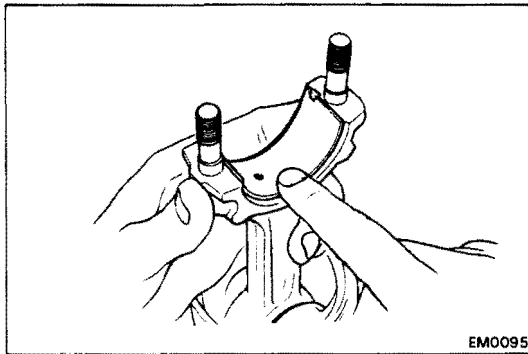

### 3. INSTALL BEARINGS

- (a) Align the bearing claw with the groove of the connecting rod or connecting cap.
- (b) Install the bearings in the connecting rod and connecting rod cap.

## ASSEMBLY OF CYLINDER BLOCK

(See page EM-148)

### HINT:

- Thoroughly clean all parts to be assembled.
- Before installing the parts, apply new engine oil to all sliding and rotating surfaces.
- Replace all gaskets, O-rings and oil seals with new parts.

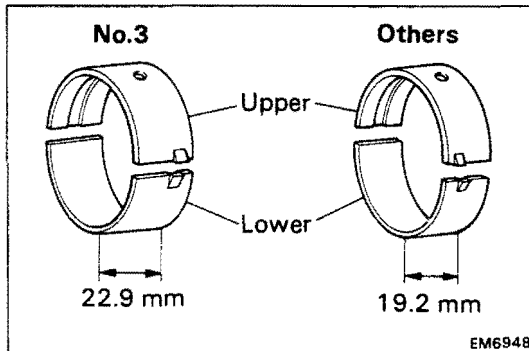

### 1. INSTALL MAIN BEARINGS

#### HINT:

- Main bearings come in widths of 19.2 mm (0.756 in.) and 22.9 mm (0.902 in.). Install the 22.9 mm (0.902 in.) bearings in the No.3 cylinder block journal position with the main bearing cap. Install the 19.2 mm (0.756 in.) bearings in the other positions.
- Upper bearings have an oil groove and oil holes; lower bearings do not.

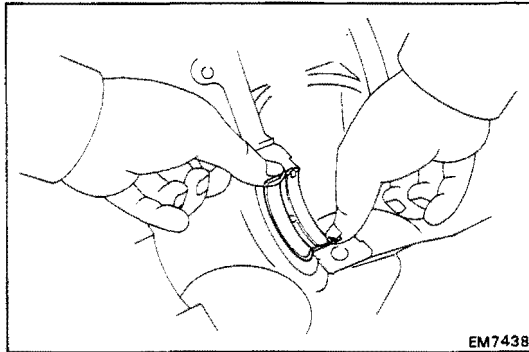

- (a) Align the bearing claw with the claw groove of the cylinder block, and push in the five upper bearings.

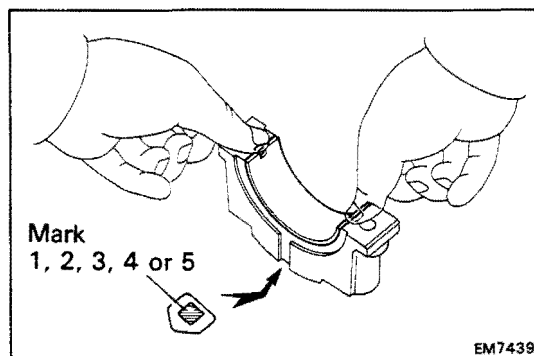

- (b) Align the bearing claw with the claw groove of the main bearing cap, and push in the five lower bearings.

HINT: A number is marked on each main bearing cap to indicate the installation position.

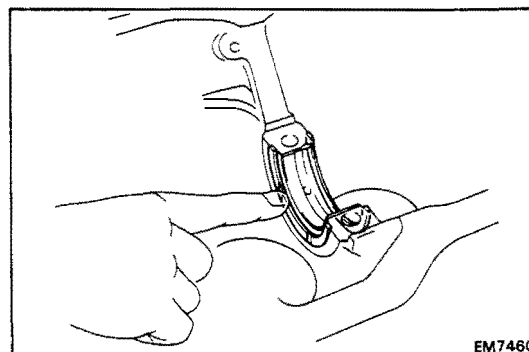

### 2. INSTALL UPPER THRUST WASHERS

Install the two thrust washers under the No.3 journal position of the cylinder block with the oil grooves facing outward.

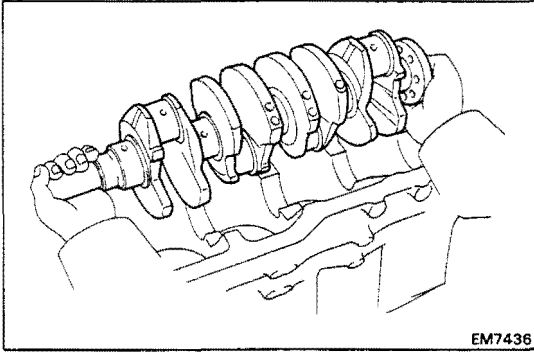

EM7436

### 3. PLACE CRANKSHAFT ON CYLINDER BLOCK

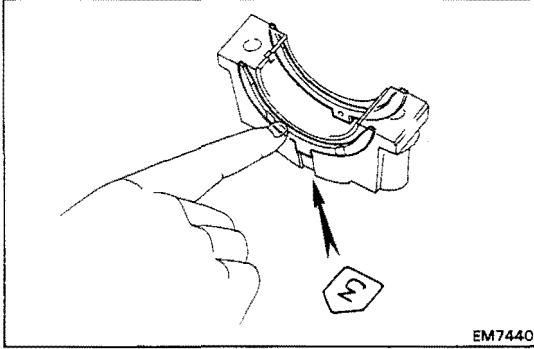

EM7440

### 4. INSTALL MAIN BEARING CAPS AND LOWER THRUST WASHERS

- (a) Install the two thrust washers on the No.3 bearing cap with the grooves facing outward.

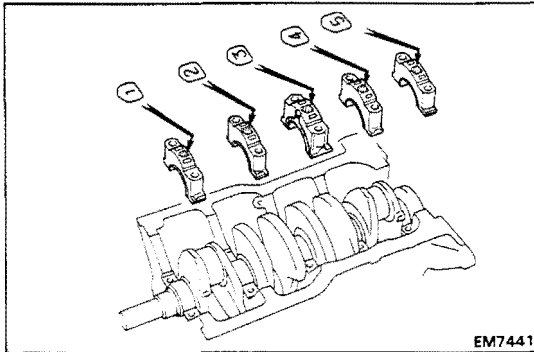

EM7441

- (b) Install the five main bearing caps in their proper locations.

**HINT:** Each bearing cap has a number and front mark.

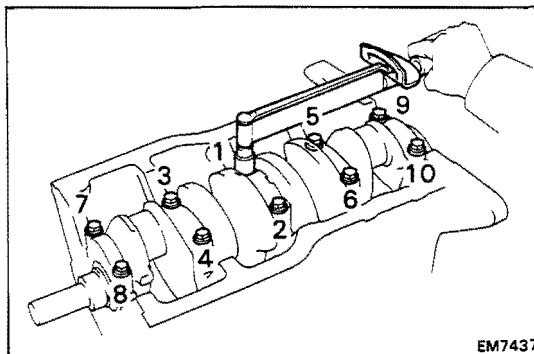

EM7437

- (c) Apply a light coat of engine oil on the threads and under the heads of the main bearing caps.

- (d) Install and uniformly tighten the ten bolts of the main bearing caps in several passes in the sequence shown.

**Torque:** 600 kg-cm (43 ft-lb, 59 N·m)

- (e) Check that the crankshaft turns smoothly.

- (f) Check the crankshaft thrust clearance.  
(See step 5 on page EM-152)

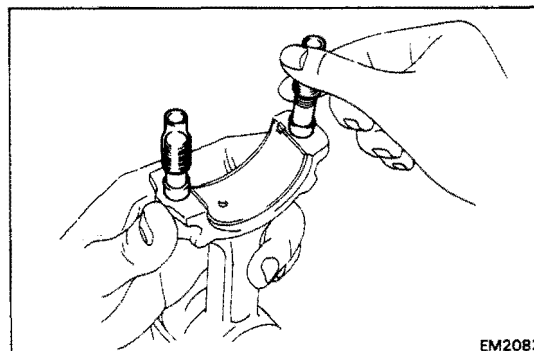

EM2082

### 5. INSTALL PISTON AND CONNECTING ROD ASSEMBLIES

- (a) Cover the connecting rod bolts with a short piece of hose to protect the crankshaft from damage.

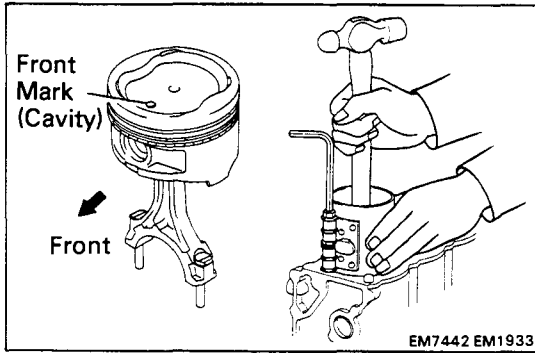

- (b) Using a piston ring compressor, push the correctly numbered piston and connecting rod assemblies into each cylinder with the front mark of the piston facing forward.

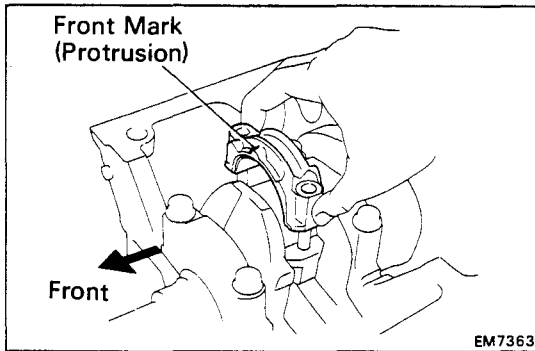

## 6. INSTALL CONNECTING ROD CAPS

### A. Place connecting rod cap on connecting rod

- (a) Match the numbered connecting rod cap with the connecting rod.
- (b) Install the connecting rod cap with the front mark facing forward.

### B. Install connecting rod cap nuts

#### HINT:

- The cap nuts are tightened in two progressive steps (steps (b) and (d)).
- If any connecting rod bolt is broken or deformed, replace it.

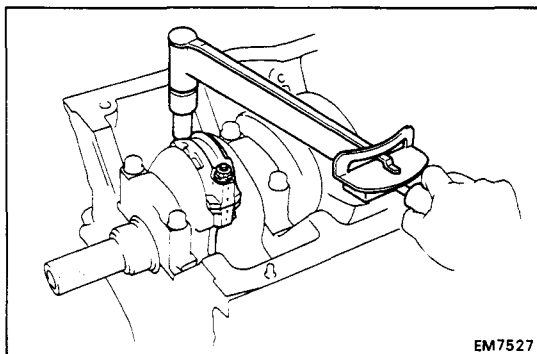

- (a) Apply a light coat of engine oil on the threads and under the cap nuts.
- (b) Using SST, install and alternately tighten the cap nuts in several passes.

SST 09011-38121

**Torque: 250 kg-cm (18 ft-lb, 25 N·m)**

If any one of the cap nuts does not meet the torque specification, replace the connecting rod bolt and cap nut as a set.

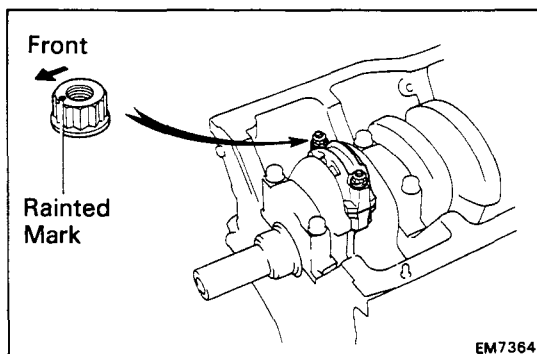

- (c) Mark the front of the cap nut with paint.

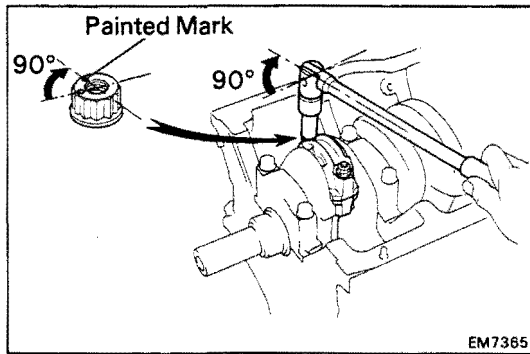

- (d) Retighten the cap nuts 90° in the numerical order as shown.
- (e) Check that the painted mark is now at a 90° angle to the front.
- (f) Check that the crankshaft turns smoothly.
- (g) Check the connecting rod thrust clearance. (See step 2 on page EM-150)

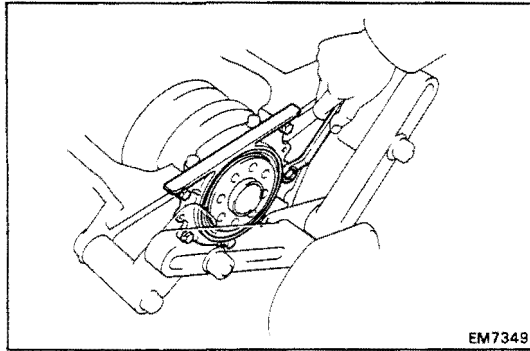

#### 7. INSTALL REAR OIL SEAL RETAINER

Install a new gasket and the retainer with the six bolts.

**Torque: 95 kg-cm (82 in.-lb, 9.3 N·m)**

### POST ASSEMBLY

1. (w/ OIL COOLER)  
INSTALL OIL COOLER (See page LU-18)
2. INSTALL OIL FILTER (See page LU-7)
3. INSTALL OIL PUMP AND OIL PAN  
(See pages LU-14 and 15)
4. INSTALL WATER PUMP AND ALTERNATOR  
ADJUSTING BAR (See pages CO-10 and 11)
5. INSTALL CYLINDER HEAD (See pages EM-87 to 96)
6. INSTALL PULLEYS AND TIMING BELT  
(See pages EM-40 to 44)

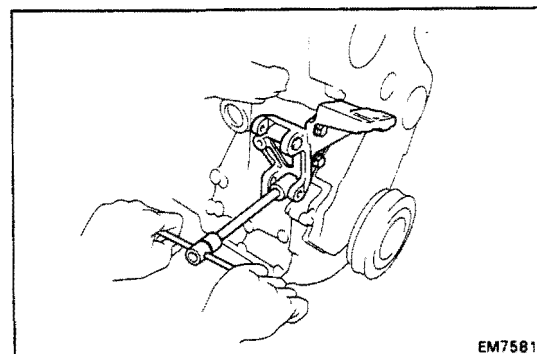

7. INSTALL RH ENGINE MOUNTING BRACKET  
Install the mounting bracket with the three bolts.  
**Torque: 530 kg-cm (38 ft.-lb, 52 N·m)**
8. INSTALL PS PUMP BRACKET  
Install the PS pump bracket with the three bolts.  
**Torque: 440 kg-cm (32 ft.-lb, 43 N·m)**
9. REMOVE ENGINE STAND

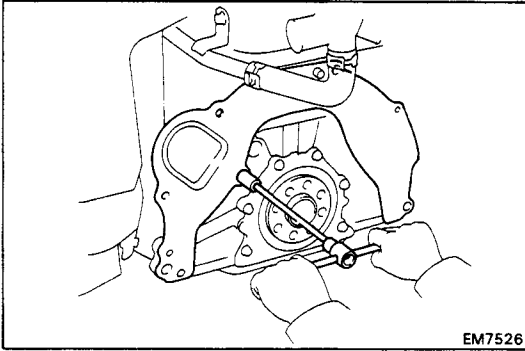
**10. INSTALL REAR END PLATE**

**Torque: 95 kg-cm (82 ft-lb, 9.3 N·m)**

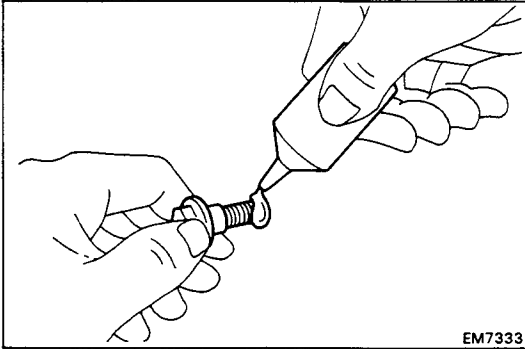
**13. (M/T)  
INSTALL FLYWHEEL**

- (a) Apply adhesive to two or three threads of the mount bolt end.

**Adhesive: Part No. 08833-00070, THREE BOND 1324 or equivalent**

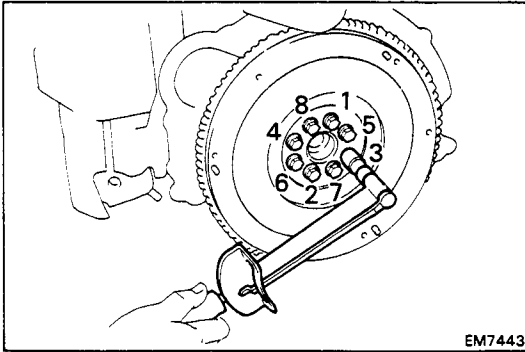

- (b) Install the flywheel on the crankshaft.  
(c) Install and uniformly tighten the mount bolts in several passes in the sequence shown.

**Torque: 900 kg-cm (65 ft-lb, 88 N·m)**

**14. (A/T)  
INSTALL DRIVE PLATE (See procedure of step 13)**

**Torque: 850 kg-cm (61 ft-lb, 83 N·m)**

**15. (M/T)  
INSTALL CLUTCH DISC AND COVER**



# CYLINDER BLOCK (3S-GE and 3S-GTE)

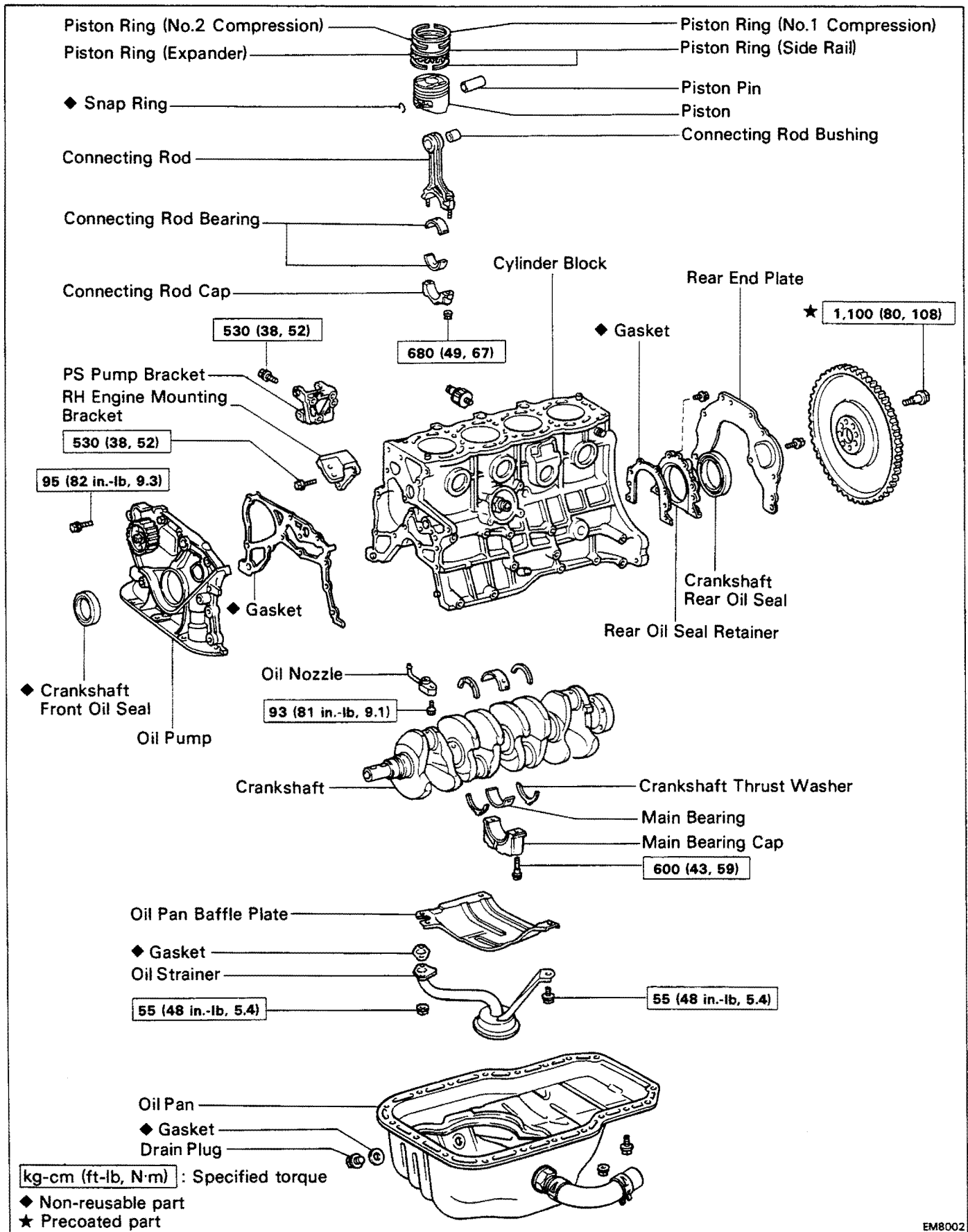

**PREPARATION FOR DISASSEMBLY**

1. (M/T)  
REMOVE CLUTCH COVER AND DISC
2. (M/T)  
REMOVE FLYWHEEL
3. (A/T)  
REMOVE DRIVE PLATE

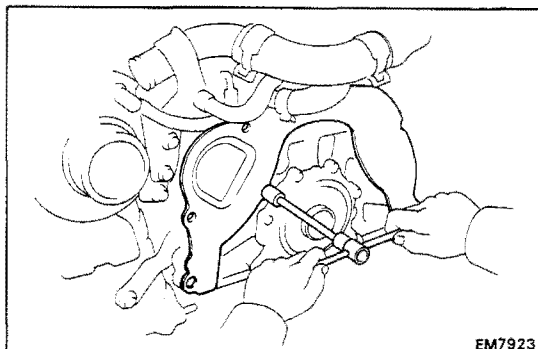

4. REMOVE REAR END PLATE  
Remove the bolt and end plate.

5. INSTALL ENGINE TO ENGINE STAND FOR DISASSEMBLY

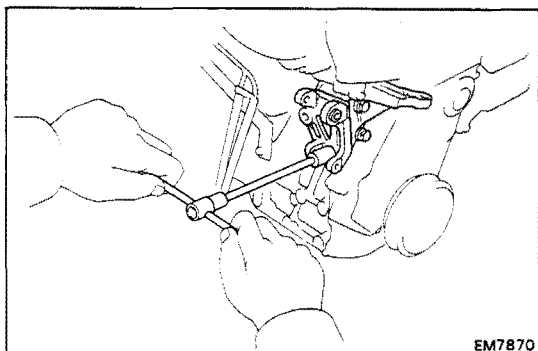

6. REMOVE RH ENGINE MOUNTING BRACKET  
Remove the three bolts and mounting bracket.

7. REMOVE PS PUMP BRACKET  
Remove the three bolts and PS pump bracket.

8. REMOVE TIMING BELT AND PULLEYS  
(See pages EM-45 to 50)

9. REMOVE CYLINDER HEAD  
3S-GE (See pages EM-101 to 107)  
3S-GTE (See pages EM-108 to 115)

10. REMOVE WATER PUMP AND IDLER PULLEY BRACKET (See pages CO-7 and 8)

11. REMOVE OIL PAN AND OIL PUMP  
(See pages LU-9 and 10)

12. REMOVE OIL FILTER (See page LU-7)

13. (w/ OIL COOLER)  
REMOVE OIL COOLER  
3S-GE (See pages LU-16 and 17)  
3S-GTE (See pages LU-19 and 20)

14. REMOVE KNOCK SENSOR  
Using SST, remove the knock sensor.  
SST 09816-30010

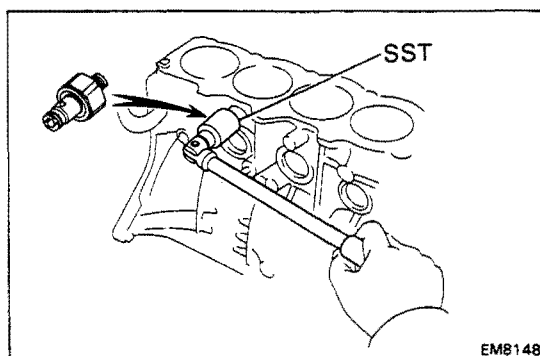

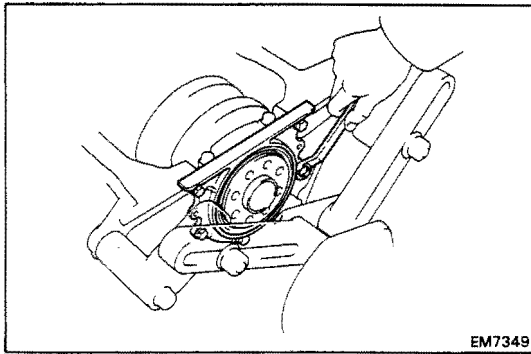

EM7349

## DISASSEMBLY OF CYLINDER BLOCK

(See page EM-174)

### 1. REMOVE REAR OIL SEAL RETAINER

Remove the six bolts, retainer and gasket.

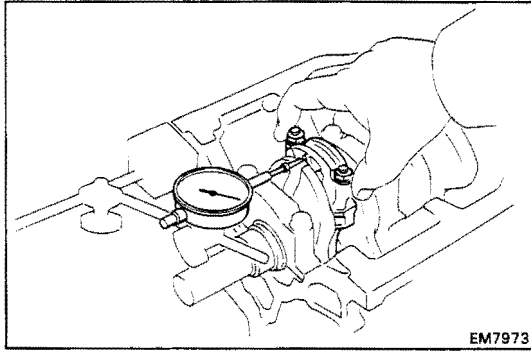

EM7973

### 2. CHECK CONNECTING ROD THRUST CLEARANCE

Using a dial indicator, measure the thrust clearance while moving the connecting rod back and forth.

**Standard thrust clearance:** 0.160 – 0.312 mm  
(0.0063 – 0.0123 in.)

**Maximum thrust clearance:** 0.35 mm (0.0138 in.)

If the thrust clearance is greater than maximum, replace the connecting rod assembly. If necessary, replace the crankshaft.

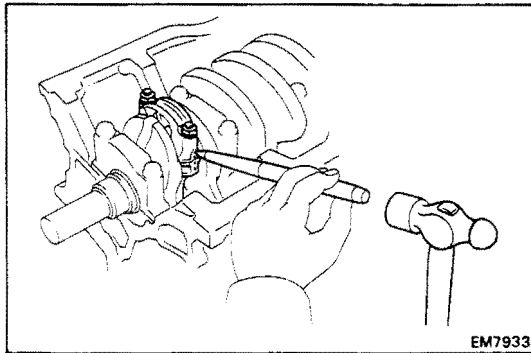

EM7933

### 3. REMOVE CONNECTING ROD CAPS AND CHECK OIL CLEARANCE

(a) Using a punch or numbering stamp, place the matchmarks on the connecting rod and cap to ensure correct reassembly.

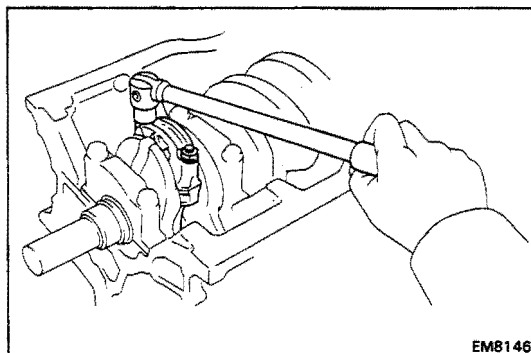

EM8146

(b) Remove the connecting rod cap nuts.

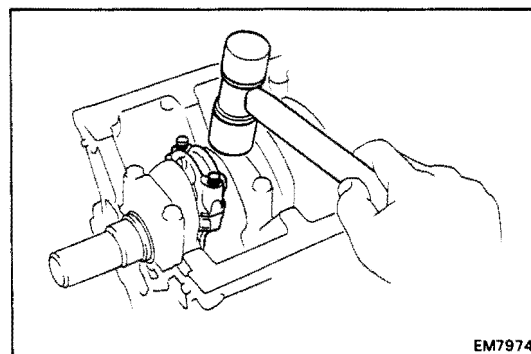

EM7974

(c) Using a plastic-faced hammer, lightly tap the connecting rod bolts and lift off the connecting rod cap.

**HINT:** Keep the lower bearing inserted with the connecting cap.

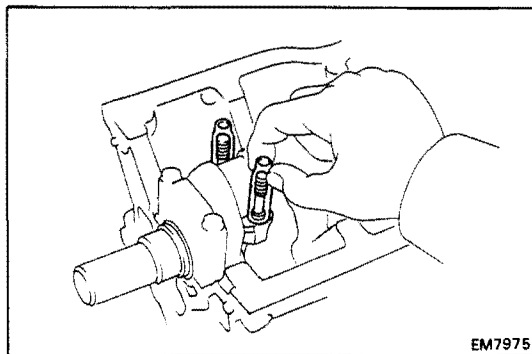

- (d) Cover the connecting rod bolts with a short piece of hose to protect the crankshaft from damage.

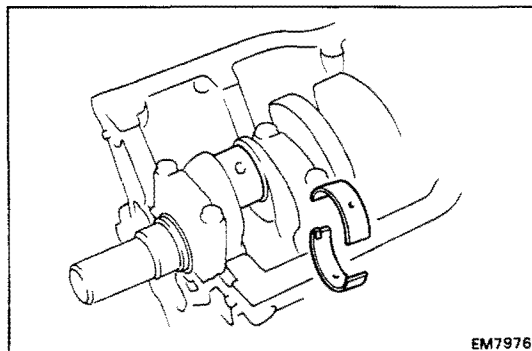

- (e) Clean crank pin and bearing.  
 (f) Check the crank pin and bearing for pitting and scratches.

If the crank pin or bearing is damaged, replace the bearings. If necessary, grind or replace the crankshaft.

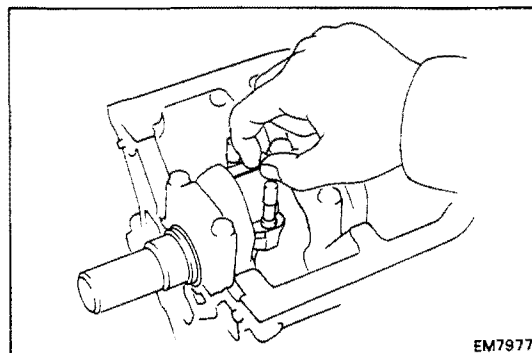

- (g) Lay a strip of Plastigage across the crank pin.

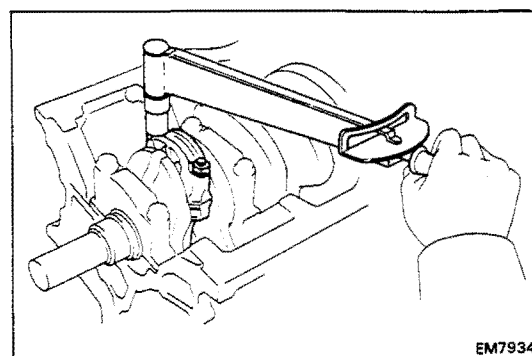

- (h) Install the connecting rod cap.  
 (See step 6 on page EM-195)

**Torque: 680 kg-cm (49 ft-lb, 67 N·m)**

**NOTICE: Do not turn the crankshaft.**

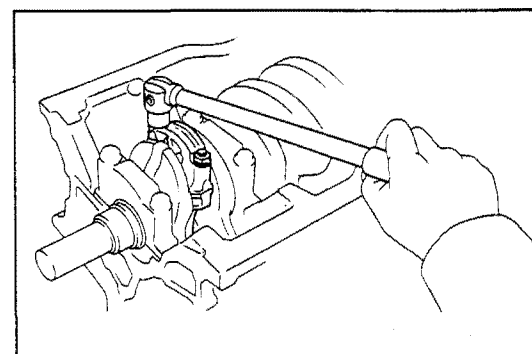

- (i) Remove the connecting rod cap.  
 (See procedures (b) and (c) above)

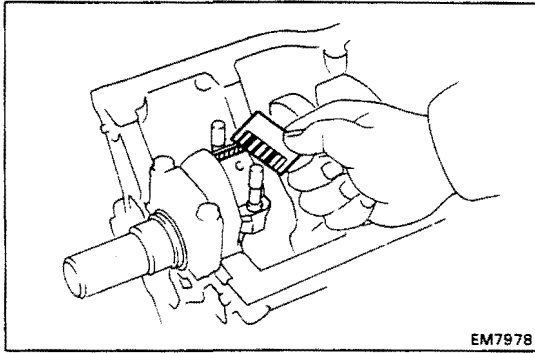

EM7978

(j) Measure the Plastigage at its widest point.

**Standard oil clearance:**

<b>STD</b>	<b>0.024 – 0.055 mm</b> <b>(0.0009 – 0.0022 in.)</b>
<b>U/S 0.25</b>	<b>0.023 – 0.069 mm</b> <b>(0.0009 – 0.0027 in.)</b>

**Maximum oil clearance: 0.08 mm (0.0031 in.)**

If the oil clearance is greater than maximum, replace the bearings. If necessary, grind or replace the crankshaft.

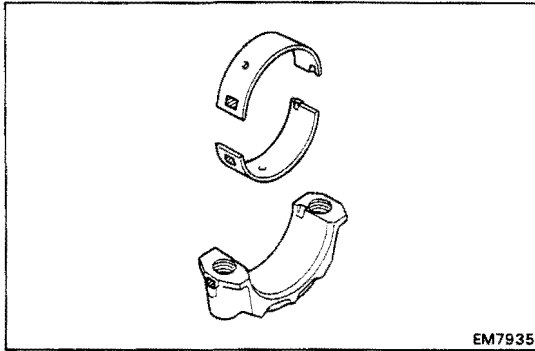

EM7935

**HINT:** If using a standard bearing, replace it with one having the same number marked on the connecting rod cap. There are three sizes of standard bearings, marked "1", "2" and "3" accordingly.

**Standard sized bearing center wall thickness:**

<b>Mark "1"</b>	<b>1.484 – 1.488 mm</b> <b>(0.0584 – 0.0586 in.)</b>
<b>Mark "2"</b>	<b>1.488 – 1.492 mm</b> <b>(0.0586 – 0.0587 in.)</b>
<b>Mark "3"</b>	<b>1.492 – 1.496 mm</b> <b>(0.0587 – 0.0589 in.)</b>

(k) Completely remove the Plastigage.

#### 4. REMOVE PISTON AND CONNECTING ROD ASSEMBLIES

- Using a ridge reamer, remove all the carbon from the top of the cylinder.
- Cover the connecting rod bolts.  
(See page EM-177)
- Push the piston, connecting rod assembly and upper bearing through the top of the cylinder block.

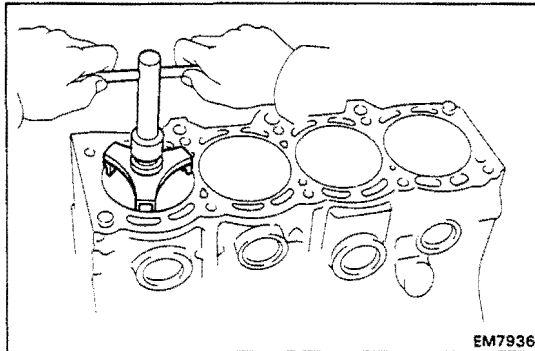

EM7936

**HINT:**

- Keep the bearings, connecting rod and cap together.
- Arrange the piston and connecting rod assemblies in correct order.

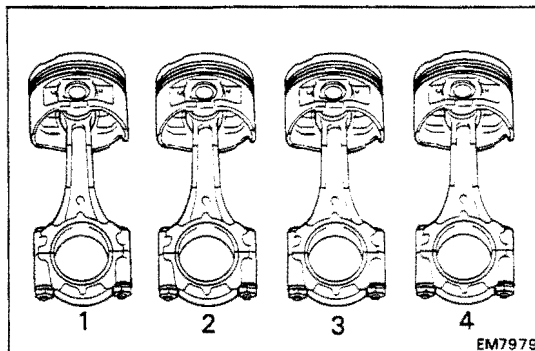

EM7979

#### 5. CHECK CRANKSHAFT THRUST CLEARANCE

Using a dial indicator, measure the thrust clearance while prying the crankshaft back and forth with a screwdriver.

**Standard thrust clearance: 0.020 – 0.220 mm**  
**(0.0008 – 0.0087 in.)**

**Maximum thrust clearance: 0.30 mm (0.0118 in.)**

If the thrust clearance is greater than maximum, replace the thrust washers as a set.

**Thrust washer thickness: 2.440 – 2.490 mm**  
**(0.0961 – 0.0980 in.)**

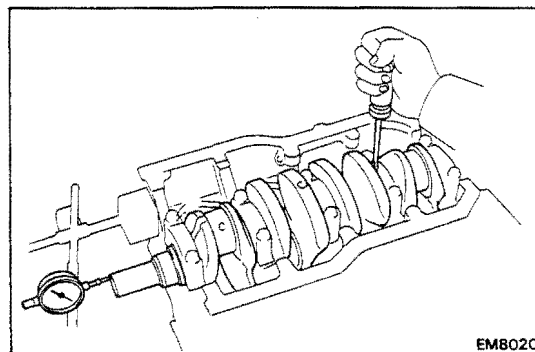

EM8020

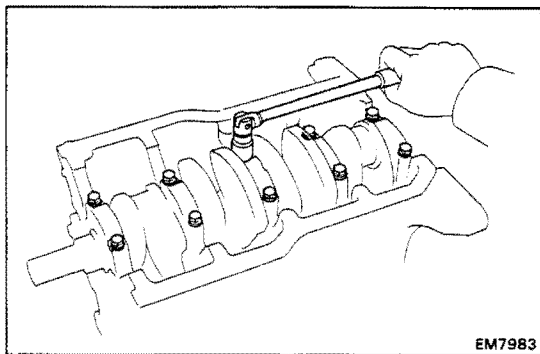

EM7983

## 6. REMOVE MAIN BEARING CAPS AND CHECK OIL CLEARANCE

(a) Remove the main bearing cap bolts.

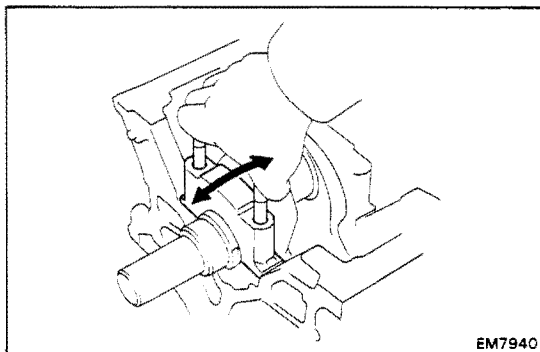

EM7940

(b) Using the removed main bearing cap bolts, pry the main bearing cap back and forth, and remove the main bearing caps, lower bearings and lower thrust washers (No.3 main bearing cap only).

### HINT:

- Keep the lower bearing and main bearing cap together.
- Arrange the main bearing caps and lower thrust washers in correct order.

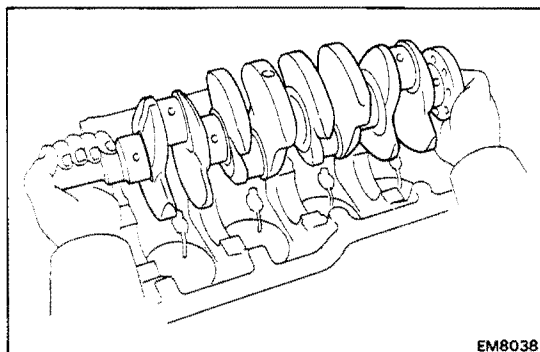

EM8038

(c) Lift out the crankshaft.

HINT: Keep the upper bearing and upper thrust washers together with the cylinder block.

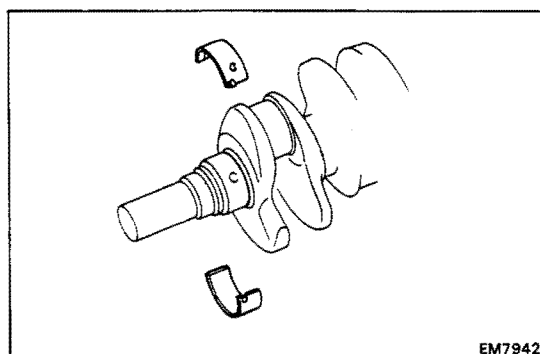

EM7942

(d) Clean each main journal and bearing.

(e) Check each main journal and bearing for pitting and scratches.

If the journal or bearing is damaged, replace the bearings. If necessary, grind or replace the crankshaft.

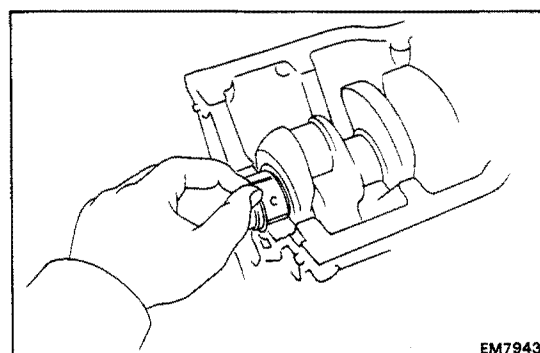

EM7943

(f) Place the crankshaft on the cylinder block.

(g) Lay a strip of Plastigage across each journal.

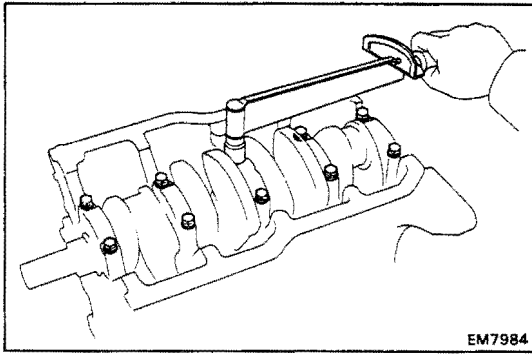

(h) Install the main bearing caps.  
(See step 4 on page EM-194)

**Torque: 600 kg-cm (43 ft-lb, 59 N·m)**

**NOTICE: Do not turn the crankshaft.**

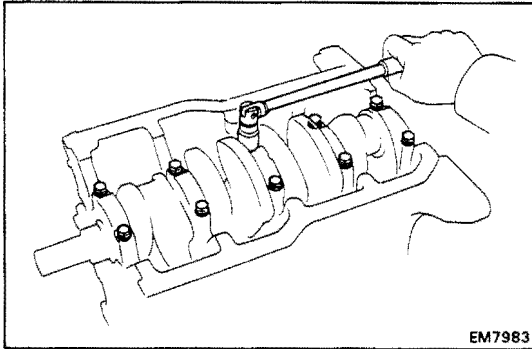

(i) Remove the main bearing caps.  
(See procedures (a) and (b) above)

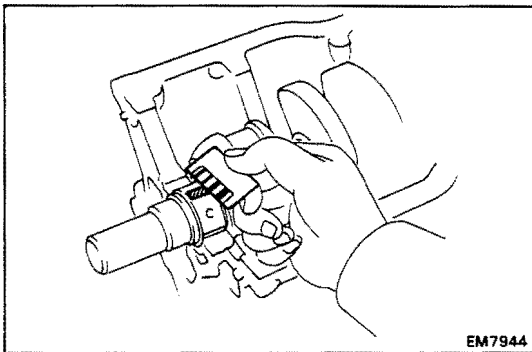

(j) Measure the Plastigage at its widest point.

**Standard clearance:**

<b>No.3</b>	<b>STD</b>	<b>0.025 – 0.044 mm</b> (0.0010 – 0.0017 in.)
	<b>U/S 0.25</b>	<b>0.021 – 0.061 mm</b> (0.0008 – 0.0024 in.)
<b>Others</b>	<b>STD</b>	<b>0.015 – 0.034 mm</b> (0.0006 – 0.0013 in.)
	<b>U/S 0.25</b>	<b>0.029 – 0.069 mm</b> (0.0011 – 0.0027 in.)

**Maximum clearance: 0.08 mm (0.0031 in.)**

**HINT:** If replacing the cylinder block subassembly, the bearing standard clearance will be:

<b>No.3</b>	<b>0.027 – 0.054 mm</b> (0.0011 – 0.0021 in.)
<b>Others</b>	<b>0.017 – 0.044 mm</b> (0.0007 – 0.0017 in.)

If the oil clearance is greater than maximum, replace the bearings. If necessary, grind or replace the crankshaft.

**HINT:** If using a standard bearing, replace it with one having the same number. If the number of the bearing cannot be determined, select the correct bearing by adding together the numbers imprinted on the cylinder block and crankshaft, then select the bearing with the same number as the total. There are five sizes of standard bearings, marked "1," "2," "3," "4" and "5" accordingly.

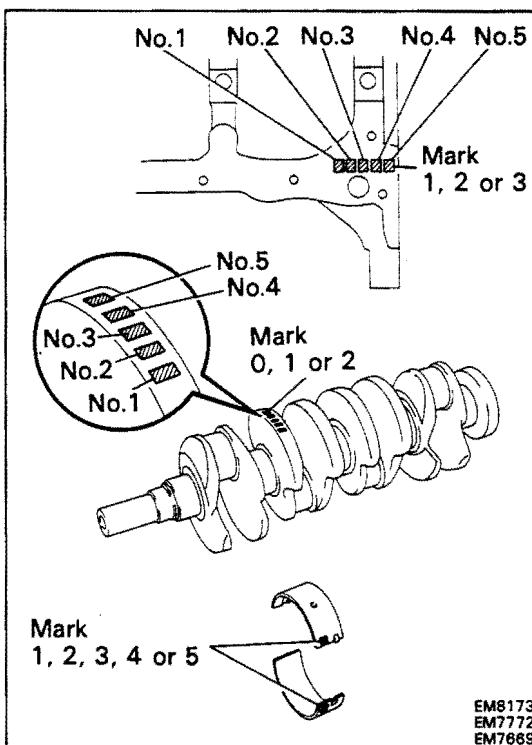

Cylinder block / Crankshaft / Bearing	Number marked								
	1			2			3		
Cylinder block									
Crankshaft	0	1	2	0	1	2	0	1	2
Bearing	1	2	3	2	3	4	3	4	5

**EXAMPLE:** Cylinder block "2" + Crankshaft "1"  
= Bearing "3"

**(Reference)****Cylinder block main journal bore diameter:**

Mark "1" 59.020 – 59.026 mm  
(2.3236 – 2.3239 in.)

Mark "2" 59.026 – 59.032 mm  
(2.3239 – 2.3241 in.)

Mark "3" 59.032 – 59.038 mm  
(2.3241 – 2.3243 in.)

**Crankshaft journal diameter:**

Mark "0" 54.998 – 55.003 mm  
(2.1653 – 2.1655 in.)

Mark "1" 54.993 – 54.998 mm  
(2.1651 – 2.1653 in.)

Mark "2" 54.988 – 54.993 mm  
(2.1649 – 2.1651 in.)

**Standard sized bearing center wall thickness:**

No.3 Mark "1" 1.992 – 1.995 mm  
(0.0784 – 0.0785 in.)

Mark "2" 1.995 – 1.998 mm  
(0.0785 – 0.0787 in.)

Mark "3" 1.998 – 2.001 mm  
(0.0787 – 0.0788 in.)

Mark "4" 2.001 – 2.004 mm  
(0.0788 – 0.0789 in.)

Mark "5" 2.004 – 2.007 mm  
(0.0789 – 0.0790 in.)

Others Mark "1" 1.997 – 2.000 mm  
(0.0786 – 0.0787 in.)

Mark "2" 2.000 – 2.003 mm  
(0.0787 – 0.0789 in.)

Mark "3" 2.003 – 2.006 mm  
(0.0789 – 0.0790 in.)

Mark "4" 2.006 – 2.009 mm  
(0.0790 – 0.0791 in.)

Mark "5" 2.009 – 2.012 mm  
(0.0791 – 0.0792 in.)

(k) Completely remove the Plastigage.

**7. REMOVE CRANKSHAFT**

(a) Lift out the crankshaft.

(b) Remove the upper bearings and upper thrust washers from cylinder block.

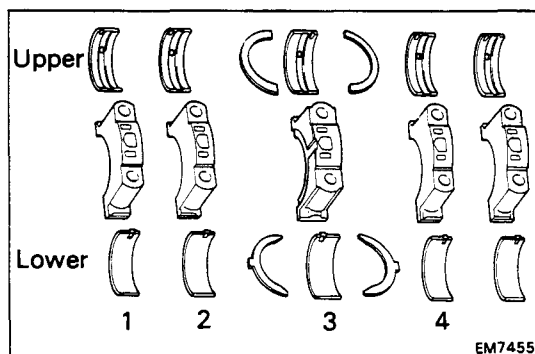
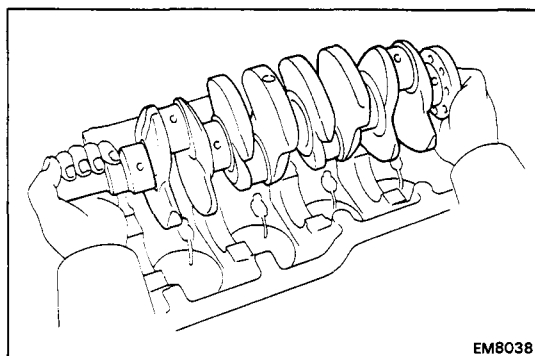

**HINT:** Arrange the main bearing caps, bearings and thrust washers in correct order.

**8. REMOVE OIL NOZZLES (See page LU-23)**



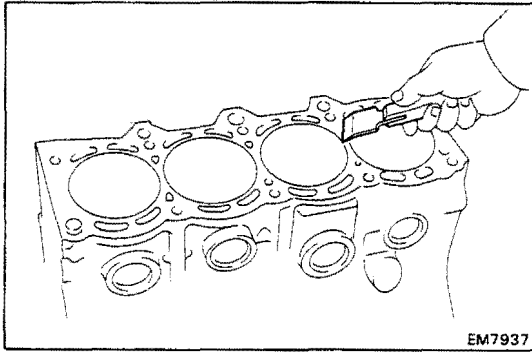

## INSPECTION OF CYLINDER BLOCK

### 1. CLEAN CYLINDER BLOCK

#### A. Remove gasket material

Using a gasket scraper, remove all the gasket material from the top surface of the cylinder block.

#### B. Clean cylinder block

Using a soft brush and solvent, thoroughly clean the cylinder block.

### 2. INSPECT TOP SURFACE OF CYLINDER BLOCK FOR FLATNESS

Using a precision straight edge and feeler gauge, measure the surfaces contacting the cylinder head gasket for warpage.

**Maximum warpage: 0.05 mm (0.0020 in.)**

If warpage is greater than maximum, replace the cylinder block.

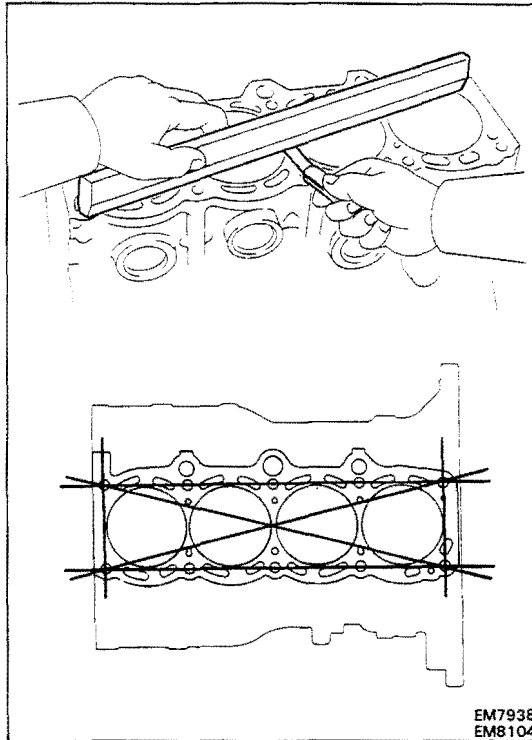

### 3. INSPECT CYLINDER FOR VERTICAL SCRATCHES

Visually check the cylinder for vertical scratches.

If deep scratches are present, replace the cylinder block.

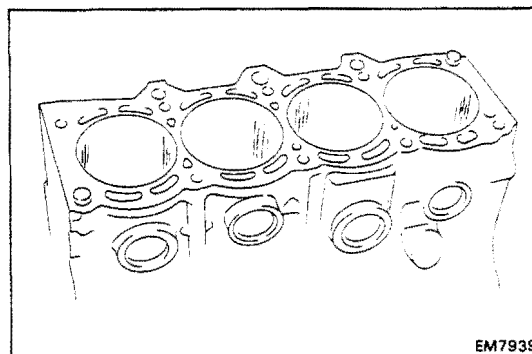

### 4. INSPECT CYLINDER BORE DIAMETER

**HINT:** There are three sizes of the standard cylinder bore diameter, marked "1", "2" and "3" accordingly. The mark is stamped on the top of the cylinder block.

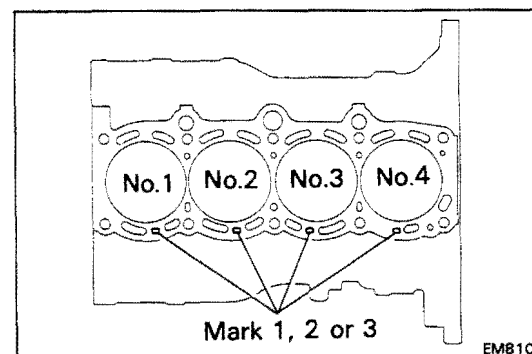

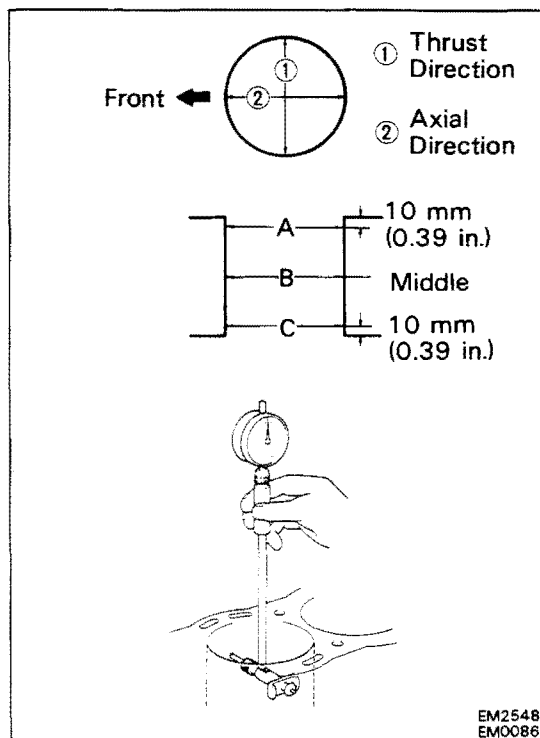

Using a cylinder gauge, measure the cylinder bore diameter at positions A, B and C in the thrust axial directions.

**Standard diameter:**

Mark "1"	86.000 – 86.010 mm (3.3858 – 3.3862 in.)
Mark "2"	86.010 – 86.020 mm (3.3862 – 3.3866 in.)
Mark "3"	86.020 – 86.030 mm (3.3866 – 3.3870 in.)

**Maximum diameter:** 86.23 mm (3.3949 in.)

If the diameter is greater than maximum, replace the cylinder block.

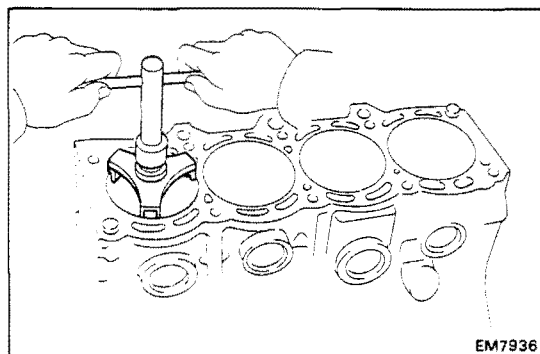

**5. REMOVE CYLINDER RIDGE**

If the wear is less than 0.2 mm (0.008 in.), using a ridge reamer, grind the top of the cylinder.

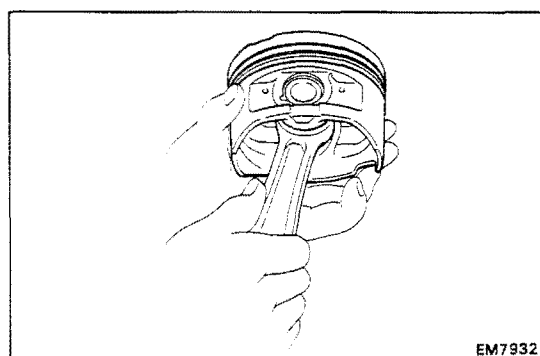

**DISASSEMBLY OF PISTON AND CONNECTING ROD ASSEMBLIES**

**1. CHECK FIT BETWEEN PISTON AND PISTON PIN**

Try to move the piston back and forth on the piston pin. If any movement is felt, replace the piston and pin as a set.

**2. REMOVE PISTON RINGS**

(a) Using a piston ring expander, remove the two compression rings.

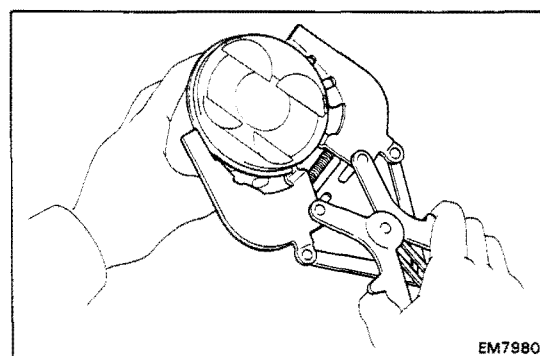

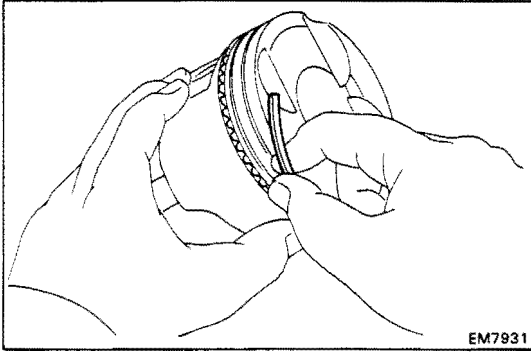

- (b) Remove the two side rails and oil ring expander by hand.

HINT: Arrange the rings in correct order only.

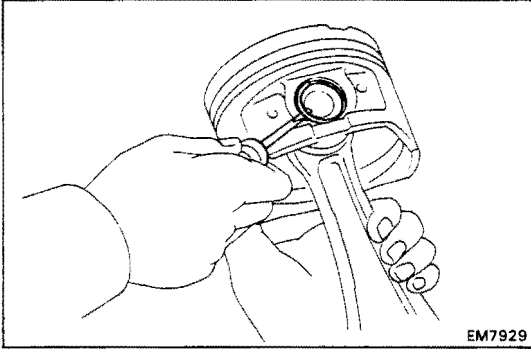

### 3. DISCONNECT CONNECTING ROD FROM PISTON

- (a) Using a small screwdriver, pry out the two snap rings.

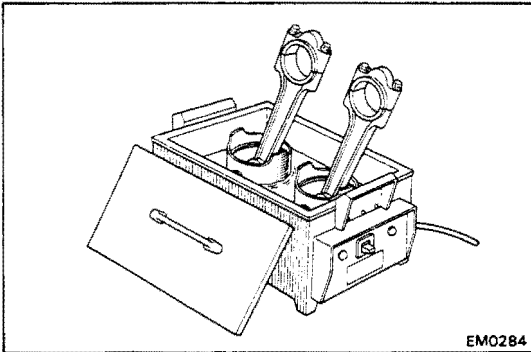

- (b) Gradually heat the piston to 80 – 90°C (176 – 194°F).

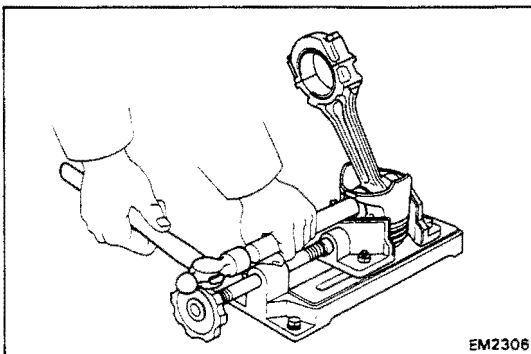

- (c) Using plastic-faced hammer and brass bar, lightly tap out the piston pin and remove the connecting rod.

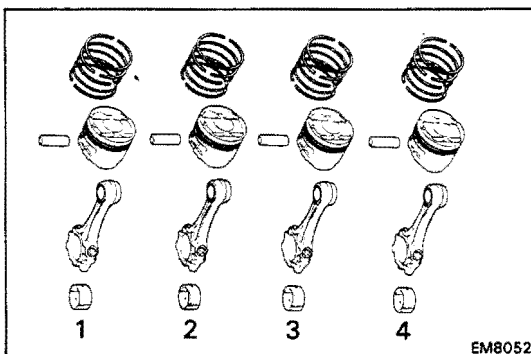

HINT:

- The piston and pin are a matched set.
- Arrange the pistons, pins, rings, connecting rods and bearings in correct order.

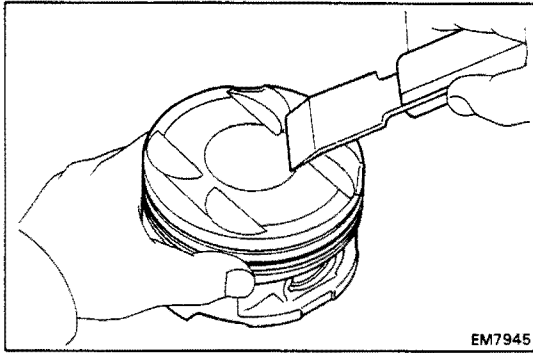

EM7945

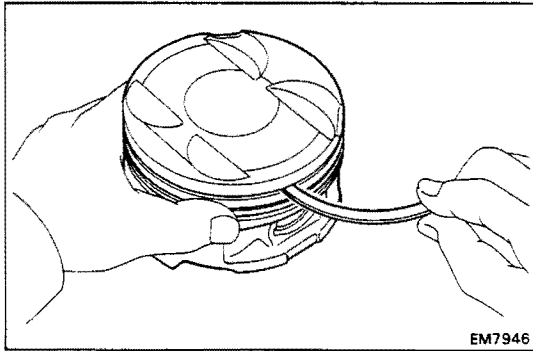

EM7946

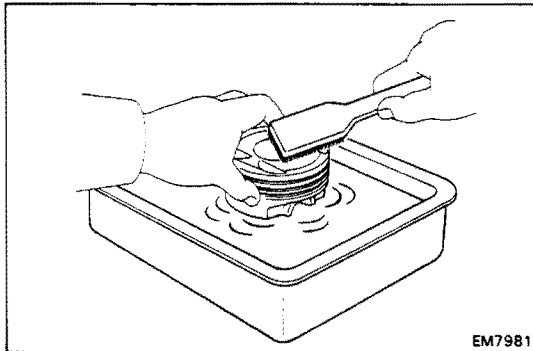

EM7981

## INSPECTION OF PISTON AND CONNECTING ROD ASSEMBLIES

### 1. CLEAN PISTON

- (a) Using a gasket scraper, remove the carbon from the piston top.

- (b) Using a groove cleaning or broken ring, clean the piston ring grooves.

- (c) Using solvent and a brush, thoroughly clean the piston.

**NOTICE:** Do not use a wire brush.

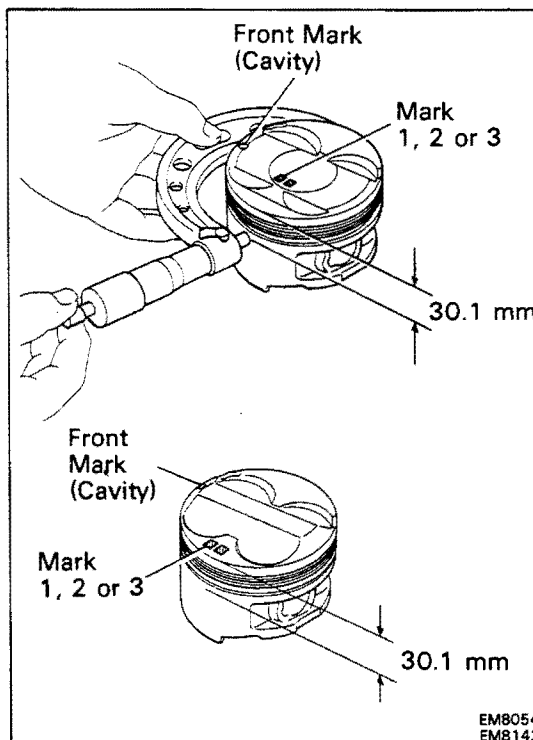
EM8054  
EM8142

### 2. INSPECT PISTON

#### A. Inspect piston oil clearance

**HINT:** There are three sizes of the standard piston diameter, marked "1", "2" and "3" accordingly. The mark is stamped on the piston top.

- (a) Using a micrometer, measure the piston diameter at right angles to the piston pin center line, 30.1 mm (1.185 in.) from the piston head.

**Piston diameter:**

3S-GE	Mark "1"	85.960 – 85.970 mm (3.3842 – 3.3846 in.)
	Mark "2"	85.970 – 85.980 mm (3.3846 – 3.3850 in.)
	Mark "3"	85.980 – 85.990 mm (3.3850 – 3.3854 in.)
3S-GTE	Mark "1"	85.920 – 85.930 mm (3.3827 – 3.3831 in.)
	Mark "2"	85.930 – 85.940 mm (3.3831 – 3.3835 in.)
	Mark "3"	85.940 – 85.950 mm (3.3835 – 3.3839 in.)

(b) Measure the cylinder bore diameter in the thrust directions.

(See step 4 on page EM-183)

(c) Subtract the piston diameter measurement from the minimum cylinder bore diameter measurement.

**Standard oil clearance:**

**3S-GE** 0.030 – 0.050 mm  
(0.0012 – 0.0020 in.)

**3S-GTE** 0.070 – 0.090 mm  
(0.0028 – 0.0035 in.)

**Maximum oil clearance:**

**3S-GE** 0.070 mm (0.0028 in.)

**3S-GTE** 0.110 mm (0.0043 in.)

If the oil clearance is greater than maximum, replace all the four pistons. If necessary, replace the cylinder block.

**HINT (Use new cylinder block):** Use a piston with the same number mark as the cylinder bore diameter marked on the cylinder block.

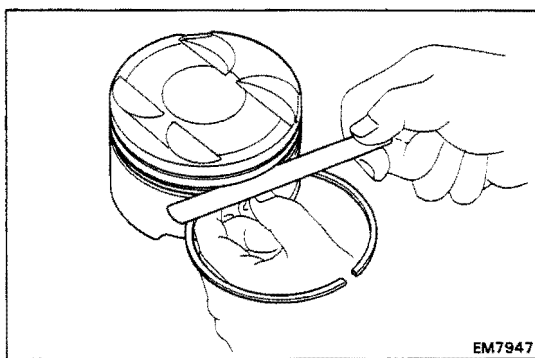
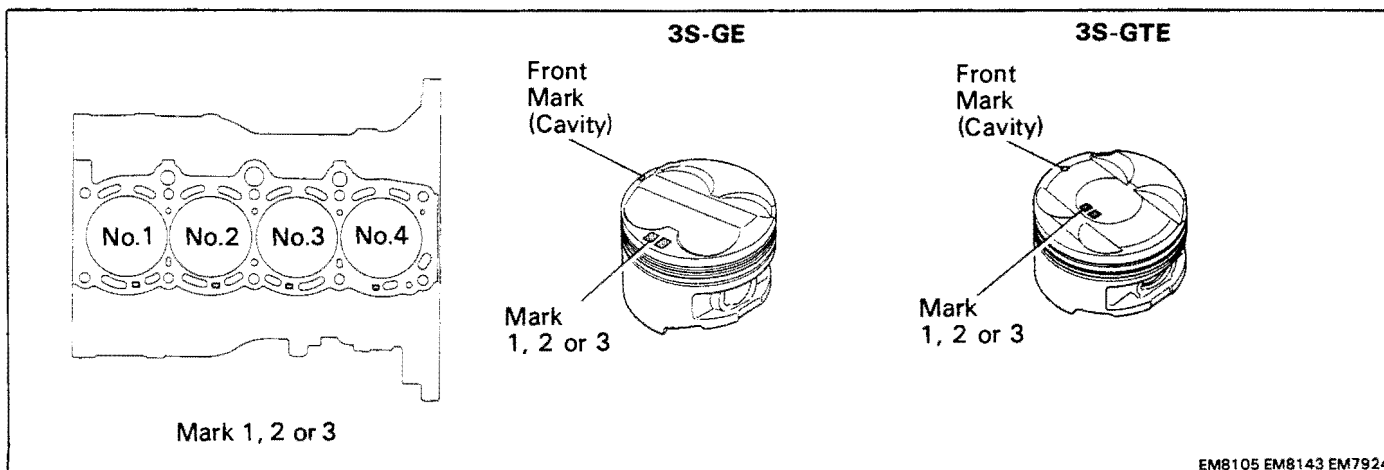

**B. Inspect piston ring groove clearance**

Using a feeler gauge, measure the clearance between new piston ring and the wall of the piston ring groove.

**Ring groove clearance:**

**No.1** 0.040 – 0.080 mm  
(0.0016 – 0.0031 in.)

**No.2** 0.030 – 0.070 mm  
(0.0012 – 0.0028 in.)

If the clearance is greater than maximum, replace the piston.

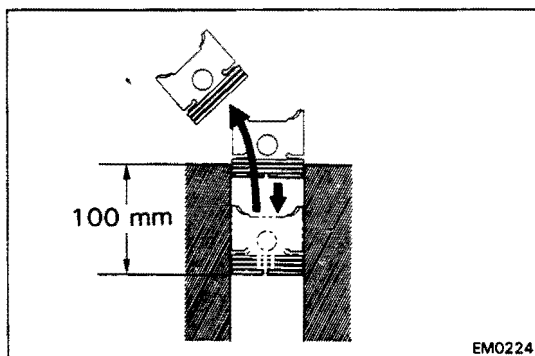

**C. Inspect piston ring end gap**

(a) Insert the piston ring into the cylinder bore.

(b) Using a piston, push the piston ring a little beyond the bottom of the ring travel, 100 mm (3.94 in.) from the top of the cylinder block.

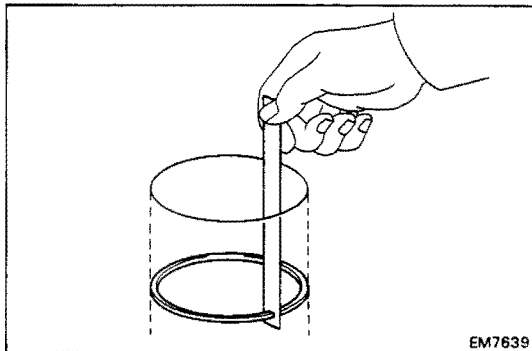

EM7639

(c) Using a feeler gauge, measure the end gap.

**Standard end gap:**

<b>w/ TWC</b>	<b>No.1</b>	<b>0.330 – 0.550 mm</b> <b>(0.0130 – 0.0217 in.)</b>
	<b>No.2</b>	<b>0.450 – 0.670 mm</b> <b>(0.0177 – 0.0264 in.)</b>
	<b>Oil (Side rail)</b>	<b>0.200 – 0.600 mm</b> <b>(0.0079 – 0.0217 in.)</b>
<b>w/o TWC</b>	<b>No.1</b>	<b>0.330 – 0.550 mm</b> <b>(0.0130 – 0.0217 in.)</b>
	<b>No.2</b>	<b>0.200 – 0.420 mm</b> <b>(0.0079 – 0.0165 in.)</b>
	<b>Oil (Side rail)</b>	<b>0.300 – 1.000 mm</b> <b>(0.0118 – 0.0394 in.)</b>

**Maximum end gap:**

<b>w/ TWC</b>	<b>No.1</b>	<b>0.85 mm (0.0335 in.)</b>
	<b>No.2</b>	<b>0.97 mm (0.0382 in.)</b>
	<b>Oil (Side rail)</b>	<b>0.90 mm (0.0354 in.)</b>
<b>w/o TWC</b>	<b>No.1</b>	<b>0.85 mm (0.0335 in.)</b>
	<b>No.2</b>	<b>0.72 mm (0.0283 in.)</b>
	<b>Oil (Side rail)</b>	<b>1.30 mm (0.0512 in.)</b>

If the end gap is greater than maximum, replace the piston ring. If the end gap is greater than maximum, even with a new piston ring, replace the cylinder block.

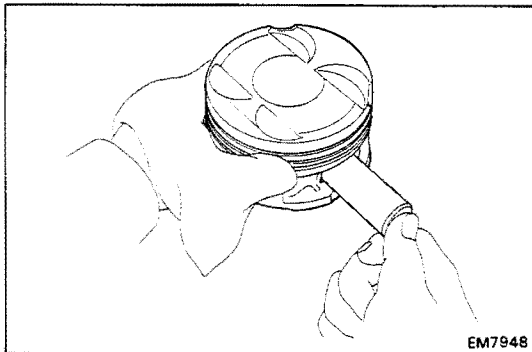

EM7948

**D. Inspect piston pin fit**

At 60°C (140°F), you should be able to push the piston pin into the piston pin hole with your thumb.

**3. INSPECT CONNECTING ROD**

**A. Inspect connecting rod alignment**

Using rod aligner and feeler gauge, check the connecting rod alignment.

- Check for bending.

**Maximum bending:**

**0.05 mm (0.0020 in.) per 100 mm (3.94 in.)**

If bend is greater than maximum, replace the connecting rod assembly.

- Check for twist.

**Maximum twist:**

**0.15 mm (0.0059 in.) per 100 mm (3.94 in.)**

If twist is greater than maximum, replace the connecting rod assembly.

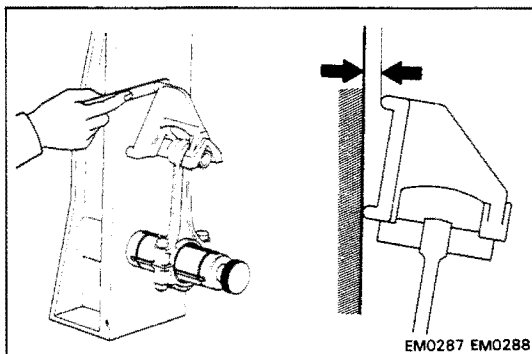

EM0287 EM0288

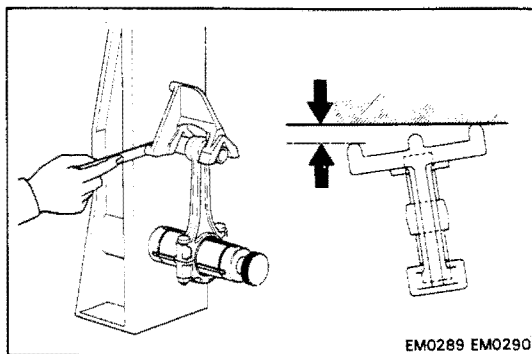

EM0289 EM0290

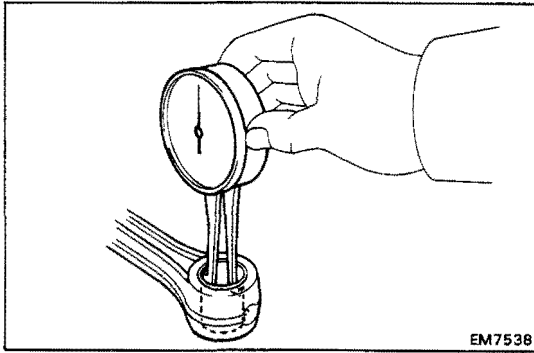
**B. Inspect piston pin oil clearance**

- (a) Using a caliper gauge, measure the inside diameter of the connecting rod bushing.

**Bushing inside diameter: 22.005 – 22.017 mm  
(0.8663 – 0.8668 in.)**

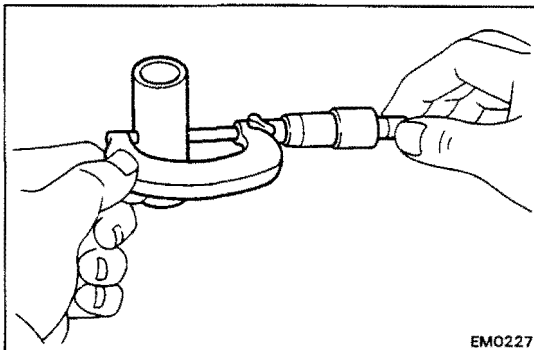

- (b) Using a micrometer, measure the piston pin diameter.

**Piston pin diameter: 21.997 – 22.009 mm  
(0.8660 – 0.8665 in.)**

- (c) Subtract the piston pin diameter measurement from the bushing inside diameter measurement.

**Standard oil clearance: 0.005 – 0.011 mm  
(0.0002 – 0.0004 in.)**

**Maximum oil clearance: 0.05 mm (0.0020 in.)**

If the oil clearance is greater than maximum, replace the bushing. If necessary, replace the piston and piston pin as a set.

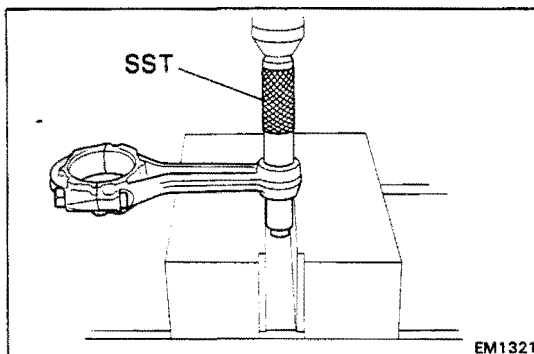
**C. If necessary, replace connecting rod bushing**

- (a) Using SST and a press, press out the bushing.

**SST 09222-30010**

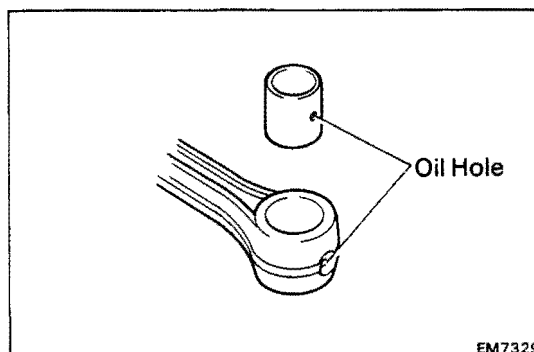

- (b) Align the oil holes of a new bushing and the connecting rod.

- (c) Using SST and a press, press in the bushing.

**SST 09222-30010**

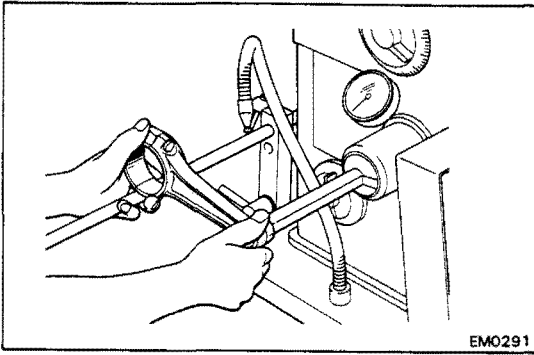

- (d) Using a pin hole grinder, hone the bushing to obtain the standard specified clearance (see step B above) between the bushing and piston pin.

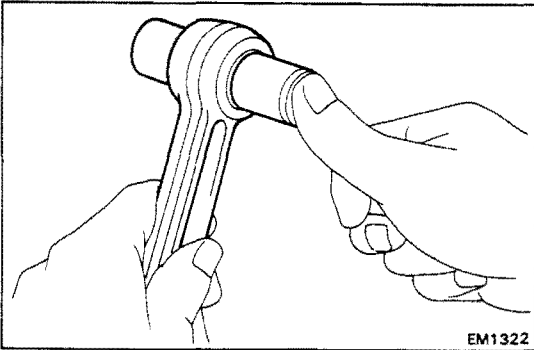

- (e) Check the piston pin fit at normal room temperature. Coat the piston pin with engine oil, and push it into the connecting rod with your thumb.



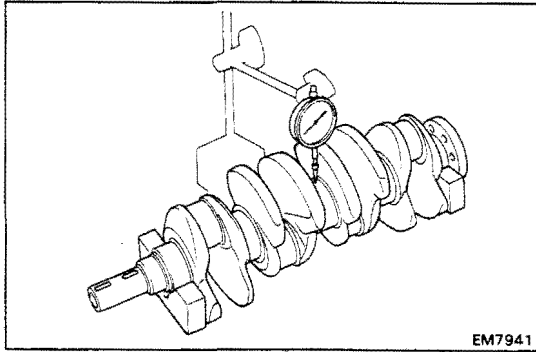

## INSPECTION AND REPAIR OF CRANKSHAFT

### 1. INSPECT CRANKSHAFT FOR RUNOUT

- (a) Place the crankshaft on V-blocks.
- (b) Using a dial indicator, measure the circle runout at the center journal.

**Maximum circle runout: 0.06 mm (0.0024 in.)**

If the circle runout is greater than maximum, replace the crankshaft.

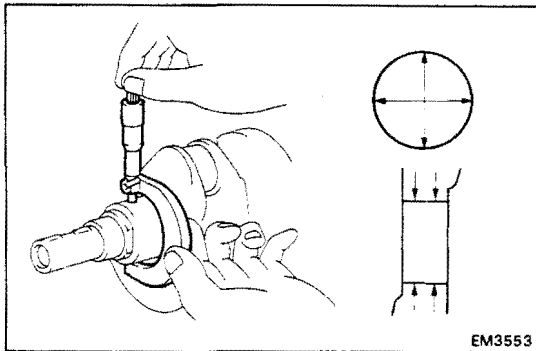

### 2. INSPECT MAIN JOURNALS AND CRANK PINS

- (a) Using a micrometer, measure the diameter of each main journal and crank pin.

**Main journal diameter:**

**STD size 54.988 – 55.003 mm**  
(2.1653 – 2.1655 in.)

**U/S 0.25 54.745 – 54.755 mm**  
(2.1553 – 2.1557 in.)

**Crank pin diameter:**

**STD size 47.985 – 48.000 mm**  
(1.8892 – 1.8898 in.)

**U/S 0.25 47.745 – 47.755 mm**  
(1.8797 – 1.8801 in.)

If the diameter is not as specified, check the oil clearance (See pages EM-170 to 174). If necessary, grind or replace the crankshaft.

- (b) Check each main journal and crank pin for taper and out-of-round as shown.

**Maximum taper and out-of-round: 0.02 mm**  
(0.0008 in.)

If the taper and out-of-round is greater than maximum, replace the crankshaft.

### 3. IF NECESSARY, GRIND AND HONE MAIN JOURNALS AND/OR CRANK PINS

Grind and hone the main journals and/or crank pins to the finished undersized diameter (See procedure step 2).

Install new main journal and/or crank pin undersized bearings.

## REPLACEMENT OF CRANKSHAFT OIL SEALS

(See pages EM-165 and 166)

## ASSEMBLY OF PISTON AND CONNECTING ROD ASSEMBLIES

### 1. ASSEMBLE PISTON AND CONNECTING ROD

- (a) Install a new snap ring on one side of the piston pin hole.

**HINT:** Be sure end gap of the snap ring is not aligned with the pin hole cutout portion of the piston.

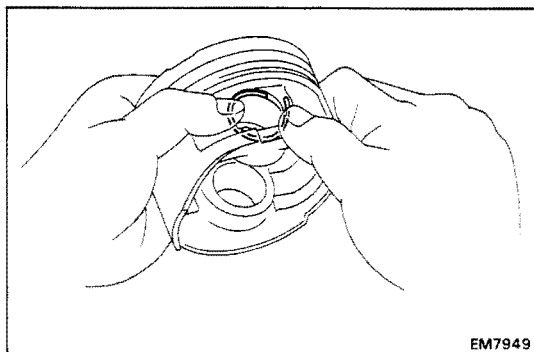

EM7949

- (b) Gradually heat the piston to 80 – 90°C (176 – 194°F).

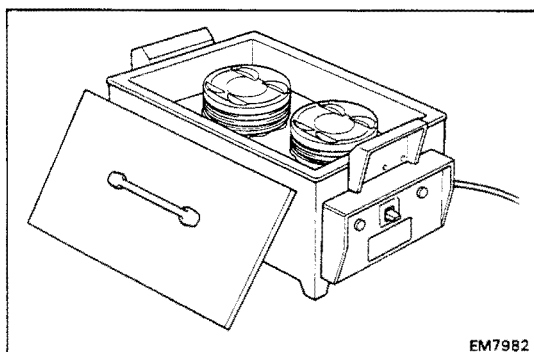

EM7982

- (c) Coat the piston pin with engine oil.  
 (d) Align the front marks of the piston and connecting rod, and push in the piston pin with your thumb.

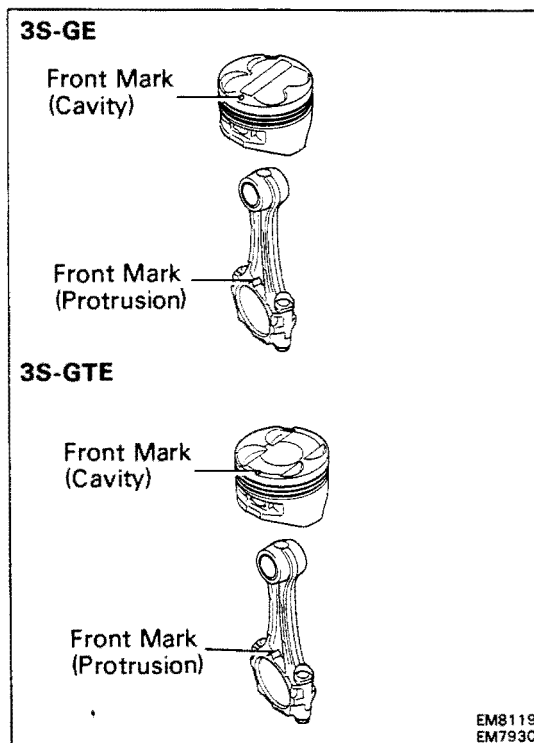
EM8119  
EM7930

- (e) Install a new snap ring on the other side of the piston pin hole.

**HINT:** Be sure end gap of the snap ring is not aligned with the pin hole cutout portion of the piston.

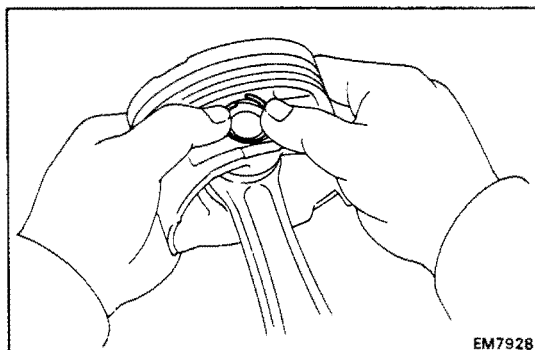

EM7928

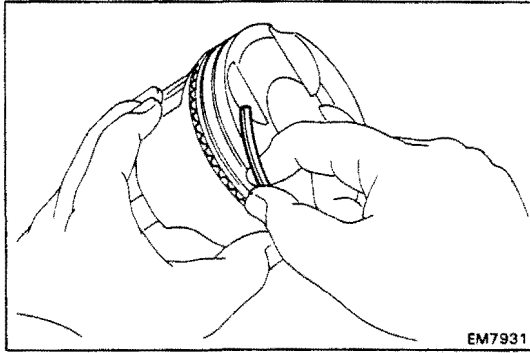

## 2. INSTALL PISTON RINGS

- (a) Install the oil ring expander and two side rails by hand.

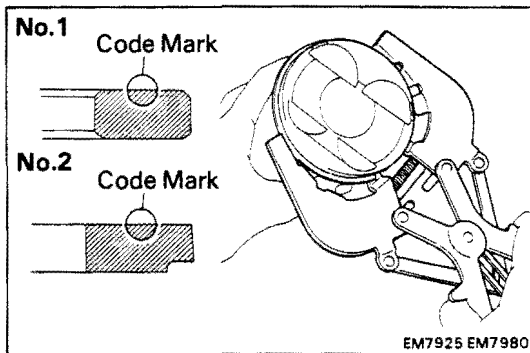

- (b) Using a piston ring expander, install the two compression rings with the code mark facing upward.

**Code mark: R**

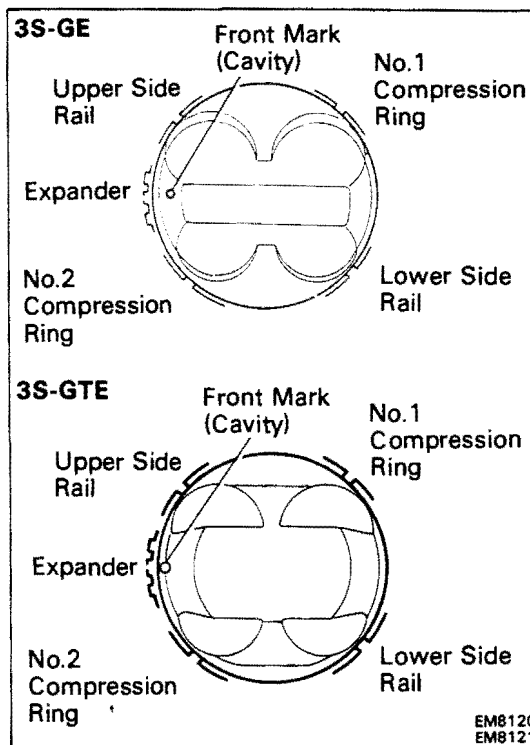

- (c) Position the piston rings so that the ring ends are as shown.

**NOTICE: Do not align the ring ends.**

## 3. INSTALL BEARINGS

- (a) Align the bearing claw with the groove of the connecting rod or connecting rod cap.
- (b) Install the bearings in the connecting rod and connecting rod cap.

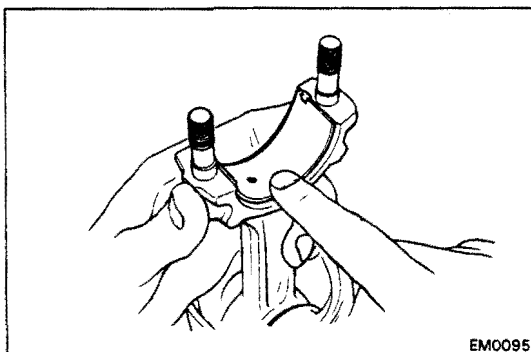

**ASSEMBLY OF CYLINDER BLOCK**

(See page EM-174)

**HINT:**

- Thoroughly clean all parts to be assembled.
- Before installing the parts, apply new engine oil to all sliding and rotating surfaces.
- Replace all gaskets, O-rings and oil seals with new parts.

**1. INSTALL OIL NOZZLES (See page LU-23)****2. INSTALL MAIN BEARINGS****HINT:**

- Main bearings come in widths of 19.2 mm (0.756 in.) and 23.0 mm (0.906 in.). Install the 23.0 mm (0.906 in.) bearings in the No.3 cylinder block journal position with the main bearing cap. Install the 19.2 mm (0.756 in.) bearings in the other positions.
- Upper bearings have an oil groove and oil holes; lower bearings do not.

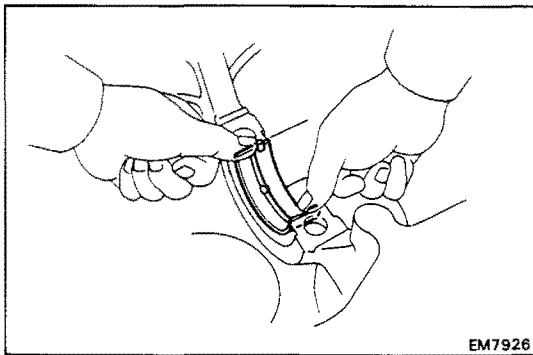
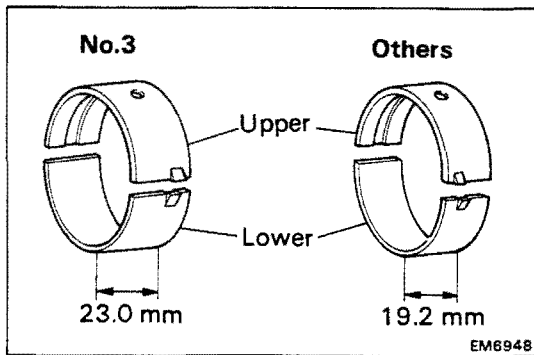

- (a) Align the bearing claw with the claw groove of the cylinder block, and push in the five upper bearings.

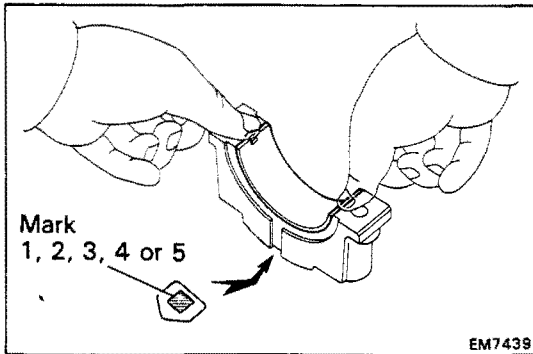

- (b) Align the bearing claw with the claw groove of the main bearing cap, and push in the five lower bearings.

**HINT:** A number is marked on each main bearing cap to indicate the installation position.

**3. INSTALL UPPER THRUST WASHERS**

Install the two thrust washers under the No.3 journal position of the cylinder block with the oil grooves facing outward.

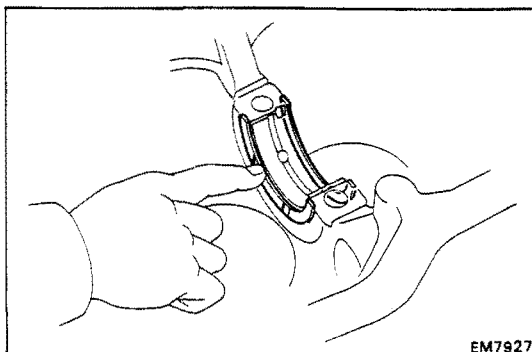

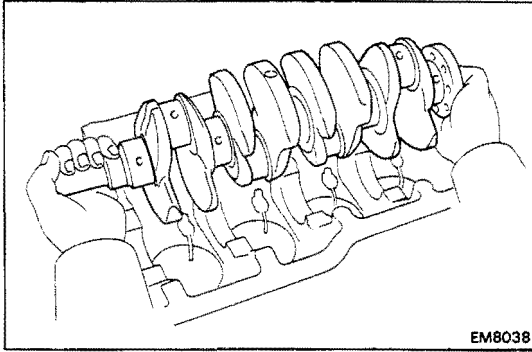

EM8038

#### 4. PLACE CRANKSHAFT ON CYLINDER BLOCK

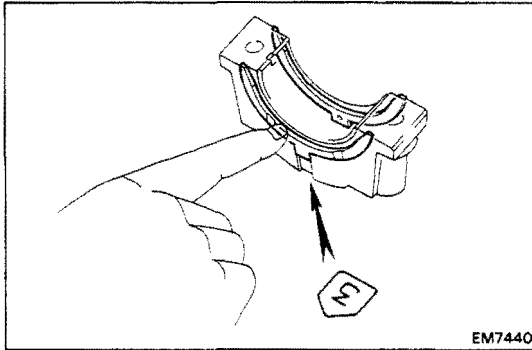

EM7440

#### 5. INSTALL MAIN BEARING CAPS AND LOWER THRUST WASHERS

- (a) Install the two thrust washers on the No.3 bearing cap with the grooves facing outward.

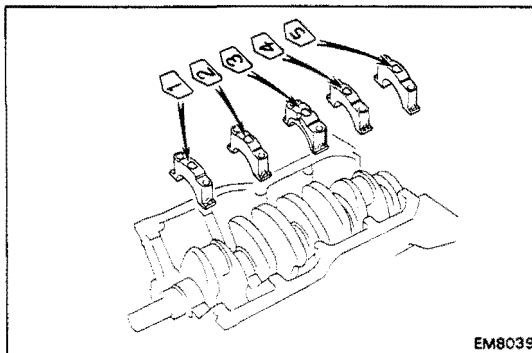

EM8039

- (b) Install the five main bearing caps in their proper locations.

HINT: Each bearing cap has a number and front mark.

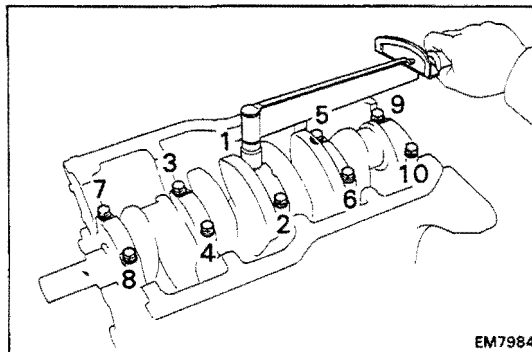

EM7984

- (c) Apply a light coat of engine oil on the threads and under the heads of the main bearing caps.
- (d) Install and uniformly tighten the ten bolts of the main bearing caps in several passes in the sequence shown.

**Torque: 600 kg-cm (43 ft-lb, 59 N·m)**

- (e) Check that the crankshaft turns smoothly.
- (f) Check the crankshaft thrust clearance.  
(See step 5 on page EM-178)

#### 6. INSTALL PISTON AND CONNECTING ROD ASSEMBLIES

- (a) Cover the connecting rod bolts with a short piece of hose to protect the crankshaft from damage.

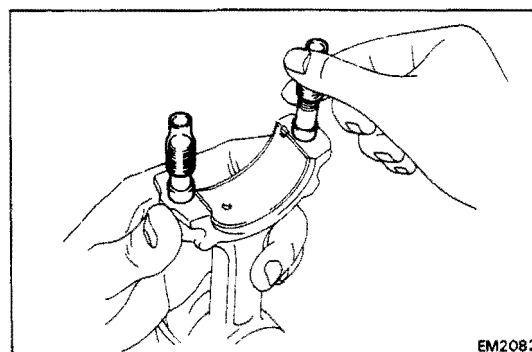

EM2082

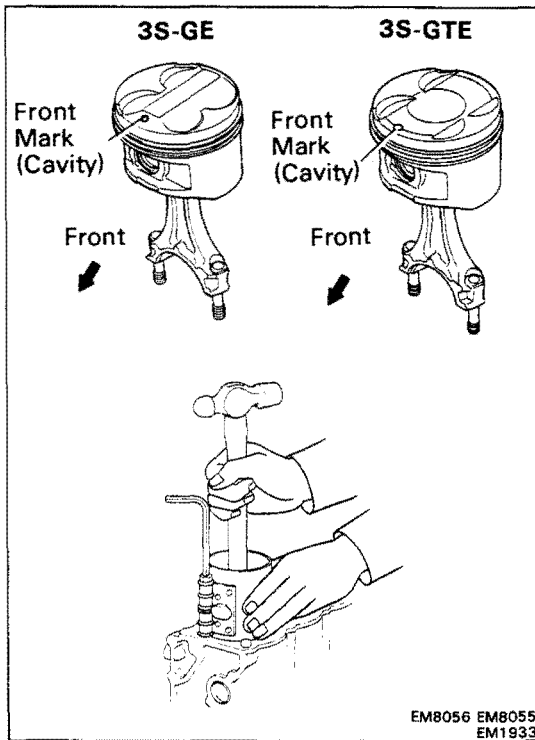

- (b) Using a piston ring compressor, push the correctly numbered piston and connecting rod assemblies into each cylinder with the front mark of the piston facing forward.

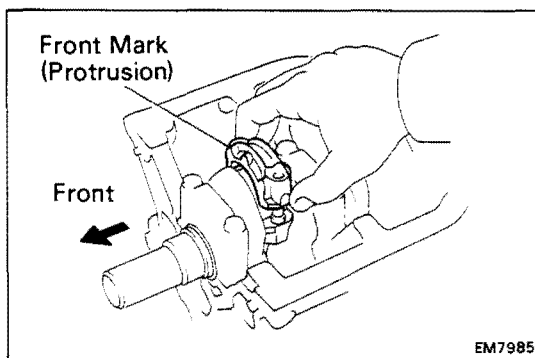

## 7. INSTALL CONNECTING ROD CAPS

- (a) Match the numbered connecting rod cap with the connecting rod.
- (b) Install the connecting rod cap with the front mark facing forward.

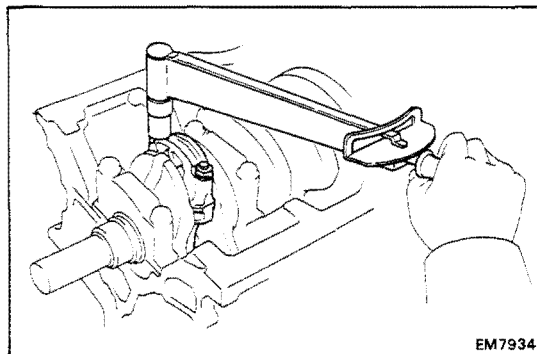

- (c) Apply a light coat of engine oil on the threads and under the cap nuts.
- (d) Using SST, install and alternately tighten the cap nuts in several passes.

**Torque: 680 kg-cm (49 ft-lb, 67 N·m)**

- (e) Check that the crankshaft turns smoothly.
- (f) Check the connecting rod thrust clearance.  
(See step 2 on page EM-176)

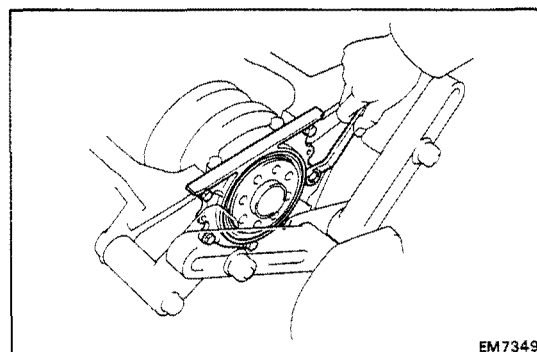

## 8. INSTALL REAR OIL SEAL RETAINER

Install a new gasket and the retainer with the six bolts.

**Torque: 95 kg-cm (82 in.-lb, 9.3 N·m)**

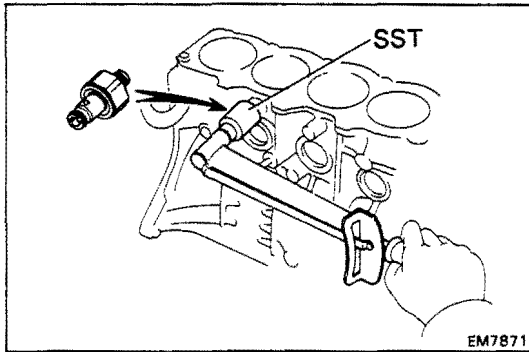

## POST ASSEMBLY

### 1. INSTALL KNOCK SENSOR

Using SST, install the knock sensor.

SST 09816-30010

Torque: 450 kg-cm (33 ft-lb, 44 N·m)

### 2. (w/ OIL COOLER)

**INSTALL OIL COOLER**

3S-GE (See page LU-18)

3S-GTE (See pages LU-21 and 22)

### 3. INSTALL OIL FILTER (See page LU-7)

### 4. INSTALL OIL PUMP AND OIL PAN

(See pages LU-14 and 15)

### 5. INSTALL WATER PUMP AND IDLER PULLEY BRACKET (See pages CO-10 and 11)

### 6. INSTALL CYLINDER HEAD

3S-GE (See pages EM-131 to 137)

3S-GTE (See pages EM-138 to 146)

### 7. INSTALL PULLEYS AND TIMING BELT

(See pages EM-53 to 58)

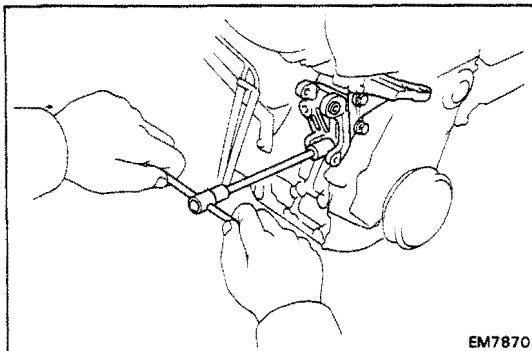

### 8. INSTALL RH ENGINE MOUNTING BRACKET

Install the mounting bracket with the three bolts.

Torque: 530 kg-cm (38 ft-lb, 52 N·m)

### 9. INSTALL PS PUMP BRACKET

Install the PS pump bracket with the three bolts.

Torque: 440 kg-cm (32 ft-lb, 43 N·m)

### 10. REMOVE ENGINE STAND

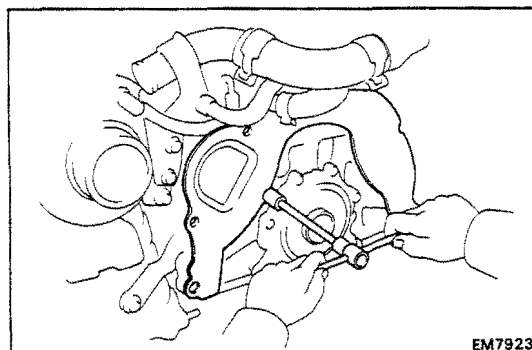

### 11. INSTALL REAR END PLATE

Torque: 95 kg-cm (82 ft-lb, 9.3 N·m)

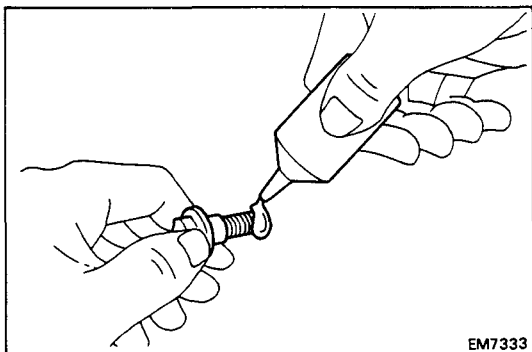

EM7333

**12. (M/T)**  
**INSTALL FLYWHEEL**

- (a) Apply adhesive to two or three threads of the mount bolt end.

**Adhesive: Part No. 08833-00070, THREE BOND 1324 or equivalent**

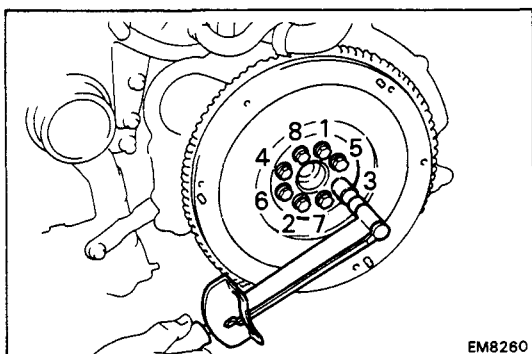

EM8260

- (b) Install the flywheel on the crankshaft.  
(c) Install and uniformly tighten the mount bolts in several passes in the sequence shown.

**Torque: 1,100 kg-cm (80 ft-lb, 108 N·m)**

**14. (A/T)**  
**INSTALL DRIVE PLATE (See procedure step 13)**

**Torque: 850 kg-cm (61 ft-lb, 83 N·m)**

**15. (M/T)**  
**INSTALL CLUTCH DISC AND COVER**



# TURBOCHARGER

	Page
DESCRIPTION .....	TC-2
PRECAUTIONS .....	TC-4
TROUBLESHOOTING .....	TC-5
TURBOCHARGER .....	TC-7

**TC**

## DISCRIPTION

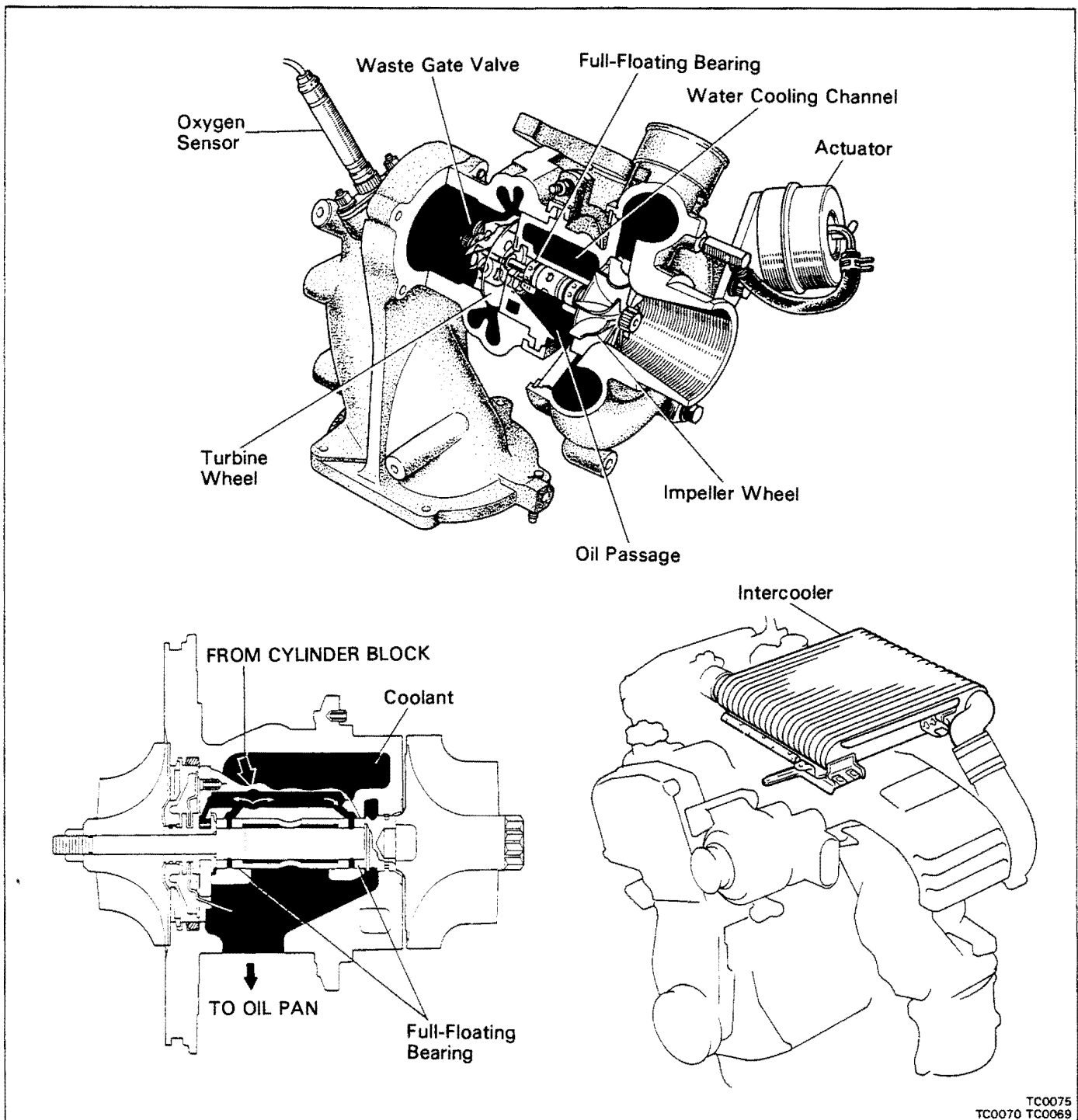
TC0075  
TC0070 TC0069

Systems which increase the amount of air sent to the engine are either turbocharger type (using exhaust gas to turn the turbine) or supercharger type (using the engine crankshaft, etc. to mechanically turn the pump, etc.). For CELICA 3S-GTE engine, the turbocharger type has been adopted.

The turbocharger is a device which increases engine output by sending a greater amount of air-fuel mixture to the engine than under normal conditions.

Engine output depends upon the volume of the air-fuel mixture ignited per unit of time. Therefore, to increase engine output, the most effective method is to send a greater amount of air-fuel mixture into the cylinder.

In other words, by installing a special turbocharger and providing a higher air-fuel mixture than usual, engine output can be increased by increasing the average combustion pressure without increasing the engine speed.

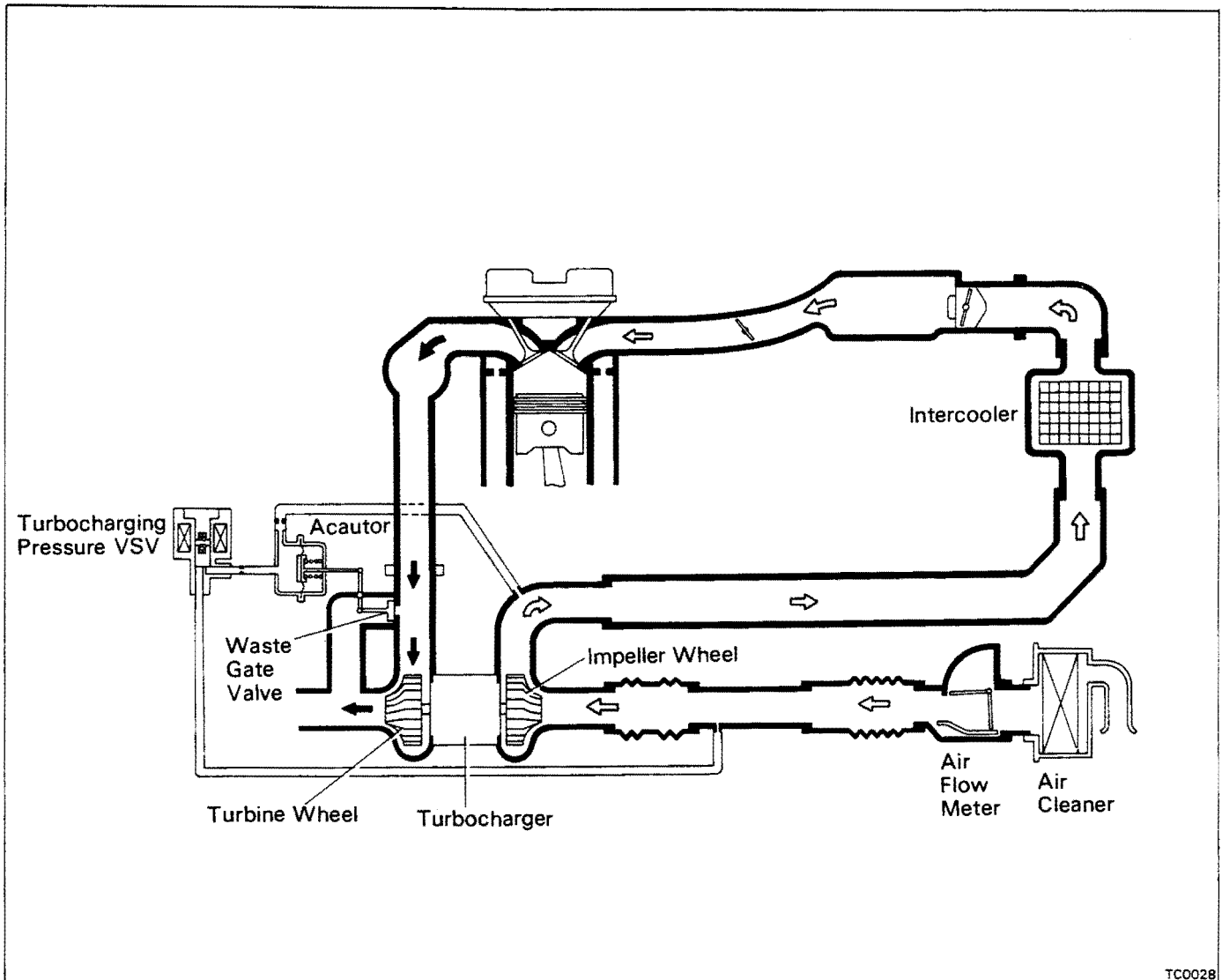

TC0028

### Operation of Turbocharger

Exhaust gas acts on the turbine wheel inside the turbine housing, causing it to revolve. When the turbine wheel revolves, the impeller which is located on the same shaft also revolves, compressing the intake air which has passed through the air flow meter from the air cleaner. When expelled from the compressor housing the compressed air is supplied to the cylinders. When the engine speed increases, the exhaust gas volume increases and the turbine wheel revolutions increase (approx. 20,000 – 110,000 rpm), thus the turbocharged air pressure grows greater and engine output increases.

### Waste Gate Valve

Although on the one hand high output is achieved by turbo-charging, if the turbocharged air pressure becomes too high, knocking occurs and, on the contrary, a reduction in engine output is caused. If the turbocharged air pressure exceeds the prescribed air pressure, the flow of exhaust gas by-passes the turbine, controlling turbine wheel revolutions and turbocharged air pressure. This by-pass valve which controls the quantity of exhaust gas flowing to the turbine is called the waste gate valve. When the turbocharged air pressure exceeds the prescribed pressure, the actuator operates, the waste gate valve opens and part of the exhaust gas by-passes the turbine. This causes a drop in the turbine revolution rate and controls the turbocharged air within the prescribed limits.

### Intercooler

The intercooler cools the turbocharged air (intake air) put out by the turbocharger, thereby increasing the air density. As the intake air temperature decreases, the gas temperature in the combustion chamber falls and the occurrence of knocking is suppressed, giving an increase in engine output.

The Celica 3S-GTE intercooler is an air cooling type located at the top of the engine, utilizing the vehicle windstream to cool the turbocharged air.

## DISCRIPTION

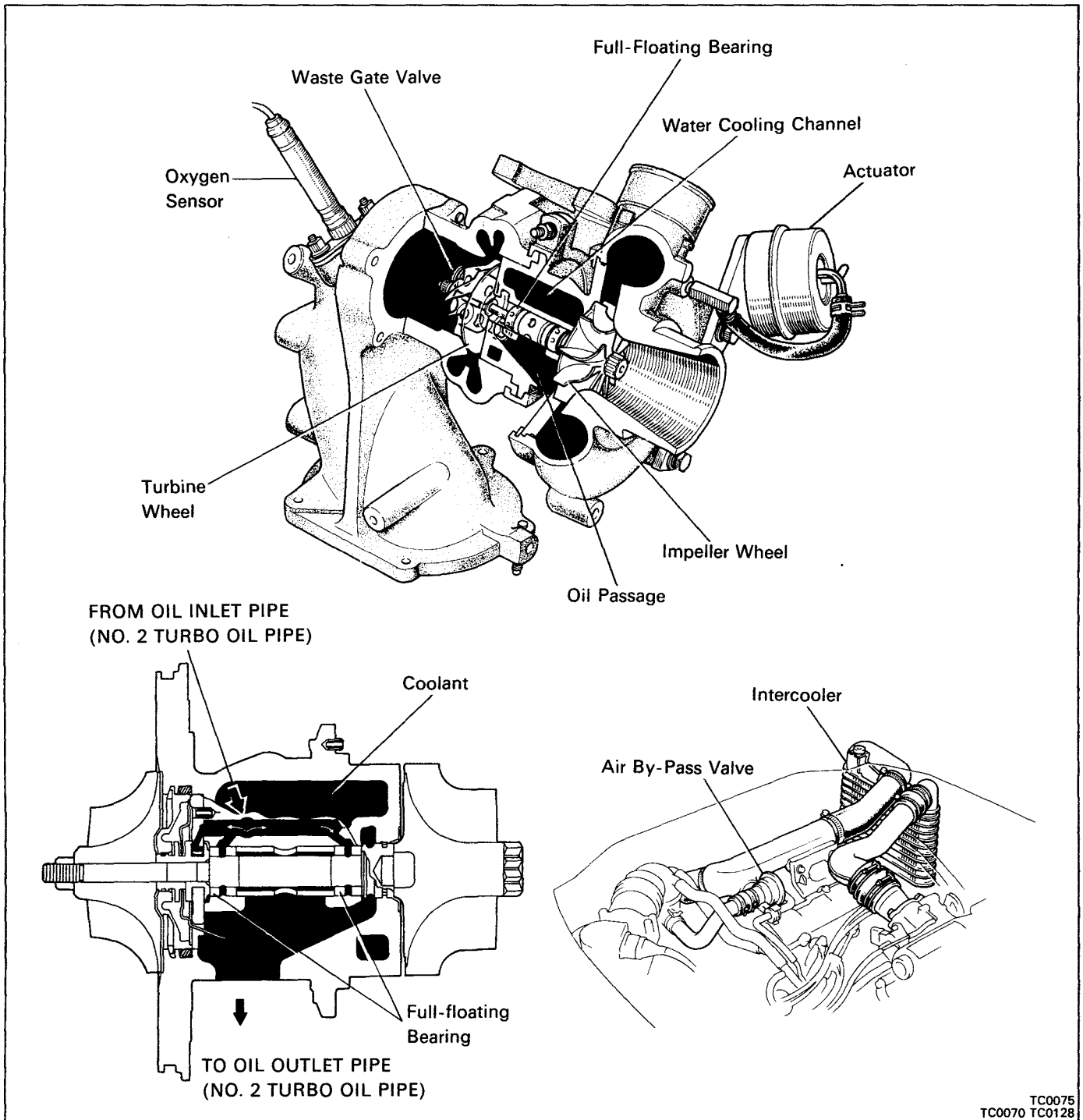

Systems which increase the amount of air sent to the engine are either turbocharger type (using exhaust gas to turn the turbine) or supercharger type (using the engine crankshaft, etc. to mechanically turn the pump, etc.). For MR2 3S-GTE engine, the turbocharger type has been adopted.

The turbocharger is a device which increases engine output by sending a greater amount of air-fuel mixture to the engine than under normal conditions.

Engine output depends upon the volume of the air-fuel mixture ignited per unit of time. Therefore, to increase engine output, the most effective method is to send a greater amount of air-fuel mixture into the cylinder.

In other words, by installing a special turbocharger and providing a higher air-fuel mixture than usual, engine output can be increased by increasing the average combustion pressure without increasing the engine speed.

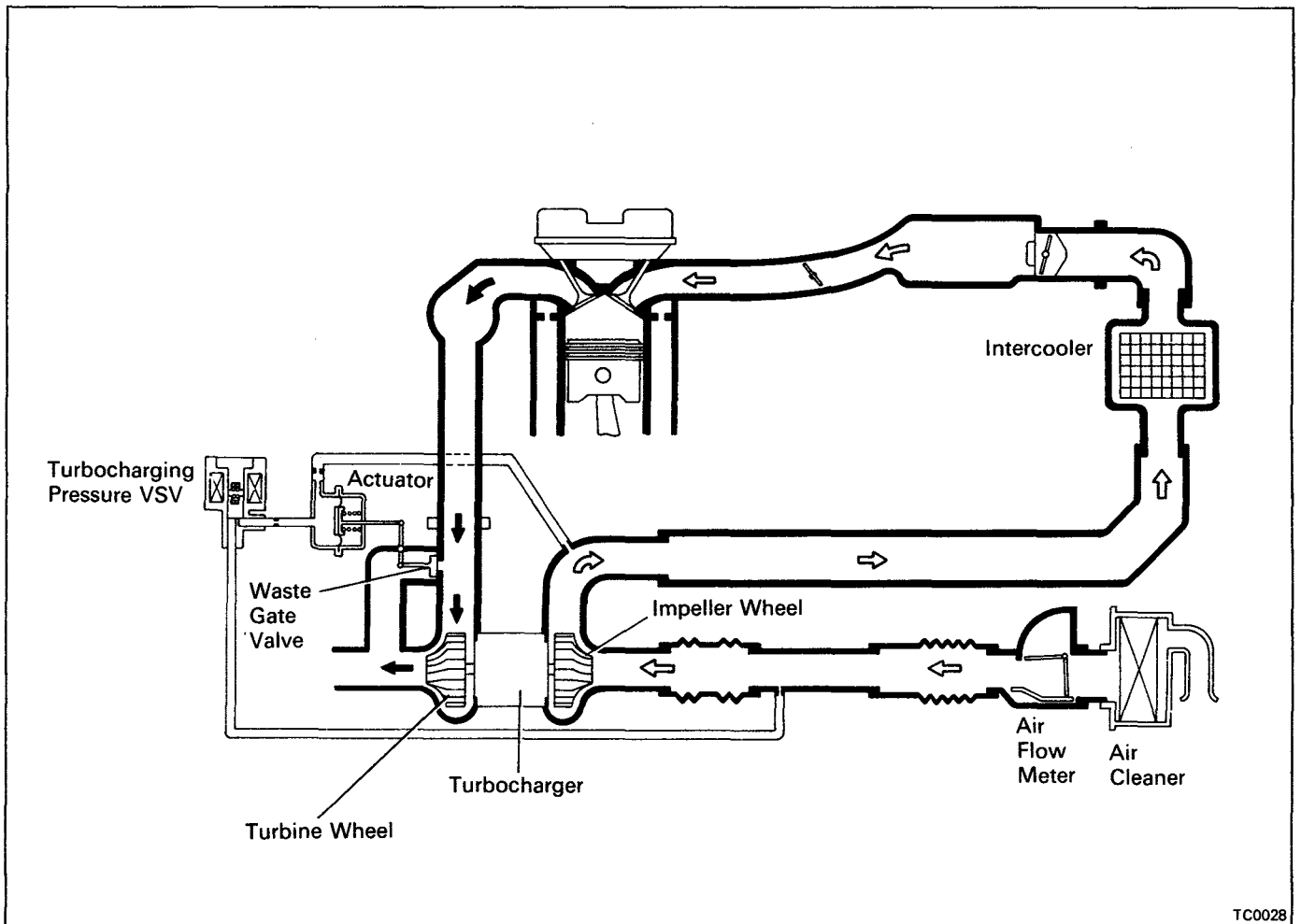

TC0028

### Operation of Turbocharger

Exhaust gas acts on the turbine wheel inside the turbine housing, causing it to revolve. When the turbine wheel revolves, the impeller which is located on the same shaft also revolves, compressing the intake air which has passed through the air flow meter from the air cleaner. When expelled from the compressor housing the compressed air is supplied to the cylinders. When the engine speed increases, the exhaust gas volume increases and the turbine wheel revolutions increase (approx. 20,000 – 110,000 rpm), thus the turbocharged air pressure grows greater and engine output increases.

### Waste Gate Valve

Although on the one hand high output is achieved by turbo-charging, if the turbocharged air pressure becomes too high, knocking occurs and, on the contrary, a reduction in engine output is caused. If the turbocharged air pressure exceeds the prescribed air pressure, the flow of exhaust gas by-passes the turbine, controlling turbine wheel revolutions and turbocharged air pressure. This by-pass valve which controls the quantity of exhaust gas flowing to the turbine is called the waste gate valve. When the turbocharged air pressure exceeds the prescribed pressure, the actuator operates, the waste gate valve opens and part of the exhaust gas by-passes the turbine. This causes a drop in the turbine revolution rate and controls the turbocharged air within the prescribed limits.

### Intercooler

The intercooler cools the turbocharged air (intake air) put out by the turbocharger, thereby increasing the air density. As the intake air temperature decreases, the gas temperature in the combustion chamber falls and the occurrence of knocking is suppressed, giving an increase in engine output.

The Celica MR2 intercooler is an air cooling type located at the top of the engine, utilizing the vehicle windstream to cool the turbocharged air.

## PRECAUTIONS

1. Do not stop the engine immediately after pulling a trailer or high speed or uphill driving. Idle the engine for 20 – 120 seconds, depending on the severity of the driving condition.
2. Avoid sudden racing or acceleration immediately after starting a cold engine.
3. If the engine is run with the air cleaner removed, foreign material entering will damage the wheels which run at extremely high speed.
4. If the turbocharger is defective and must be replaced, first check for the cause of the defect in reference to the following items and replace parts if necessary:
  - Engine oil level and quality
  - Conditions under which the turbocharger was used
  - Oil lines leading to the turbocharger

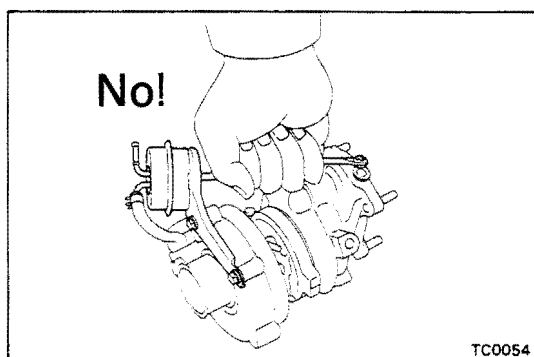

5. Use caution when removing and reinstalling the turbocharger assembly. Do not drop it or bang it against anything or grasp it by easily-deformed parts, such as the actuator or rod, when moving it.
6. Before removing the turbocharger, plug the intake and exhaust ports and oil inlet to prevent entry of dirt or other foreign material.

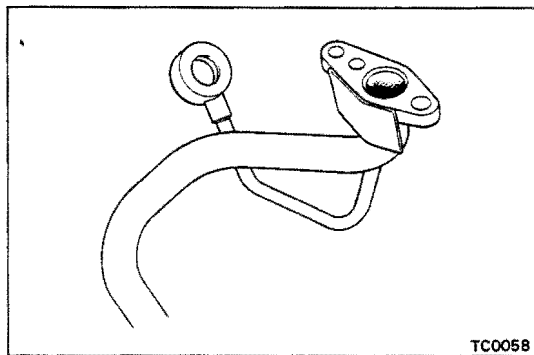

7. If replacing the turbocharger, check for accumulation of sludge particles in the oil pipes, and if necessary, replace the oil pipes.
8. Completely remove the gasket adhered to the lubrication oil pipe flange and turbocharger oil flange.
9. If replacing bolts or nuts, do so only with the specified new ones to guard against breakage or deformation.

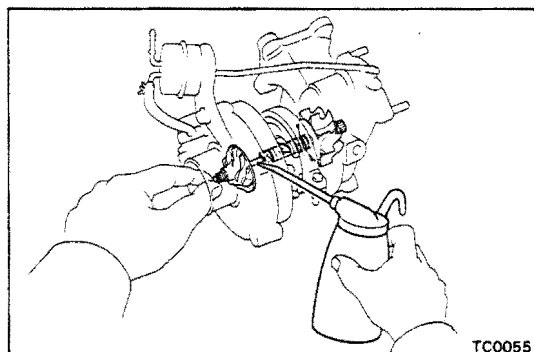

10. If replacing the turbocharger, put 20 cc (1.2 cu in.) of oil into the turbocharger oil inlet and turn the impeller wheel by hand to spread oil to the bearing.
11. If overhauling or replacing the engine, cut the fuel supply after reassembly and crank the engine for 30 seconds to distribute oil to throughout the engine. Then allow the engine to idle for 60 seconds.

## TROUBLESHOOTING

**HINT:** Before troubleshooting the turbocharger, first check the engine itself. (valve clearance, engine compression, ignition timing etc.)

### INSUFFICIENT ACCELERATION, LACK OF POWER OR EXCESSIVE FUEL CONSUMPTION

(Possible Cause)

(Check Procedure and Correction Method)

<p><b>1. TURBOCHARGING PRESSURE TOO LOW</b></p>	<p>Check turbocharging pressure. (See page TC-7)</p> <p><b>Turbocharging pressure:</b>  <b>0.50 – 0.83 kg/cm<sup>2</sup></b>  <b>(7.1 – 11.8 psi, 49 – 81 kPa)</b></p> <p>If the pressure is below specification, begin diagnosis from item 2.</p>
<p><b>2. RESTRICTED INTAKE AIR SYSTEM</b></p>	<p>Check intake air system, and repair or replace parts as necessary. (See page TC-9)</p>
<p><b>3. LEAK IN INTAKE AIR SYSTEM</b></p>	<p>Check intake air system, and repair or replace parts as necessary. (See page TC-9)</p>
<p><b>4. RESTRICTED EXHAUST SYSTEM</b></p>	<p>Check exhaust system, and repair or replace parts as necessary. (See page TC-9)</p>
<p><b>5. LEAK IN EXHAUST SYSTEM</b></p>	<p>Check exhaust system, and repair or replace parts as necessary. (See page TC-9)</p>
<p><b>6. ERRATIC TURBOCHARGER OPERATION</b></p>	<p>Check rotation of impeller wheel. If it does not turn or turns with a heavy drag, replace the turbocharger assembly.</p> <p>Check axial and radial plays of impeller wheel. (See page TC-12)</p> <p><b>Axial play: 0.13 mm (0.0051 in.) or less</b>  <b>Radial play: 0.18 mm (0.0071 in.) or less</b></p> <p>If not within specification, replace the turbocharger assembly.</p>

**ABNORMAL NOISE****(Possible Cause)****(Check Procedure and Correction Method)****1. TURBOCHARGING HEAT INSULATOR  
RESONNANCE**

Check for loose, improperly installed or deformed insulator mount bolts, and repair or replace as necessary.

**2. EXHAUST PIPE LEAKING OR VIBRATING**

Check for deformed exhaust pipe, loose mount bolts or damaged gasket, and repair or replace as necessary.

**3. ERRATIC TURBOCHARGER OPERATION**

Refer to item 6 of INSUFFICIENT ACCELERATION, LACK OF POWER OR EXCESSIVE FUEL CONSUMPTION.

**EXCESSIVE OIL CONSUMPTION OR WHITE EXHAUST****(Possible Cause)****(Check Procedure and Correction Method)****FAULTY TURBOCHARGER SEAL**

Check for oil leakage in exhaust system.

- Remove the turbine elbow from the turbocharger and check for excessive carbon deposits on the turbine wheel. Excessive carbon deposits indicated a faulty turbocharger.

Check for oil leakage in intake air system.

- Check for axial and radial plays in impeller wheel, and replace the turbocharger, if necessary.

(See page TC-12)

**Axial play:** 0.13 mm (0.0051 in.) or less

**Radial play:** 0.18 mm (0.0071 in.) or less

**NOTICE:** There is some oil mist from the PCV in the blowby gas so care must be taken not to diagnosis this as an oil leakage from the turbocharger.



# TURBOCHARGER

## ON-VEHICLE INSPECTION OF TURBOCHARGER

### 1. INSPECT INTAKE AIR SYSTEM

Check for leakage or clogging between the air cleaner and turbocharger inlet and between the turbocharger outlet and cylinder head.

- Clogged air cleaner ..... Clean or replace element
- Hoses collapsed or deformed ..... Repair or replace
- Leakage from connections ..... Check each connection and repair
- Cracks in components ..... Check and replace

### 2. INSPECT EXHAUST SYSTEM

Check for leakage or clogging between the cylinder head and turbocharger inlet and between the turbocharger outlet and exhaust pipe.

- Deformed components ..... Repair or replace
- Foreign material in passages ..... Remove
- Leakage from components ..... Repair or replace
- Cracks in components ..... Check and replace

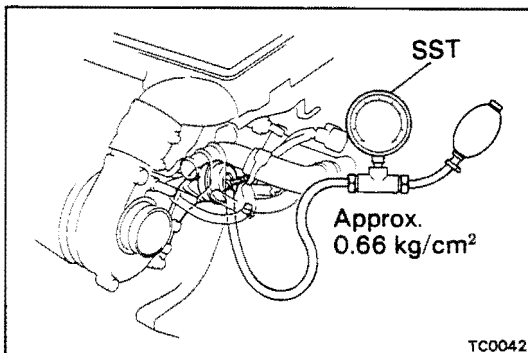

### 3. INSPECT ACTUATOR OPERATION

- (a) Disconnect the actuator hose.
- (b) Using SST (turbocharger pressure gauge), apply approx. 0.66 kg/cm<sup>2</sup> (9.4 psi, 65 kPa) of pressure to the actuator and check that the rod moves.

If the rod does not move, replace the turbocharger assembly.

SST 09992-00241

**NOTICE:** Never apply more than 0.83 kg/cm<sup>2</sup> (11.8 psi, 81 kPa) of pressure to the actuator.

### 4. CHECK TURBOCHARGING PRESSURE

- (a) Using a 3-way connector, connect SST (turbocharger pressure gauge) to the hose leading to the intake manifold.

SST 09992-00241

- (b) While driving with the engine running at 2,800 rpm or more with the throttle valve fully open in the 3rd gear, check the turbocharging pressure.

**Standard pressure:** 0.50 – 0.83 kg/cm<sup>2</sup>  
(7.1 – 11.8 psi, 49 – 81 kPa)

If the pressure is less than that specified, check the intake air and exhaust systems for leakage. If there is no leakage, replace the turbocharger assembly.

If the pressure is above specification, check if the actuator hose is disconnected or cracked. If not, replace the turbocharger assembly.

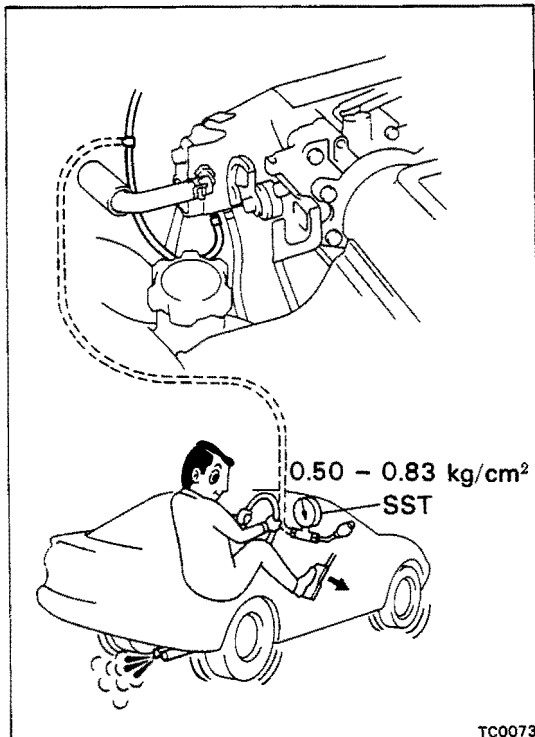

5. INSPECT IMPELLER WHEEL ROTATION  
(See step 1 on page TC-12)
6. INSPECT TURBOCHARGING PRESSURE VSV  
(See page FI-199)
7. INSPECT TURBOCHARGING PRESSURE SENSOR  
(See page FI-198)

COMPONENTS

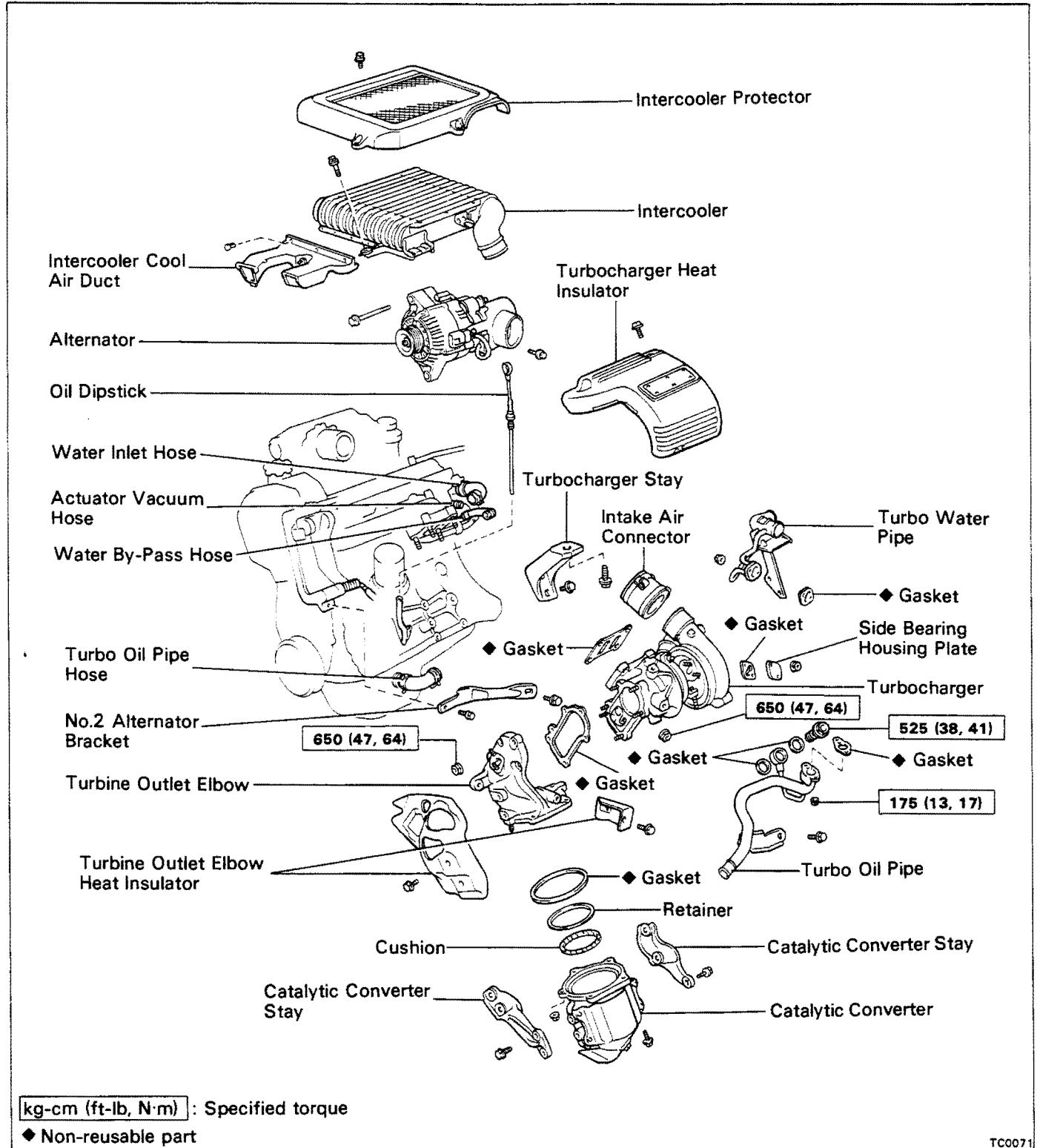

**REMOVAL OF TURBOCHARGER**

1. DRAIN ENGINE COOLANT
2. REMOVE ALTERNATOR  
(See step 3 on page EM-108)
3. REMOVE CATALYTIC CONVERTER  
(See step 5 on page EM-109)

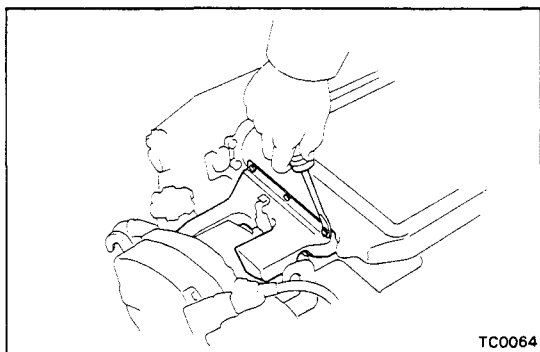

4. REMOVE INTERCOOLER COOL AIR INLET  
Using a clip remover, remove the seven clips and air inlet.

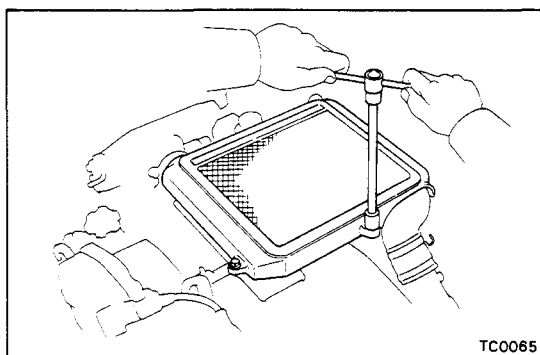

5. REMOVE INTERCOOLER COOL COVER  
Remove the three bolts and intercooler cover.

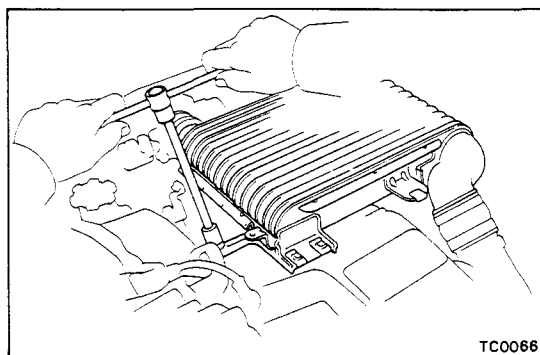

6. REMOVE INTERCOOLER
  - (a) Remove the two bolts.
  - (b) Disconnect the intercooler from the turbocharger and intake air connector, and remove the intercooler and air hose.

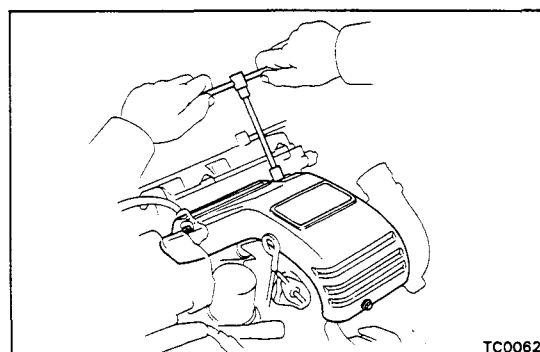

7. REMOVE TURBOCHARGER HEAT INSULATOR  
Remove the three bolts and heat insulator.

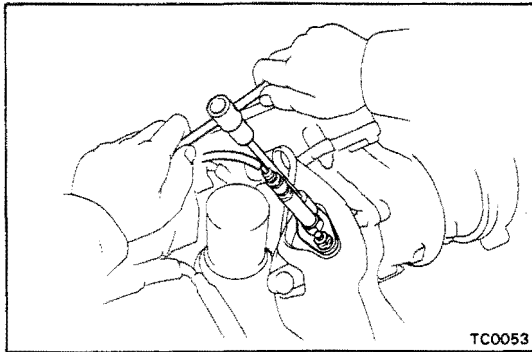

TC0053

**8. REMOVE OXYGEN SENSOR**

- (a) Disconnect the oxygen sensor connector.
- (b) Remove the two nuts, oxygen sensor and gasket.

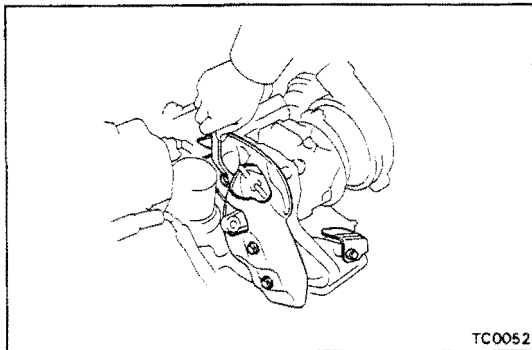

TC0052

**9. REMOVE HEAT INSULATORS OF TURBINE OUTLET ELBOW**

- (a) Remove the oil dipstick.
- (b) Remove the three bolts and RH heat insulator.
- (c) Remove the two bolts and LH heat insulator.

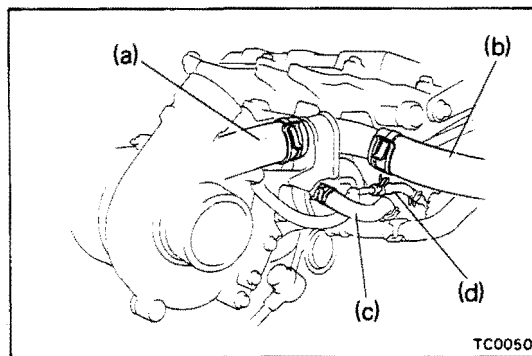

TC0050

**10. DISCONNECT HOSES**

- (a) Water hose from radiator
- (b) Water hose from water inlet
- (c) Water by-pass hose from turbo water pipe
- (d) Vacuum hose from actuator

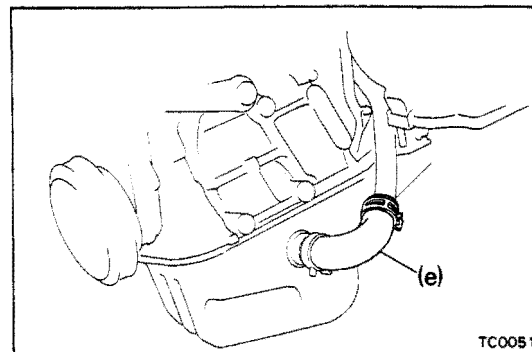

TC0051

- (e) Oil hose from turbo oil pipe

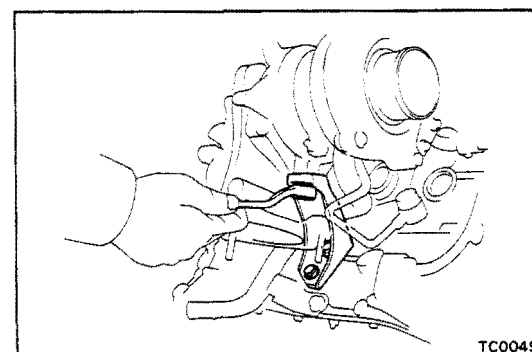

TC0049

**11. REMOVE TURBOCHARGER STAY**

Remove the three bolts and turbocharger stay.

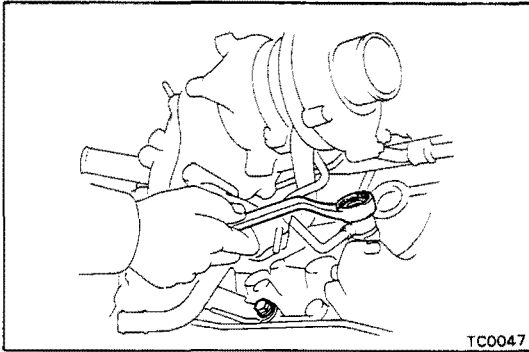
**12. REMOVE TURBOCHARGER**

- (a) Remove the bolt and union bolt holding the No.1 turbo oil pipe to the cylinder block. Remove the two union bolt gaskets

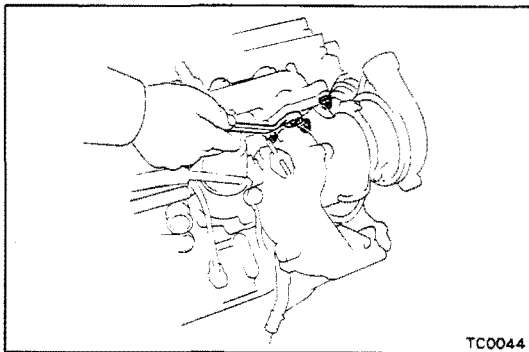

- (b) Remove the four nuts, turbocharger and gasket.

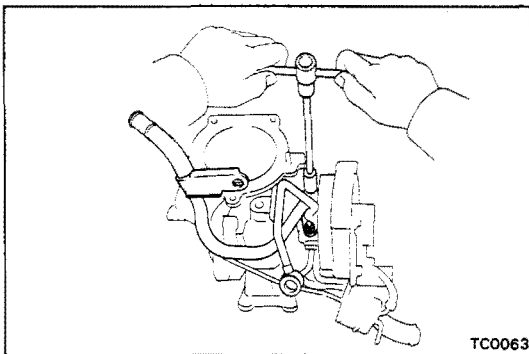
**13. REMOVE TURBO OIL PIPE**

Remove the two nuts, oil pipe and gasket.

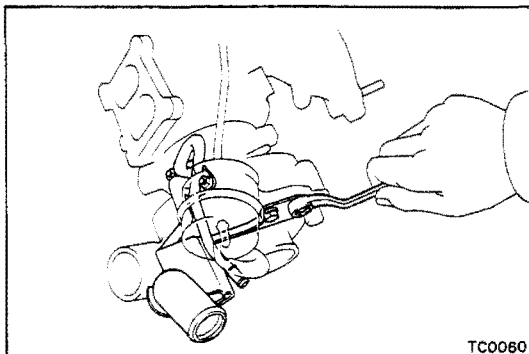
**14. REMOVE TURBO WATER PIPE**

Remove the two nuts, two bolts, water pipe and gasket.

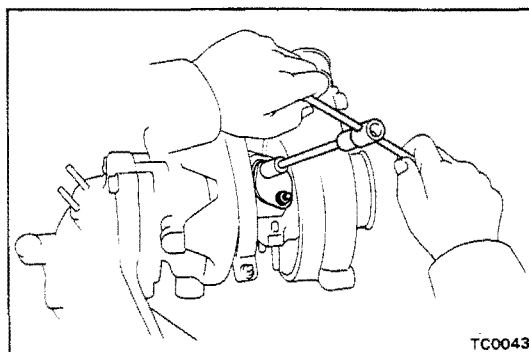
**15. REMOVE SIDE BEARING HOUSING PLATE**

Remove the two nuts, housing plate and gasket.

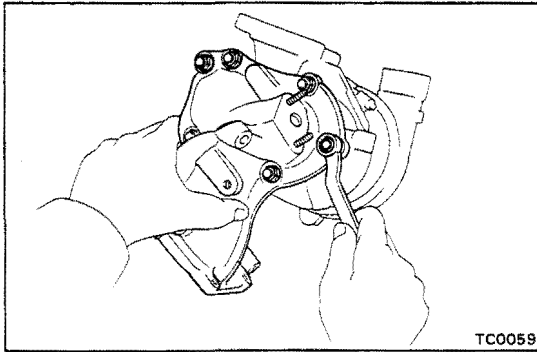

TC0059

**16. REMOVE TURBINE OUTLET ELBOW**

Remove the six nuts, outlet elbow and gasket.

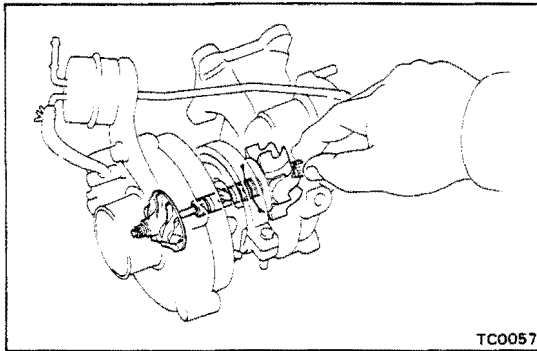

TC0057

**INSPECTION OF TURBOCHARGER**

**1. INSPECT IMPELLER WHEEL ROTATION**

Grasp the edge of the turbine wheel and turn it. Check that the impeller wheel turns smoothly.

If the impeller wheel does not turn or if it turns with a drag, replace the turbocharger assembly.

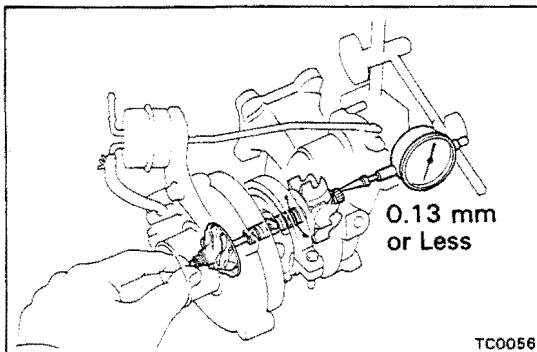

TC0056

**2. INSPECT AXIAL PLAY OF IMPELLER WHEEL**

Insert a dial indicator into the intake side hole the turbine wheel edge by and check the axial play.

**Standard clearance: 0.13 mm (0.0051 in.) or less**

If the axial play is not as specified, replace the turbocharger assembly.

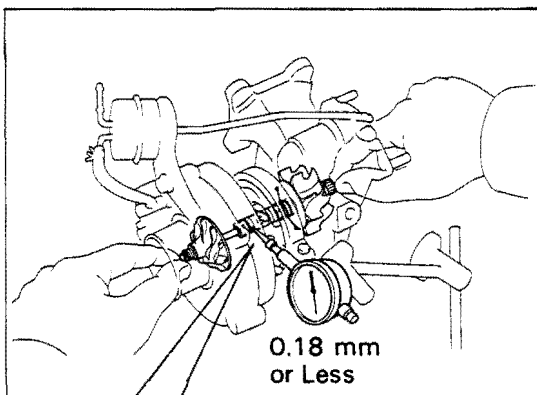

TC0061  
TC0039

**3. INSPECT RADIAL PLAY OF IMPELLER WHEEL**

(a) From oil outlet hole, insert a dial indicator through the hole in the spacer bearing and set it in the center of the impeller shaft.

(b) Move the impeller shaft in a radial direction, measure the radial play of the impeller shaft.

**Standard clearance: 0.18 mm (0.0071 in.) or less**

If the radial play is not as specified, replace the turbocharger assembly.

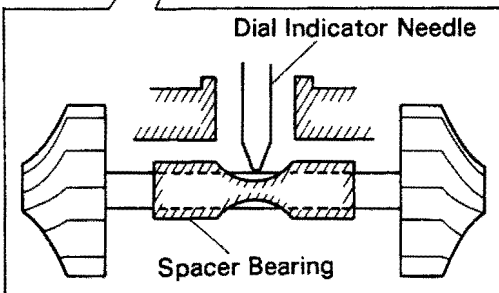

## INSTALLATION OF TURBOCHARGER

(See page TC-8)

**NOTICE:** After replacing the turbocharger assembly, for approx. 20 cc (1.2 cu in.) of new oil into the oil inlet and turn the impeller wheel by hand to splash oil on the bearing.

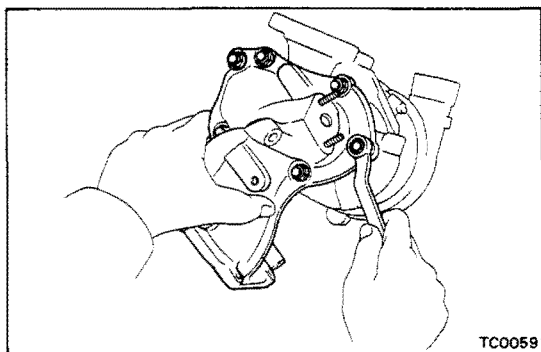

### 1. INSTALL TURBINE OUTLET ELBOW

Install a new gasket and the outlet elbow with the six nuts.

**Torque:** 650 kg-cm (47 ft-lb, 64 N·m)

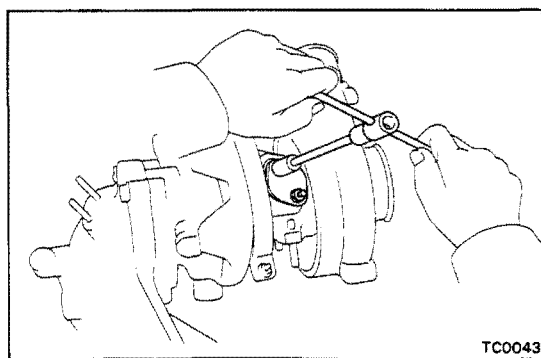

### 2. INSTALL SIDE BEARING HOUSING PLATE

Install a new gasket and the housing plate with the two nuts.

**Torque:** 120 kg-cm (9 ft-lb, 11 N·m)

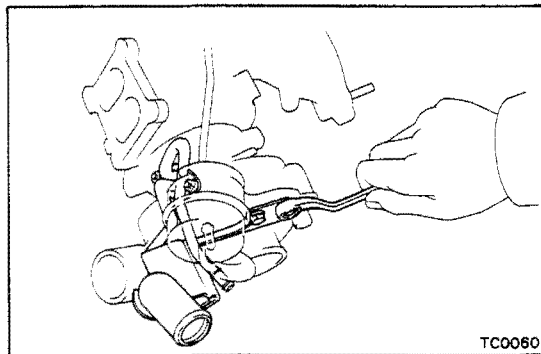

### 3. INSTALL TURBO WATER PIPE

Install a new gasket and the water pipe with the two nuts and two bolts.

**Torque:** 120 kg-cm (9 ft-lb, 11 N·m)

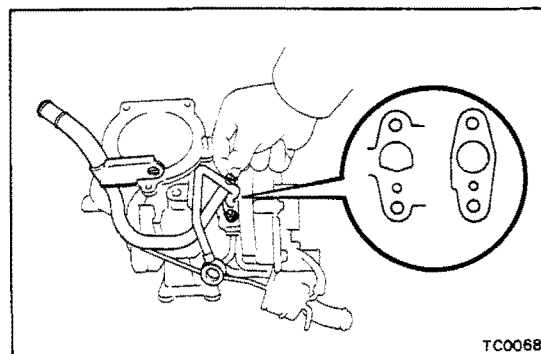

### 4. INSTALL TURBO OIL PIPE

Install a new gasket and the oil pipe with the two nuts. Do not torque the nuts yet.

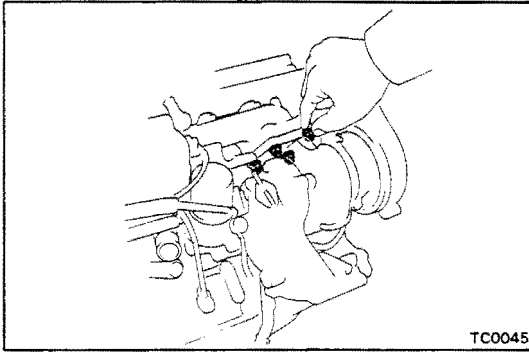

TC0045

## 5. INSTALL TURBOCHARGER

- (a) Install a new gasket and the turbocharger with the four nuts. Do not torque the nuts.

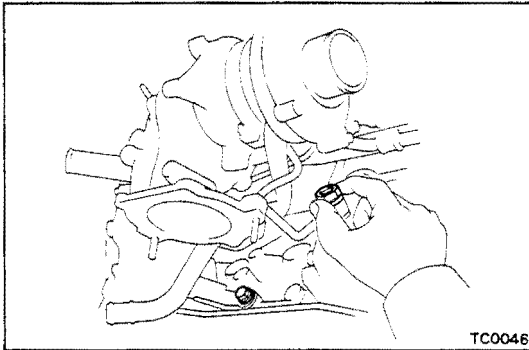

TC0046

- (b) Install the oil pipe with the bolt, two new gaskets and union bolt. Do not torque the bolt and union bolt.

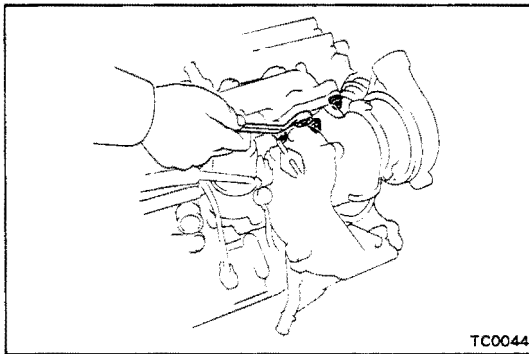

TC0044

- (c) Tighten the four nuts holding the turbocharger to the exhaust manifold.

**Torque: 650 kg-cm (47 ft-lb, 64 N·m)**

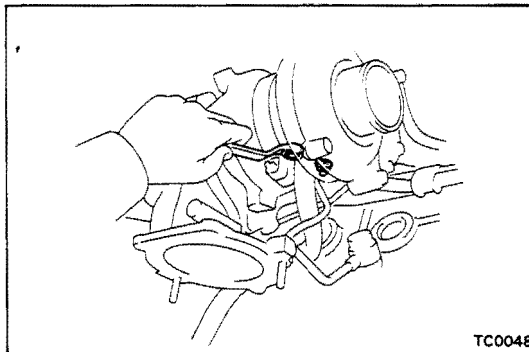

TC0048

- (d) Tighten the two nuts holding the oil pipe to the turbocharger.

**Torque: 175 kg-cm (13 ft-lb, 17 N·m)**

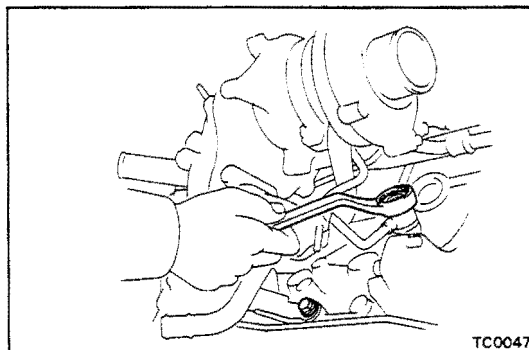

TC0047

- (e) Tighten the union bolt holding the oil pipe to the cylinder block.

**Torque: 525 kg-cm (38 ft-lb, 51 N·m)**

- (f) Tighten the bolt holding the oil pipe to the cylinder block.

**Torque: 440 kg-cm (32 ft-lb, 43 N·m)**



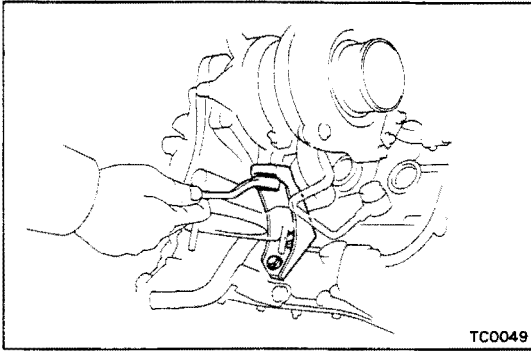

TC0049

**6. INSTALL TURBOCHARGER STAY**

Install the turbocharger stay with the three bolts.

**Torque:**

- To turbocharger 705 kg-cm (51 ft-lb, 69 N·m)
- To cylinder block 600 kg-cm (43 ft-lb, 59 N·m)

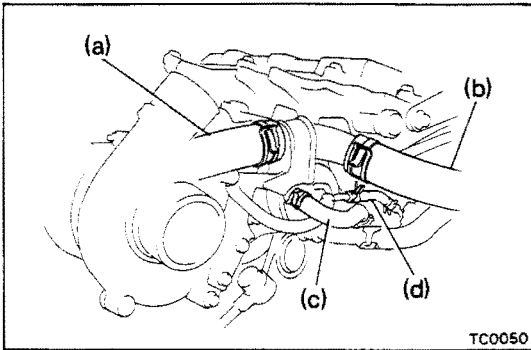

TC0050

**7. CONNECT HOSES**

- (a) Water hose from radiator
- (b) Water hose from water inlet
- (c) Water by-pass hose from turbo water pipe
- (d) Vacuum hose from actuator

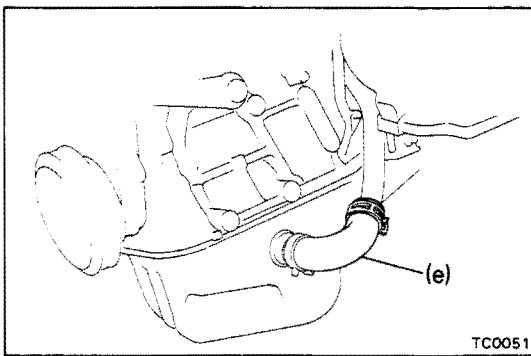

TC0051

- (e) Oil hose from turbo oil pipe

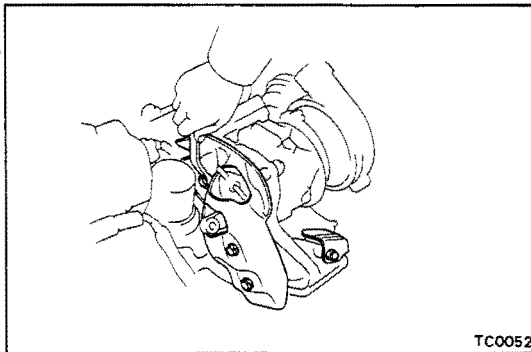

TC0052

**8. INSTALL HEAT INSULATOR OF TURBINE OUTLET ELBOW**

- (a) Install the RH heat insulator with the three bolt.
- (b) Install the LH heat insulator with the two bolt.
- (c) Install the oil dipstick gauge.

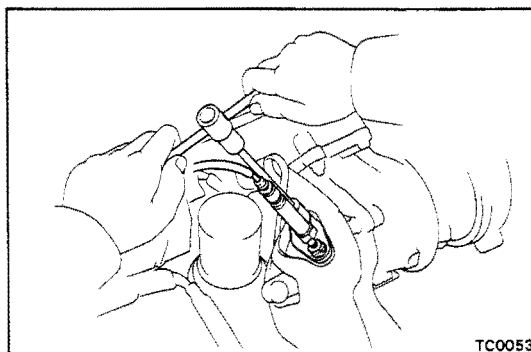

TC0053

**9. INSTALL OXYGEN SENSOR**

- (a) Install a new gaskets and the oxygen sensor with the two nuts.

**Torque: 450 kg-cm (33 ft-lb, 44 N·m)**

- (b) Connect the oxygen sensor connector.

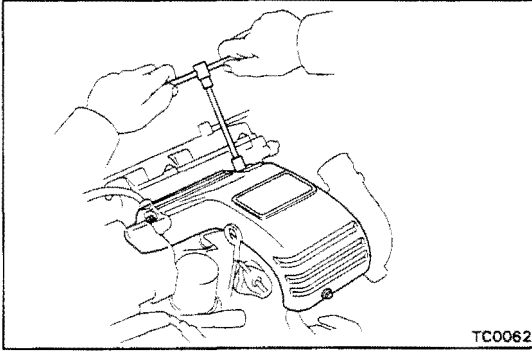
**10. INSTALL TURBOCHARGER HEAT INSULATOR**

Install the heat insulator with the three bolt.

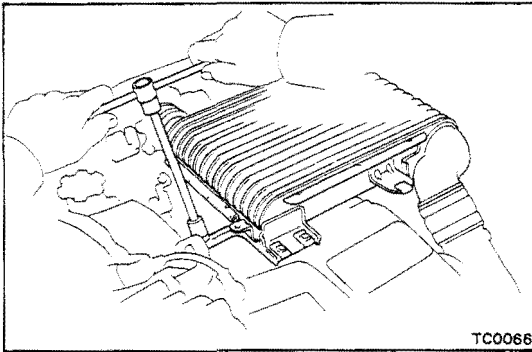
**11. INSTALL INTERCOOLER**

Connect the intercooler to the turbocharger and intake air connector, and install the intercooler with the two bolts.

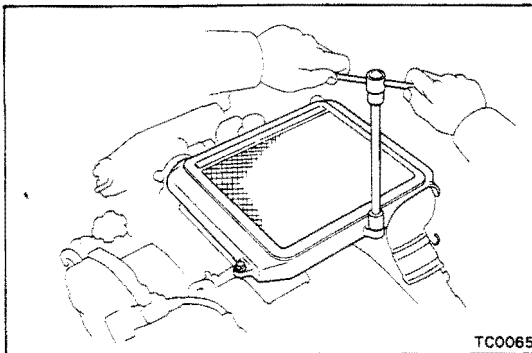
**12. INSTALL INTERCOOLER COVER**

Install the intercooler with the three bolt.

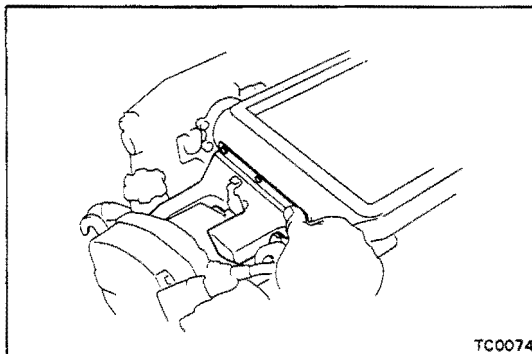
**13. INSTALL INTERCOOLER COOL AIR INLET**

Install the cool air inlet with the seven clips.

**14. INSTALL CATALYTIC CONVERTER**  
(See step 28 on page EM-145)**15. INSTALL ALTERNATOR**  
(See step 30 on page EM-146)**16. FILL ENGINE WITH COOLANT****17. START ENGINE AND CHECK FOR LEAKS****18. CHECK ENGINE OIL LEVEL**

# EFI SYSTEM

	Page
SYSTEM DESCRIPTION .....	FI-2
PRECAUTIONS .....	FI-6
INSPECTION PRECAUTIONS .....	FI-6
TROUBLESHOOTING .....	FI-12
DIAGNOSIS SYSTEM .....	FI-28
TROUBLESHOOTING WITH VOLT/OHMMETER ...	FI-38
FUEL SYSTEM .....	FI-103
Fuel Pump .....	FI-103
Cold Start Injector (5S-FE) .....	FI-118
Cold Start Injector (3S-GE) .....	FI-121
Cold Start Injector (3S-GTE) .....	FI-124
Fuel Pressure Regulator (5S-FE) .....	FI-127
Fuel Pressure Regulator (3S-GE) .....	FI-129
Fuel Pressure Regulator (3S-GTE) .....	FI-131
Injectors (5S-FE) .....	FI-134
Injectors (3S-GE) .....	FI-141
Injectors (3S-GTE) .....	FI-150
AIR INDUCTION SYSTEM .....	FI-155
Air Flow Meter .....	FI-155
Throttle Body (5S-FE w/o ECT) .....	FI-157
Throttle Body (5S-FE w/ ECT) .....	FI-163
Throttle Body (3S-GE) .....	FI-165
Throttle Body (3S-GTE) .....	FI-169
Idle Speed Control (ISC) Valve (5S-FE) .....	FI-174
Idle Speed Control (ISC) Valve (3S-GE) .....	FI-176
Idle Speed Control (ISC) Valve (3S-GTE) .....	FI-178
ELECTRONIC CONTROL SYSTEM .....	FI-180
Location of Electronic Control Parts .....	FI-180
EFI Main Relay .....	FI-182
Circuit Opening Relay .....	FI-183
Solenoid Resistor (3S-GTE only) .....	FI-184
Cold Start Injector Time Switch .....	FI-185
Water Temperature Sensor .....	FI-186
Fuel Pump Relay and Resistor (3S-GTE only) ....	FI-187
Intake Air Temperature Sensor (5S-FE and 3S-GE only) .....	FI-188
Vacuum Sensor (5S-FE and 3S-GE only) (Manifold Absolute Pressure Sensor) .....	FI-189
Variable Resistor (3S-GE (w/o TWC)) .....	FI-190
ACIS VSV (3S-GE only) .....	FI-192
T-VIS VSV (3S-GTE only) .....	FI-194
EGR Control VSV (5S-FE and 3S-GTE only) .....	FI-196
Turbocharging Pressure Sensor (3S-GTE only) ..	FI-198
Turbocharging Pressure VSV (3S-GTE only) .....	FI-199
Oxygen Sensor (w/ TWC only) .....	FI-201
Engine (and ECT) Electronic Controlled Unit (ECU) .....	FI-204
Fuel Cut RPM .....	FI-212
Fuel Pressure Control System (3S-GE only) .....	FI-213

# SYSTEM DESCRIPTION

5S-FE

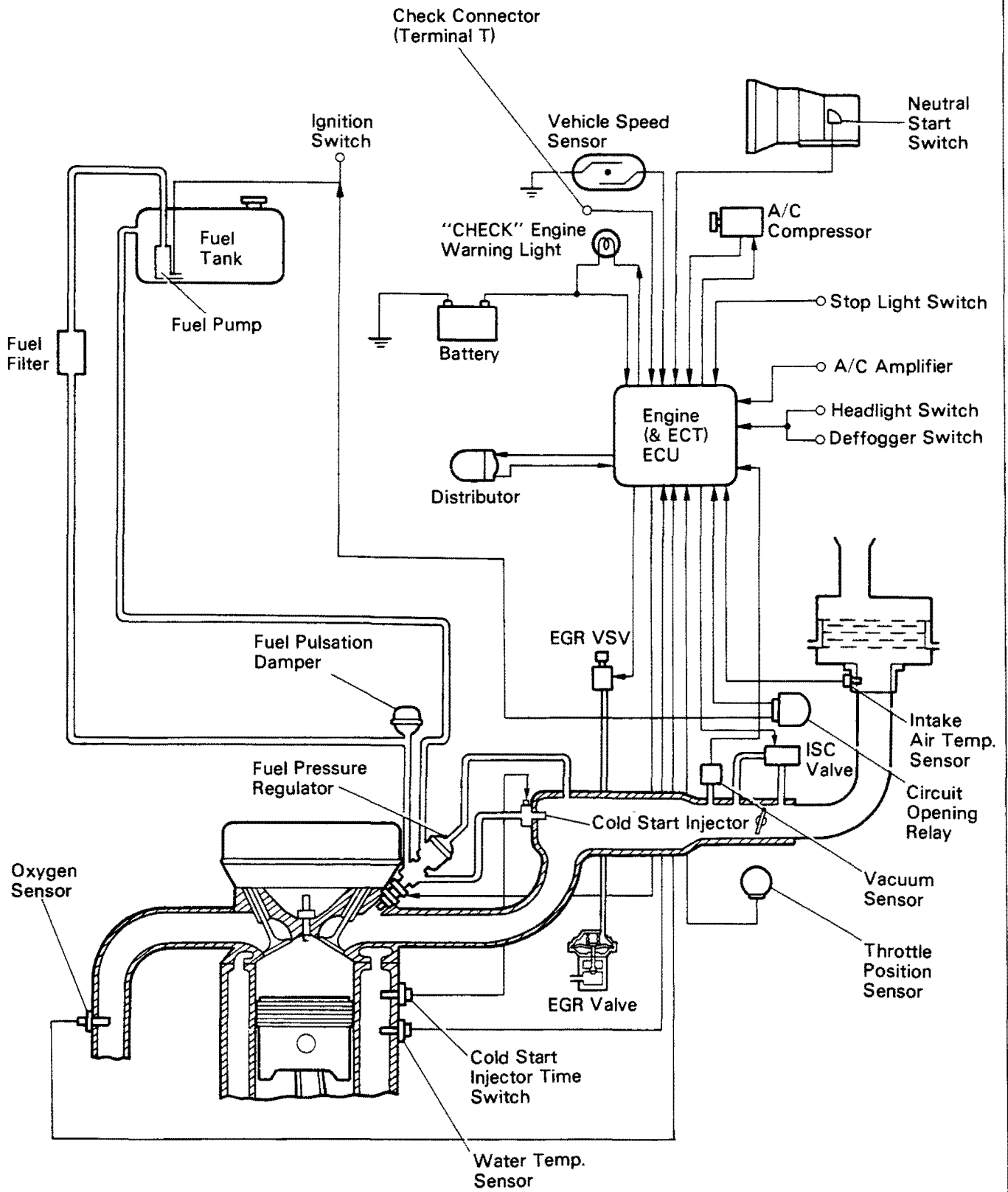

# SYSTEM DESCRIPTION (Cont'd)

3S-GE

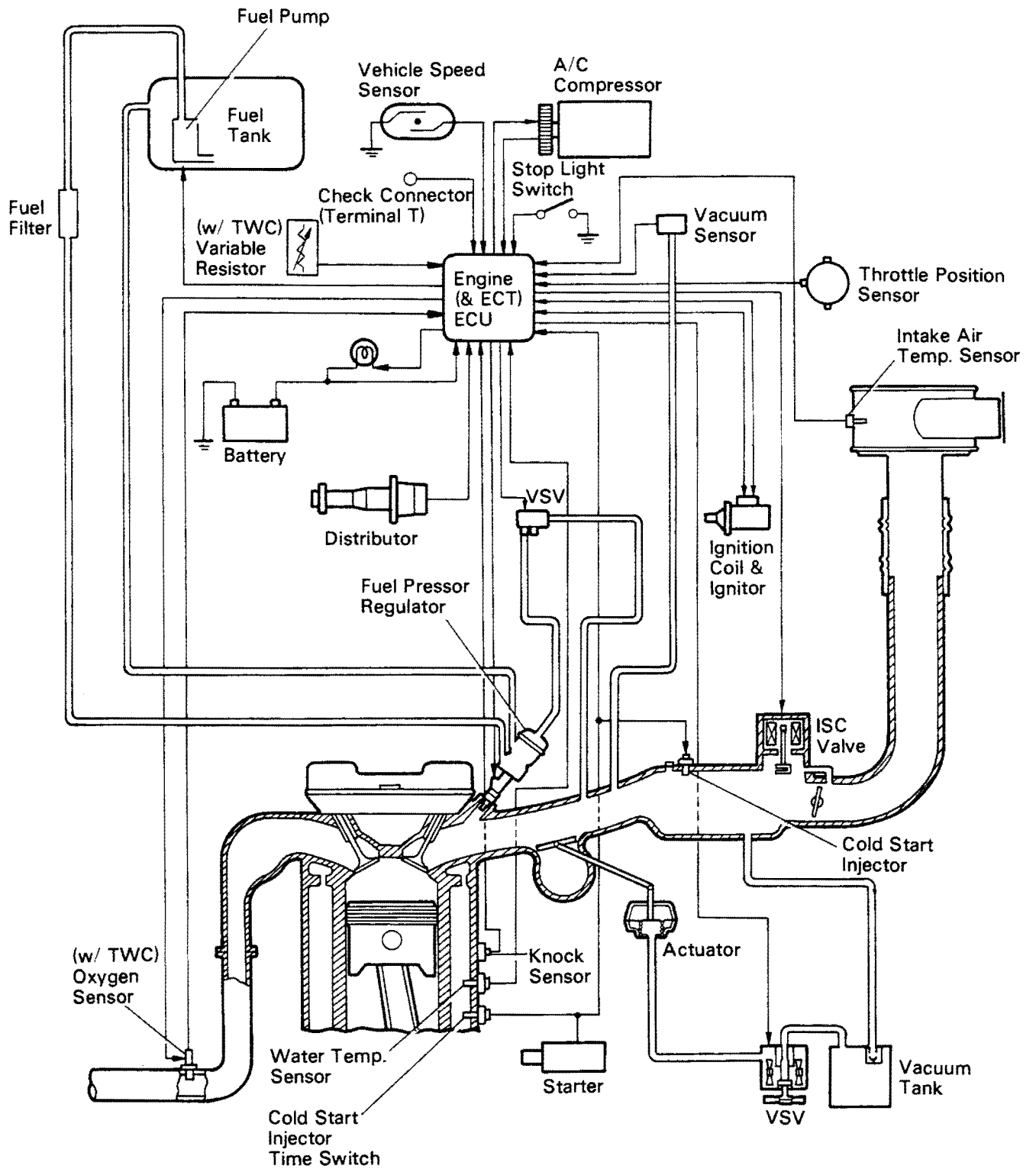

# SYSTEM DESCRIPTION (Cont'd)

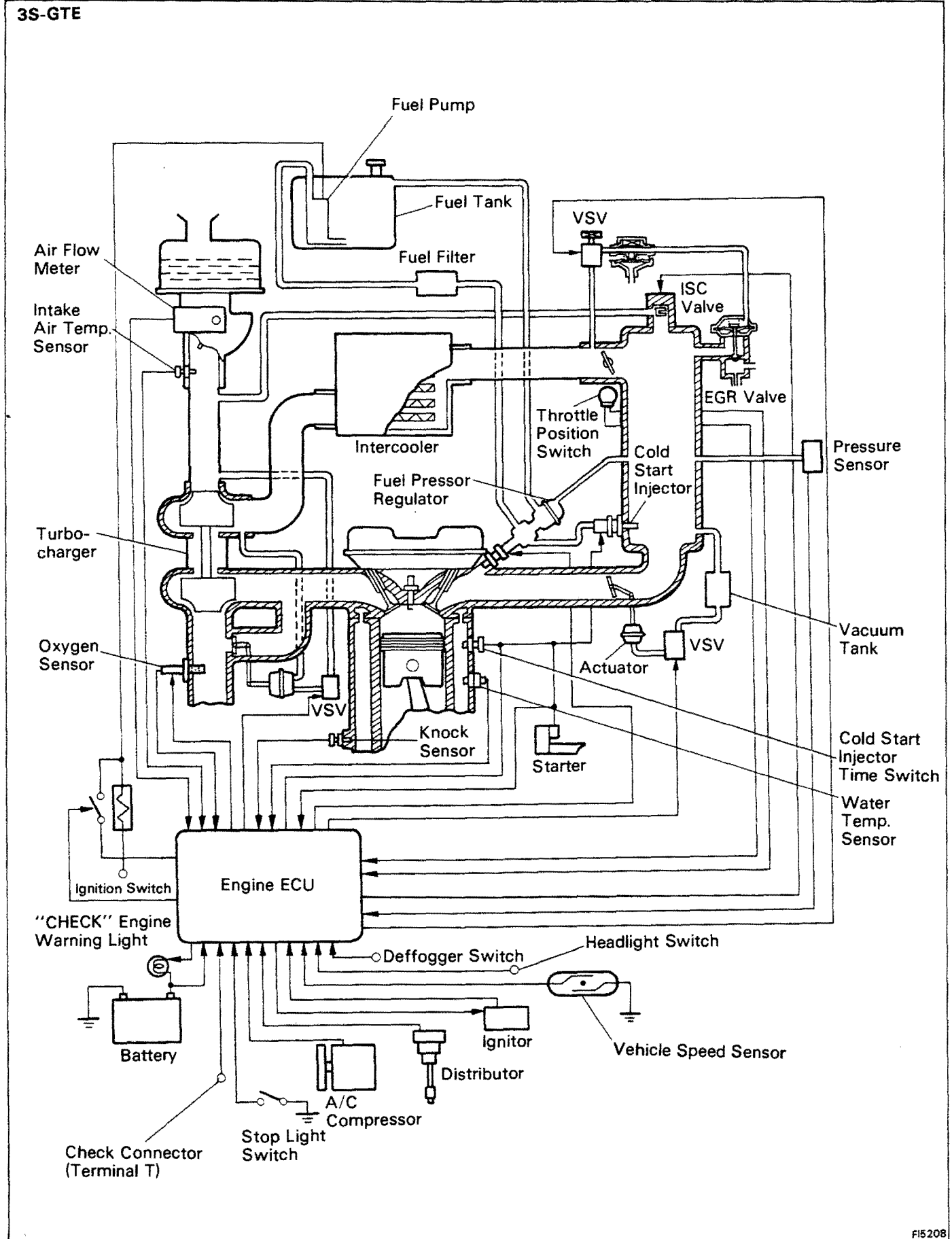

The EFI system is composed of three basic sub-systems: Fuel, Air Induction and Electronic Control Systems.

## FUEL SYSTEM

Fuel is supplied under constant pressure to the EFI injectors by an electric fuel pump. The injectors inject a measured quantity of fuel into the intake ports in accordance with signals from the engine (and ECT) ECU (Electronic Control Unit).

## AIR INDUCTION SYSTEM

The air induction system provides sufficient air for engine operation.

## ELECTRONIC CONTROL SYSTEM

The 5S-FE, 3S-GE and 3S-GTE engines are equipped with a Toyota Computer Control System (TCCS) which centrally controls the EFI, ESA, ISC, Diagnosis systems etc. by means of an Electronic Control Unit (ECU-formerly EFI computer) employing a microcomputer.

By means of the ECU, the TCCS controls the following functions:

### 1. Electronic Fuel Injection (EFI)

The engine (and ECT) ECU receives signals from various sensors indicating changing engine operation conditions such as:

- Intake manifold absolute pressure (5S-FE and 3S-GE)
- Intake air volume (3S-GTE)
- Intake air temperature
- Coolant temperature
- Engine rpm
- Throttle valve opening angle
- Exhaust oxygen content etc.

The signals are utilized by the engine (and ECT) ECU to determine the injection duration necessary for an optimum air-fuel ratio.

### 2. Electronic Spark Advance (ESA)

The engine (and ECT) ECU is programmed with data for optimum ignition timing under any and all operating conditions. Using data provided by sensors which monitor various engine functions (rpm, coolant temperature, etc.), the microcomputer (ECU) triggers the spark at precisely the right instant. (See IG section)

### 3. Idle Speed Control (ISC)

The engine (and ECT) ECU is programmed with target idling speed values to respond to different engine conditions (coolant temperature, air conditioner ON/OFF, etc.). Sensors transmit signals to the engine (and ECT) ECU which control the flow of air through the by-pass of the throttle valve and adjust idle speed to the target value.

### 4. Diagnosis

The engine (and ECT) ECU detects any malfunctions abnormalities in the sensor network and lights a "CHECK" engine warning light on the instrument panel. At the same time, the trouble is identified and a diagnosis code is recorded by the ECU. The diagnosis code can be read by the number of blinks of the "CHECK" engine warning light when terminals TE1 and E1 are connected.

For the diagnostic codes, refer to page FI-31, 33 or 35.

### 5. Fail-Safe Function

In the event of the sensor malfunctioning, a back-up circuit will take over to provide minimal driveability, and the "CHECK" engine warning light will light.

## PRECAUTIONS

1. Before working on the fuel system, disconnect the cable from negative (-) terminal of the battery.  
HINT: Any diagnostic code retained by the computer will be erased when the battery terminal is removed. Therefore, if necessary, read the diagnosis before removing the battery terminal.
2. Do not smoke or work near open flame when working on the fuel system.
3. Keep gasoline off rubber or leather parts.

## INSPECTION PRECAUTIONS

### MAINTENANCE PRECAUTIONS

1. **CHECK CORRECT ENGINE TUNE-UP**  
(See page EM-11)

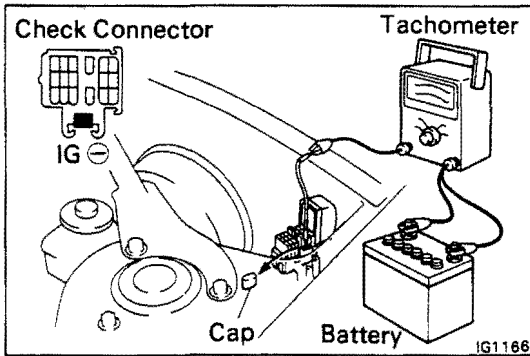

2. **PRECAUTIONS WHEN CONNECTING GAUGE**

- (a) Use the battery as the power source for the timing light, tachometer, etc.
- (b) Connect the test probe of a tachometer to the terminal IG ⊖ of the check connector.

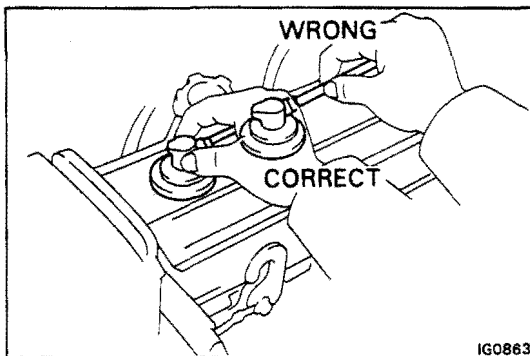

3. **IN THE EVENT OF ENGINE MISFIRE THE FOLLOWING PRECAUTIONS SHOULD BE TAKEN**

- (a) Check proper connection of battery terminals, etc.
- (b) Handle high-tension cords carefully.
- (c) After repair work, check that the ignition coil terminals and all other ignition system lines are reconnected securely.
- (d) When cleaning the engine compartment, be especially careful to protect the electrical system from water.

4. **(w/ TWC) PRECAUTIONS WHEN HANDLING OXYGEN SENSOR**

- (a) Do not allow oxygen sensor to drop or hit against an object.
- (b) Do not allow the sensor to come into contact with water.



## IF VEHICLE IS EQUIPPED WITH MOBILE RADIO SYSTEM (HAM, CB, ETC.)

The engine (and ECT) ECU has been designed so that it will not be affected by outside interference.

However, if your vehicle is equipped with a CB radio transceiver, etc. (even one with about 10 W output), it may, at times, have an effect upon engine (and ECT) ECU operation, especially if the antenna and feeder are installed nearby.

Therefore, observe the following precautions:

1. Install the antenna as far as possible from the engine (and ECT) ECU. The engine ECU is located under the radio so the antenna should be installed at the rear side of the vehicle.
2. Keep the antenna feeder as far away as possible from the engine (and ECT) ECU wires — at least 20 cm (7.87 in.) — and, especially, do not wind them together.
3. Check that the feeder and antenna are properly adjusted.
4. Do not equip your vehicle with a powerful mobile radio system.
5. Do not open the cover or the case of the engine (and ECT) ECU unless absolutely necessary. (If the IC terminals are touched, the IC may be destroyed by static electricity.)

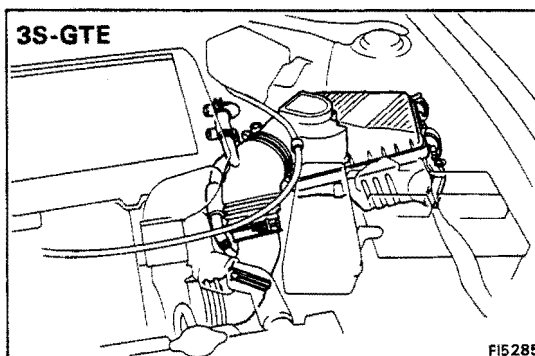
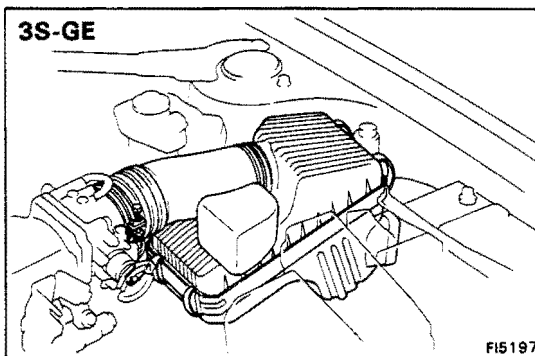
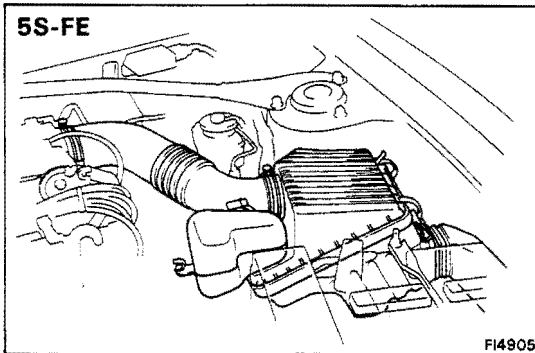
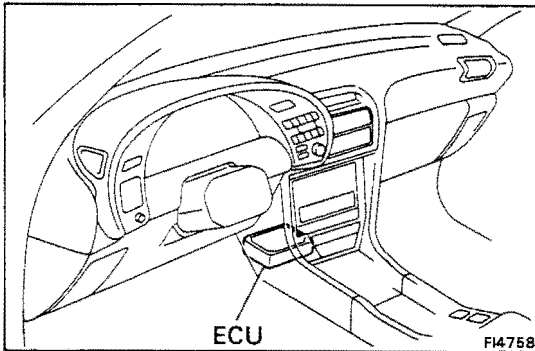

## AIR INDUCTION SYSTEM

1. Separation of the engine oil dipstick, oil filler cap, PCV hose, etc. may cause the engine to run out of tune.
2. Disconnection, looseness or cracks in the parts of the air induction system between the throttle body and cylinder head will cause air suction and cause the engine to run out of tune.

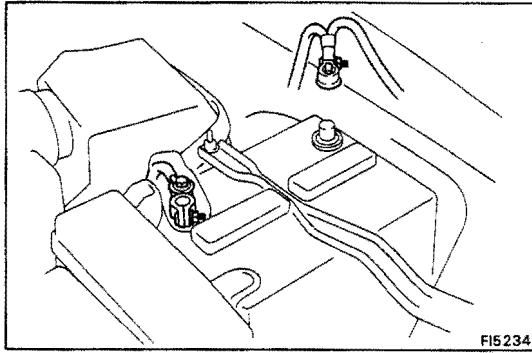

## ELECTRONIC CONTROL SYSTEM

1. Before removing EFI wiring connectors, terminals, etc., first disconnect the power by either turning the ignition switch OFF or disconnecting the battery terminals.

**HINT:** Always check the diagnosis code before disconnecting the battery terminal.

2. When installing the battery, be especially careful not to incorrectly connect the positive (+) and negative (-) cables.
3. Do not permit parts to receive a severe impact during removal or installation. Handle all EFI parts carefully, especially the engine (and ECT) ECU.
4. Do not be careless during troubleshooting as there are numerous transistor circuits and even a slight terminal contact can cause further troubles.

5. Do not open the engine (and ECT) ECU cover.

6. When inspecting during rainy weather, take care to prevent entry of water. Also, when washing the engine compartment, prevent water from getting on the EFI parts and wiring connectors.

7. Parts should be replaced as an assembly.

8. Care is required when pulling out and inserting wiring connectors.

(a) Release the lock and pull out the connector.  
Pull on the connectors.

(b) Fully insert the connector and check that it is locked.

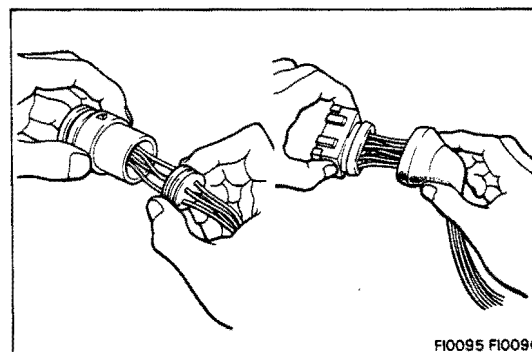
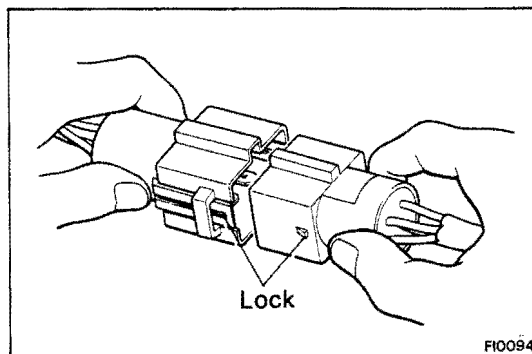
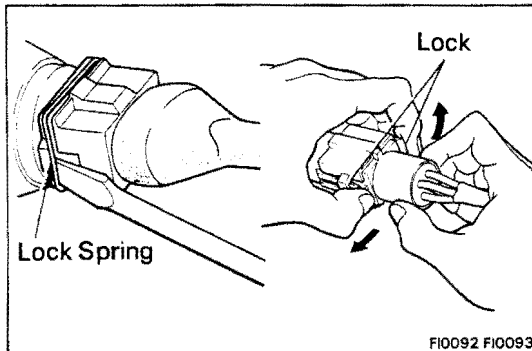

9. When inspecting a connector with a volt/ohmmeter.

(a) Carefully take out the water-proofing rubber if it is a water-proof type connector.

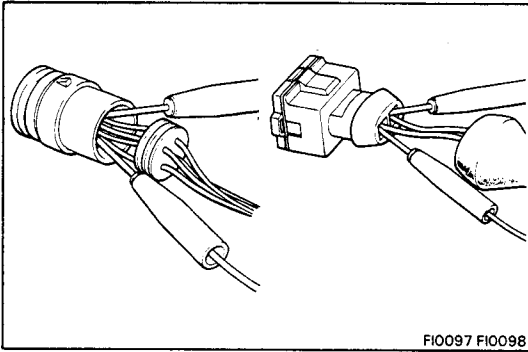

FI0097 FI0098

- (b) Insert the test probe into the connector from wiring side when checking the continuity, amperage or voltage.
- (c) Do not apply unnecessary force to the terminal.
- (d) After checking, install the water-proofing rubber on the connector securely.

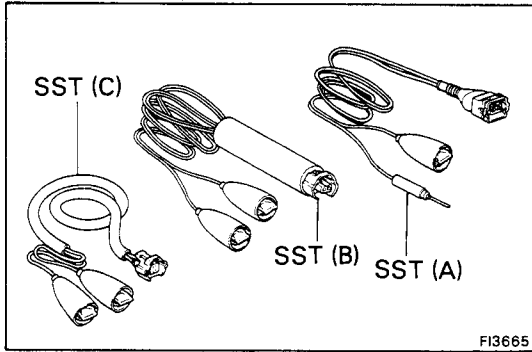

FI3665

10. Use SST for inspection or test of the injector, cold start injector or its wiring connector.

SST 5S-FE and 3S-GE

09842-30050(A) and 09842-30070(C)

3S-GTE 09842-30050(A) and 09842-30060(B)

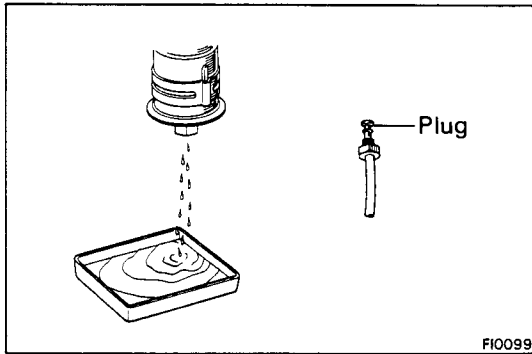

FI0099

### FUEL SYSTEM

1. When disconnecting the high fuel pressure line, a large amount of gasoline will spill out, so observe the following procedure:
  - (a) Put a container under the connection.
  - (b) Slowly loosen the connection.
  - (c) Disconnect the connection.
  - (d) Plug the connection with a rubber plug.

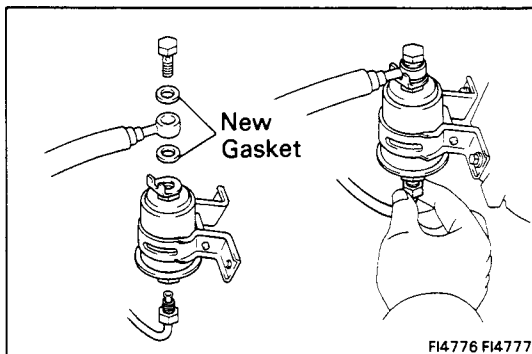

FI4776 FI4777

2. When connecting the flare nut or union bolt on the high pressure pipe union, observe the following procedure:

(Union Bolt Type)

- (a) Always use a new gasket.
- (b) Tighten the union bolt by hand.
- (c) Tighten the union bolt to the specified torque.

**Torque: 300 kg-cm (22 ft-lb, 29 N·m)**

(Flare Nut Type)

- (a) Apply a light coat of engine oil to the flare nut and tighten the flare nut by hand.
- (b) Using SST, tighten the flare nut to the specified torque.

SST 09631-22020

**Torque: 385 kg-cm (28 ft-lb, 38 N·m)**

**HINT:** Use a torque wrench with a fulcrum length of 30 cm (11.81 in.).

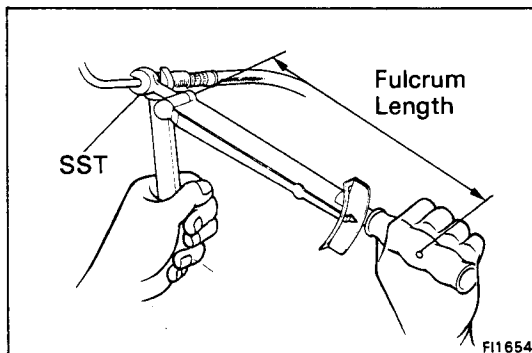

FI1654

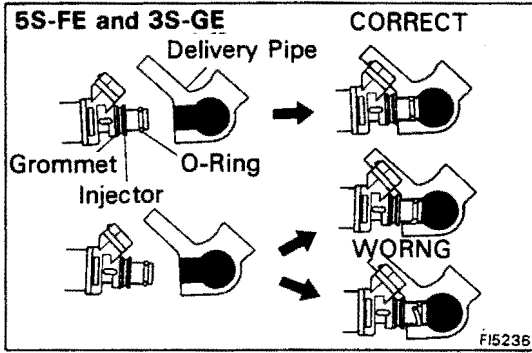

3. Observe the following precautions when removing and installing the injectors.
  - (a) Never reuse the O-ring.
  - (b) When placing a new O-ring on the injector, take care not to damage it in any way.
  - (c) Coat a new O-ring with spindle oil or gasoline before installing — never use engine, gear or brake oil.

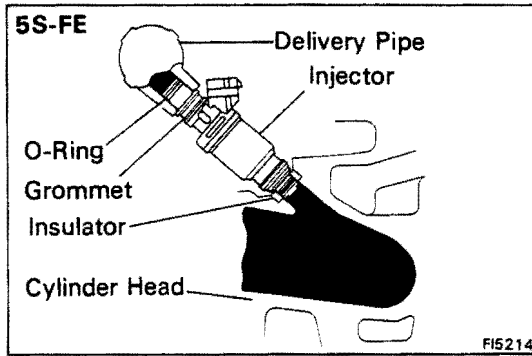
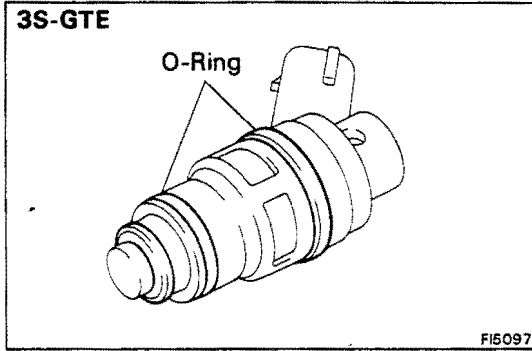

4. Install the injector to delivery pipe and intake manifold as shown in the illustration.

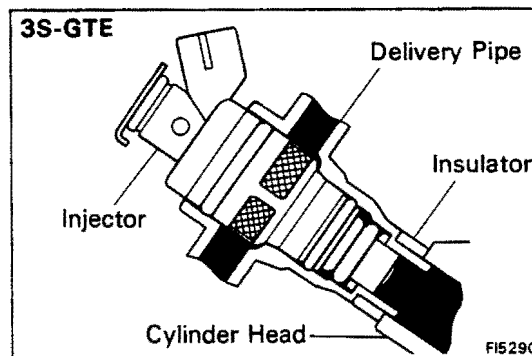
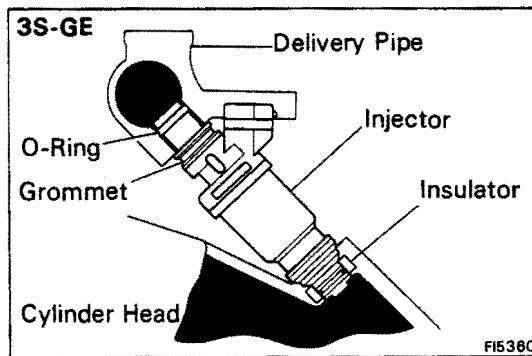

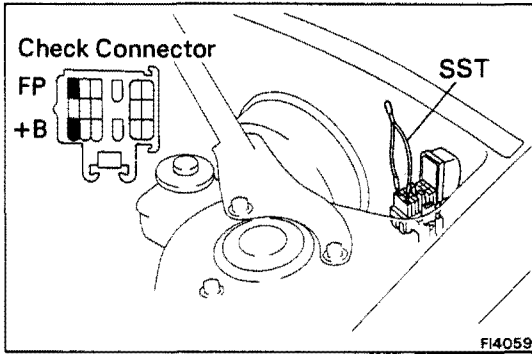

5. Check that there are no fuel leaks after performing any maintenance on the fuel system.
- With engine stopped, turn the ignition switch ON.
  - Using SST, connect terminals +B and FP of the check connector.

SST 09843-18020

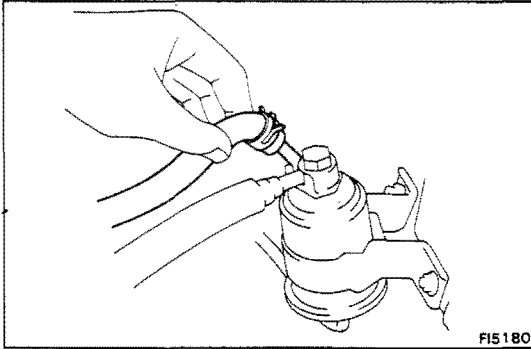

- When the fuel return hose is pinched, the pressure within high pressure line will rise to approx. 4 kg/cm<sup>2</sup> (57 psi, 392 kPa). In this state, check to see that there are no leaks from any part of the fuel system.

**NOTICE:** Always pinch the hose. Avoid bending as it may cause the hose to crack.

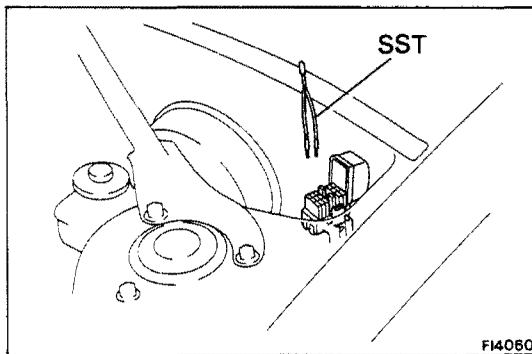

- Remove SST.  
SST 09843-18020

# TROUBLESHOOTING

## TROUBLESHOOTING HINTS

1. Engine troubles are usually not caused by the EFI system. When troubleshooting, always first check the condition of the other systems.
  - (a) Electronic source
    - Battery
    - Fusible links
    - Fuses
  - (b) Body ground
  - (c) Fuel supply
    - Fuel leakage
    - Fuel filter
    - Fuel pump
  - (d) Ignition system
    - Spark plugs
    - High-tension cords
    - Distributor
    - Ignition coil
    - Igniter
  - (e) Air induction system
    - Vacuum leaks
  - (f) Emission control system
    - PCV system
    - EGR system
  - (g) Others
    - Ignition timing (ESA system)
    - Idle speed (ISC system)
    - etc.

2. The most frequent cause of problems is simply a bad contact in wiring connectors. Always check that connections are secure.

When inspecting the connector, pay particular attention to the following points:

- (a) Check to see that the terminals are not bent.
  - (b) Check to see that the connector is pushed in completely and locked.
  - (c) Check to see that there is no signal change when the connector is slightly tapped or wiggled.
3. Troubleshoot sufficiently for other causes before replacing the engine (and ECT) ECU, as the ECU is of high quality and it is expensive.

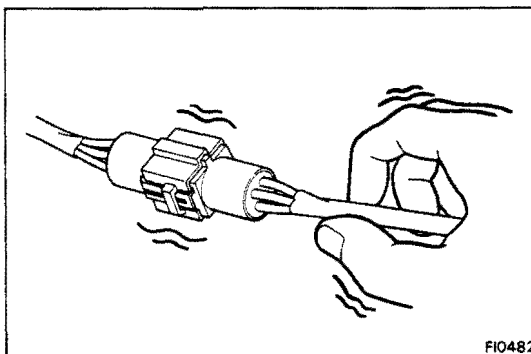
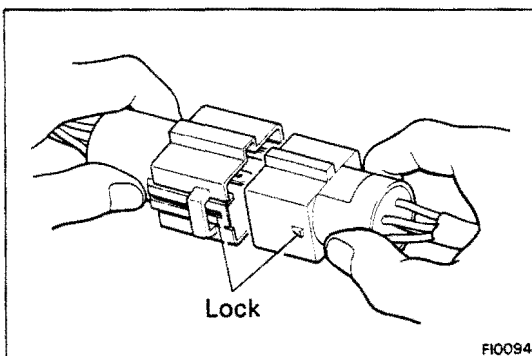

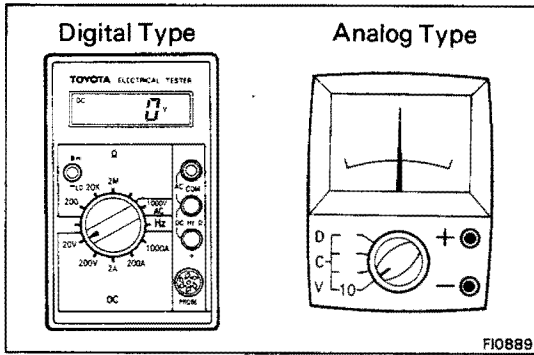

4. Use a volt/ohmmeter with high impedance (10 kΩ/V minimum) for troubleshooting of the electrical circuit. (See page FI-38)

**TROUBLESHOOTING PROCEDURES**

**SYMPTOM – DIFFICULT TO START OR NO START (ENGINE WILL NOT CRANK OR CRANKS SLOWLY)**

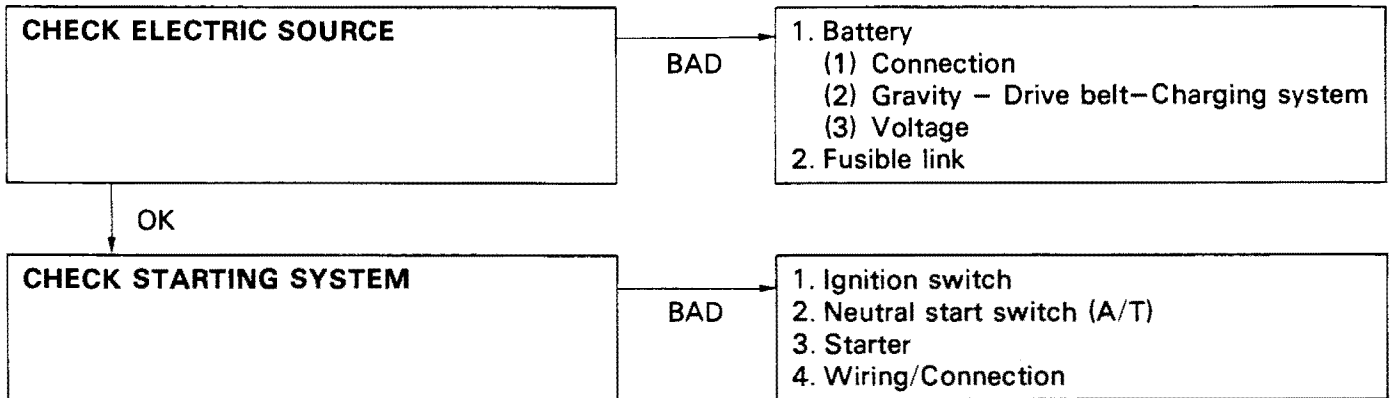

**SYMPTOM — DIFFICULT TO START OR NO START (CRANKS OK)**

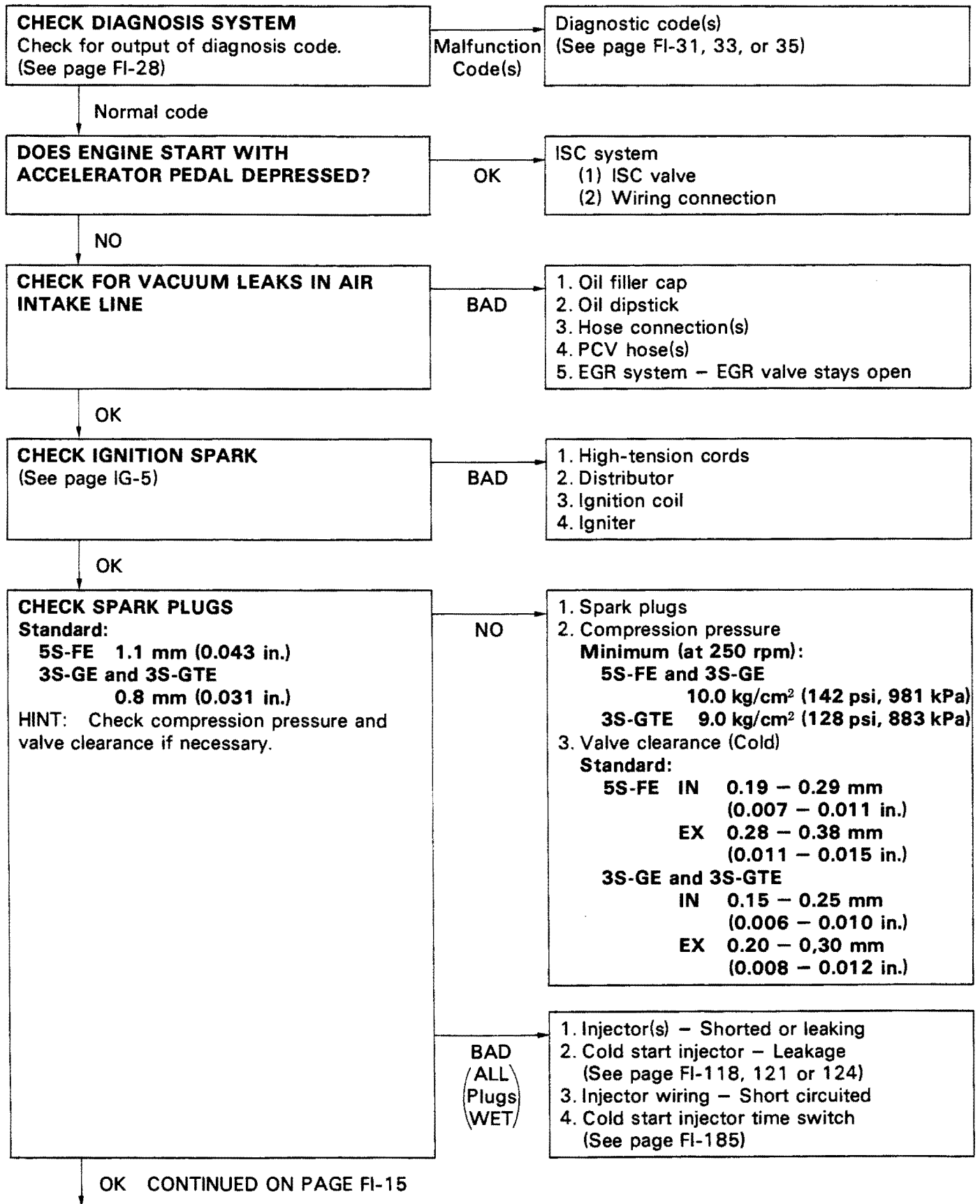



OK CONTINUED FROM PAGE FI-14

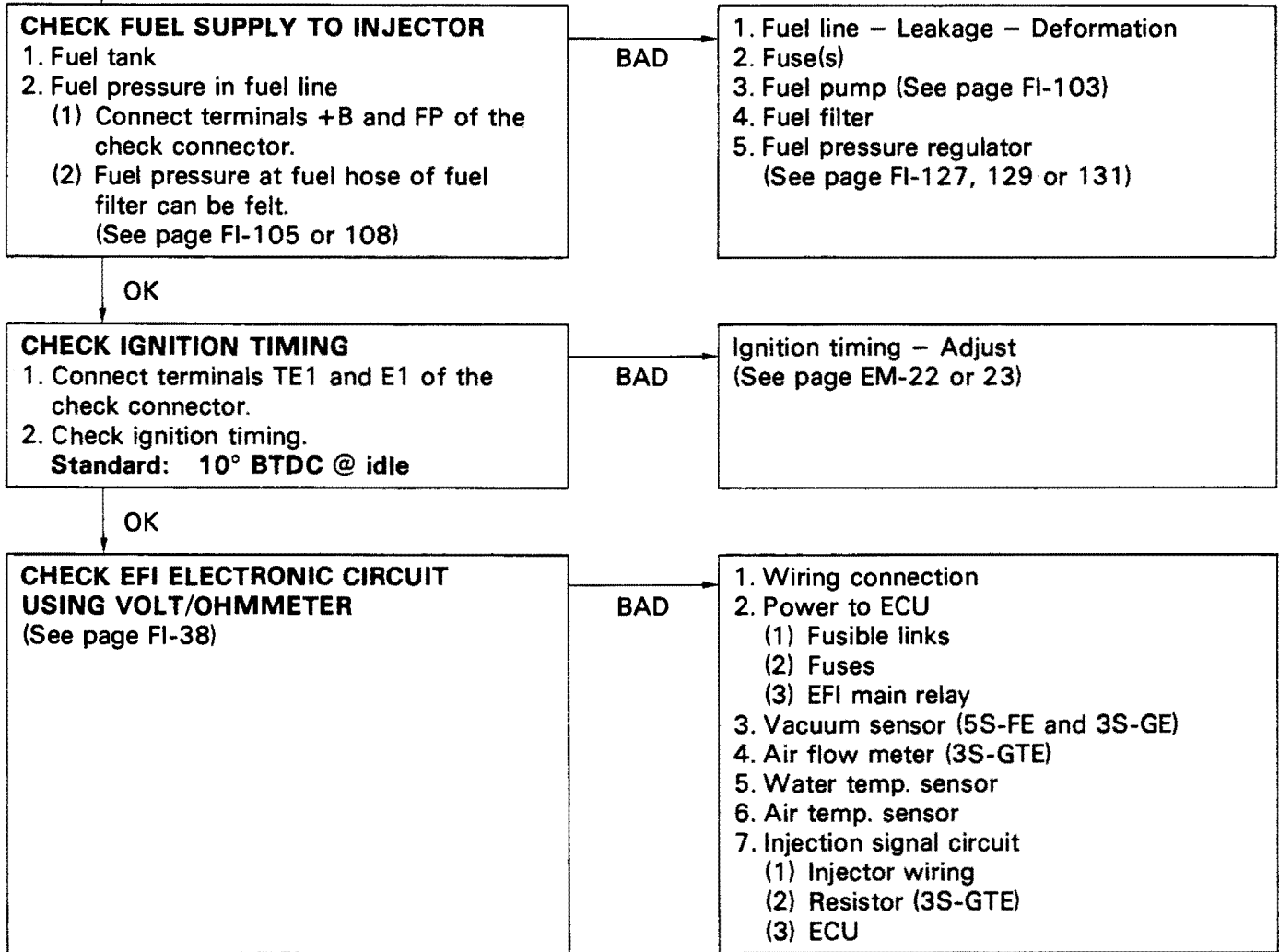

**SYMPTOM – ENGINE OFTEN STALLS**

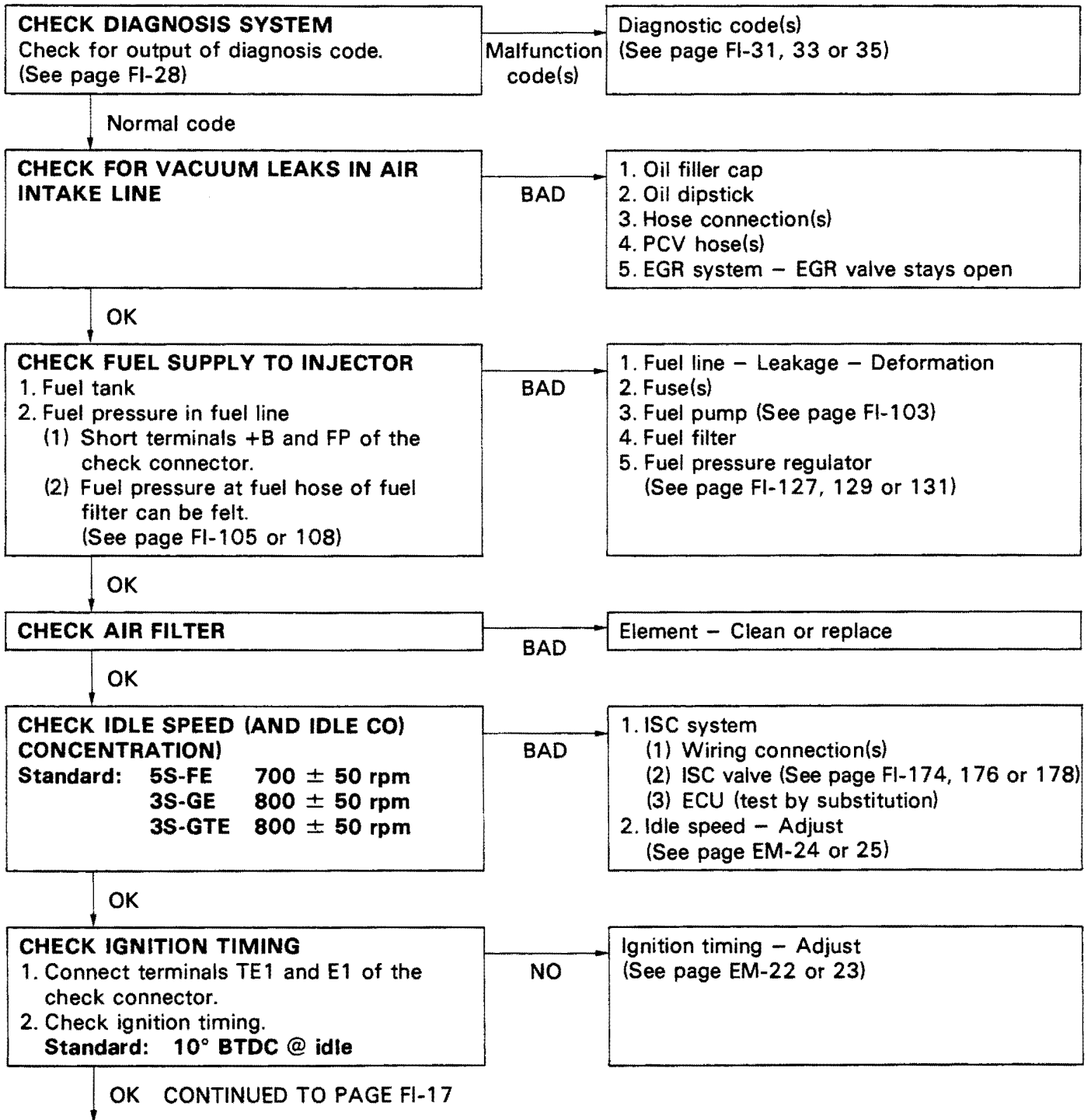

OK CONTINUED FROM PAGE FI-16

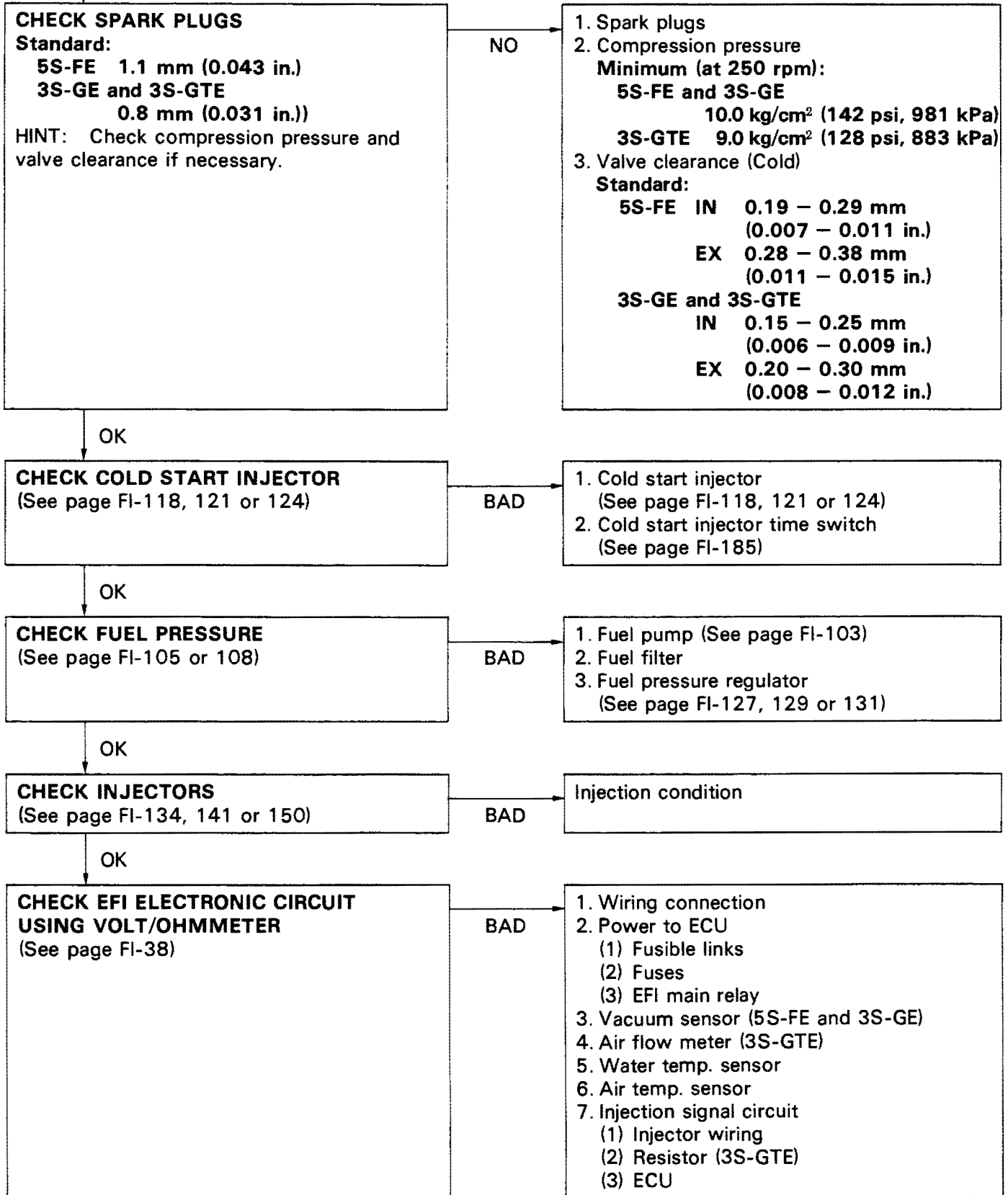

**SYMPTOM — ENGINE SOMETIMES STALLS**

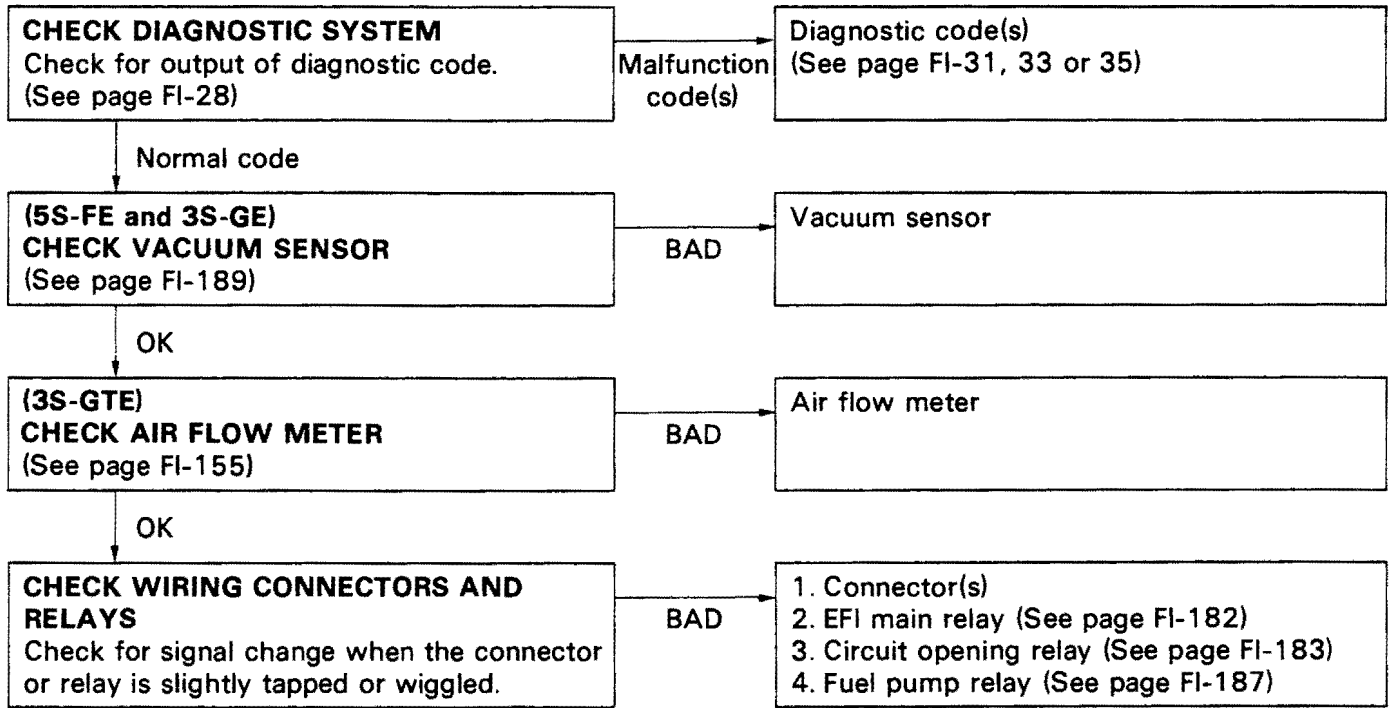

**SYMPTOM — ROUGH IDLING AND/MISSING**

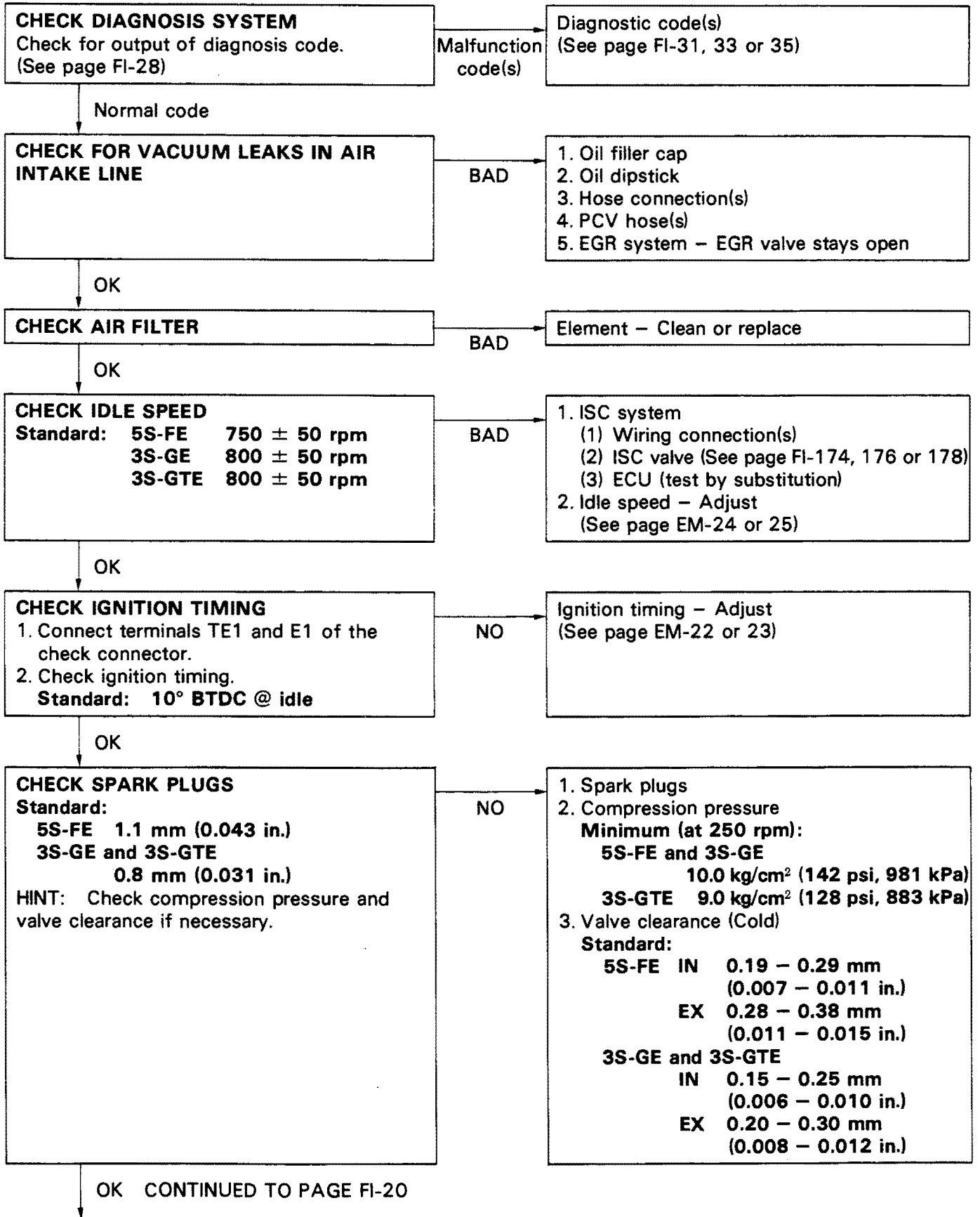

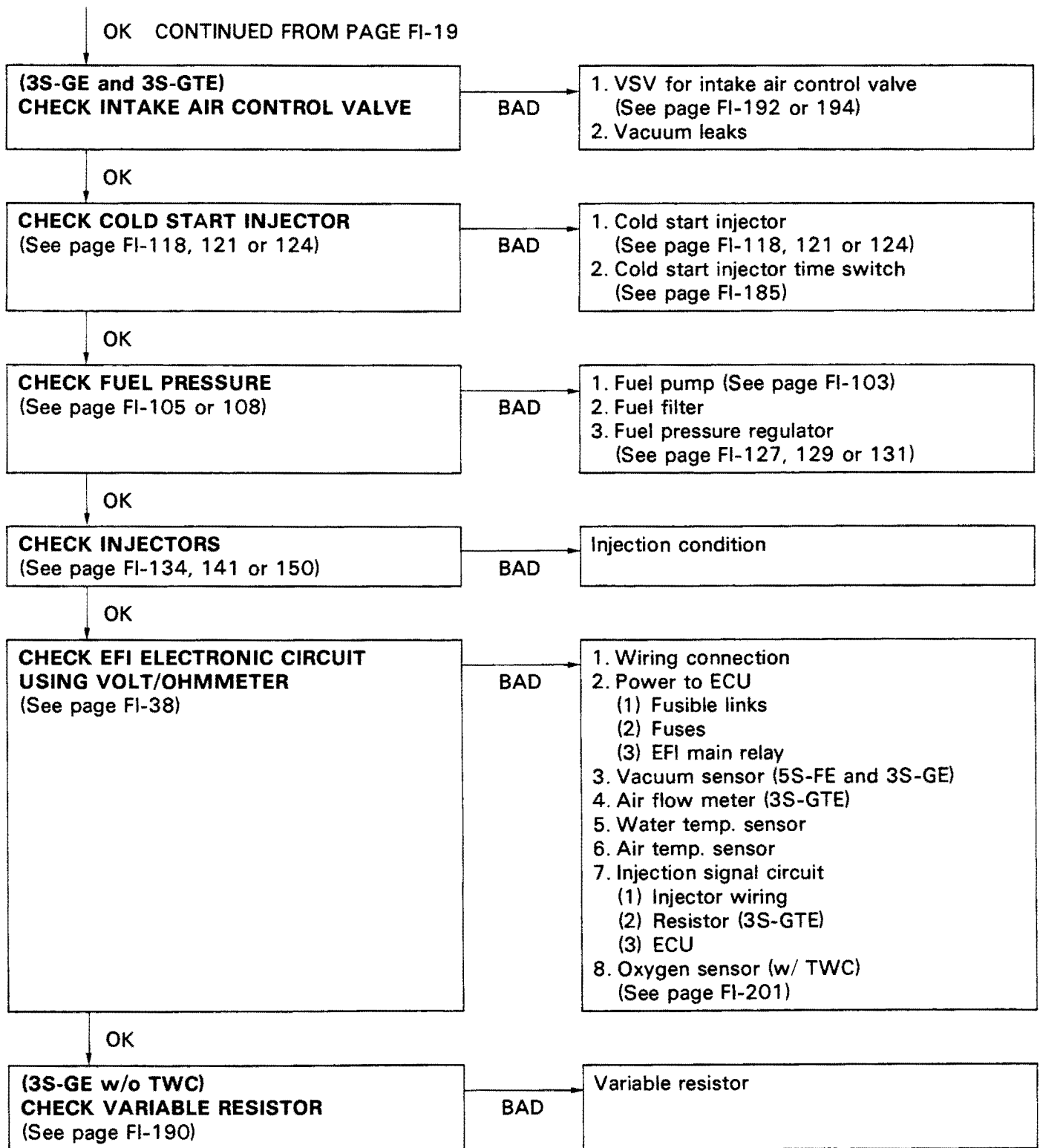

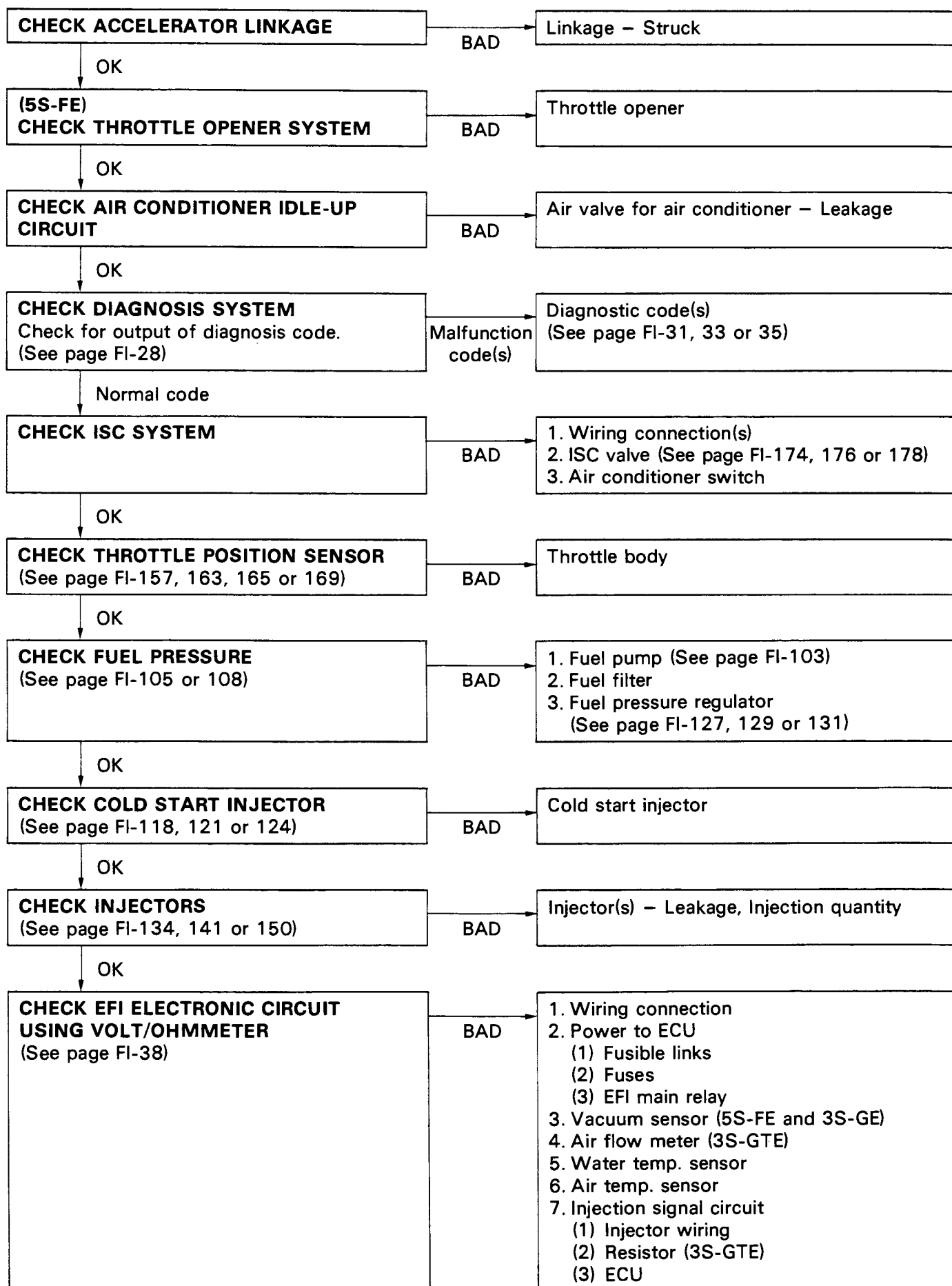
**SYMPTOM — HIGH ENGINE SPEED (NO DROP)**

**SYMPTOM — ENGINE BACKFIRES-Lean Fuel Mixture**

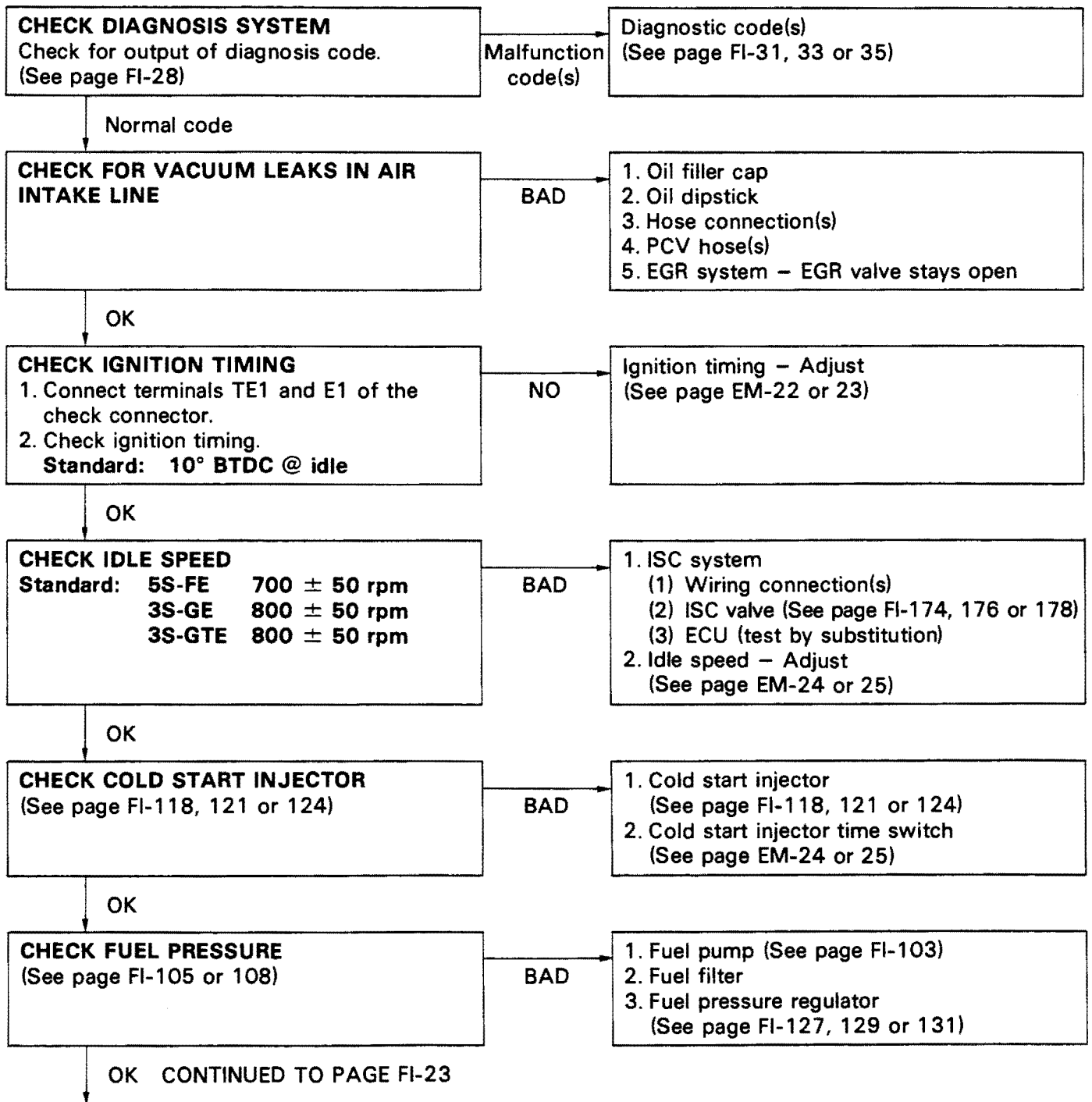



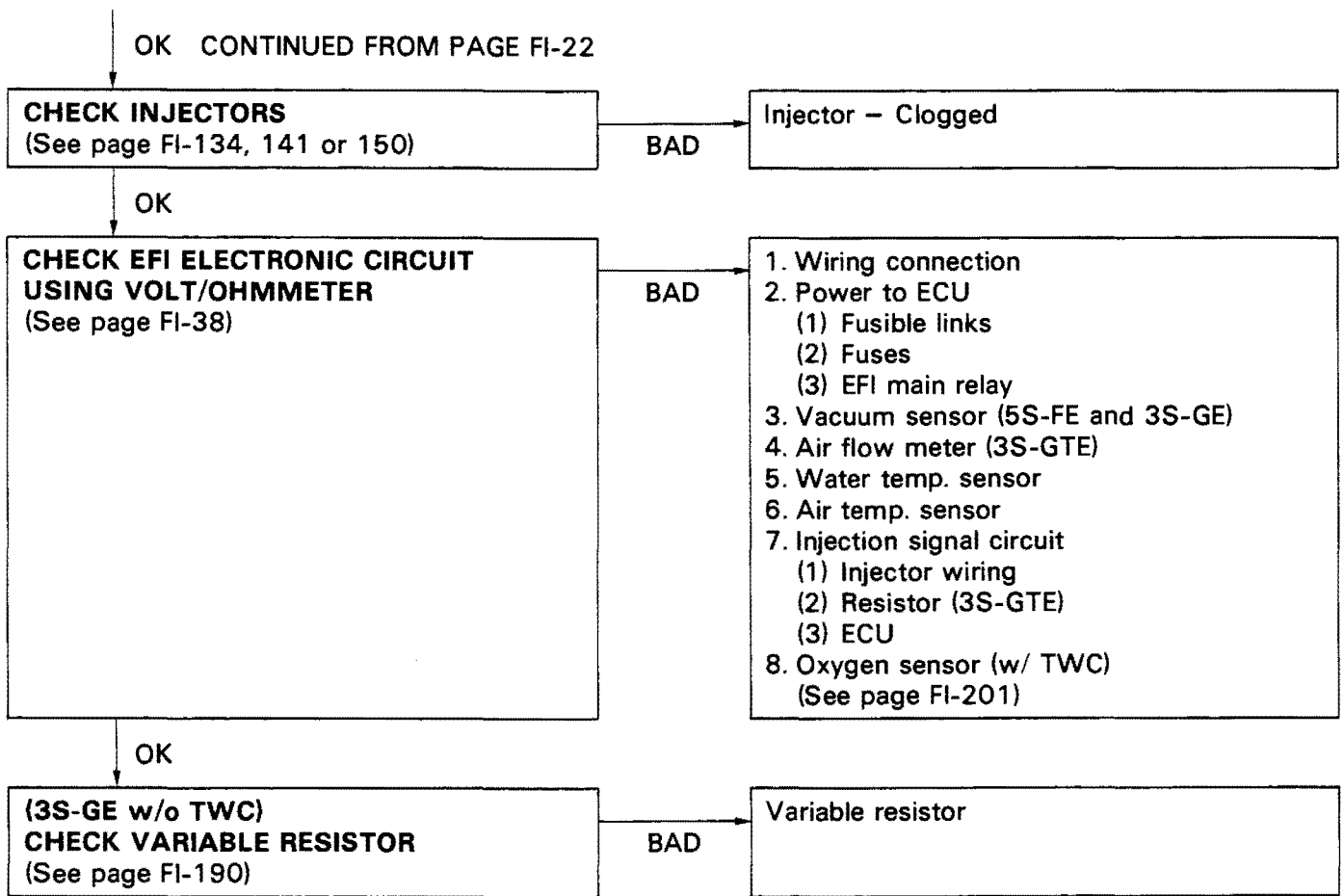

**SYMPTOM — MUFFLER EXPLOSION (AFTER FIRE)  
-Rich Fuel Mixture-Misfire**

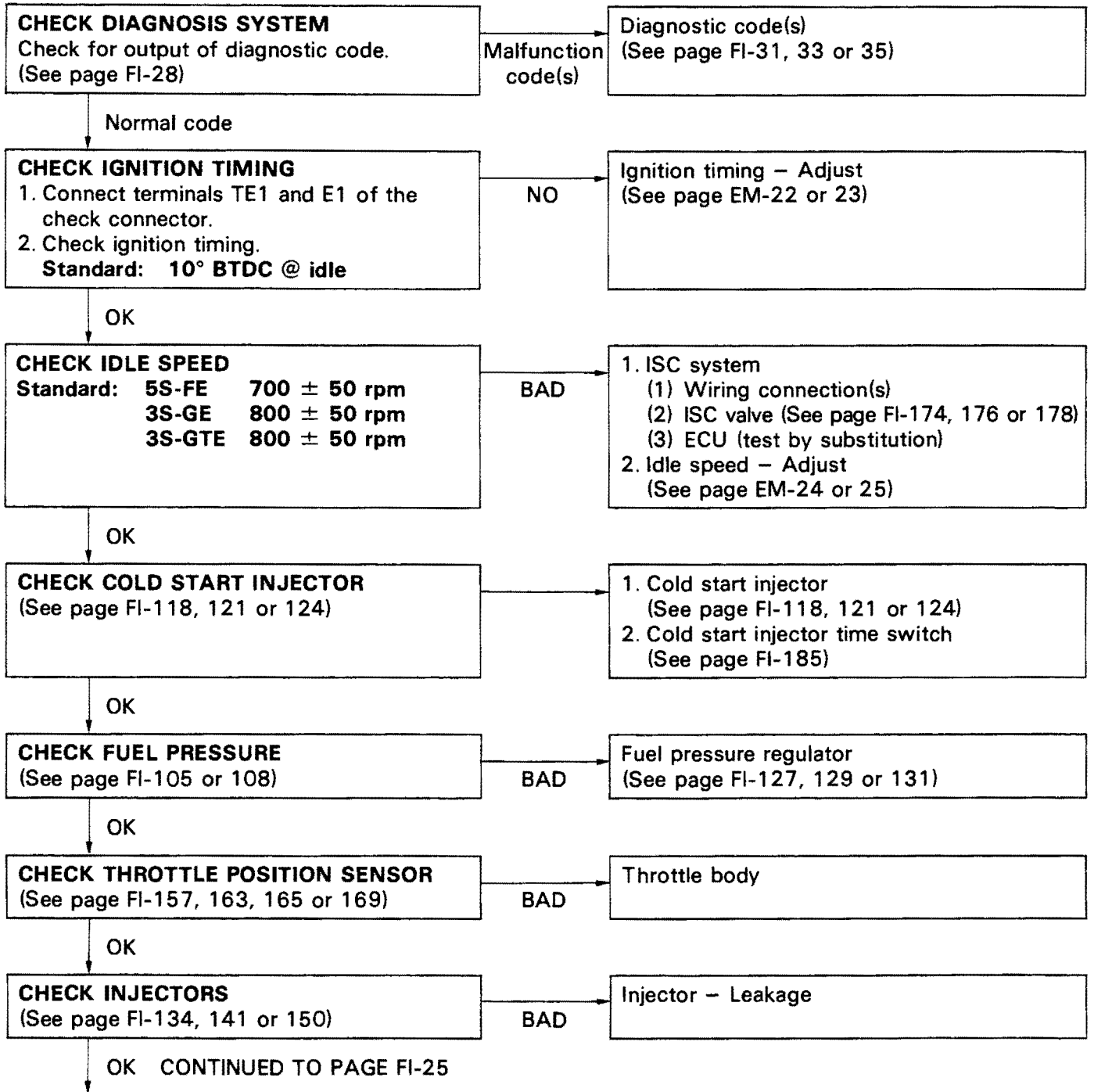

OK CONTINUED FROM PAGE FI-24

**CHECK SPARK PLUGS**  
**Standard:**  
 5S-FE 1.1 mm (0.043 in.)  
 3S-GE and 3S-GTE  
 0.8 mm (0.031 in.)  
**HINT:** Check compression pressure and valve clearance if necessary.

1. Spark plugs  
 2. Compression pressure  
**Minimum (at 250 rpm):**  
 5S-FE and 3S-GE  
 10.0 kg/cm<sup>2</sup> (142 psi, 981 kPa)  
 3S-GTE 9.0 kg/cm<sup>2</sup> (128 psi, 883 kPa)  
 3. Valve clearance (Cold)  
**Standard:**  
 5S-FE IN 0.19 – 0.29 mm  
 (0.007 – 0.011 in.)  
 EX 0.28 – 0.38 mm  
 (0.011 – 0.015 in.)  
 3S-GE and 3S-GTE  
 IN 0.15 – 0.25 mm  
 (0.006 – 0.010 in.)  
 EX 0.20 – 0.30 mm  
 (0.008 – 0.012 in.)

NO

OK

**CHECK EFI ELECTRONIC CIRCUIT  
 USING VOLT/OHMMETER**  
 (See page FI-38)

1. Throttle position sensor  
 2. Injection signal circuit  
 (1) Injector wiring  
 (2) Fuel cut PRM (See page FI-212)  
 (3) Engine ECU  
 3. Oxygen sensor (w/ TWC)

BAD

OK

**(3S-GE w/o TWC)**  
**CHECK VARIABLE RESISTOR**  
 (See page FI-190)

Variable resistor

BAD

**SYMPTOM — ENGINE HESITATES AND/OR POOR ACCELERATION**

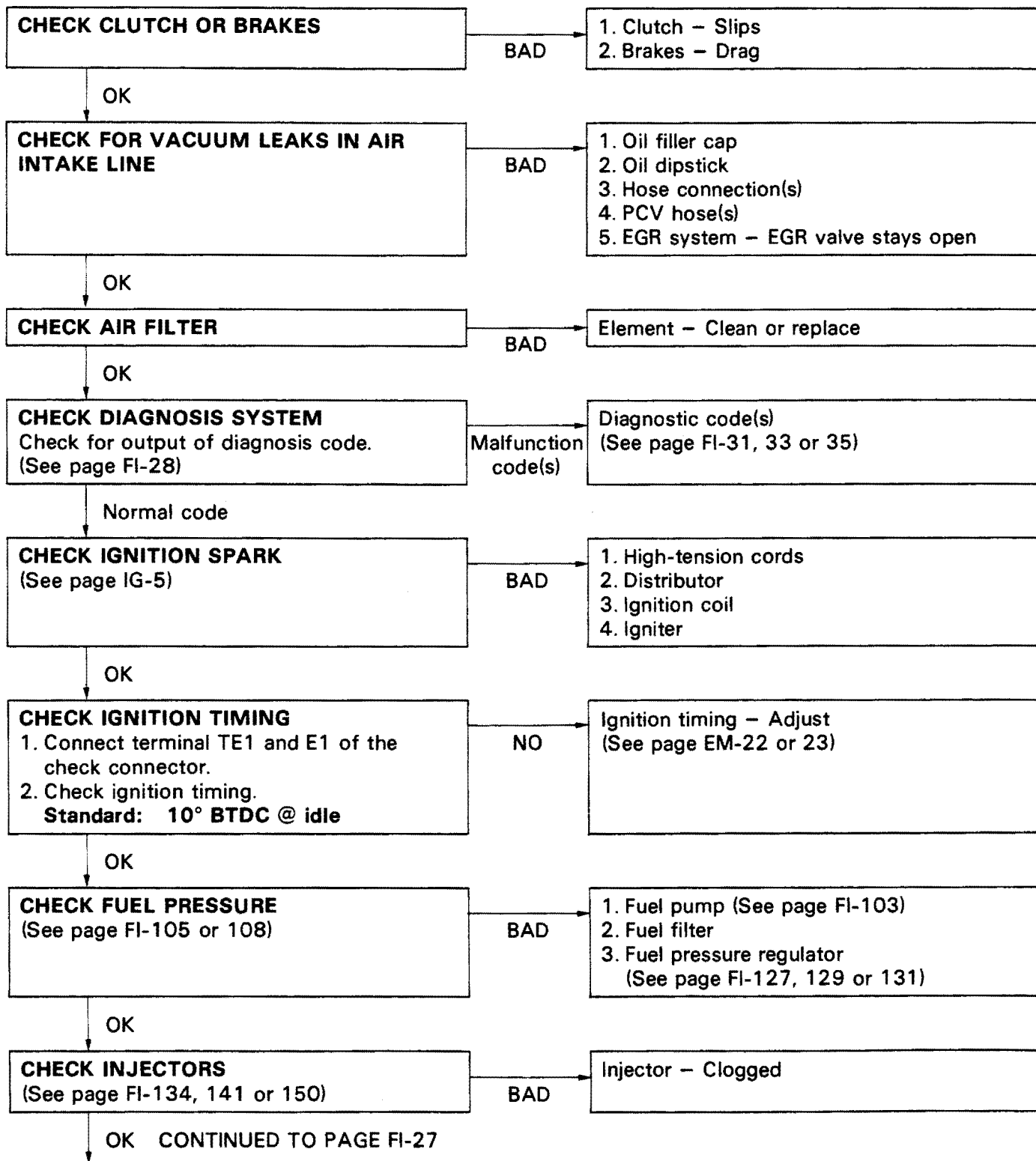

OK CONTINUED FROM PAGE FI-26

**(3S-GE and 3S-GTE)  
CHECK INTAKE AIR CONTROL VALVE  
(3S-GE)**

Check if air control valve is open with engine running at 5,100 rpm above.  
(3S-GTE (w/ Regular Gasoline))  
Check if air control valve is open with throttle valve open.  
(3S-GTE (w/ Premium Gasoline))  
Check if air control valve is open with engine running at 4,200 rpm above.

BAD

1. VSV for intake air control valve (See page FI-192 or 194)
2. Vacuum leaks

OK

**CHECK EFI ELECTRONIC CIRCUIT  
USING VOLT/OHMMETER  
(See page FI-38)**

BAD

1. Wiring connection
2. Power to ECU
  - (1) Fusible links
  - (2) Fuses
  - (3) EFI main relay
3. Vacuum sensor (5S-FE and 3S-GE)
4. Air flow meter (3S-GTE)
5. Water temp. sensor
6. Air temp. sensor
7. Injection signal circuit
  - (1) Injector wiring
  - (2) Resistor (3S-GTE)
  - (3) ECU

## DIAGNOSIS SYSTEM

### DESCRIPTION

The engine (and ECT) ECU contains a built-in, self-diagnosis system by which troubles with the engine signal network and then flashed a warning on the "CHECK" engine warning light on the instrument panel flashes.

By analyzing various signals shown in the tables (See page FI-31, 33 or 35) the engine (and ECT) ECU detects system malfunctions which are related to the various operating parameter sensors or actuator. The engine (and ECT) ECU stores the failure code associated with the detected failure until the diagnosis system is cleared by removing the EFI fuse with the ignition switch OFF.

A "CHECK" engine warning light on the instrument panel informs the driver that a malfunction has been detected.

The light goes off automatically when the malfunction has been cleared.

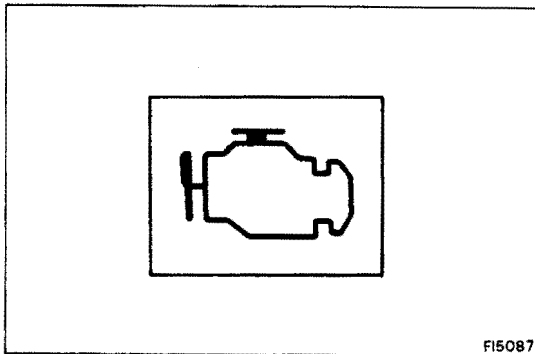

### "CHECK" ENGINE WARNING LIGHT CHECK

1. The "CHECK" engine warning light will come on when the ignition switch is placed at ON and the engine is not running.
2. When the engine is started, the "CHECK" engine warning light should go off.

If the light remains on, the diagnosis system has detected a malfunction or abnormality in the system.

### OUTPUT OF DIAGNOSTIC CODES

To obtain an output of diagnostic codes, proceed as follows:

1. Initial conditions
  - (a) Battery voltage 11 V or more
  - (b) Throttle valve fully closed (throttle position sensor IDL points closed)
  - (c) Transmission in neutral position
  - (d) Accessories switched OFF
  - (e) Engine at normal operating temperature
2. Turn the ignition switch ON. Do not start the engine.
3. Using SST, connect terminals TE1 and E1 of the check connector.  
SST 09843-18020

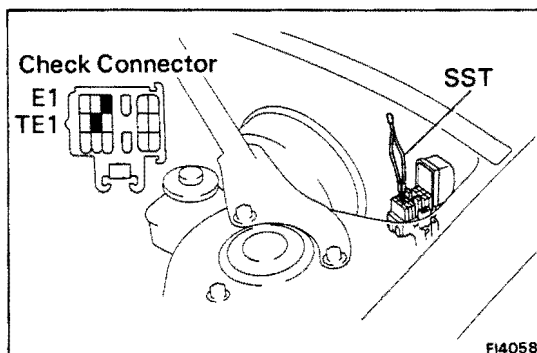

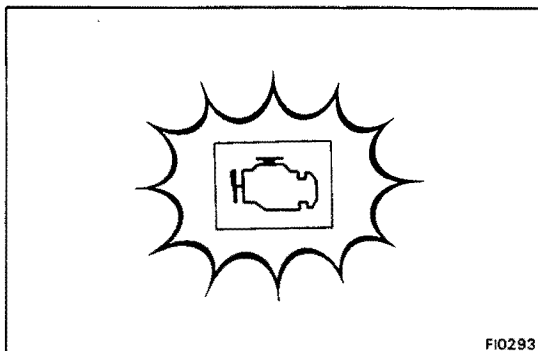

FI0293

4. Read the diagnostic code as indicated by the number of flashes of the "CHECK" engine warning light.

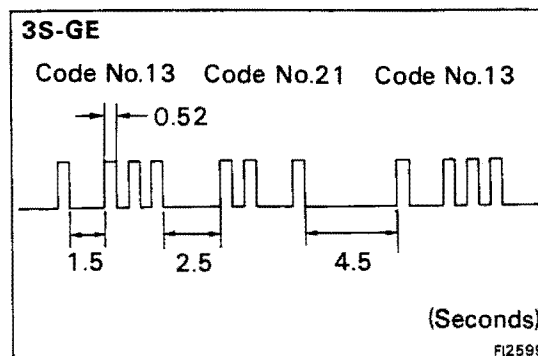
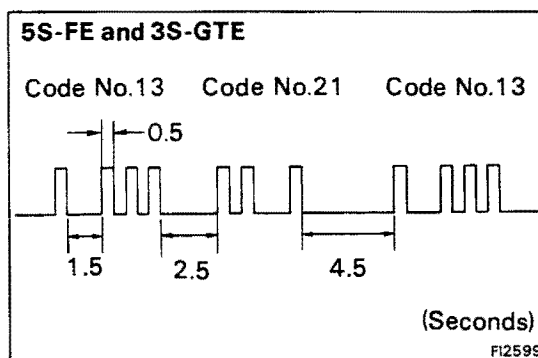
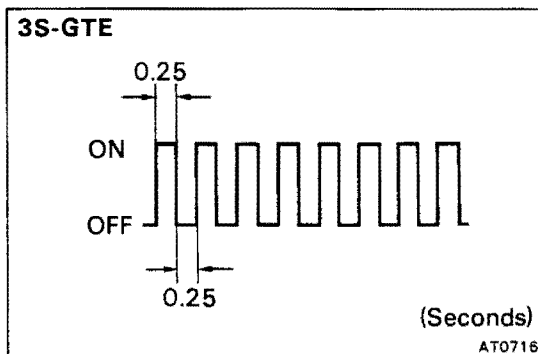
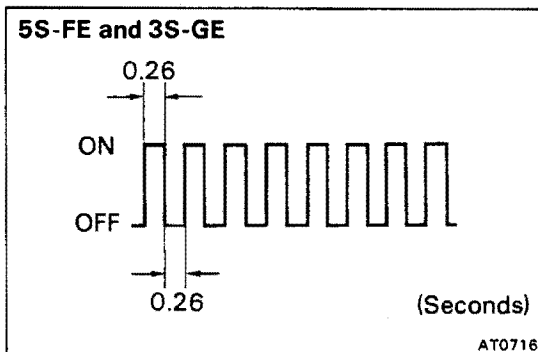

Diagnostic Codes (See page FI-31, 33 or 35)

- (a) Normal System Operation (no malfunction)

- The light will alternately blink ON and OFF about 2 times per second.

- (b) Malfunction Code Indication

- In the event of a malfunction, the light will blink every 0.5 seconds (5S-FE and 3S-GTE) or 0.52 seconds (3S-GE). The first number of blinks will equal the first digit of a 2-digit diagnostic code and, after a 1.5 second pause, the 2nd number of blinks will equal the 2nd. If there are two or more codes, there will be a 2.5 second pause between each.
- After all the codes have been signalled there will be a 4.5 second pause and they will all be repeated as long as the terminals TE1 and E1 of the check connector are connected.

**HINT:** In the event of a number of trouble codes, indication will begin from the smaller value and continue in order to the larger.

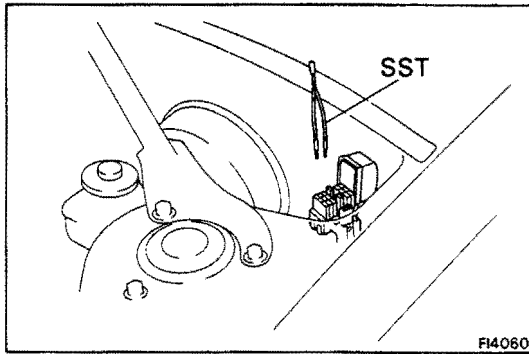

5. After the diagnostic check, remove SST.  
SST 09843-18020

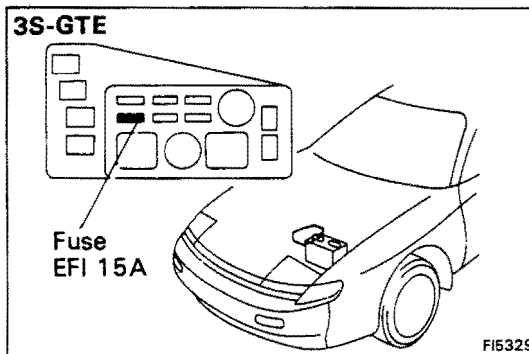
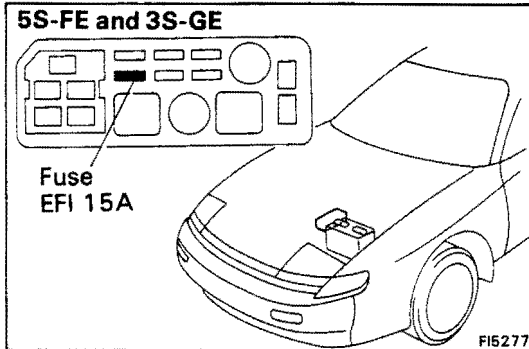

## CANCELLING DIAGNOSTIC CODE

1. After repairing of the trouble, the diagnostic code retained in memory by the engine (and ECT) ECU must be cancelled out by removing the EFI fuse (15 A) for 10 seconds or more, depending on ambient temperature (the lower the temperature, the longer the fuse must be left out) with the ignition switch OFF.

### HINT:

- Cancellation can also be done by removing the battery negative (-) terminal, but in this case, other memory systems (clock, etc.) will also be cancelled out.
- If the diagnostic code is not cancelled out, it will be retained by the engine (and ECT) ECU and appear along with a new code in the event of future trouble.
- If it is necessary to work on engine components requiring removal of the battery terminal, a check must first be made to see if a diagnostic code has been recorded.

2. After cancellation, road test the vehicle to check that a normal code is now displayed by the "CHECK" engine warning light.

If the same diagnostic code appears, it indicates that the trouble area has not been repaired thoroughly.

## DIAGNOSIS INDICATION

1. When 2 or more codes are indicated, the lowest number (code) will appear first.
2. All detected diagnostic codes, except code Nos.16, 51 and 53, will be retained in memory by the engine (and ECT) ECU from the time of detection until cancelled out.
3. Once the malfunction is cleared, the "CHECK" engine warning light on the instrument panel will go off but the diagnostic code(s) will remain stored in engine (and ECT) ECU memory (except for code Nos. 16, 51 and 53).



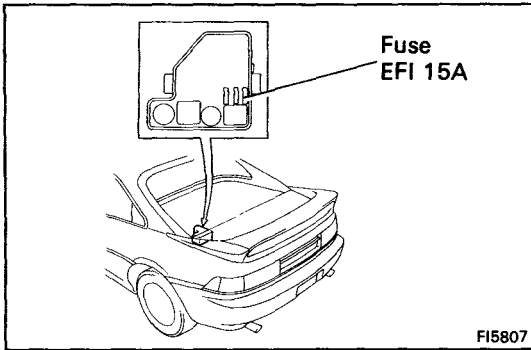

## CANCELLING DIAGNOSTIC CODE

1. After repair of the trouble area, the diagnostic code retained in memory by the ECU must be cancelled out by removing the fuse "EFI 15A" for 10 seconds or more, depending on ambient temperature (the lower the temperature, the longer the fuse must be left out) with the ignition switch OFF.

### HINT:









- Cancellation can also be done by removing the battery negative (-) terminal, but in this case, other memory systems (clock, etc.) will also be cancelled out.
  - If the diagnostic code is not cancelled out, it will be retained by the ECU and appear along with a new code in the event of future trouble.
  - If it is necessary to work on engine components requiring removal of the battery terminal, a check must first be made to see if a diagnostic code has been recorded.
2. After cancellation, perform road test of the vehicle to check that a normal code is now read on the "CHECK" engine warning light.

If the same diagnostic code appears, it indicates that the trouble area has not been repaired thoroughly.





## DIAGNOSIS INDICATION

1. When 2 or more codes are indicated, the lowest number (code) will appear first.
2. All detected diagnostic codes, except code No.51, and No.53 will be retained in memory by the ECU from the time of detection until cancelled out.
3. Once the malfunction is cleared, the "CHECK" engine warning light on the instrument panel will go off but the diagnostic code(s) remain stored in ECU memory (except for code No.51 and No.53).











**DIAGNOSTIC CODES (5S-FE)**

Code No.	Number of "CHECK" engine blinks	System	Diagnosis	Trouble area	See page
-	 FI1401	Normal	This appears when none of the other codes are identified.	-	-
12	 FI1606	PRM Signal	No "NE" or "G" signal to ECU within 2 seconds after engine has been cranked.	<ul style="list-style-type: none"> <li>● Distributor circuit</li> <li>● Distributor</li> <li>● Starter signal circuit</li> <li>● ECU</li> </ul>	IG-4
13	 FI1607	PRM Signal	No "NE" signal to ECU when engine speed is above 1,000 rpm.	<ul style="list-style-type: none"> <li>● Distributor circuit</li> <li>● Distributor</li> <li>● ECU</li> </ul>	-
14	 FI1608	Ignition Signal	No "IGF" signal to ECU 4-5 times in succession.	<ul style="list-style-type: none"> <li>● Igniter and ignition coil circuit</li> <li>● Igniter and ignition coil</li> <li>● ECU</li> </ul>	FI-49 or FI-65
21	 FI1609	Oxygen Sensor Signal	During air-fuel ratio feedback correction, voltage output from the oxygen sensor does not exceed a set value on the lean side and the rich side continuously for a certain period.	<ul style="list-style-type: none"> <li>● Oxygen sensor circuit</li> <li>● Oxygen sensor</li> <li>● ECU</li> </ul>	FI-53 or FI-69
22	 FI1610	Water Temp. Sensor Signal	Open or short circuit in water temp. sensor signal (THW).	<ul style="list-style-type: none"> <li>● Water temp. sensor circuit</li> <li>● Water temp. sensor</li> <li>● ECU</li> </ul>	FI-47 or FI-63
24	 FI1611	Intake Air Temp. Sensor Signal	Open or short circuit in intake air temp. sensor signal (THA).	<ul style="list-style-type: none"> <li>● Intake air temp. sensor circuit</li> <li>● Intake air temp. sensor</li> <li>● ECU</li> </ul>	FI-46 or FI-62
25	 FI2562	Air-Fuel Ratio Lean Malfunction	<ul style="list-style-type: none"> <li>● When air-fuel ratio feedback correction value or adaptive control value continues at the upper (lean) or lower (rich) limit for a certain period of time of adaptive control value is not renewed for a certain period of time.</li> </ul>	<ul style="list-style-type: none"> <li>● Injector circuit</li> <li>● Injector</li> <li>● Fuel line pressure</li> <li>● Vacuum Sensor</li> <li>● Air intake system</li> <li>● Oxygen sensor circuit</li> <li>● Oxygen sensor</li> <li>● Ignition system</li> <li>● Water temp. sensor</li> <li>● ECU</li> </ul>	-
26	 FI2563	Air-Fuel Ratio Rich Malfunction	<ul style="list-style-type: none"> <li>● When marked variation is detected in engine revolutions for each cylinder during idle switch on and feedback condition.</li> <li>● Open or short circuit in oxygen sensor signal (OX).</li> </ul>	<ul style="list-style-type: none"> <li>● Oxygen sensor circuit</li> <li>● Oxygen sensor</li> <li>● Injector circuit</li> <li>● Injector</li> <li>● Fuel line pressure</li> <li>● Cold start injector</li> <li>● Water temp. sensor</li> <li>● ECU</li> </ul>	-



## DIAGNOSTIC CODES (5S-FE) (Cont'd)

Code No.	Number of "CHECK" engine blinks	System	Diagnosis	Trouble area	See page
31	 FI1612	Vacuum Sensor Signal	Open or short circuit in vacuum sensor signal (PIM).	<ul style="list-style-type: none"> <li>● Vacuum sensor circuit</li> <li>● Vacuum sensor</li> <li>● ECU</li> </ul>	FI-44 or FI-60
41	 FI1614	Throttle Position Sensor Signal	<p>(w/o ECT) The "IDL" and "PSW" signals are output simultaneously for several seconds.</p> <p>(w/ ECT) Open or short circuit in throttle position sensor signal (VTA).</p>	<ul style="list-style-type: none"> <li>● Throttle position sensor circuit</li> <li>● Throttle position sensor</li> <li>● ECU</li> </ul>	FI-43 or FI-58
42	 FI1615	Vehicle Speed Sensor Signal	No "SPD" signal to ECU for 8 seconds when engine speed is between 2,300 rpm and 5,500 rpm and coolant temp. is above 80°C (176°F) except when racing the engine.	<ul style="list-style-type: none"> <li>● Vehicle speed sensor circuit</li> <li>● Vehicle speed sensor</li> <li>● ECU</li> </ul>	—
43	 FI1616	Starter Signal	No "STA" signal to ECU until engine speed reaches 800 rpm with vehicle not moving.	<ul style="list-style-type: none"> <li>● Ignition switch circuit</li> <li>● Ignition switch</li> <li>● ECU</li> </ul>	FI-48 or FI-64
51	 FI1617	Switch Condition Signal	No "IDL" signal, "NSW" signal or "A/C" signal to ECU, with the check connector terminals TE1 and E1 connected.	<ul style="list-style-type: none"> <li>● A/C switch circuit</li> <li>● A/C switch</li> <li>● A/C amplifier</li> <li>● Throttle position sensor circuit</li> <li>● Throttle position sensor</li> <li>● Neutral start switch circuit</li> <li>● Neutral start switch</li> <li>● Accelerator pedal and cable</li> <li>● ECU</li> </ul>	—

## DIAGNOSTIC CODES (3S-GE)

Code No.	Number of "CHECK" engine blinks	System	Diagnosis	Trouble area	See page
—	 FI1401	Normal	This appears when none of the other codes are identified.	—	—
12	 FI1606	PRM Signal	No "NE" or "G" signal to ECU within 2 seconds after engine has been cranked.	<ul style="list-style-type: none"> <li>● Distributor circuit</li> <li>● Distributor</li> <li>● Starter signal circuit</li> <li>● ECU</li> </ul>	IG-4
13	 FI1607	PRM Signal	No "NE" signal to ECU when engine speed is above 1,000 rpm.	<ul style="list-style-type: none"> <li>● Distributor circuit</li> <li>● Distributor</li> <li>● ECU</li> </ul>	—
14	 FI1608	Ignition Signal	No "IGF" signal to ECU 8-11 times in succession.	<ul style="list-style-type: none"> <li>● Igniter and ignition coil circuit</li> <li>● Igniter and ignition coil</li> <li>● ECU</li> </ul>	FI-81
*116	 FI3600	ECT Control Signal	ECT control program faulty.	<ul style="list-style-type: none"> <li>● ECU</li> </ul>	—
*21	 FI1609	Oxygen Sensor Signal	During air-fuel ratio feedback correction, voltage output from the oxygen sensor does not exceed a set value on the lean side and the rich side continuously for a certain period.	<ul style="list-style-type: none"> <li>● Oxygen sensor circuit</li> <li>● Oxygen sensor</li> <li>● ECU</li> </ul>	FI-85
		Oxygen Sensor Heater Circuit	Open or short circuit in oxygen sensor heater.	<ul style="list-style-type: none"> <li>● Oxygen sensor heater circuit</li> <li>● Oxygen sensor heater</li> </ul>	FI-85
22	 FI1610	Water Temp. Sensor Signal	Open or short circuit in water temp. sensor signal (THW).	<ul style="list-style-type: none"> <li>● Water temp. sensor circuit</li> <li>● Water temp. sensor</li> <li>● ECU</li> </ul>	FI-79
24	 FI1611	Intake Air Temp. Sensor Signal	Open or short circuit in intake air temp. sensor signal (THA).	<ul style="list-style-type: none"> <li>● Intake air temp. sensor circuit</li> <li>● Intake air temp. sensor</li> <li>● ECU</li> </ul>	FI-78
31	 FI1612	Vacuum Sensor Signal	Open or short circuit in vacuum sensor signal (PIM).	<ul style="list-style-type: none"> <li>● Vacuum sensor circuit</li> <li>● Vacuum sensor</li> <li>● ECU</li> </ul>	FI-76
41	 FI1614	Throttle Position Sensor Signal	Open or short circuit in throttle position sensor signal (VTA).	<ul style="list-style-type: none"> <li>● Throttle position sensor circuit</li> <li>● Throttle position sensor</li> <li>● ECU</li> </ul>	FI-74
42	 FI1615	Vehicle Speed Sensor Signal	No "SPD" signal to ECU for 8 seconds when engine speed is between 2,500 rpm and 5,000 rpm and coolant temp. is above 80°C (176°F) except when racing the engine.	<ul style="list-style-type: none"> <li>● Vehicle speed sensor circuit</li> <li>● Vehicle speed sensor</li> <li>● ECU</li> </ul>	—

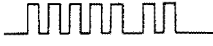

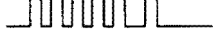





## DIAGNOSTIC CODES (3S-GE) (Cont'd)

Code No.	Number of "CHECK" engine blinks	System	Diagnosis	Trouble area	See page
43	 FI1616	Starter Signal	No "STA" signal to ECU until engine speed reaches 800 rpm with vehicle not moving.	<ul style="list-style-type: none"> <li>● Ignition switch circuit</li> <li>● Ignition switch</li> <li>● ECU</li> </ul>	FI-80
52	 FI1618	Knock Sensor Singal	Open or short circuit in knock sensor singal (KNK).	<ul style="list-style-type: none"> <li>● Knock sensor circuit</li> <li>● Knock sensor</li> <li>● ECU</li> </ul>	—
53	 FI1619	Knock Control Signal	Knock control program faulty.	<ul style="list-style-type: none"> <li>● ECU</li> </ul>	—
51	 FI1617	Switch Condition Signal	No "IDL" signal, "NSW" signal or "A/C" signal to ECU, with the check connector terminals TE1 and E1 connected.	<ul style="list-style-type: none"> <li>● A/C switch circuit</li> <li>● A/C switch</li> <li>● A/C amplifier</li> <li>● Throttle position sensor circuit</li> <li>● Throttle position sensor</li> <li>● Neutral start switch circuit</li> <li>● Neutral start switch</li> <li>● Accelerator pedal and cable</li> <li>● ECU</li> </ul>	—











\*1 w/ ECT

\*2 w/ TWC

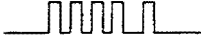
**DIAGNOSTIC CODES (3S-GTE)**

Code No.	Number of "CHECK" engine blinks	System	Diagnosis	Trouble area	See page
-	 FI1401	Normal	This appears when none of the other codes are identified.	-	-
12	 FI1606	PRM Signal	No "NE" or "G" signal to ECU within 2 seconds after engine has been cranked.	<ul style="list-style-type: none"> <li>● Distributor circuit</li> <li>● Distributor</li> <li>● Starter signal circuit</li> <li>● ECU</li> </ul>	IG-
13	 FI1607	PRM Signal	No "NE" signal to ECU when engine speed is above 1,000 rpm	<ul style="list-style-type: none"> <li>● Distributor circuit</li> <li>● Distributor</li> <li>● ECU</li> </ul>	-
14	 FI1608	Ignition Signal	No "IGF" signal to ECU 8-11 times in succession.	<ul style="list-style-type: none"> <li>● Igniter and ignition coil circuit</li> <li>● Igniter and ignition coil</li> <li>● ECU</li> </ul>	FI-97
21	 FI1609	Oxygen Sensor Signal	During air-fuel ratio feedback correction, voltage output from the oxygen sensor does not exceed a set value on the lean side and the rich side continuously for a certain period.	<ul style="list-style-type: none"> <li>● Oxygen sensor circuit</li> <li>● Oxygen sensor</li> <li>● ECU</li> </ul>	FI-102
		Oxygen Sensor Heater Circuit	Open or short circuit in oxygen sensor heater.	<ul style="list-style-type: none"> <li>● Oxygen sensor heater circuit</li> <li>● Oxygen sensor heater</li> </ul>	FI-102
22	 FI1610	Water Temp. Sensor Signal	Open or short circuit in water temp. sensor signal (THW).	<ul style="list-style-type: none"> <li>● Water temp. sensor circuit</li> <li>● Water temp. sensor</li> <li>● ECU</li> </ul>	FI-95
24	 FI1611	Intake Air Temp. Sensor Signal	Open or short circuit in intake air temp. sensor signal (THA).	<ul style="list-style-type: none"> <li>● Intake air temp. sensor circuit</li> <li>● Intake air temp. sensor</li> <li>● ECU</li> </ul>	FI-94
25	 FI2562	Air-Fuel Ratio Lean Malfunction	<ul style="list-style-type: none"> <li>● When air-fuel ratio feedback correction value or adaptive control value continues at the upper (lean) or lower (rich) limit renewed for a certain period of time.</li> <li>● Open or short circuit in oxygen sensor signal.</li> </ul>	<ul style="list-style-type: none"> <li>● Injector circuit</li> <li>● Injector</li> <li>● Fuel line pressure</li> <li>● Vacuum Sensor</li> <li>● Air intake system</li> <li>● Oxygen sensor circuit</li> <li>● Oxygen sensor</li> <li>● Ignition system</li> <li>● Water temp. sensor</li> <li>● ECU</li> </ul>	-
26	 FI2563	Air-Fuel Ratio Rich Malfunction	<ul style="list-style-type: none"> <li>● When air-fuel ratio feedback correction value or adaptive control value feedback frequency is abnormally high during feedback condition.</li> </ul>	<ul style="list-style-type: none"> <li>● Oxygen sensor circuit</li> <li>● Oxygen sensor</li> <li>● Injector circuit</li> <li>● Injector</li> <li>● Fuel line pressure</li> <li>● Cold start injector</li> <li>● Water temp. sensor</li> <li>● ECU</li> </ul>	-

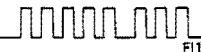
**DIAGNOSTIC CODES (3S-GTE) (Cont'd)**

Code No.	Number of "CHECK" engine blinks	System	Diagnosis	Trouble area	See page
31	 FI1612	Air-Flow Meter Signal	Open circuit in VC signal or short circuit between VS and E2 when idle contacts are closed.	<ul style="list-style-type: none"> <li>● Air flow meter circuit</li> <li>● Air flow meter</li> <li>● ECU</li> </ul>	FI-92
32	 FI1613	Air-Flow Meter Signal	Open circuit E2 or short circuit between VC and VS.	<ul style="list-style-type: none"> <li>● Air flow meter circuit</li> <li>● Air flow meter</li> <li>● ECU</li> </ul>	FI-92
34	 FI2818	Turbocharging Pressure Signal	Excessive turbocharging pressure.	<ul style="list-style-type: none"> <li>● Turbocharger</li> <li>● Turbocharging pressure sensor circuit</li> <li>● Turbocharging pressure sensor</li> <li>● ECU</li> </ul>	FI-100
35	 FI5125	Turbocharging Pressure Sensor Signal	Open or short circuit in turbocharging pressure sensor signal (PIM).	<ul style="list-style-type: none"> <li>● Turbocharging pressure sensor circuit</li> <li>● Turbocharging pressure sensor</li> <li>● ECU</li> </ul>	FI-100
41	 FI1614	Throttle Position Sensor Signal	Open or short circuit in throttle position sensor signal (VTA).	<ul style="list-style-type: none"> <li>● Throttle position sensor circuit</li> <li>● Throttle position sensor</li> <li>● ECU</li> </ul>	FI-90
42	 FI1615	Vehicle Speed Sensor Signal	No "SPD" signal for 8 seconds when engine speed is between 2,000 rpm and 5,000 rpm and coolant temp. is above 80°C (176°F) except when racing the engine.	<ul style="list-style-type: none"> <li>● Vehicle speed sensor circuit</li> <li>● Vehicle speed sensor</li> </ul>	—
43	 FI1616	Starter Signal	No "STA" signal to ECU until engine speed reaches 800 rpm with vehicle not moving.	<ul style="list-style-type: none"> <li>● Ignition switch circuit</li> <li>● Ignition switch</li> <li>● ECU</li> </ul>	FI-96
52	 FI1618	Knock Sensor Signal	Open or short circuit in knock sensor signal (KNK).	<ul style="list-style-type: none"> <li>● Knock sensor circuit</li> <li>● Knock sensor</li> <li>● ECU</li> </ul>	—
53	 FI1619	Knock Control signal	Knock control program faulty.	<ul style="list-style-type: none"> <li>● ECU</li> </ul>	—
51	 FI1617	Switch Condition Signal	No "IDL" signal or "A/C" signal to ECU, with check terminals TE1 and E1 connected.	<ul style="list-style-type: none"> <li>● A/C switch circuit</li> <li>● A/C switch</li> <li>● A/C amplifire</li> <li>● Throttle position sensor circuit</li> <li>● Throttle position sensor</li> <li>● ECU</li> </ul>	—

INSPECTION OF DIAGNOSIS CIRCUIT

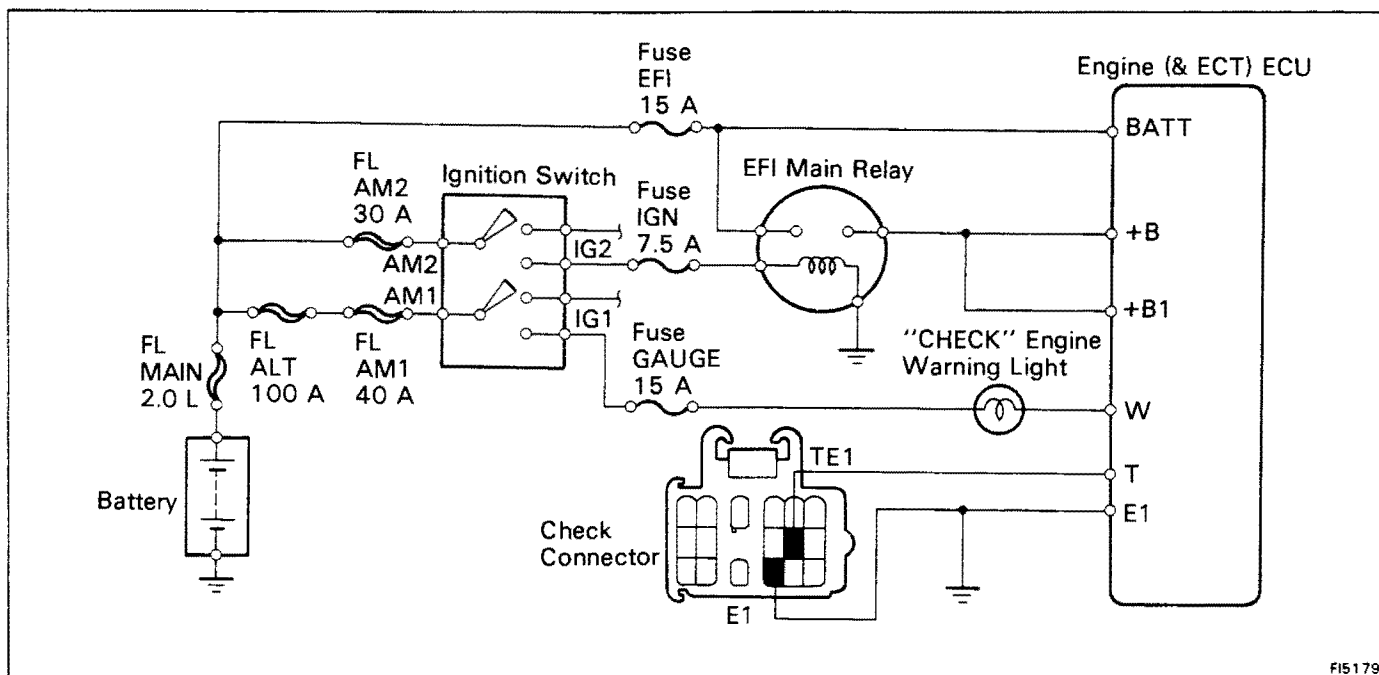

FI5179

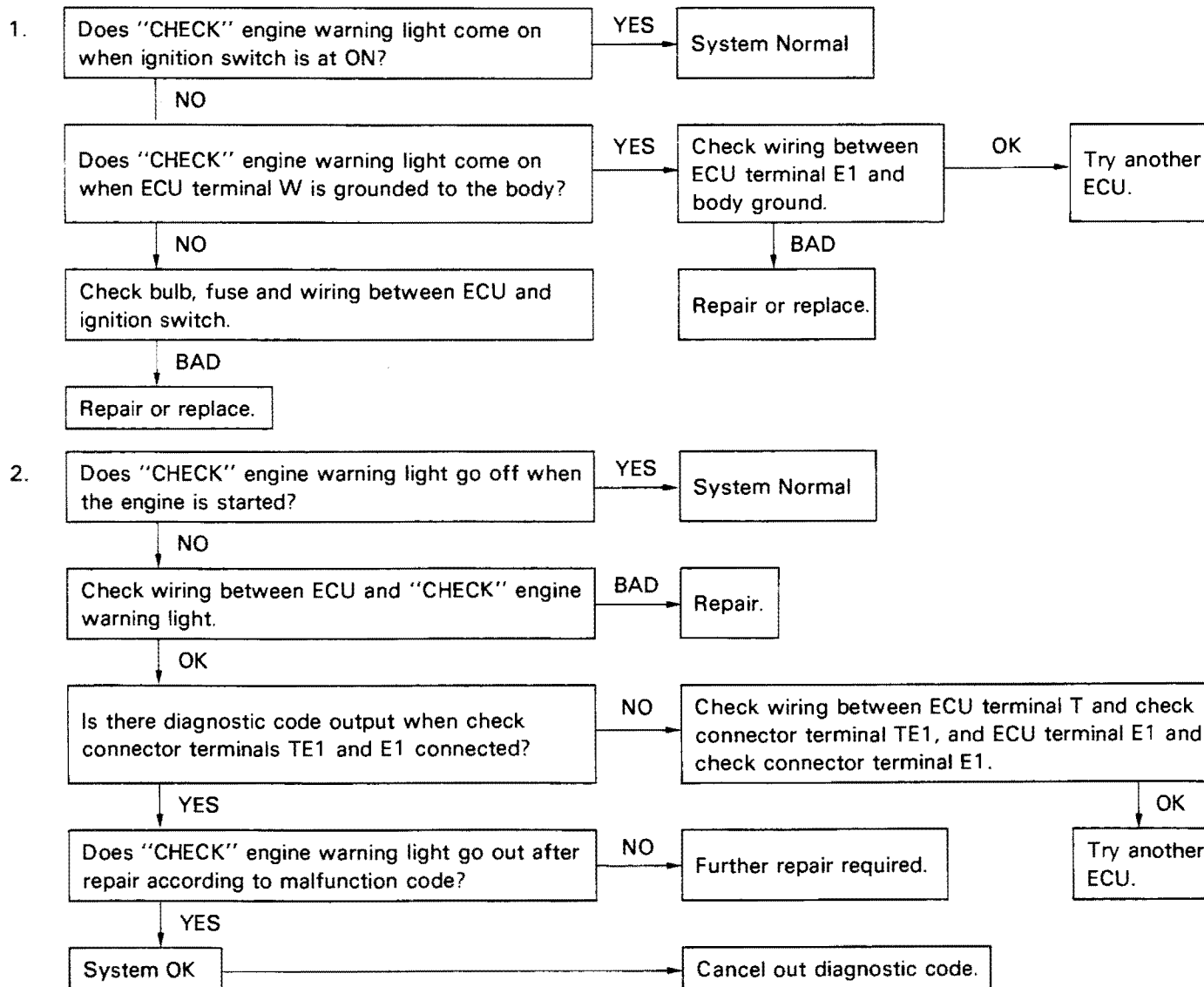



# TROUBLESHOOTING WITH VOLT/OHMMETER

**HINT:**

- The following troubleshooting procedures are designed for inspection of each separate system, therefore the procedures may vary somewhat. However, troubleshooting should be performed while referring to the inspection methods described in this manual.
- Before beginning inspection, it is best to first make a simple check of the fuses, fusible links and the condition of the connectors.
- The following troubleshooting procedures are based on the supposition that the trouble lies in either a short or open circuit in a component outside the computer or a short circuit within the computer.
- If engine trouble occurs even though proper operating voltage is detected in the computer connector, then it can be assumed that the engine (and ECT) ECU is faulty and should be replaced.

## LOCATION OF FUSES AND FUSIBLE LINKS

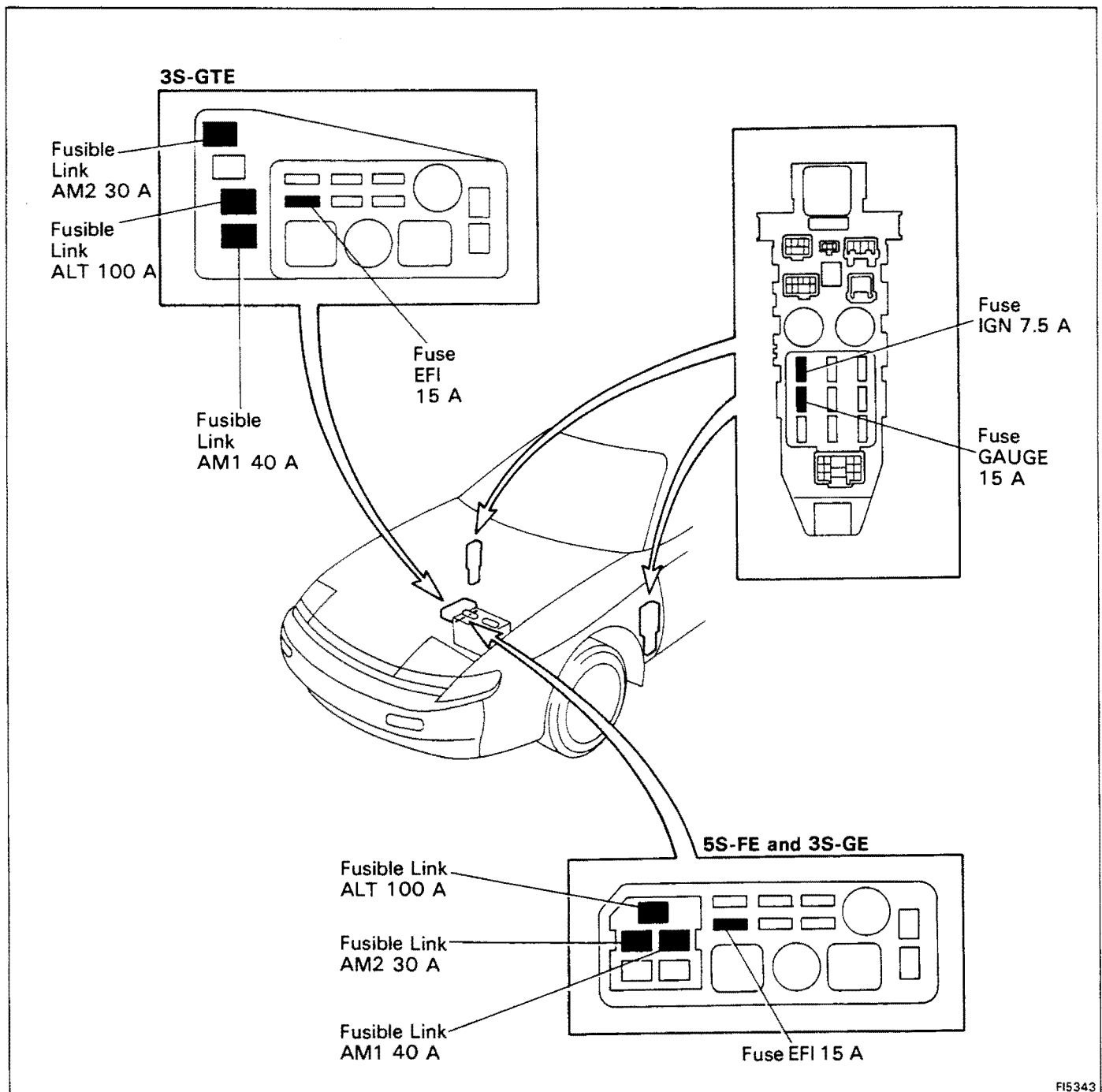

## TROUBLESHOOTING WITH VOLT/OHMMETER

### HINT:

- The following troubleshooting procedures are designed for inspection of each separate system, and therefore the actual procedure may vary somewhat. However, troubleshooting should be performed while referring to the inspection methods described in this manual.
- Before beginning inspection, it is best to first make a simple check of the fuses, fusible links and the condition of the connectors.
- The following troubleshooting procedures are based on the supposition that the trouble lies in either a short or open circuit in a components outside the computer or a short circuit within the computer.
- If engine trouble occurs even though proper operating voltage is detected in the computer connector, then it can be assumed that the ECU is faulty and should be replaced.

### LOCATION OF FUSES AND FUSIBLE LINKS

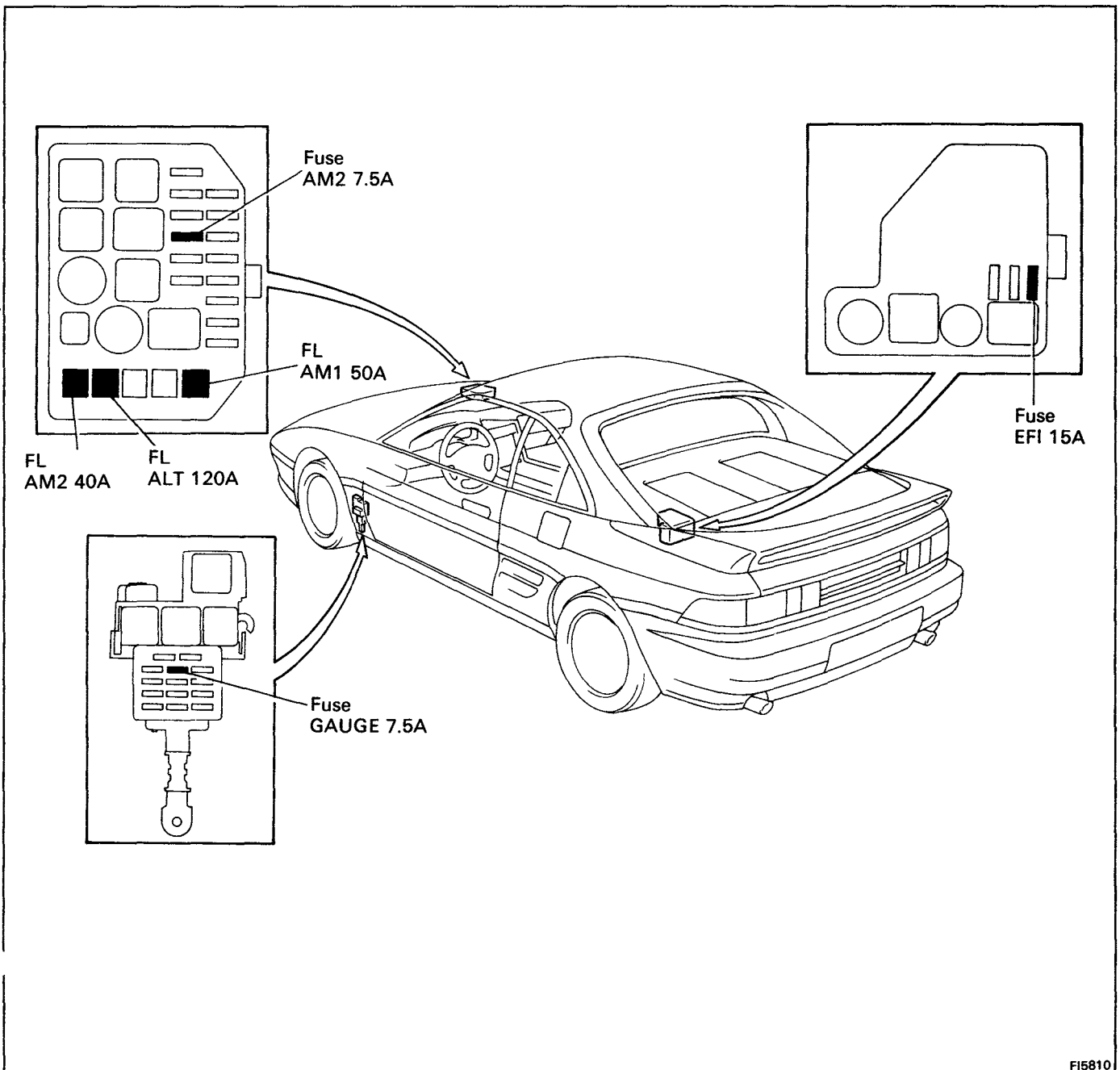

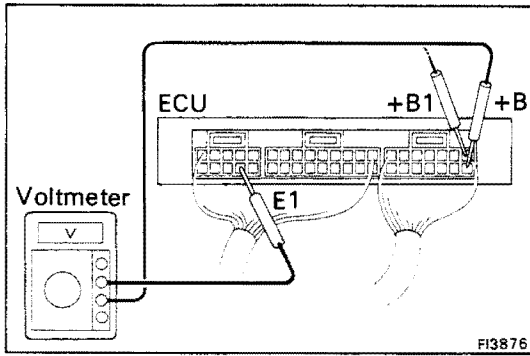

### EFI SYSTEM CHECK PROCEDURE (5S-FE w/o ECT)

**HINT:**

- Perform all voltage measurements with the connectors connected. (ex. Code No.10)
- Verify that the battery voltage is 11 V or more when the ignition switch is in "ON" position.

Using a voltmeter with high impedance (10 kΩ/V minimum), measure the voltage at each terminal of the wiring connectors.

### Terminals of Engine ECU

Symbol	Terminal name	Symbol	Terminal name	Symbol	Terminal name
E01	POWER GROUND	G ⊖	DISTRIBUTOR	ACA	A/C AMPLIFIER
E02	POWER GROUND	E21	SENSOR GROUND	OSFC	OVER SPEED FUEL CUT TERMINAL
No.10	INJECTOR	G1	DISTRIBUTOR	B/K	STOP LIGHT SWITCH
No.20	INJECTOR	NE	DISTRIBUTOR	ACT	A/C AMPLIFIER
STA	STARTER SWITCH	IGF	IGNITER	ELS	HEADLIGHT and DEFOGGER
IGT	IGNITER	/	-	SPD	SPEED SENSOR
/	-	T	CHECK CONNECTOR	FC	CIRCUIT OPENING RELAY
E1	ENGINE GROUND	IDL	THROTTLE POSITION	A/C	A/C MAGNET SWITCH
NSW	NEUTRAL START SWITCH	THA	AIR TEMP. SENSOR	VF	CHECK CONNECTOR
EGR	EGR VSV	VC	VACUUM SENSOR, THROTTLE POSITION SENSOR	/	-
ISCC	ISC VALVE	PIM	VACUUM SENSOR	BATT	BATTERY
ISCO	ISC VALVE	PSW	THROTTLE POSITION SENSOR	W	WARNING LIGHT
OX1	OXYGEN SENSOR	THW	WATER TEMP. SENSOR	+B1	MAIN RELAY
/	-	E2	SENSOR GROUND	+B	MAIN RELAY

**Engine ECU Terminals**

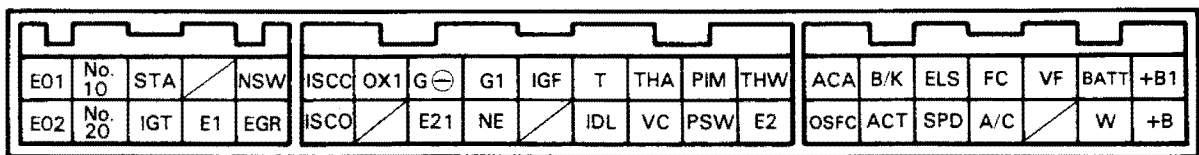

### Voltage at Engine ECU Wiring Connectors (5S-FE w/o ECT)

No.	Terminals	Condition	STD voltage (V)	See page
1	+B +B1 - E1	IG SW ON	10 - 14	FI-41
2	BATT - E1	-	10 - 14	FI-42
3	IDL - E1	IG SW ON	Throttle valve open	8 - 14
	PSW - E1		Throttle valve fully closed (Throttle opener must be cancelled first)	4 - 6
4	PIM - E2	IG SW ON	2.5 - 4.5	FI-44
	VC - E2		4 - 6	
5	No.10 E01 No.20 E02	IG SW ON	10 - 14	FI-45
6	THA - E2	IG SW ON	Intake air temp. 20°C (68°F)	FI-46
7	THW - E2		Coolant temp. 80°C (176°F)	FI-47
8	STA - E1	Cranking		FI-48
9	IGT - E1	Idling		FI-49
10	ISCC ISCO - E1	IG SW ON	Engine ECU connectors disconnected	FI-50
11	W - E1	No trouble ("CHECK" engine warning light off) and engine running		FI-51
12	A/C - E1	IG SW ON	Air conditioning ON	FI-52

**Engine ECU Terminals**

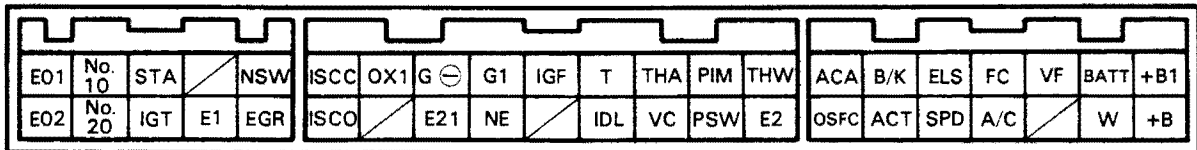

No.	Terminals	Trouble	Condition	STD Voltage
1	+B +B1 — E1	No voltage	IG SW ON	10 — 14 V

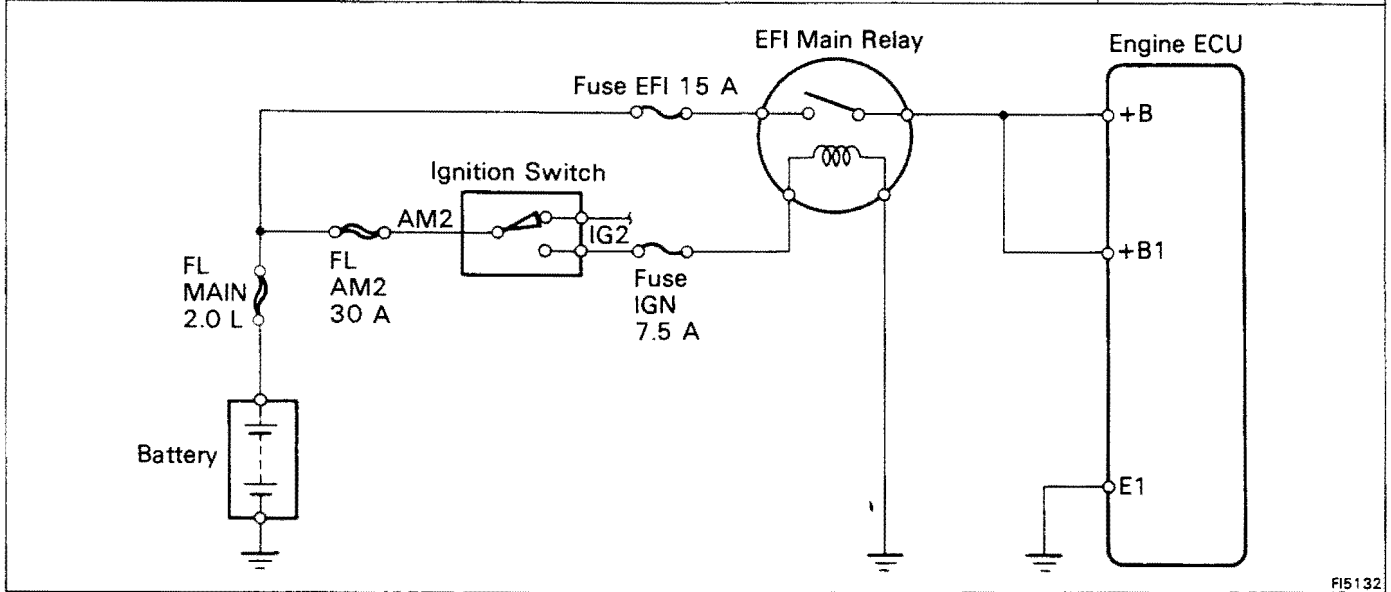

FI5132

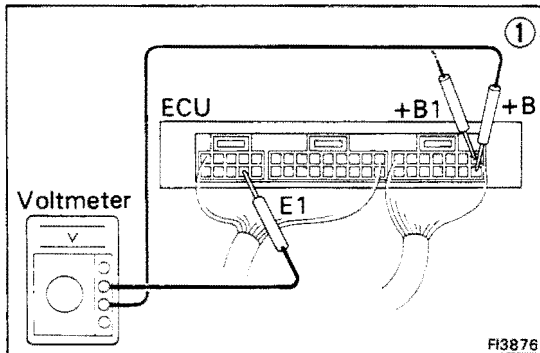

① There is no voltage between ECU terminals +B or +B1 and E1. (IG SW ON)

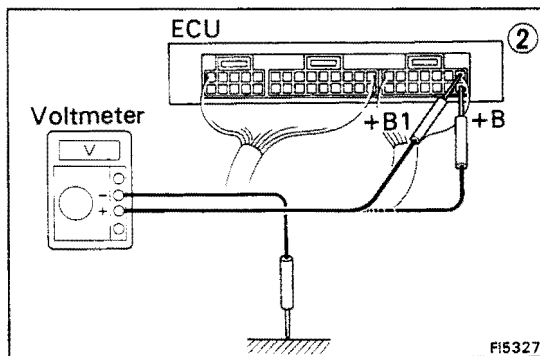

② Check that there is voltage between ECU terminal +B or +B1 and body ground. (IG SW ON)

NO OK

③ Check wiring between ECU terminal E1 and body ground.

NO OK

Try another ECU.

BAD  
Repair or replace.

Check fuses, fusible links and ignition switch.

BAD  
Repair or replace.

OK  
Check EFI main relay. (see page FI-182)

BAD  
Replace.

OK  
Check wiring between EFI main relay and battery.

BAD  
Repair or replace.

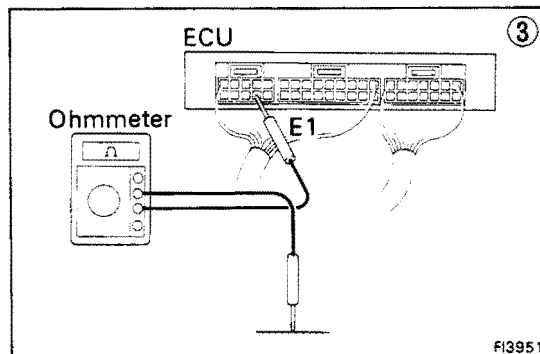

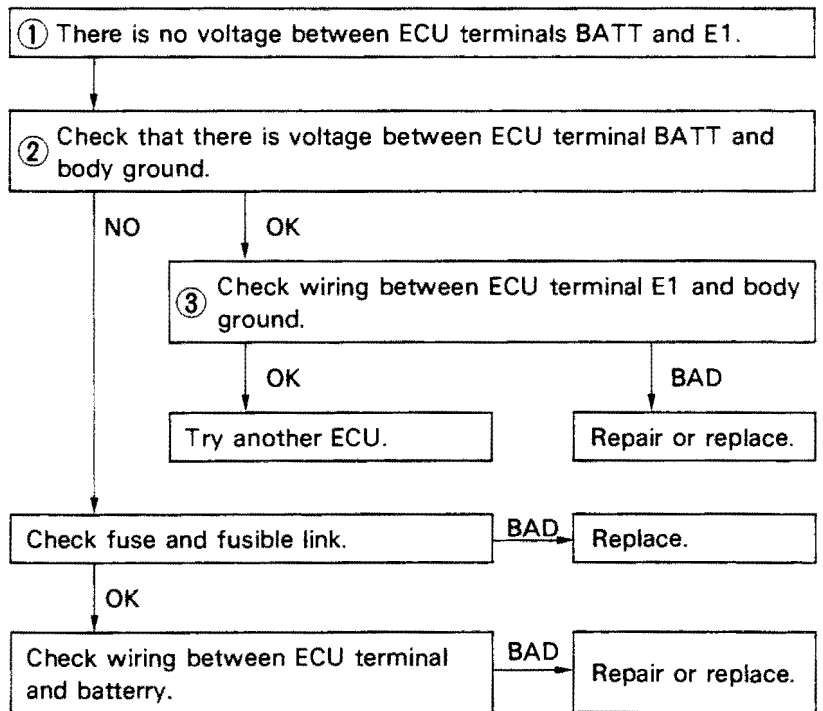
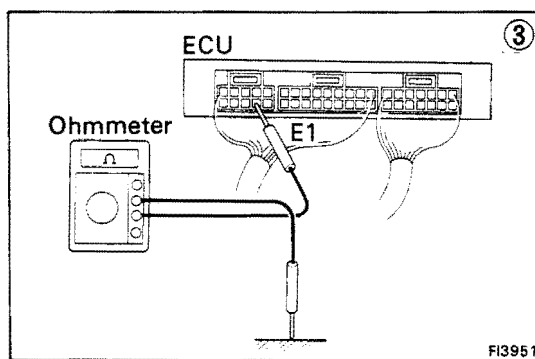
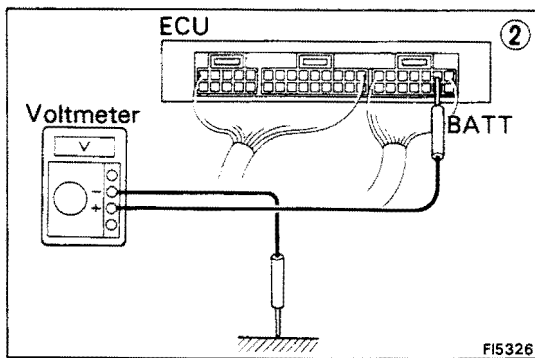
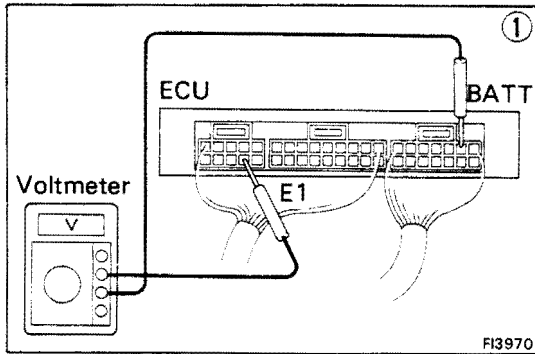
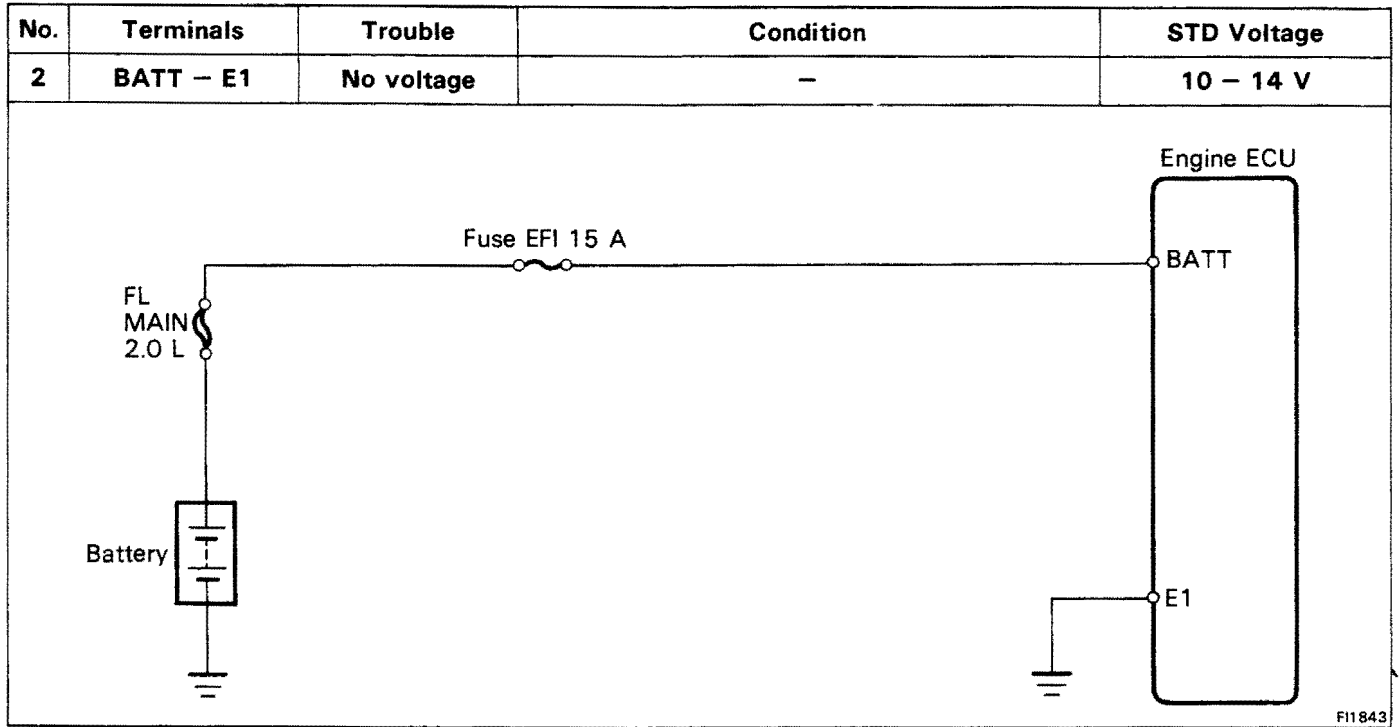

No.	Terminals	Trouble	Condition	STD Voltage	
3	IDL - E1	No voltage	IG SW ON	Throttle valve open	8 - 14 V
	PSW - E1			Throttle valve fully closed (Throttle opener must be cancelled first)	4 - 6 V

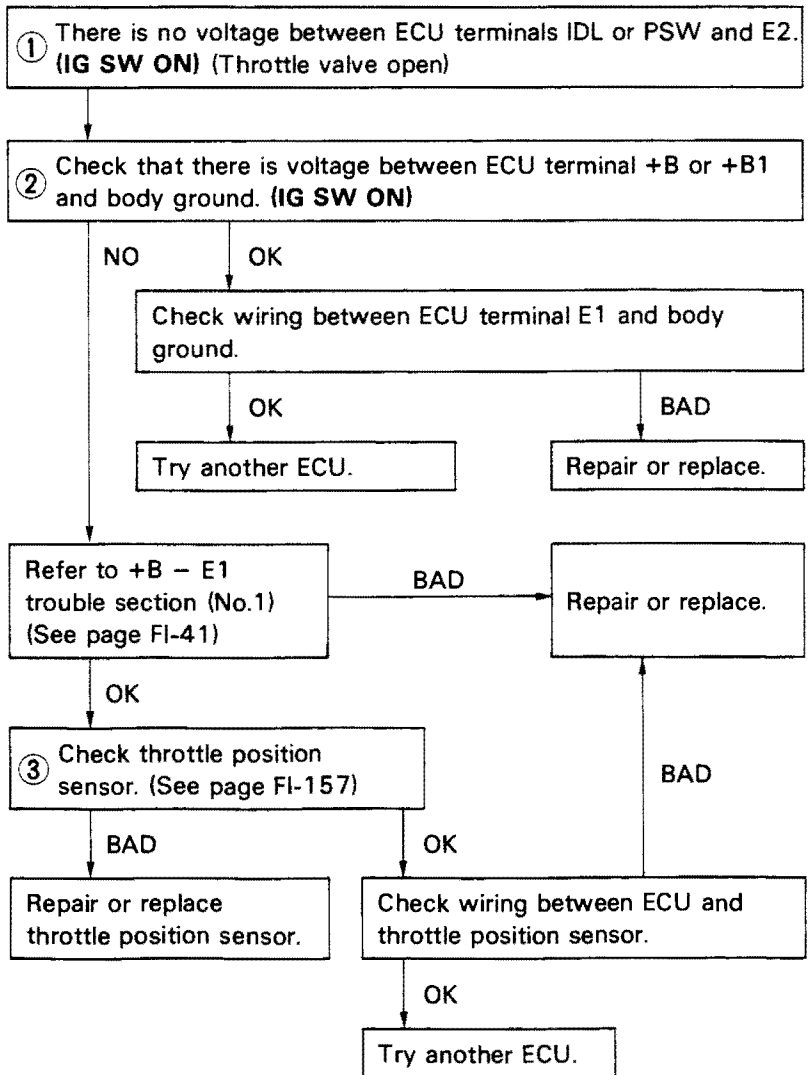
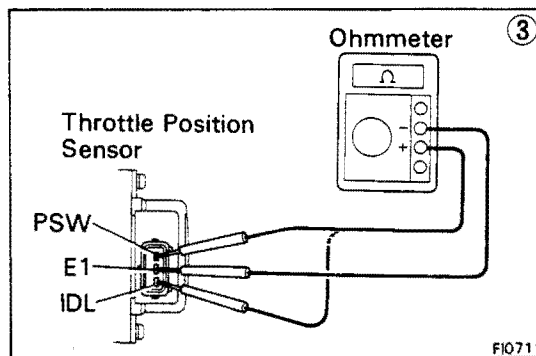
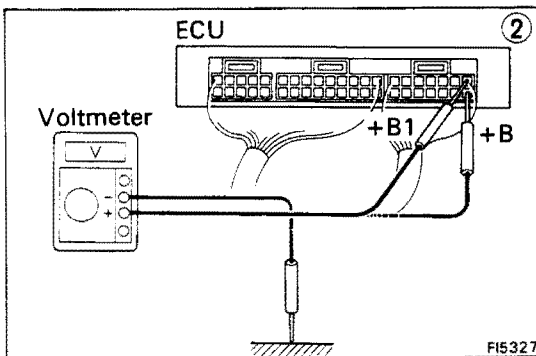
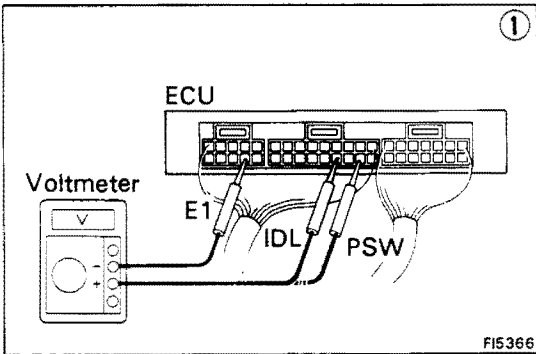
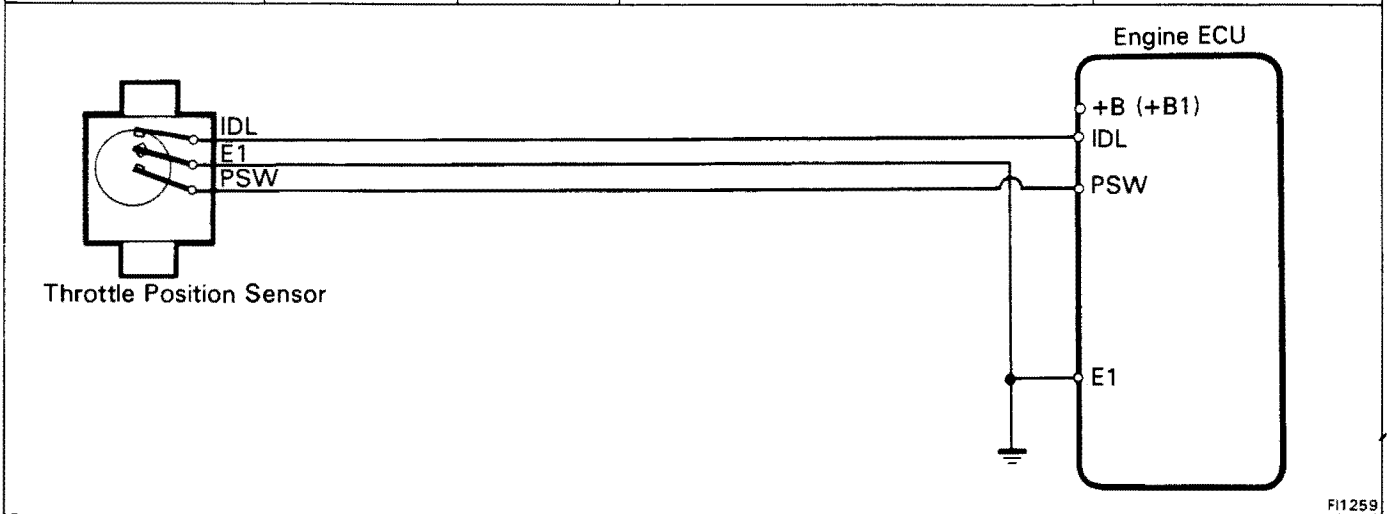

No.	Terminals	Trouble	Condition	STD Voltage
4	PIM — E2	No voltage	IG SW ON	2.5 — 4.5 V
	VC — E2			4 — 6 V

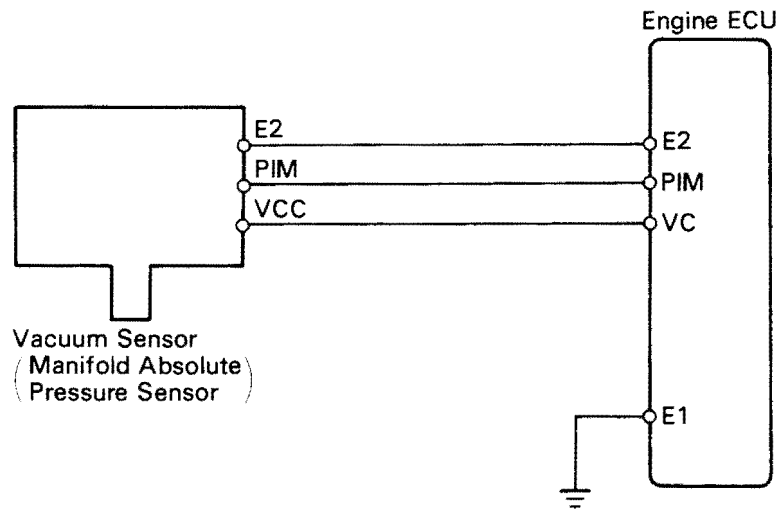

FI1226

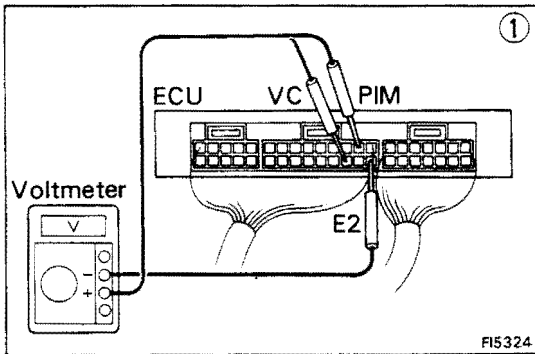

① There is no voltage between ECU terminals PIM or VC and E2. (IG SW ON)

② Check that there is voltage between ECU terminal +B or +B1 and body ground. (IG SW ON)

OK

NO

Refer to +B — E1 trouble section (No.1). (See page FI-41)

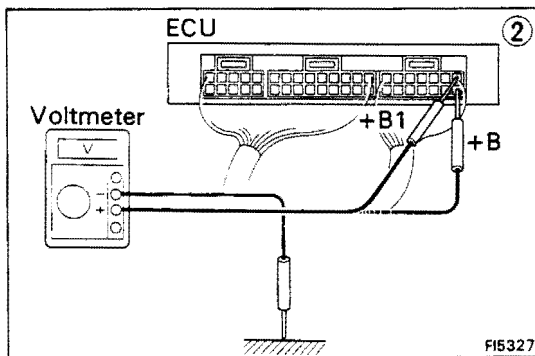

③ Check wiring between ECU terminal E1 and body ground.

OK

BAD

Check vacuum sensor. (See page FI-189)

Repair or replace.

BAD

OK

Replace vacuum sensor.

Check wiring between ECU and vacuum sensor.

OK

BAD

Try another ECU.

Repair or replace.

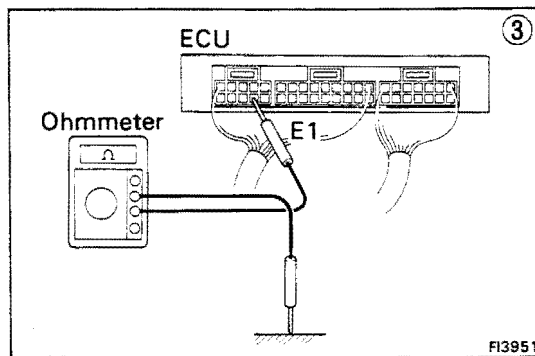



No.	Terminals	Trouble	Condition	STD Voltage
5	No.10 — E01 No.20 — E02	No voltage	Ignition switch ON	10 — 14 V

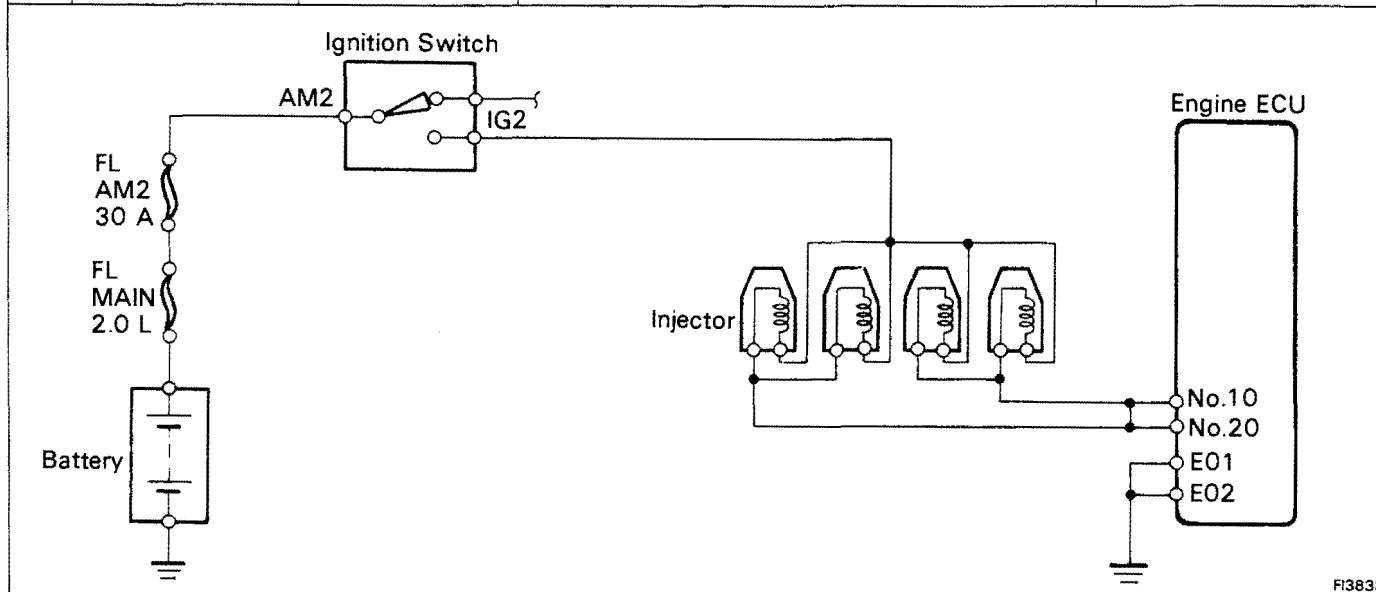

FI3838

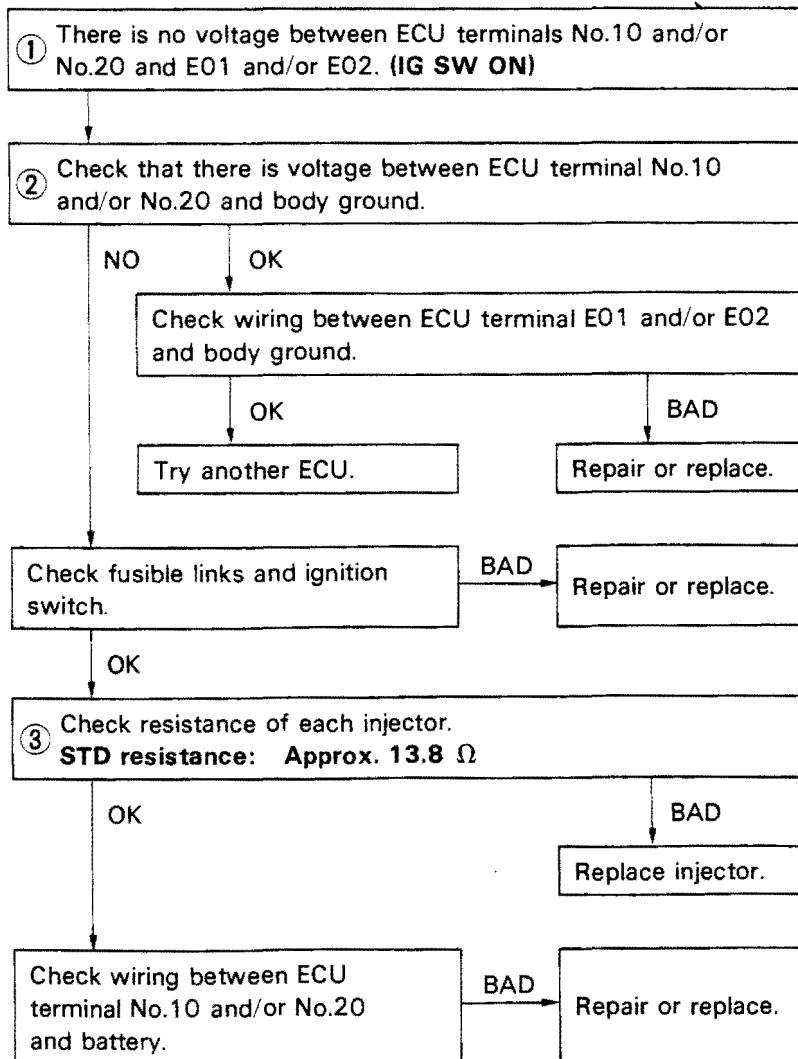
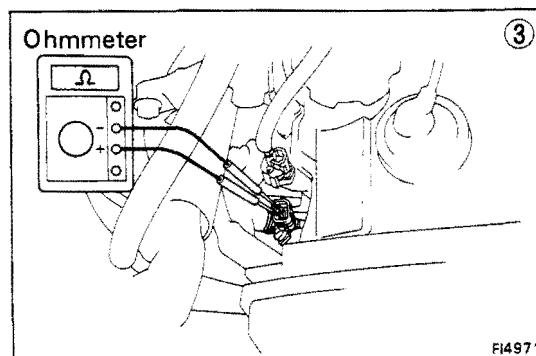
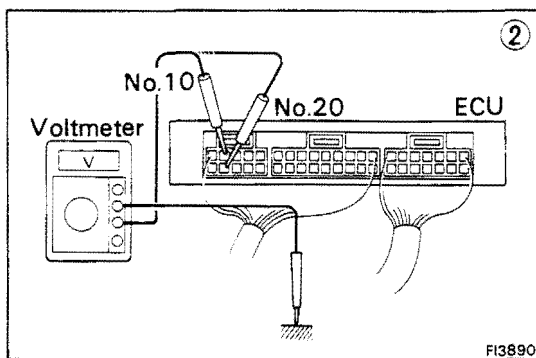
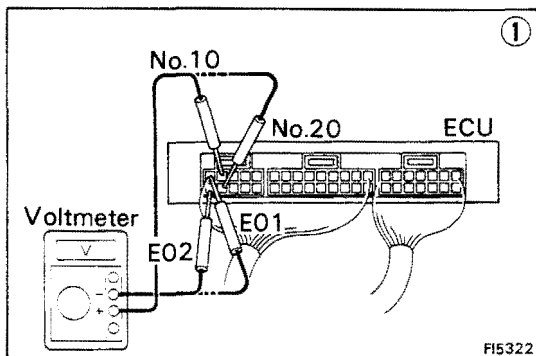

No.	Terminals	Trouble	Condition		STD Voltage
6	THA - E2	No voltage	IS SW ON	Intake air temperature 20°C (68°F)	2.0 - 2.8 V

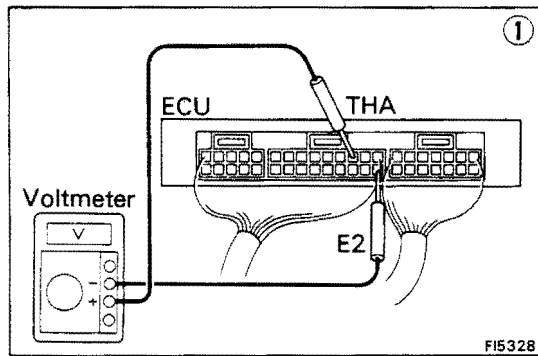
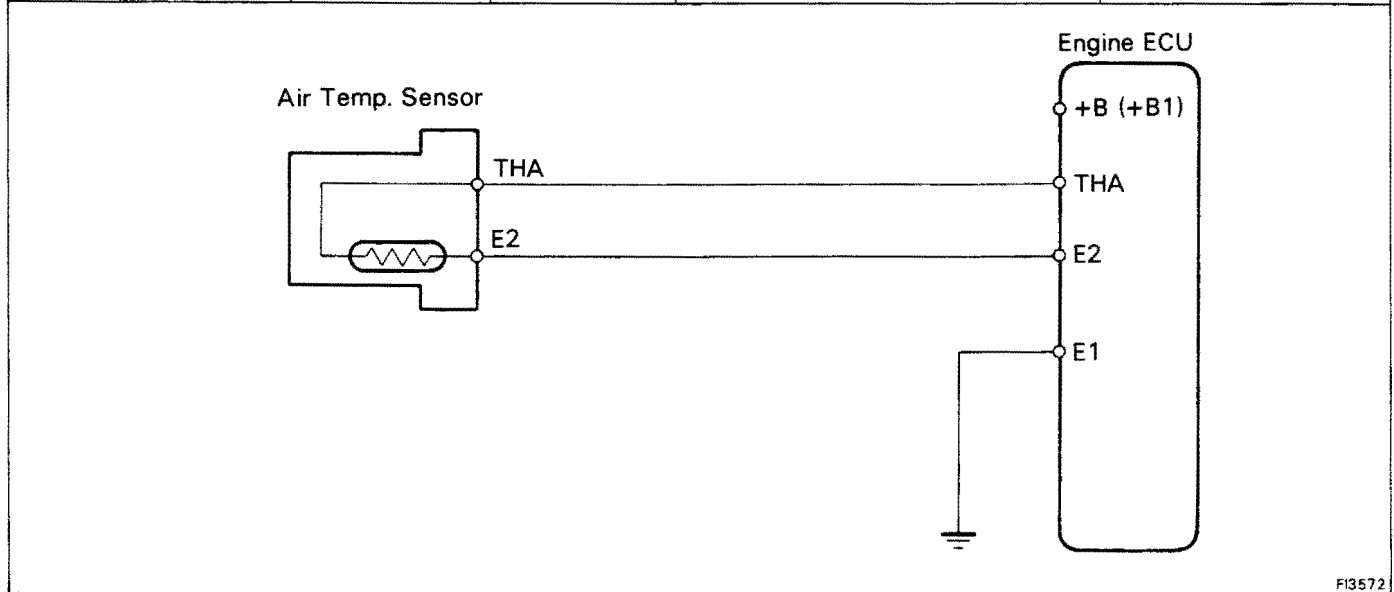

① There is no voltage between ECU terminals THA and E2. (IG SW ON)

② Check that there is voltage between ECU terminal +B or +B1 and body ground. (IG SW ON)

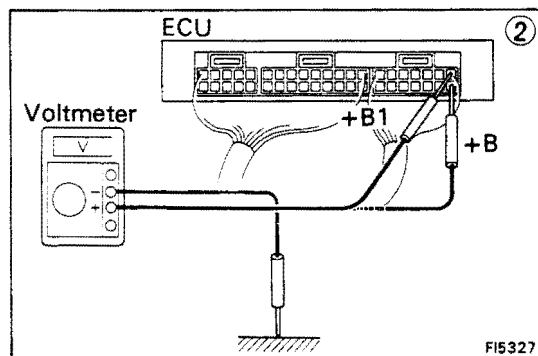

OK

NO

Refer to +B - E1 trouble section No.1. (See page FI-41)

Check wiring between ECU terminal E1 and body ground.

OK

BAD

③ Check air temp. sensor. (See page FI-188)

Repair or replace.

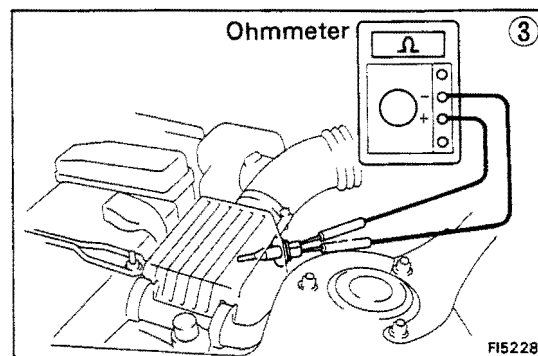

BAD

OK

Replace air temp. sensor.

Check wiring between ECU and air temp. sensor.

OK

BAD

Try another ECU.

Repair or replace.

No.	Terminals	Trouble	Condition		STD Voltage
7	THW – E2	No voltage	IG SW ON	Coolant temperature 80°C (176°F)	0.1 – 1.0 V

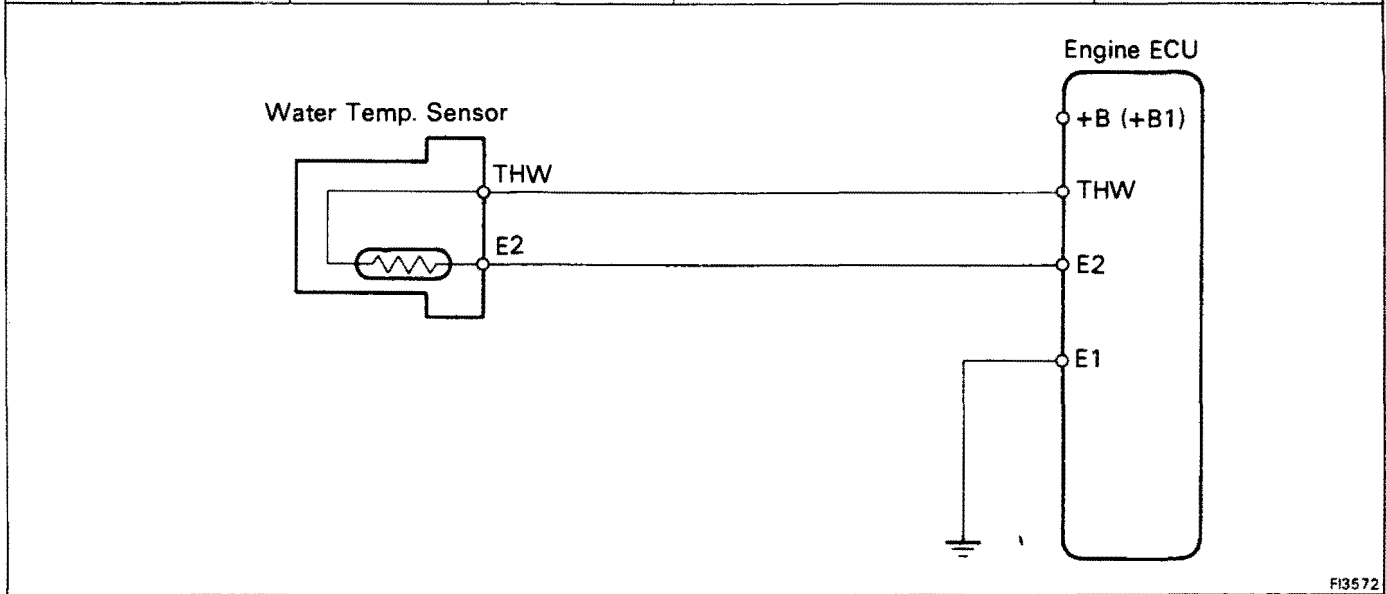

FI3572

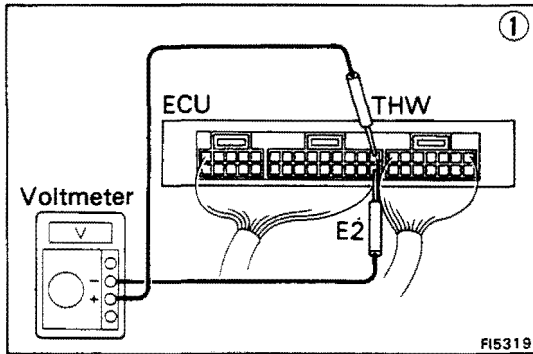

FI5319

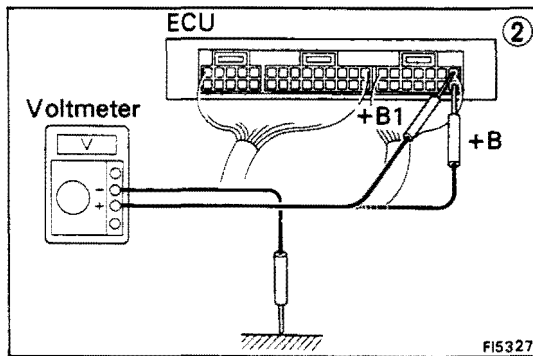

FI5327

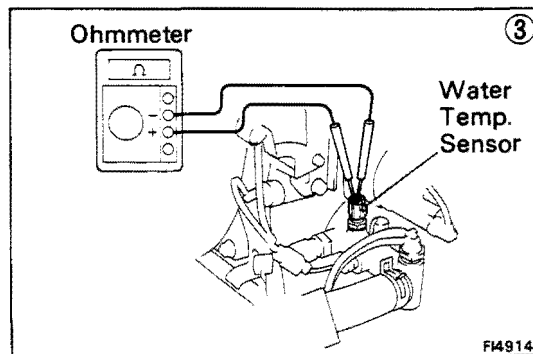

FI4914

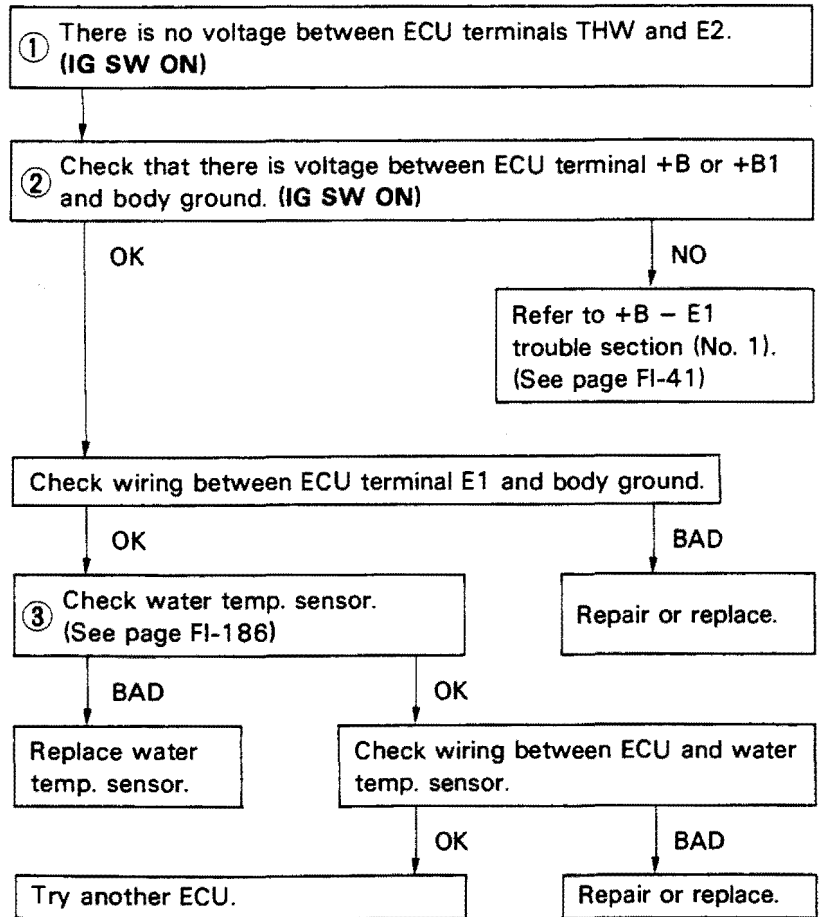

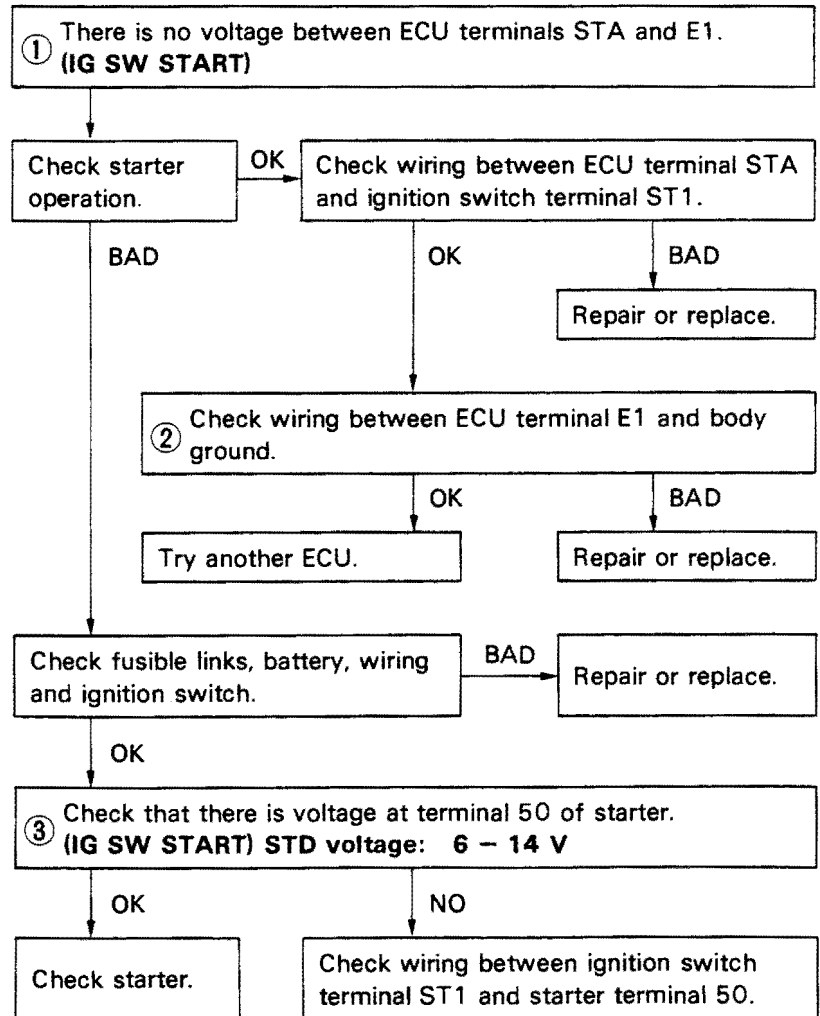
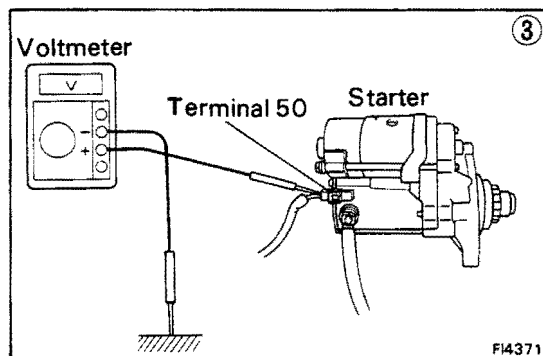
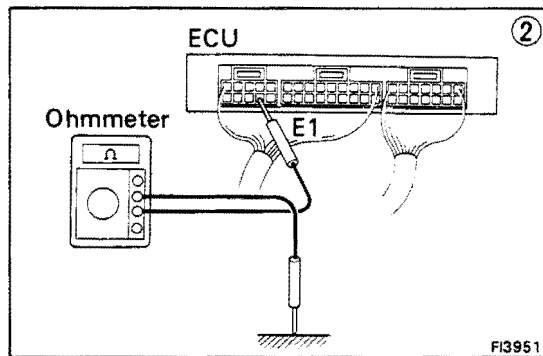
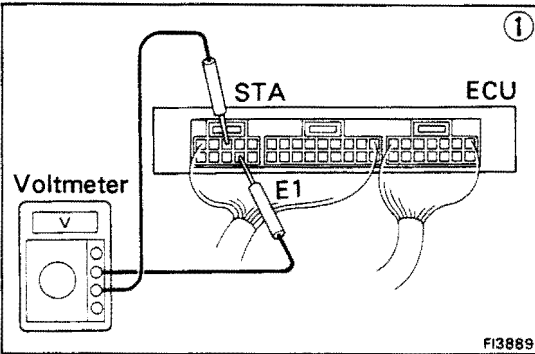
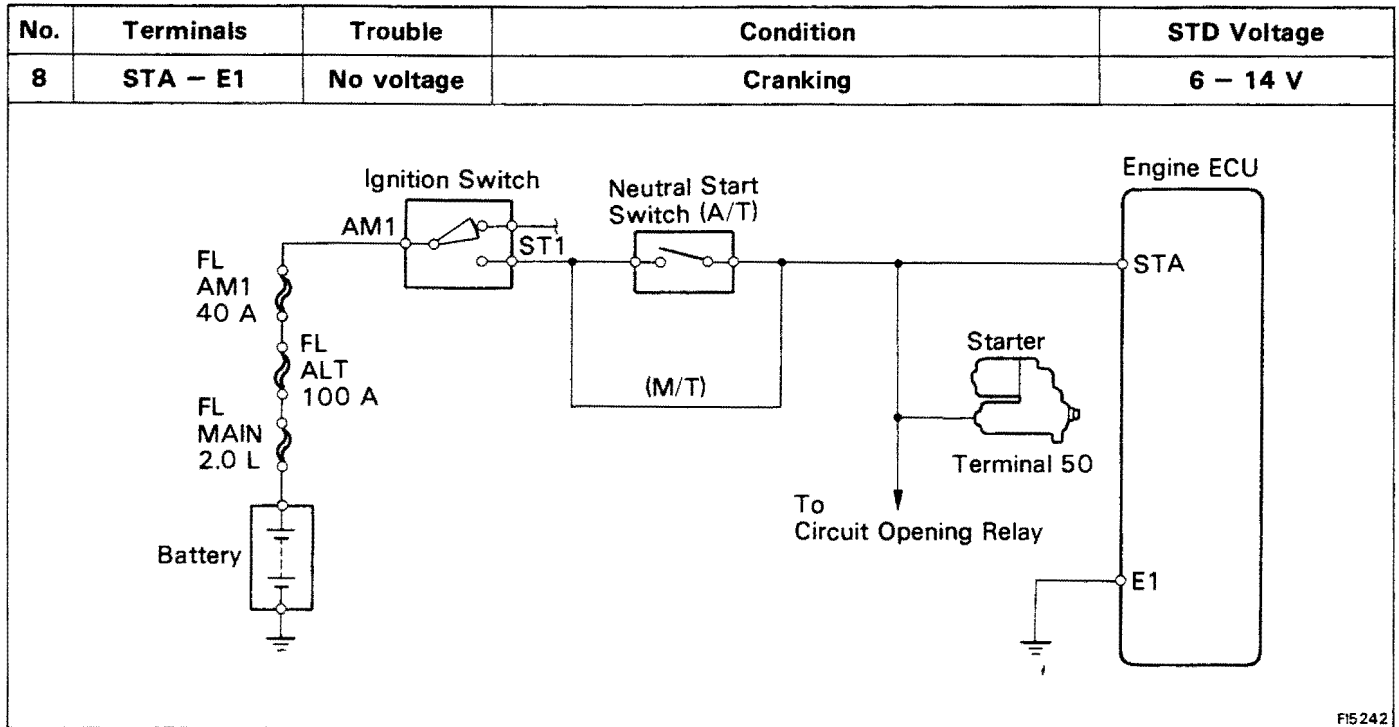

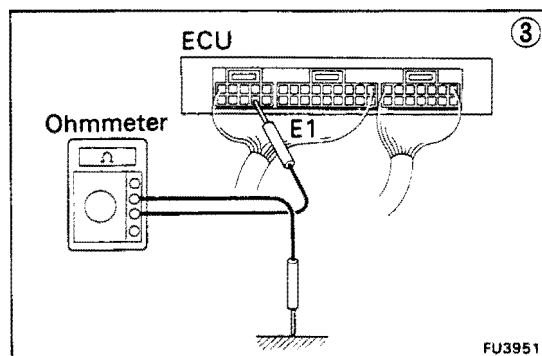
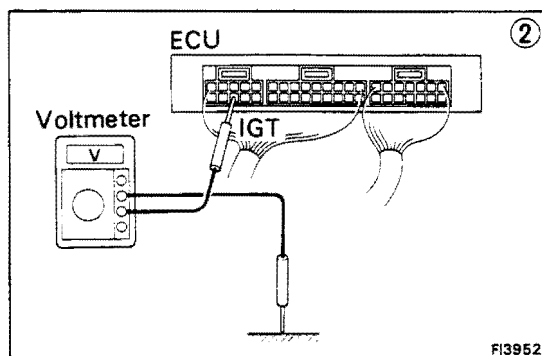
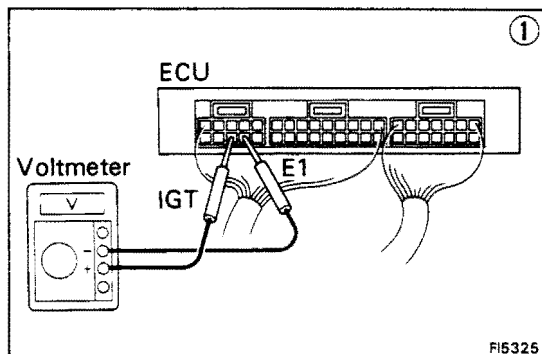
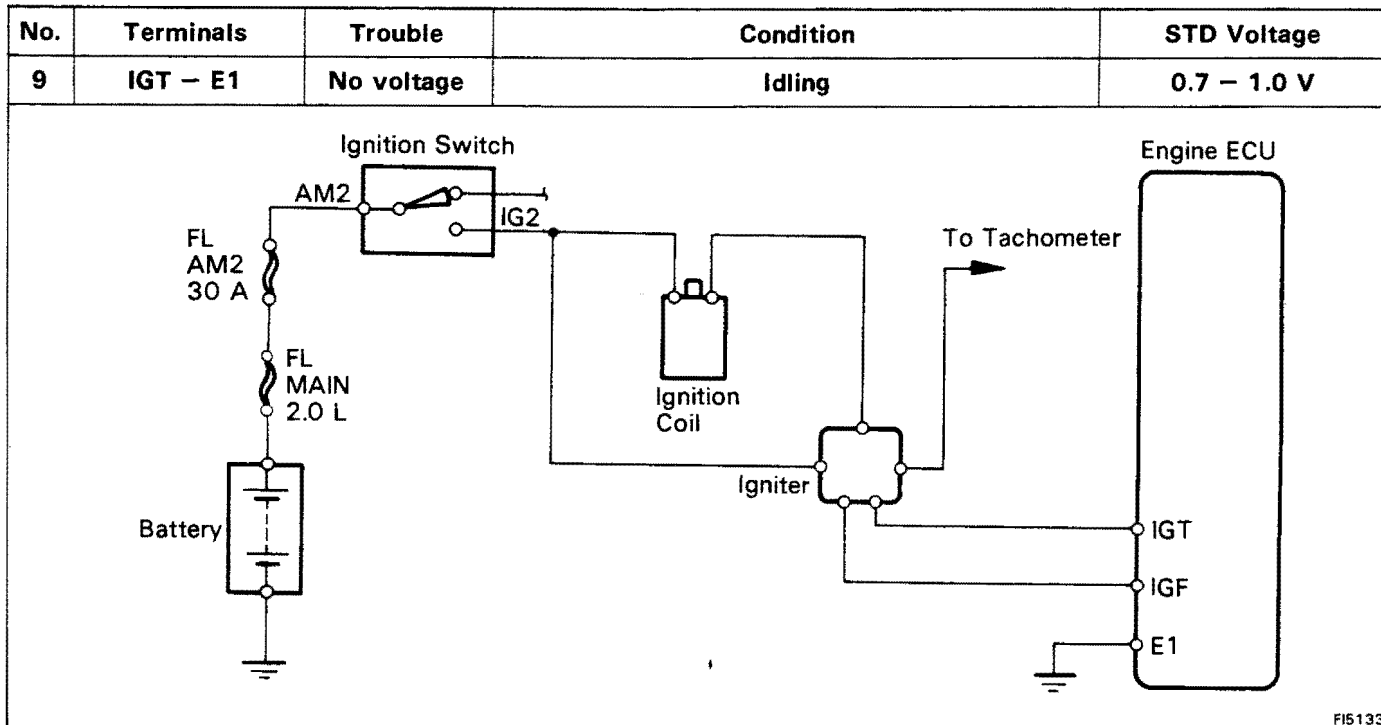

```

    graph TD
      Step1["① There is no voltage between ECU terminals IGT and E1. (Idling)"]
      Step2["② Check that there is voltage between ECU terminal IGT and body ground. (Idling)"]
      Step3["③ Check wiring between ECU terminal E1 and body ground."]
      Step4["Check fusible links and ignition switch."]
      Step5["Check distributor. (See page IG-11)"]
      Step6["Check wiring between ECU and battery."]
      Step7["Check igniter. (See page IG-12)"]
      Step8["Repair or replace."]
      Step9["Try another ECU."]

      Step1 --> Step2
      Step2 -- NO --> Step4
      Step2 -- OK --> Step3
      Step3 -- BAD --> Step8
      Step3 -- OK --> Step9
      Step4 -- BAD --> Step8
      Step4 -- OK --> Step5
      Step5 -- BAD --> Step8
      Step5 -- OK --> Step6
      Step6 -- BAD --> Step8
      Step6 -- OK --> Step7
      Step7 -- BAD --> Step8
      Step7 -- OK --> End[" "]
  
```

No.	Terminals	Trouble	Condition		STD Voltage
10	ISCC — E1 ISCO	No voltage	IG SW ON	Engine ECU connectors disconnected	8 — 14 V

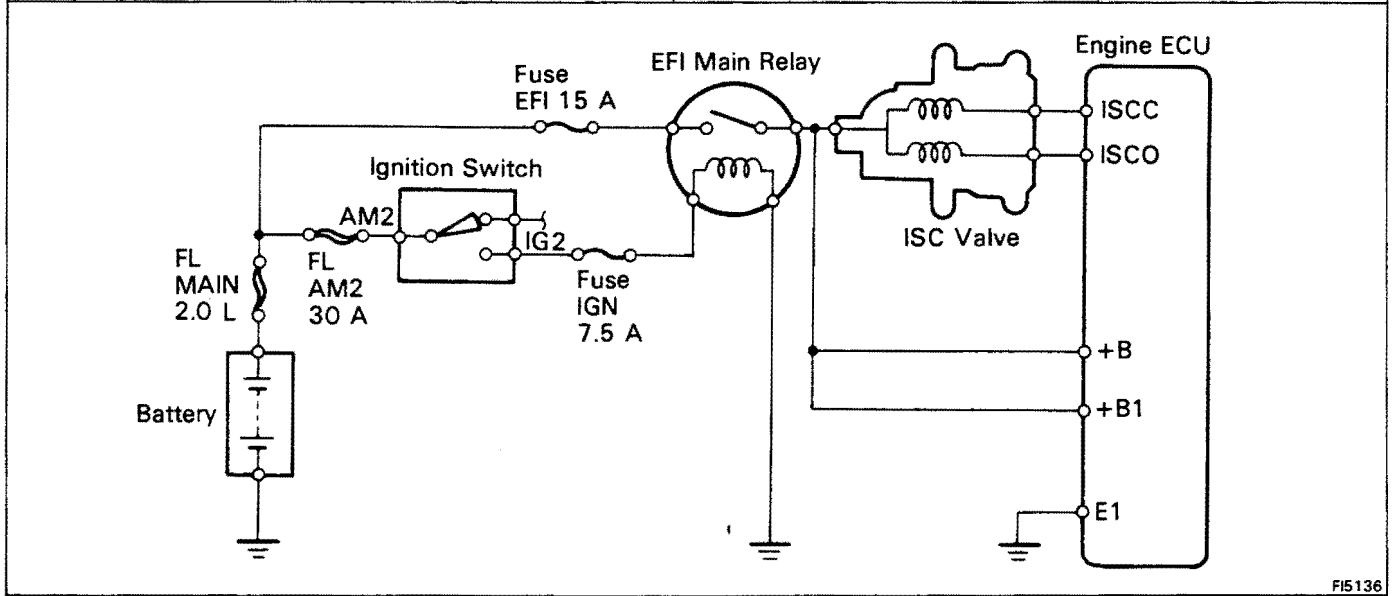

FI5136

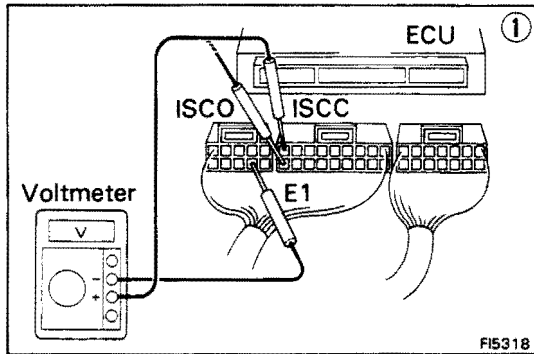

FI5318

① There is no voltage between ECU terminals ISCC or ISCO and E1. (IG SW ON)

② Check that there is voltage between ECU terminal +B or +B1 and body ground. (IG SW ON)

OK

NO

Refer to +B — E1 trouble section (No.1). (See page FI-41)

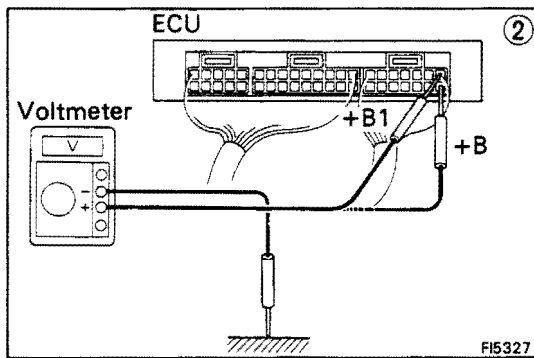

FI5327

Check resistance between ISC valve terminals +B and ISCC or ISCO.  
③ STD resistance: Approx. 19.3 — 22.3 Ω

BAD

Replace ISC valve.

OK

Check wiring between ECU and ISC valve.

BAD

Repair or replace.

OK

Try another ECU.

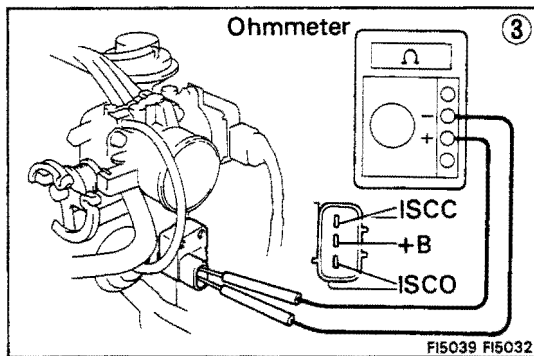

FI5039 FI5032

No.	Terminals	Trouble	Condition	STD Voltage
11	W – E1	No voltage	No trouble ("CHECK" engine warning light off) and engine running.	10 – 14 V

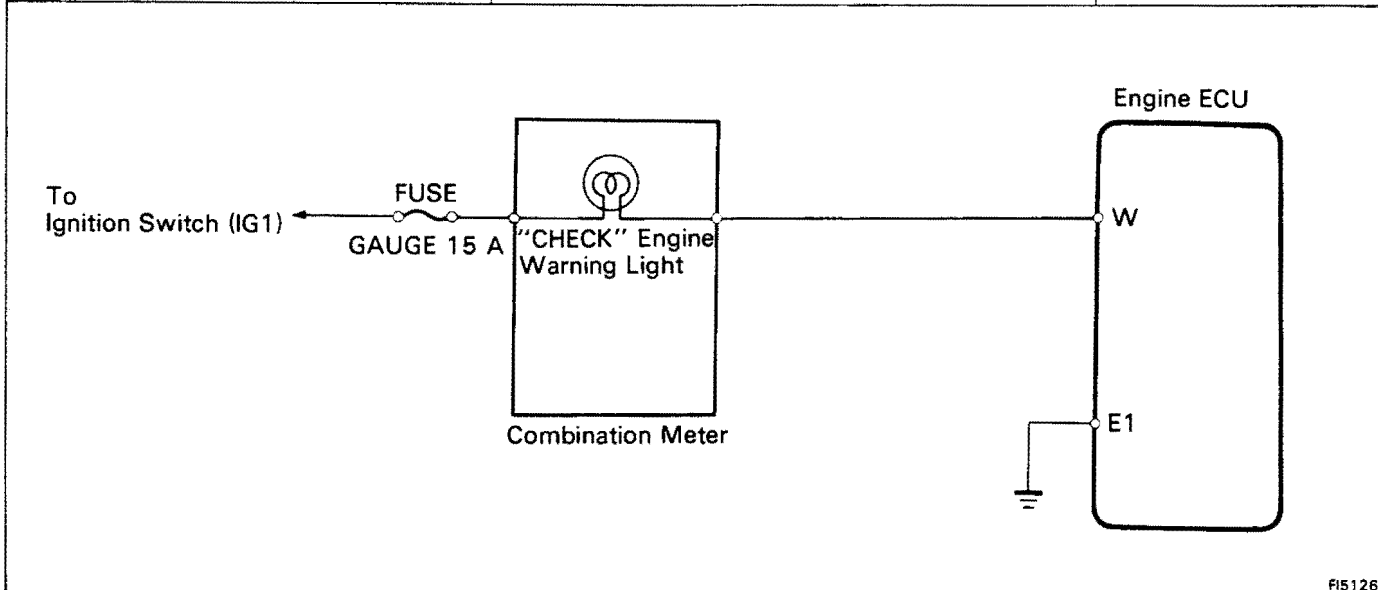

FI5126

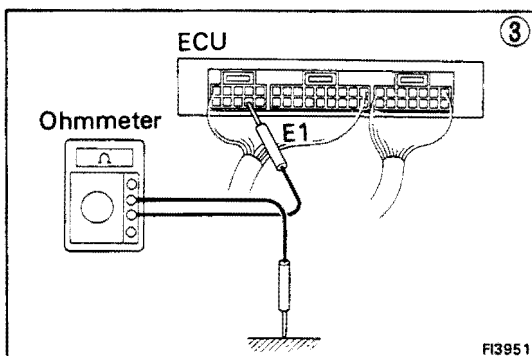
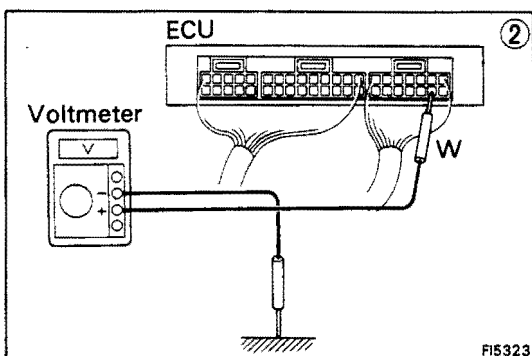
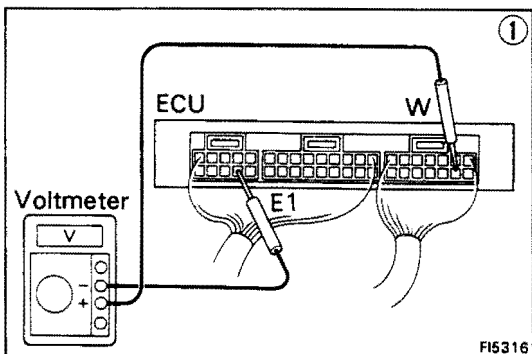

```

    graph TD
      Step1["① There is no voltage between ECU terminals W and E1.  
(Idling)"] --> Step2["② Check that there is voltage between ECU terminal W and body ground."]
      Step2 -- NO --> FuseCheck["Check GAUGE fuse (15 A) and 'CHECK' engine warning light."]
      Step2 -- OK --> Step3["③ Check wiring between ECU terminal E1 and body ground."]
      Step3 -- OK --> TryECU["Try another ECU."]
      Step3 -- BAD --> RepairECU["Repair or replace."]
      FuseCheck -- OK --> Step3
      FuseCheck -- BAD --> RepairFuse["Repair or replace."]
      RepairFuse -- Fuse blows again --> FuseWiring["Check wiring between ECU terminal W and fuse."]
      FuseWiring -- BAD --> RepairWiring["Repair or replace."]
  
```

No.	Terminals	Trouble	Condition	STD Voltage
12	A/C — E1	No voltage	Air conditioning ON	8 — 14 V

FI0922

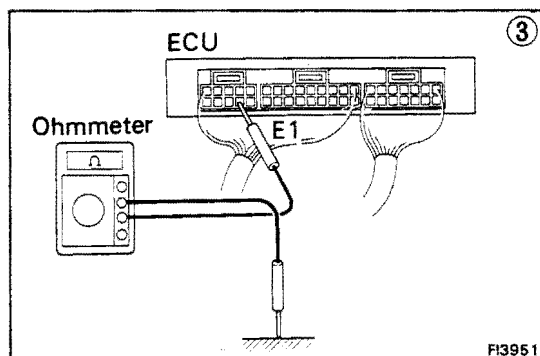
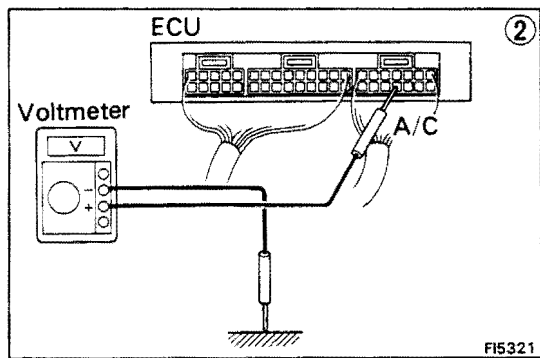
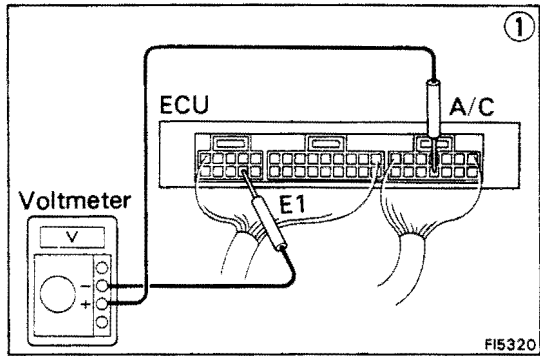

```

    graph TD
      Step1["① There is no voltage between ECU terminals A/C and E1.  
(Air conditioning ON)"] --> Step2["② Check that there is voltage between ECU terminal A/C and  
body ground."]
      Step2 -- NO --> Step3["③ Check wiring between ECU terminal E1 and body ground."]
      Step2 -- OK --> Step4["Try another ECU."]
      Step3 -- BAD --> Step3a["Repair or replace."]
      Step3 -- OK --> Step4
      Step4 --> Step5["Check compressor running."]
      Step5 -- OK --> Step6["Check wiring between ECU terminal A/C  
and amplifier."]
      Step5 -- BAD --> Step7["Check that there is voltage  
between amplifier terminal and  
body ground."]
      Step6 -- BAD --> Step6a["Repair or replace."]
      Step6 -- OK --> Step7
      Step7 -- BAD --> Step7a["Repair or replace."]
      Step7 -- OK --> Step8["Check wiring between amplifier  
and ECU or compressor."]
      Step8 -- BAD --> Step8a["Repair or replace."]
      Step8 -- OK --> End[" "]
  
```



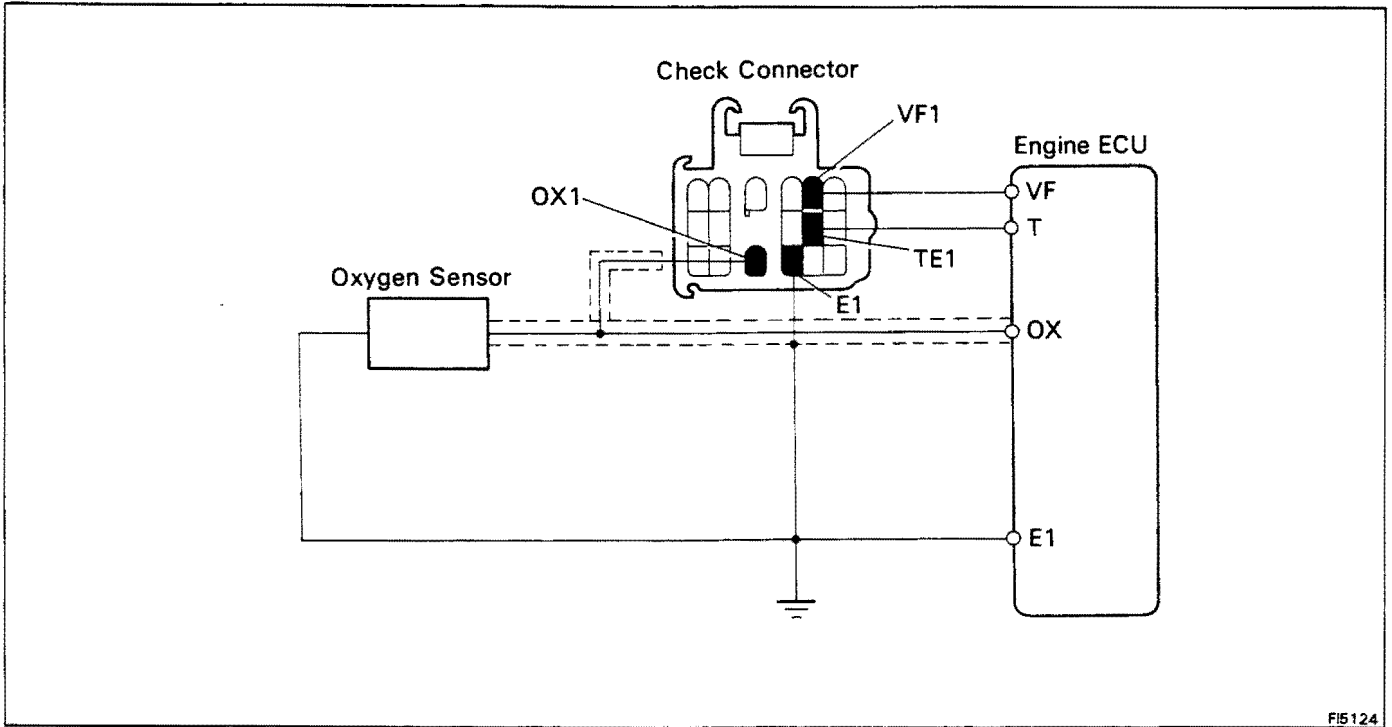

FI5124

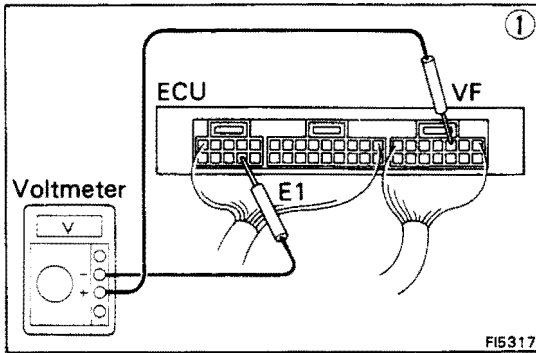

FI5317

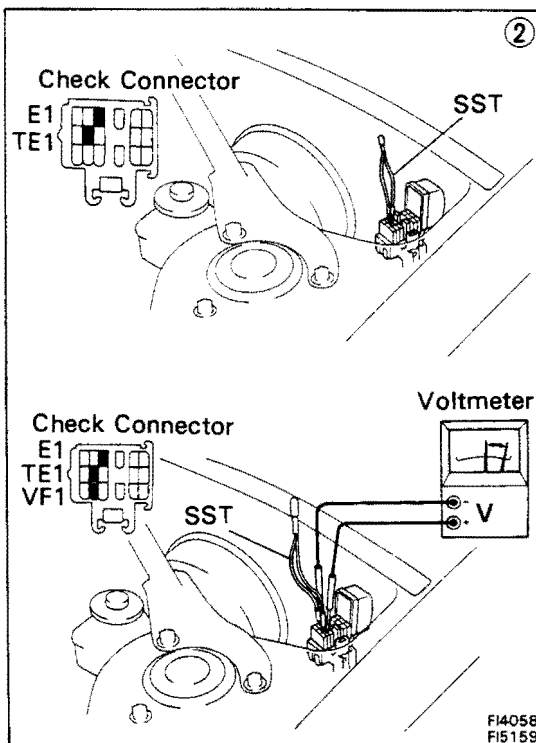

FI4058  
FI5159

```

    graph TD
        A["① There is no voltage between ECU terminals VF and E1."] --> B["Check that there is voltage between ECU terminal VF and body ground."]
        B -- NO --> C["Is air leaking into air induction system?"]
        B -- OK --> D["Check wiring between ECU terminal E1 and body ground."]
        D -- OK --> E["Try another ECU."]
        D -- BAD --> F["Repair or replace."]
        E -- BAD --> F
        C -- BAD --> F
        C -- OK --> G["Check spark plugs. (See page IG-7)"]
        G -- BAD --> F
        G -- OK --> H["Check distributor and ignition system. (See page IG-4)"]
        H -- BAD --> F
        H -- OK --> I["Check fuel pressure. (See page FI-103)"]
        I -- BAD --> F
        I -- OK --> J["Check injectorts. (See page FI-134)"]
        J -- BAD --> F
        J -- OK --> K["* Check cold start injector. (See page FI-118)"]
        K -- BAD --> F
        K -- OK --> L["Check vacuum sensor. (See page FI-136)"]
        L -- BAD --> F
        L -- OK --> M["② Check operation of oxygen sensor. (See page FI-201)"]
        M -- OK --> N["System normal."]
        M -- BAD --> O["Check wiring between oxygen sensor and ECU."]
        O -- BAD --> P["Repair wiring."]
        O -- OK --> Q["Replace oxygen sensor."]
    
```

\* Rich malfunction only

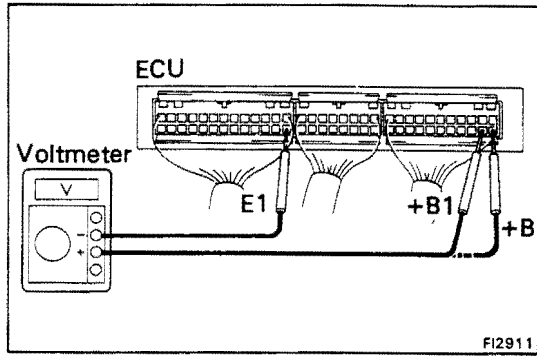

### EFI SYSTEM CHECK PROCEDURE (5S-FE w/ ECT)

**HINT:**

- Perform all voltage measurements with the connectors connected. (ex. Code No.10)
- Verify that the battery voltage is 11 V or more when the ignition switch is in "ON" position.

Using a voltmeter with high impedance (10 kΩ/V minimum), measure the voltage at each terminal of the wiring connectors.

### Terminals of Engine and ECT ECU (5S-FE w/ ECT)

Symbol	Terminal name	Symbol	Terminal name	Symbol	Terminal name
E01	POWER GROUND	P	PATTERN SELECT SWITCH	NSW	NEUTRAL START SWITCH
E02	POWER GROUND	G1	DISTRIBUTOR	A/C	A/C MAGNET SWITCH
No.10	INJECTOR	NE	DISTRIBUTOR	ACT	A/C AMPLIFIER
/	-	E1	ENGINE GROUND	SP1	SPEED SENSOR (Meter side)
No.20	INJECTOR	VF	CHECK CONNECTOR	OD1	CRUISE CONTROL ECU
/	-	G ⊖	DISTRIBUTOR	ACA	A/C AMPLIFIER
ISCO	ISC VALVE	DG	CHECK CONNECTOR	/	-
EGR	EGR VSV	T	CHECK CONNECTOR	OD2	CRUISE CONTROL MAIN SWITCH
ISCC	ISC VALVE	OX1	OXYGEN SENSOR	/	-
/	-	/	-	/	-
/	-	/	-	/	-
/	-	/	-	W	WARNING LIGHT
/	-	THW	WATER TEMP. SENSOR	/	-
IGT	IGNITER	IDL	THROTTLE POSITION	B/K	STOP LIGHT SWITCH
S1	ECT SOLENOID	THA	AIR TEMP. SENSOR	/	-
L	NEUTRAL START SWITCH	VTA	THROTTLE POSITION SENSOR	/	-
S2	ECT SOLENOID	PIM	VACUUM SENSOR	FC	CIRCUIT OPENING RELAY
2	NEUTRAL START SWITCH	/	-	ELS	TAILLIGHT RELAY, DEFOGGER RELAY
SL	ECT SOLENOID	VC	VACUUM SENSOR, THROTTLE POSITION SENSOR	+B1	MAIN RELAY
SP2	SPEED SENSOR (A/T side)	E2	SENSOR GROUND	BATT	BATTERY
IGF	IGNITER	STA	STARTER SWITCH	+B	MAIN RELAY
E21	SENSOR GROUND				

**Engine and ECT ECU Terminals**

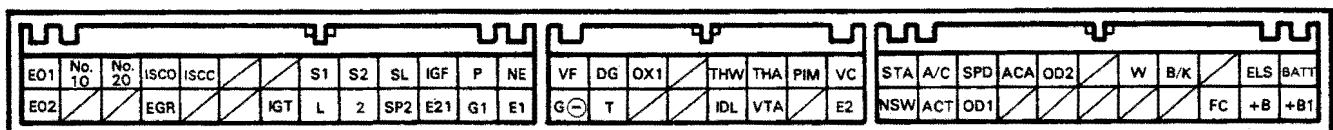

**Voltage at Engine and ECT ECU Wiring Connectors (5S-FE w/ ECT)**

No.	Terminals	Condition		STD voltage (V)	See page
1	+B +B1 - E1	IG SW ON		10 - 14	FI-56
2	BATT - E1	-		10 - 14	FI-57
3	IDL - E2	IG SW ON	Throttle valve open	8 - 14	FI-58
	VC - E2		-	4 - 6	
	VTA - E2		Throttle valve fully closed (Throttle opener must be cancelled first)	0.1 - 1.0	
			Throttle valve open	4 - 5	
4	PIM - E2	IG SW ON		2.5 - 4.5	FI-60
	VC - E2			4 - 6	
5	No.10 - E01 No.20 - E02	IG SW ON		10 - 14	FI-61
6	THA - E2	IG SW ON	Intake air temp. 20°C (68°F)	1 - 3	FI-62
7	THW - E2		Coolant temp. 80°C (176°F)	0.1 - 1.0	FI-63
8	STA - E1	Cranking		6 - 14	FI-64
9	IGT - E1	Idling		0.7 - 1.0	FI-65
10	ISCC ISCO - E1	IG SW ON	Engine and ECT ECU connectors disconnected	8 - 14	FI-66
11	W - E1	No trouble ("CHECK" engine warning light off) and engine running		10 - 14	FI-67
12	A/C - E1	IG SW ON	Air conditioning ON	8 - 14	FI-68

**Engine and ECT ECU Terminals**

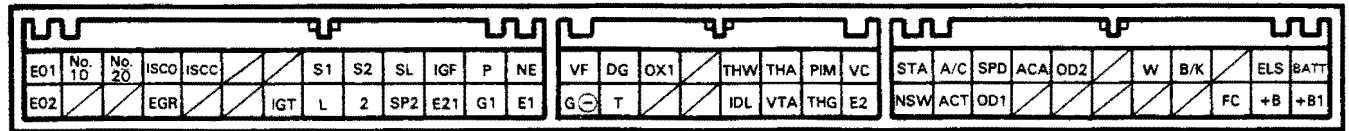

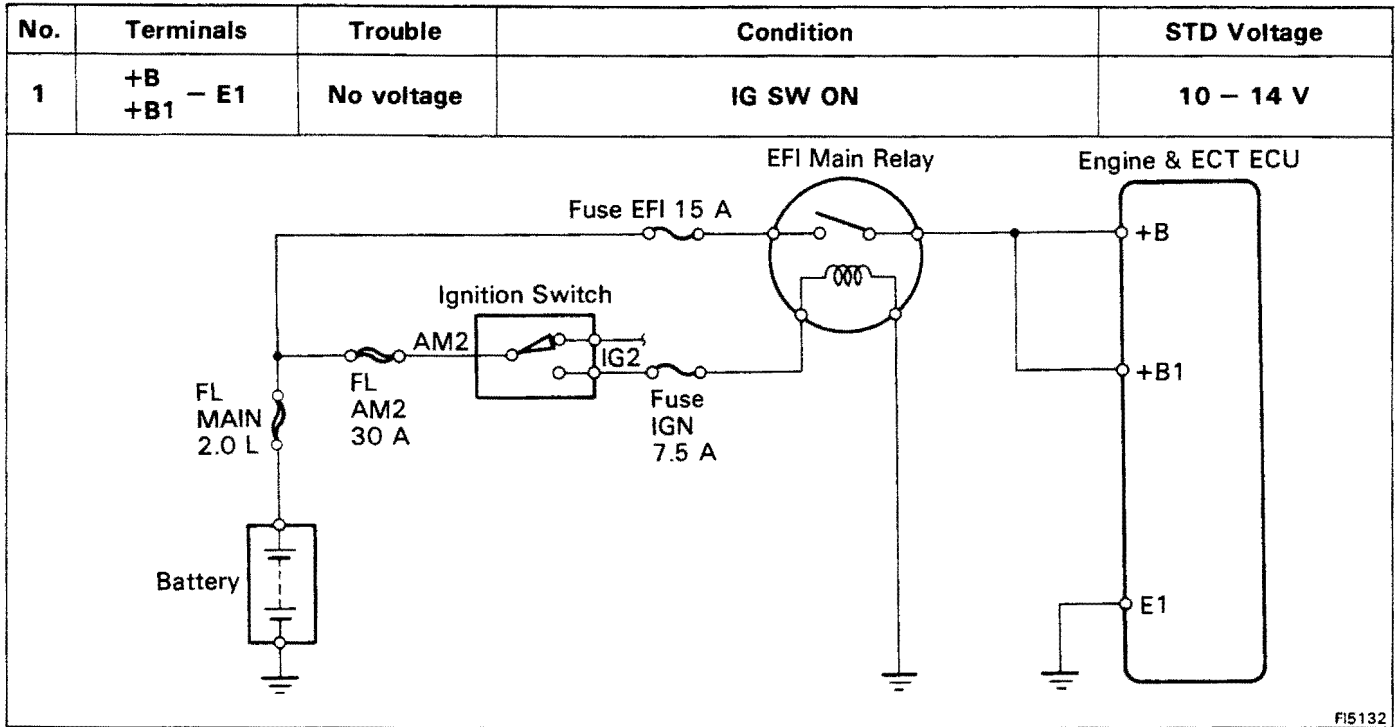

FI5132

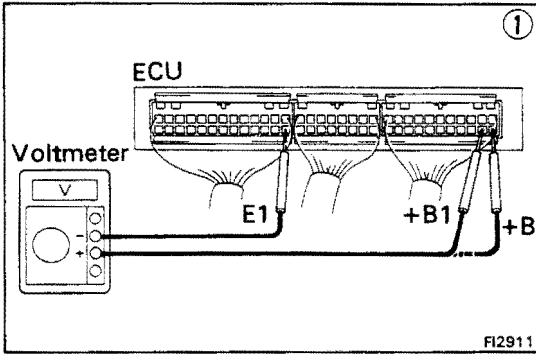

FI2911

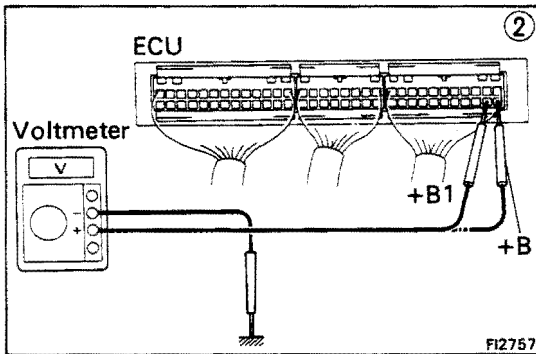

FI2757

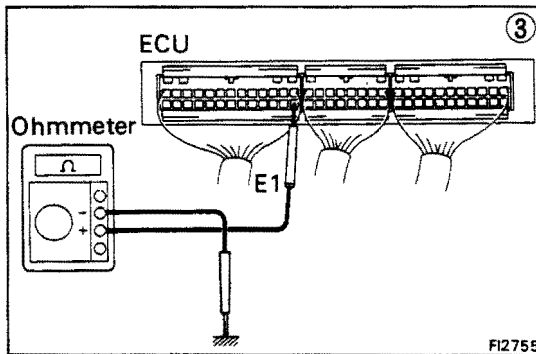

FI2755

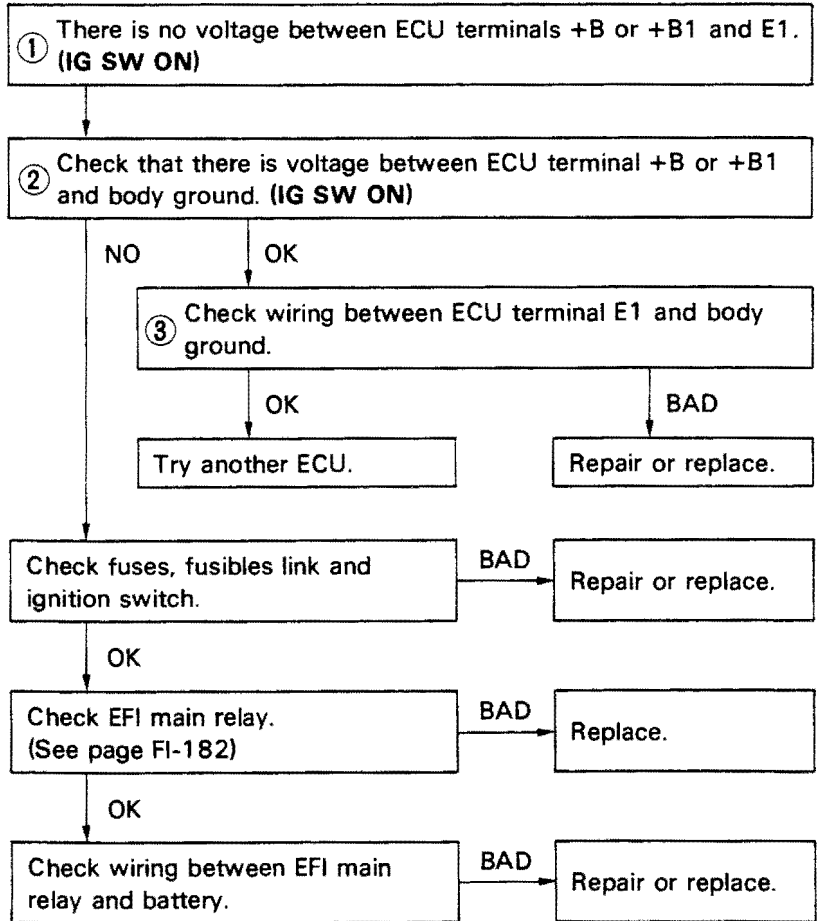

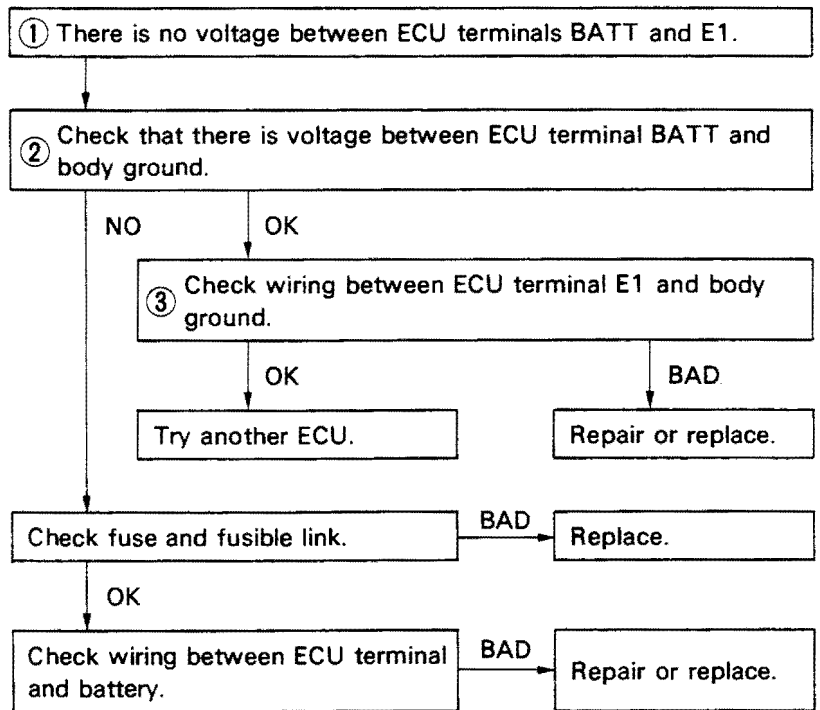
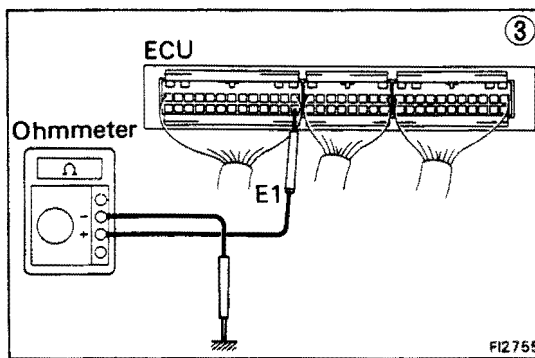
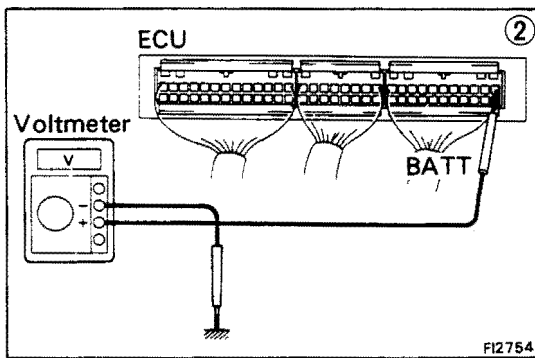
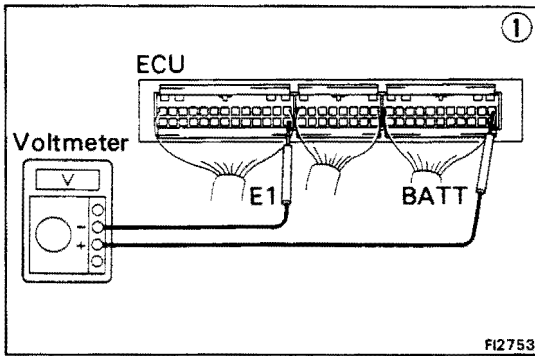
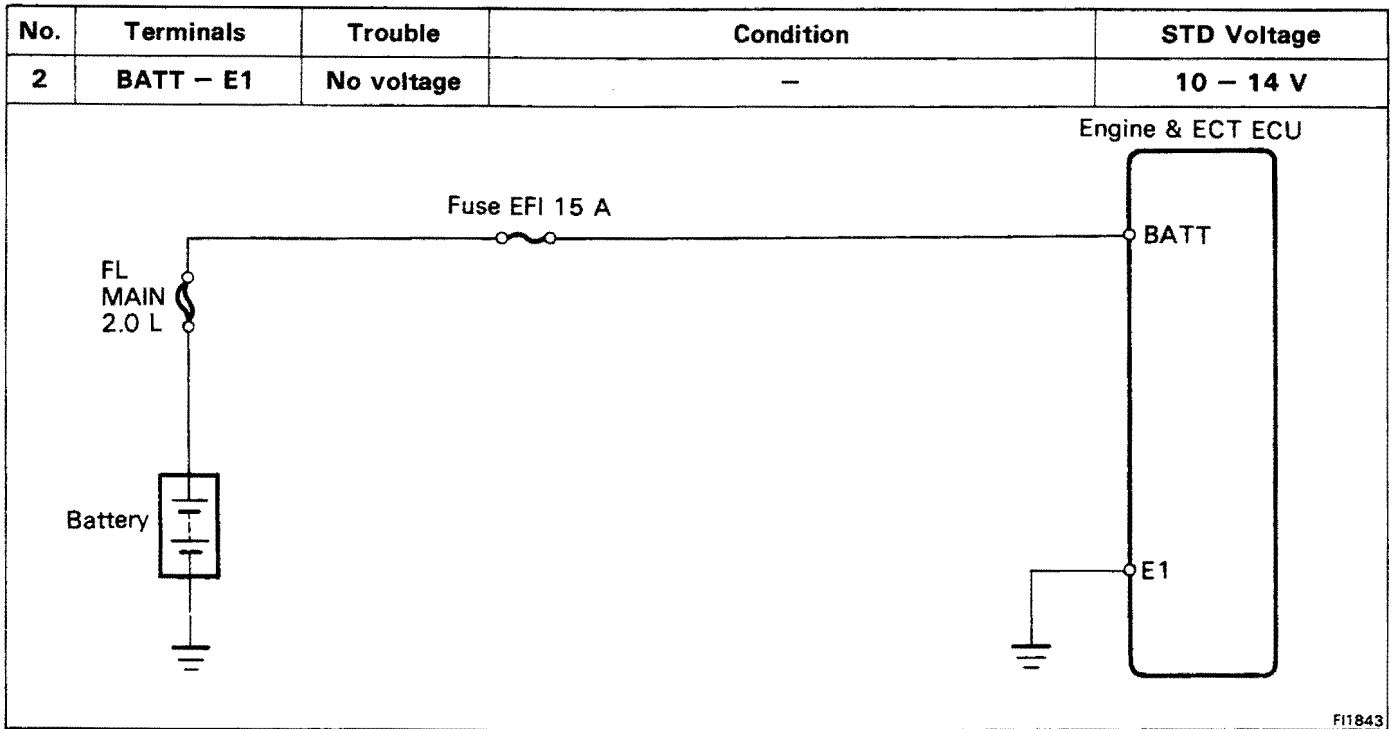

No.	Terminals	Trouble	Condition	STD Voltage	
3	IDL - E2	No Voltage	Ignition switch ON	Throttle valve open	8 - 14 V
	VC - E2			-	4 - 6 V
	VTA - E2			Throttle valve fully closed (Throttle opener must be cancelled first)	0.1 - 1.0 V
				Throttle valve fully open	4 - 5 V

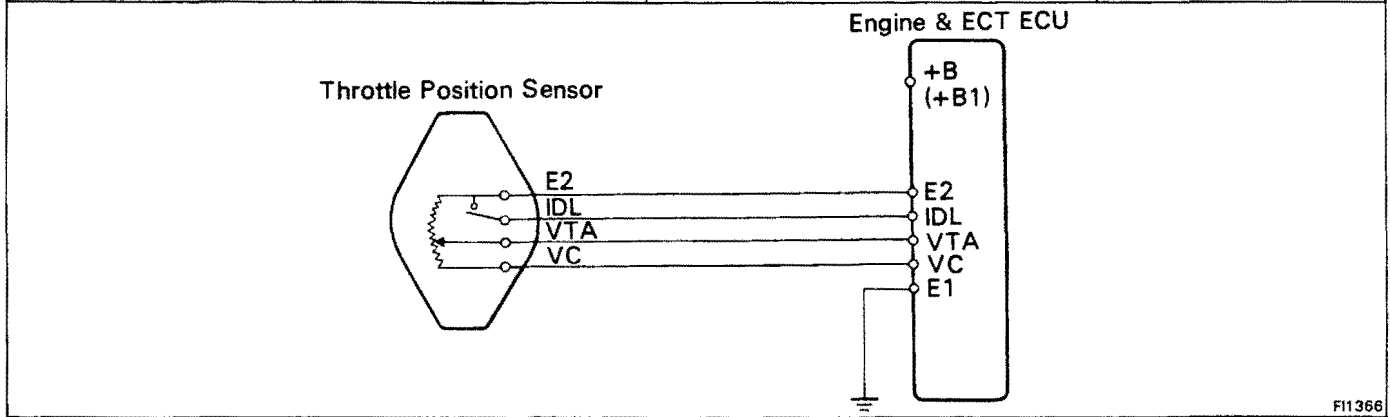

F11366

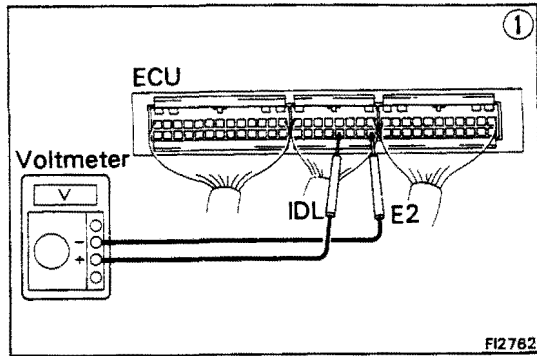

FI2762

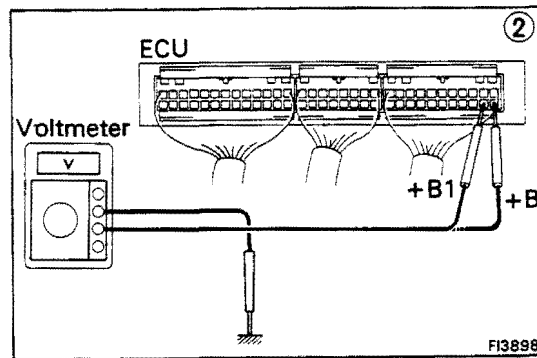

FI3898

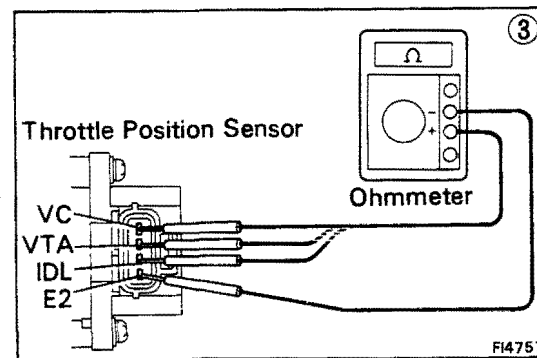

FI4757

• IDL - E2

① There is no voltage between ECU terminals IDL and E2. (IG SW ON) (Throttle valve open)

② Check that there is voltage between ECU terminal +B or +B1 and body ground. (IG SW ON)

NO

OK

Check wiring between ECU terminal E1 and body ground.

OK

BAD

Try another ECU.

Repair or replace.

Refer to +B - E1 trouble section (No.1). (See page FI-56)

BAD

Repair or replace.

OK

③ Check throttle position sensor. (See page FI-163)

BAD

Repair or replace throttle position sensor.

OK

Check wiring between ECU and throttle position sensor.

BAD

OK

Try another ECU.

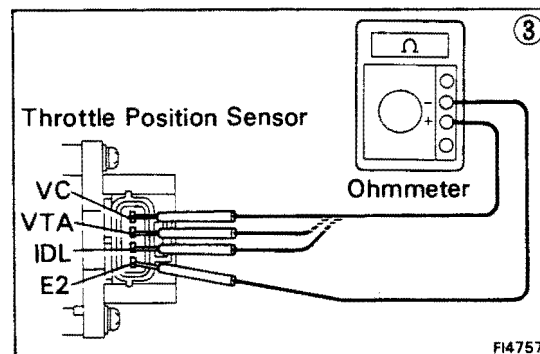
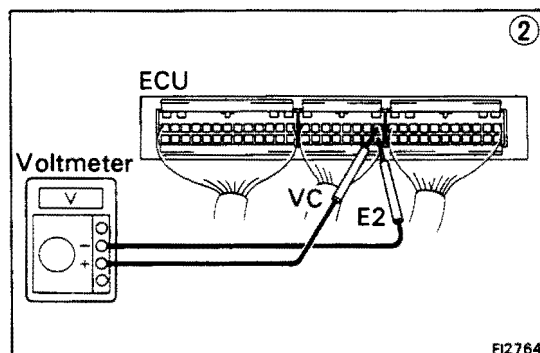
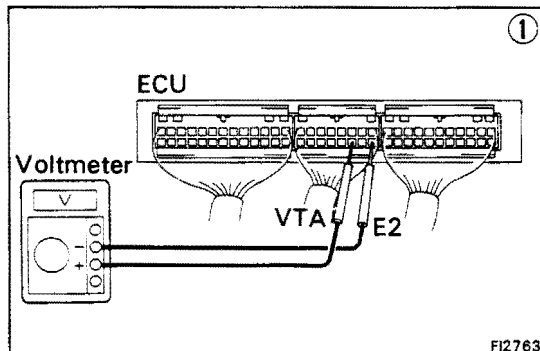
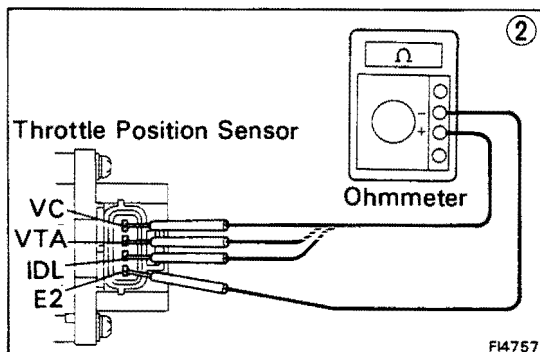
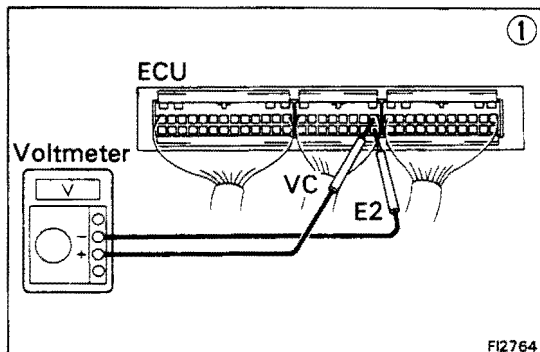

• VC – E2

```

    graph TD
      A["① No voltage between ECU terminals VC and E2.  
(IG SW ON)"] --> B["Check that there is voltage between ECU terminal +B or +B1 and  
body ground. (IG SW ON)"]
      B -- OK --> C["② Check throttle position  
sensor. (See page FI-163)"]
      B -- NO --> D["Refer to +B – E1 trouble  
Section (No.1).  
(See page FI-56)"]
      C -- BAD --> E["Repair or replace."]
      C -- OK --> F["Check wiring between ECU and throttle  
position sensor."]
      F -- OK --> G["Try another ECU."]
      F -- BAD --> H["Repair or replace  
wiring."]
    
```

• VTA – E2

```

    graph TD
      A["① No specified voltage at ECU terminals VTA and E2.  
(IG SW ON)"] --> B["② Check that there is voltage between ECU terminals VC and E2.  
(IG SW ON)"]
      B -- NO --> C["Refer to VC – E2  
trouble section."]
      B -- OK --> D["③ Check throttle position sensor.  
(See page FI-163)"]
      D -- BAD --> E["Repair or replace."]
      D -- OK --> F["Check wiring between ECU and  
throttle position sensor."]
      F -- BAD --> G["Repair or replace."]
      F -- OK --> H["Try another ECU."]
    
```

No.	Terminals	Trouble	Condition	STD Voltage
4	PIM – E2	No voltage	IG SW ON	2.5 – 4.5 V
	VC – E2			4 – 6 V

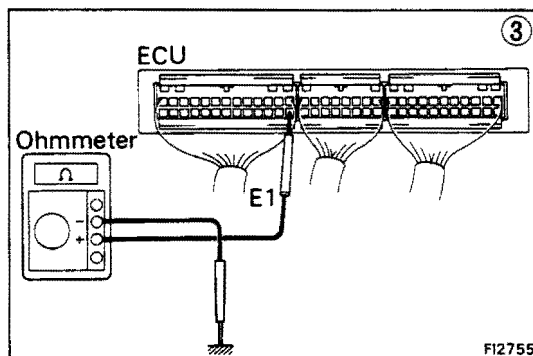
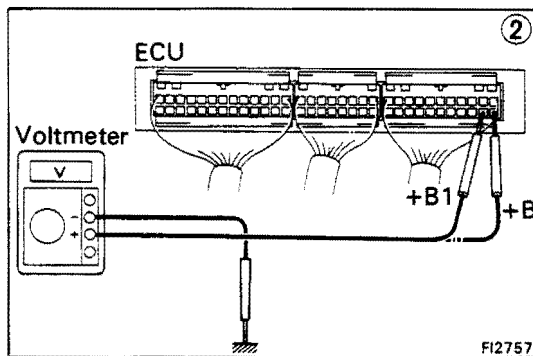
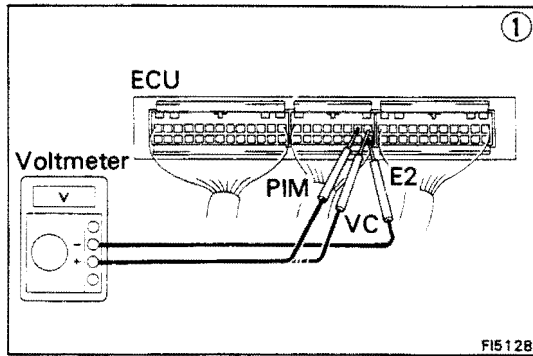
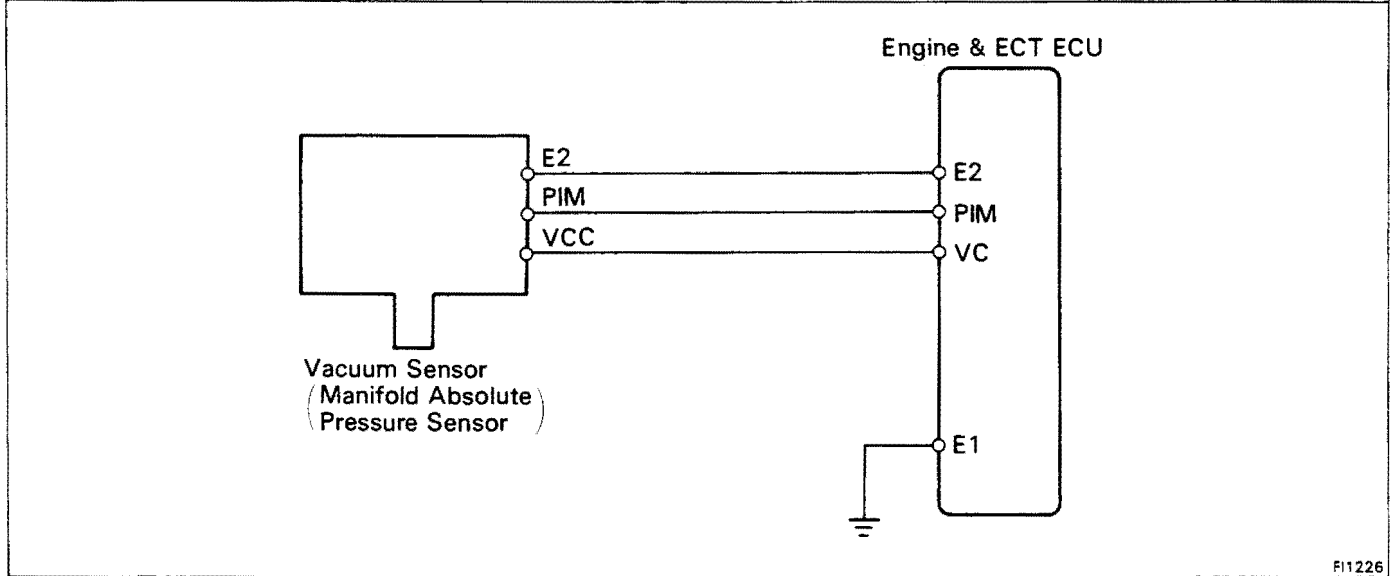

```

    graph TD
      Step1["① There is no voltage between ECU terminals PIM or VC and E2.  
(IG SW ON)"] --> Step2["② Check that there is voltage between ECU terminal +B or +B1  
and body ground. (IG SW ON)"]
      Step2 -- OK --> Step3["③ Check wiring between ECU terminal E1 and body ground."]
      Step2 -- NO --> Ref["Refer to +B – E1  
trouble section (No.1).  
(See page FI-56)"]
      Step3 -- OK --> CheckSensor["Check vacuum sensor.  
(See page FI-189)"]
      Step3 -- BAD --> Repair1["Repair or replace."]
      CheckSensor -- BAD --> ReplaceSensor["Replace vacuum sensor."]
      CheckSensor -- OK --> CheckWiring["Check wiring between ECU and  
vacuum sensor."]
      CheckWiring -- OK --> TryECU["Try another ECU."]
      CheckWiring -- BAD --> Repair2["Repair or replace."]
    
```



No.	Terminals	Trouble	Condition	STD voltage
5	No.10 - E01 No.20 - E02	No voltage	Ignition switch ON	10 - 14 V

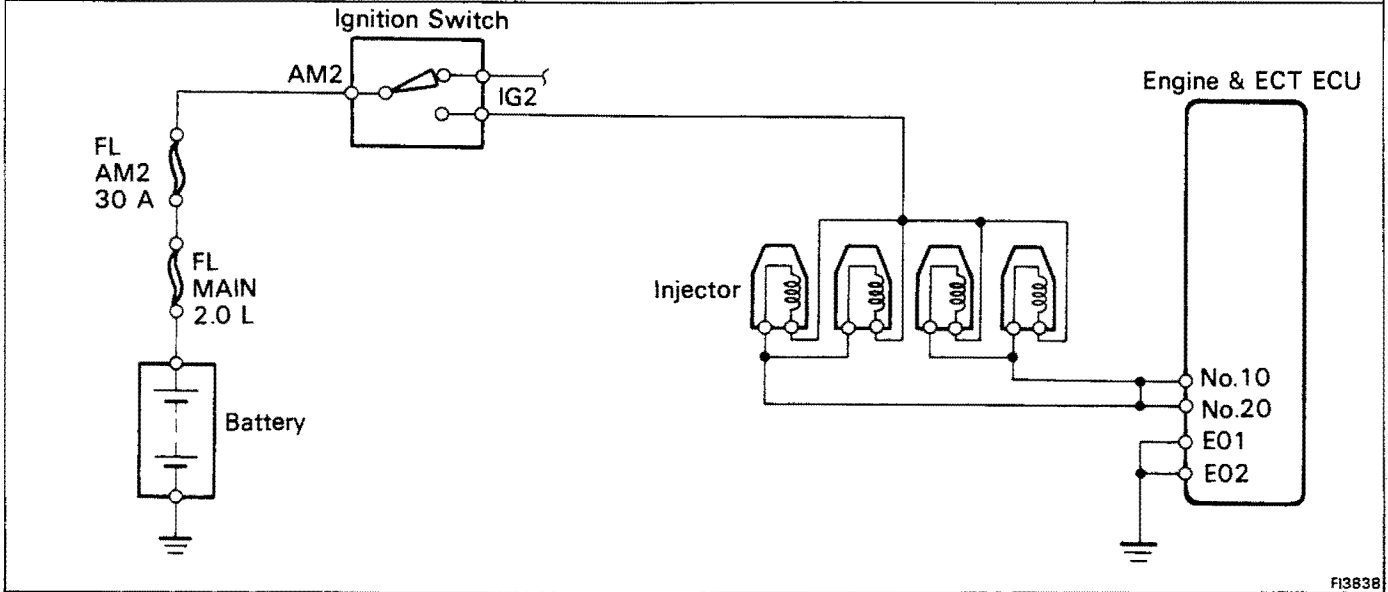

FI383B

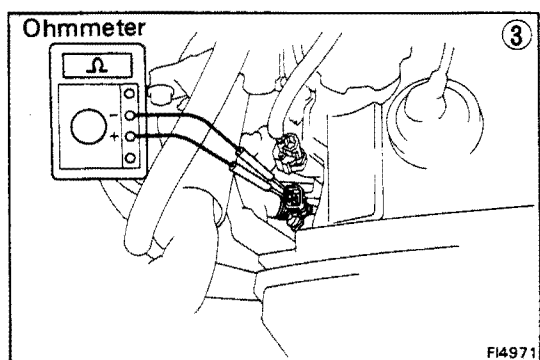
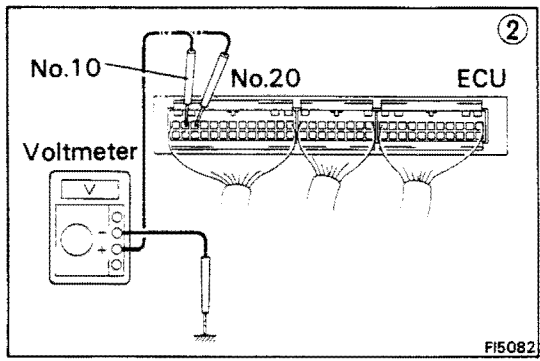
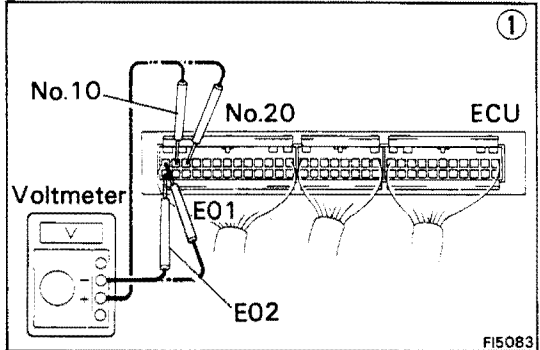

```

    graph TD
      Step1["① There is no voltage between ECU terminals No.10 and/or No.20 and E01 and/or E02. (IG SW ON)"]
      Step2["② Check that there is voltage between ECU terminal No.10 and/or No.20 and body ground."]
      Step3["③ Check resistance of each injector. STD resistance: Approx. 13.8 Ω"]
      
      Step1 --> Step2
      
      Step2 -- NO --> CheckFuses["Check fusible links and ignition switch."]
      Step2 -- OK --> CheckWiringECU["Check wiring between ECU terminal E01 and/or E02 and body ground."]
      
      CheckFuses -- BAD --> RepairFuses["Repair or replace."]
      CheckFuses -- OK --> Step3
      
      CheckWiringECU -- OK --> TryECU["Try another ECU."]
      CheckWiringECU -- BAD --> RepairECU["Repair or replace."]
      
      Step3 -- OK --> CheckWiringBattery["Check wiring between ECU terminal No.10 and/or No.20 and battery."]
      Step3 -- BAD --> ReplaceInjector["Replace injector."]
      
      CheckWiringBattery -- BAD --> RepairWiring["Repair or replace."]
      CheckWiringBattery -- OK --> End[" "]
  
```

No.	Terminals	Trouble	Condition		STD voltage
6	THA - E2	No voltage	IG SW ON	Intake air temperature 20°C (68°F)	1 - 3 V

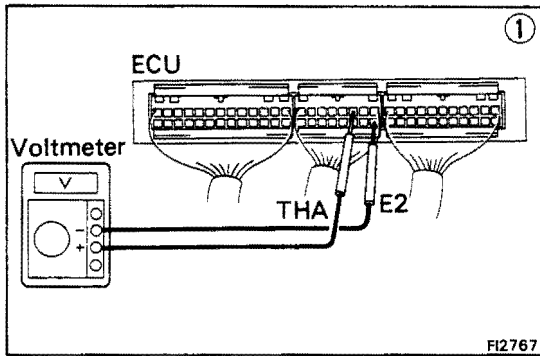
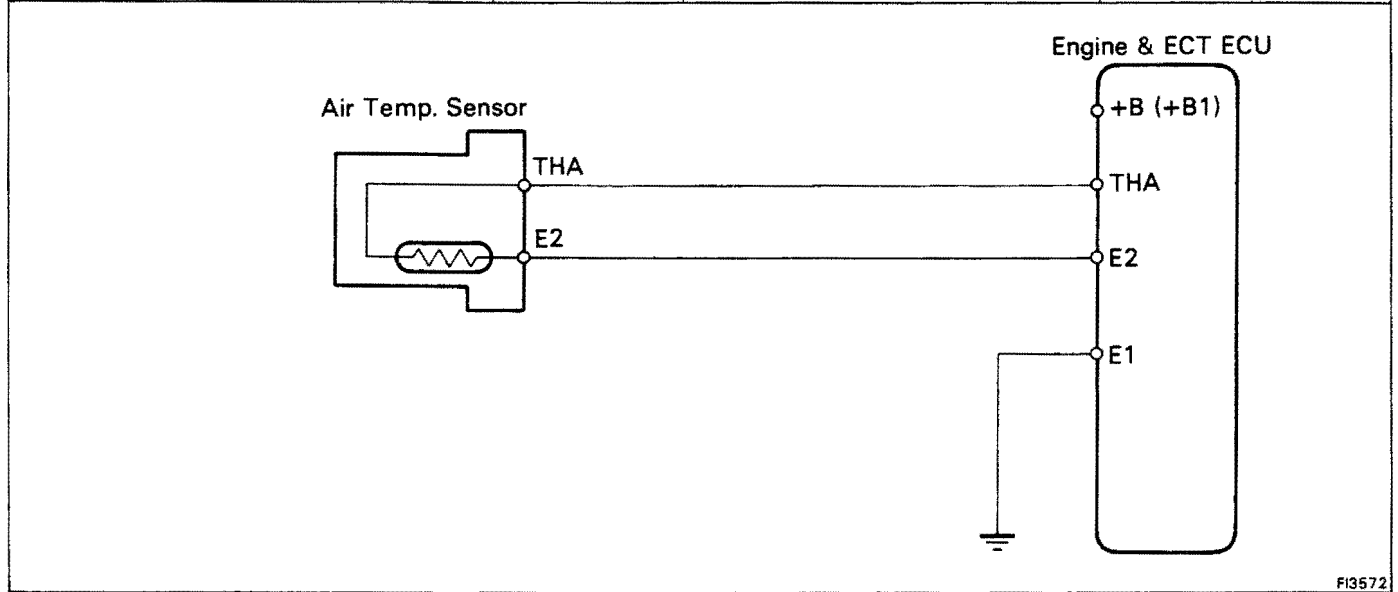

① There is no voltage between ECU terminals THA and E2. (IG SW ON)

② Check that there is voltage between ECU terminal +B or +B1 and body ground. (IG SW ON)

OK

NO

Refer to +B1 - E1 trouble section No.1. (See page FI-56)

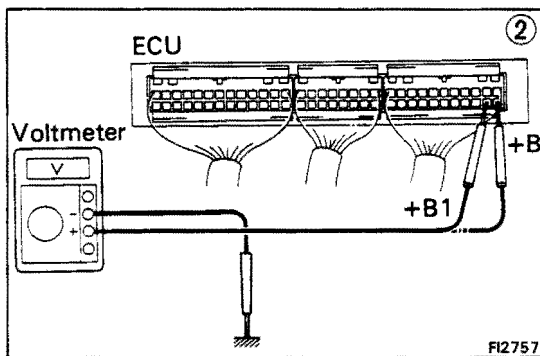

Check wiring between ECU terminal E1 and body ground.

OK

BAD

③ Check air temp. sensor. (See page FI-188)

Repair or replace.

BAD

OK

Repair air temp. sensor.

Check wiring between ECU and air temp. sensor.

OK

BAD

Try another ECU.

Repair or replace.

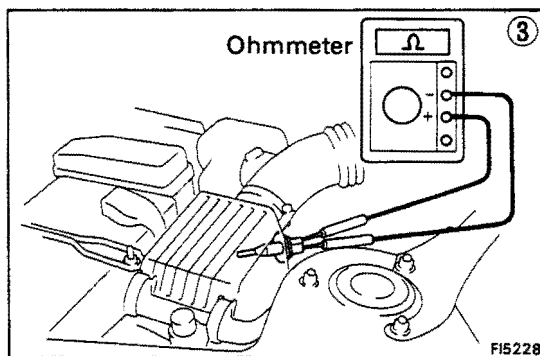

No.	Terminals	Trouble	Condition		STD voltage
			IG SW ON	Coolant temperature 80°C (176°F)	
7	THW — E2	No voltage	IG SW ON	Coolant temperature 80°C (176°F)	0.1 — 1.0 V

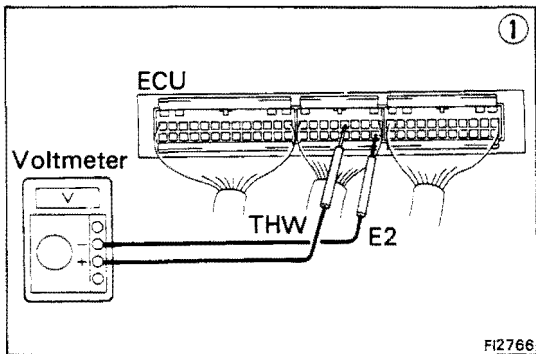
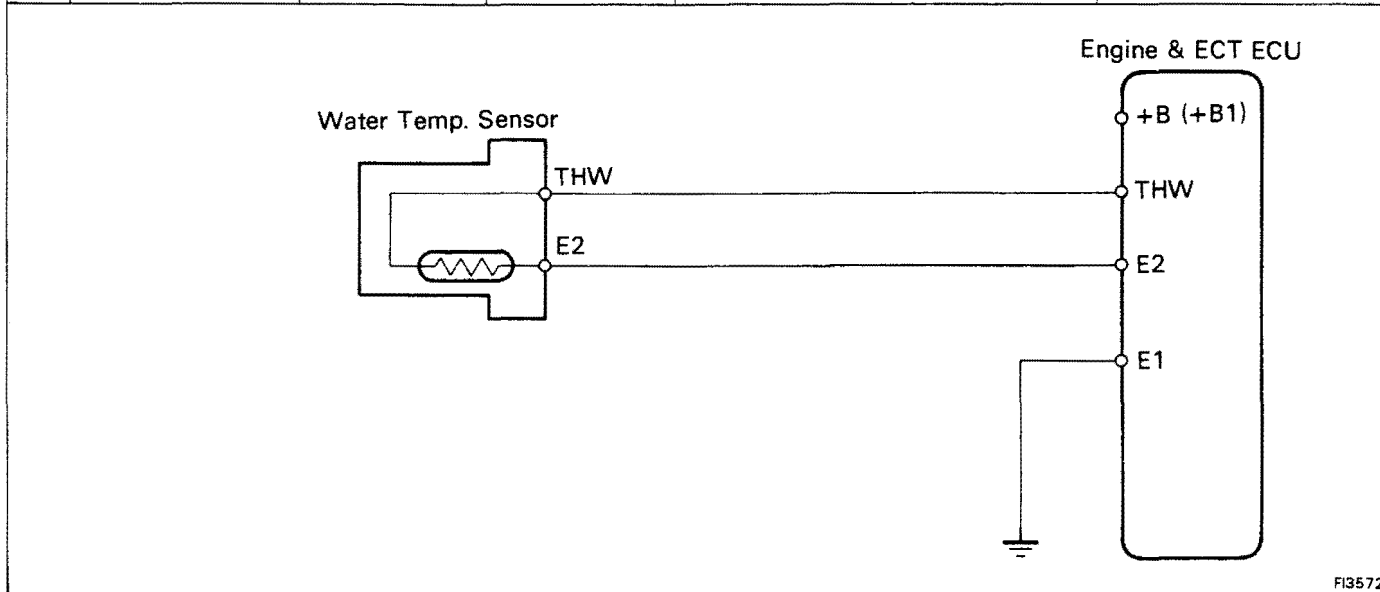

① There is no voltage between ECU terminals THW and E2. (IG SW ON)

② Check that there is voltage between ECU terminal +B or +B1 and body ground. (IG SW ON)

NO

Refer to +B — E1 trouble section (No.1) (See page FI-56)

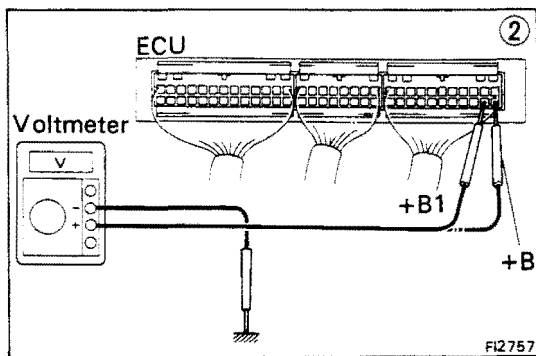

OK

Check wiring between ECU terminal E1 and body ground.

BAD

Repair or replace.

OK

③ Check water temp. sensor. (See page FI-186)

BAD

Replace water temp. sensor.

OK

Check wiring between ECU and water temp. sensor.

OK

Try another ECU.

BAD

Repair or replace.

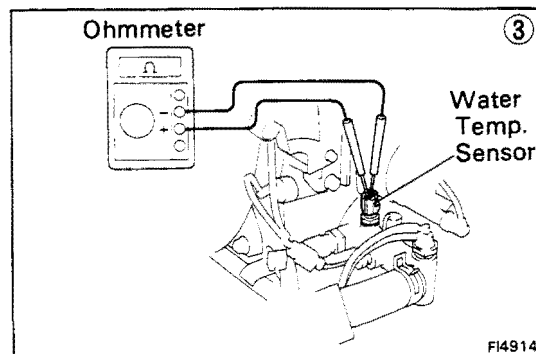

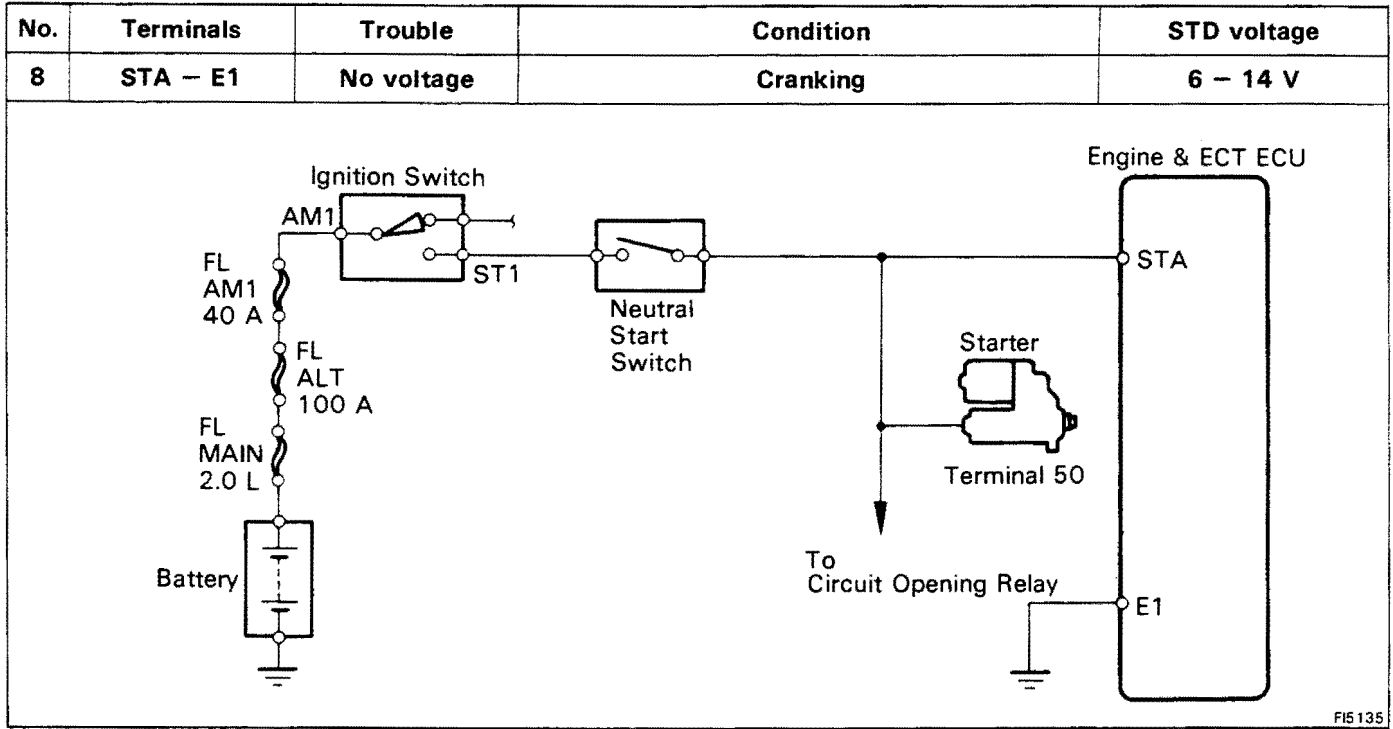

FI5135

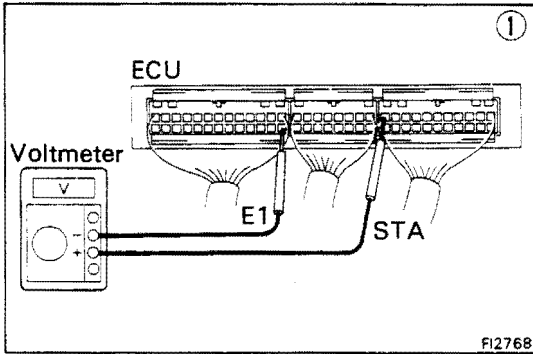

FI2768

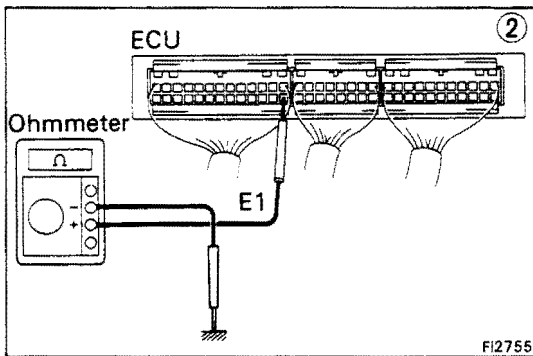

FI2755

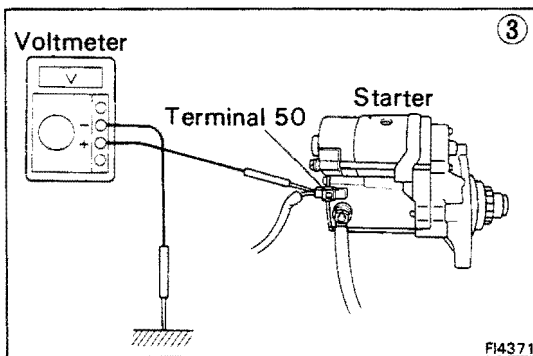

FI4371

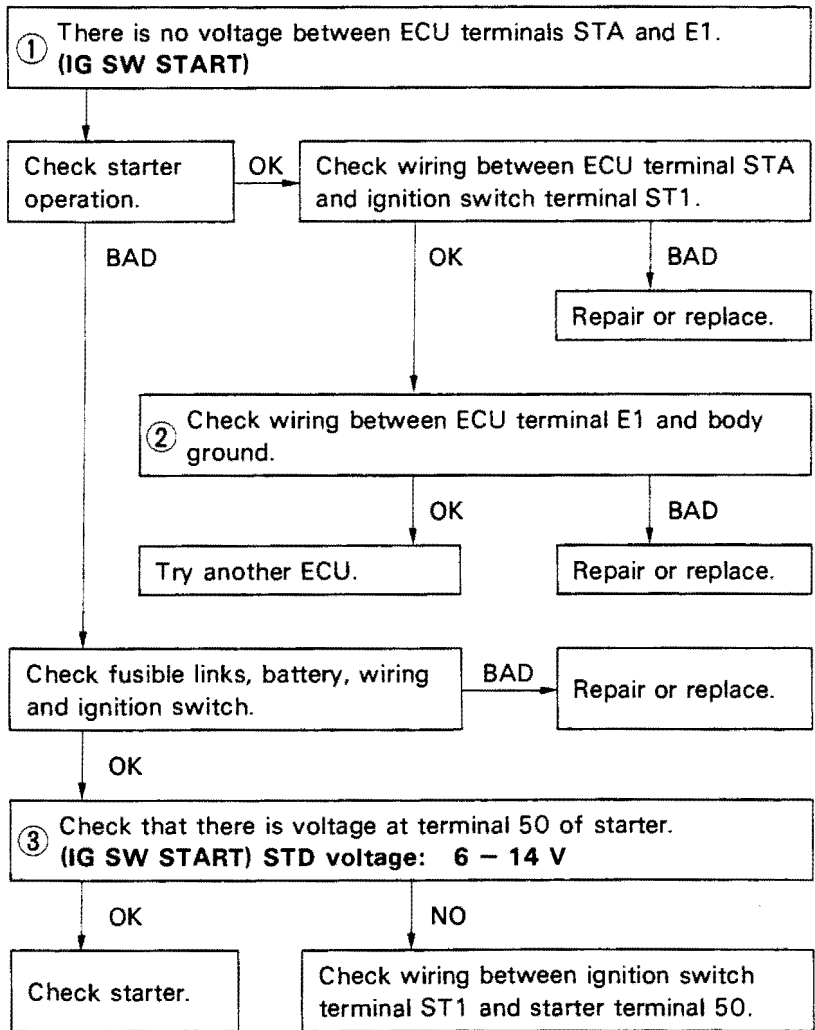

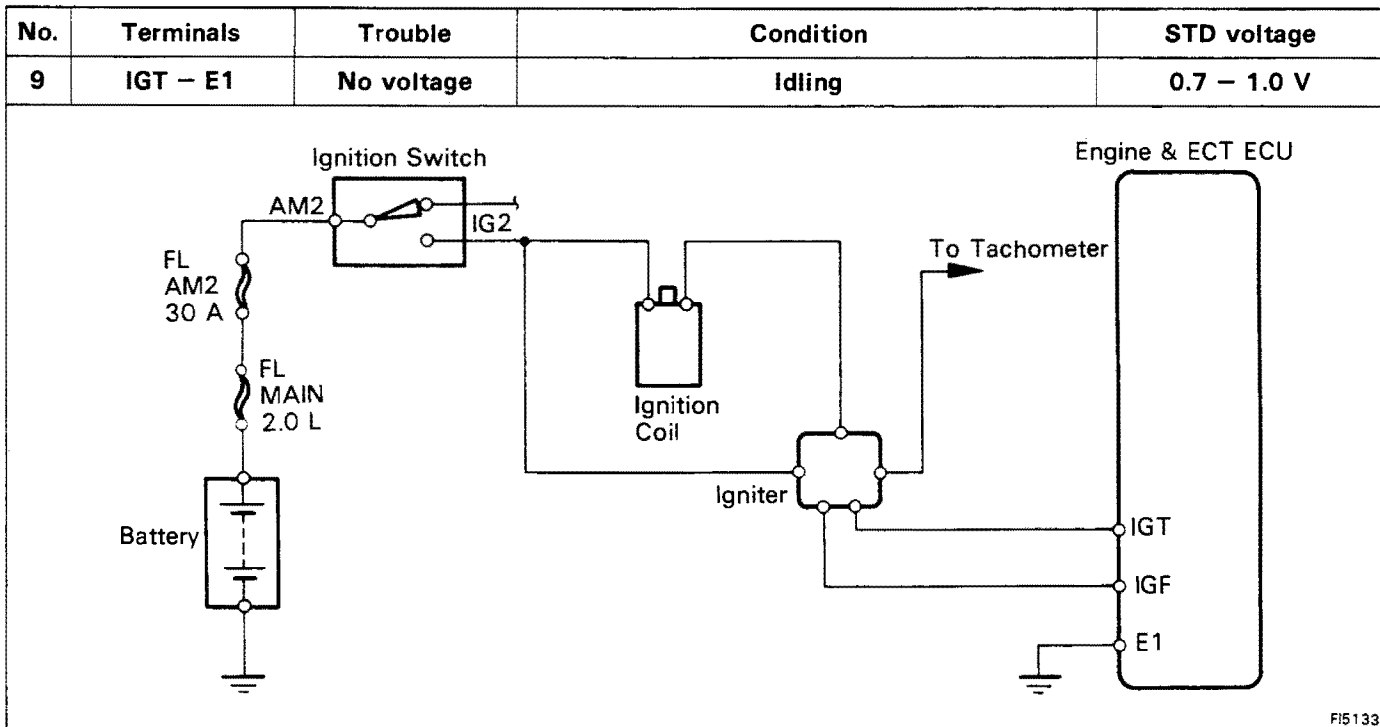

FI5133

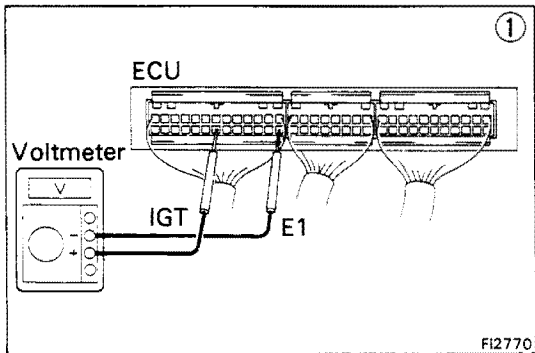

FI2770

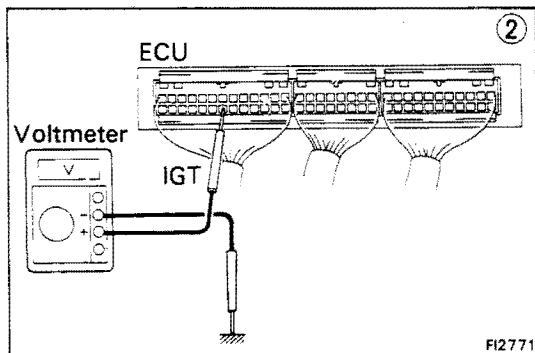

FI2771

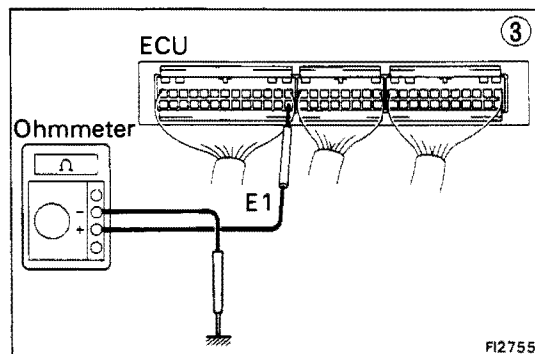

FI2755

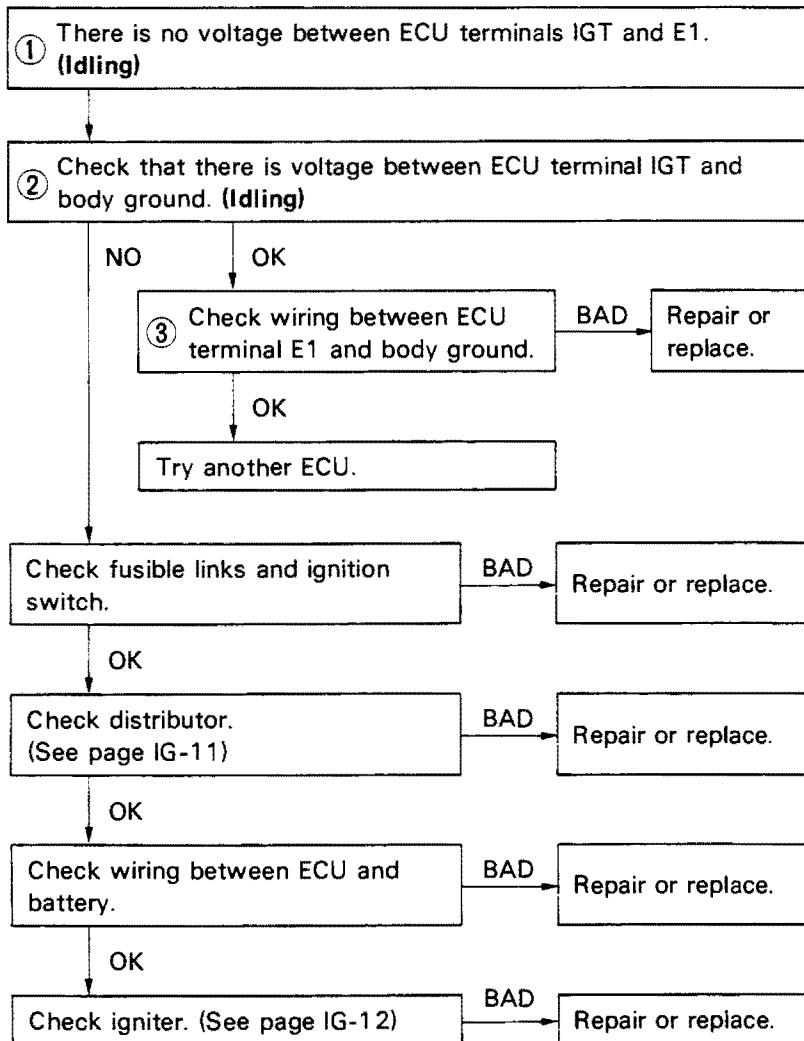

No.	Terminals	Trouble	Condition		STD voltage
10	ISCC – E1 ISCO	No voltage	IG SW ON	Engine and ECT ECU connected disconnected	8 – 14 V

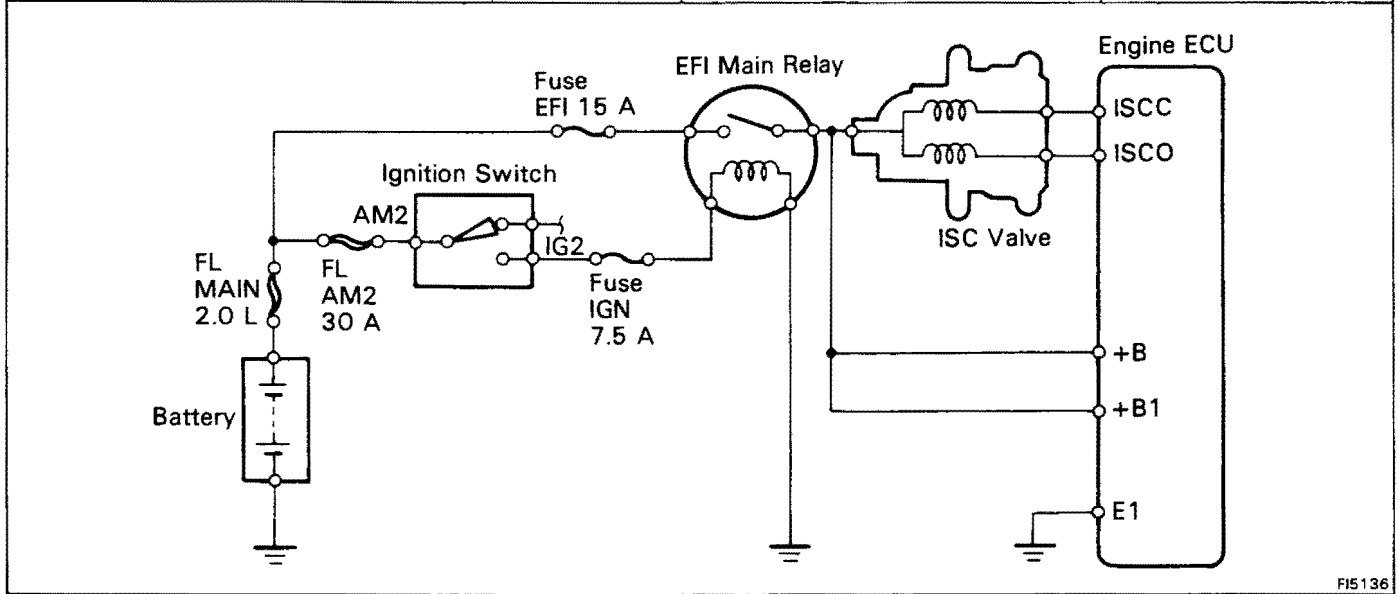

FI5136

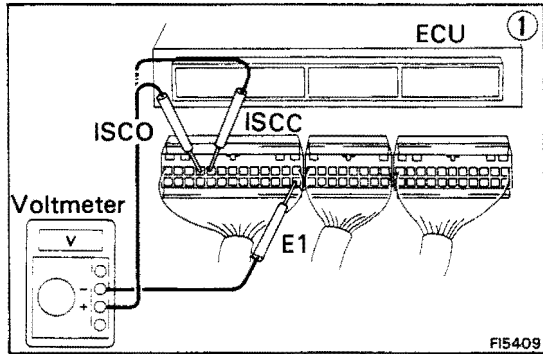

FI5409

① There is no voltage between ECU terminals ISCC or ISCO and E1. (IG SW ON)

② Check that there is voltage between ECU terminal +B or +B1 and body ground. (IG SW ON)

OK

NO

Refer to +B – E1 trouble section (No.1). (See page FI-56)

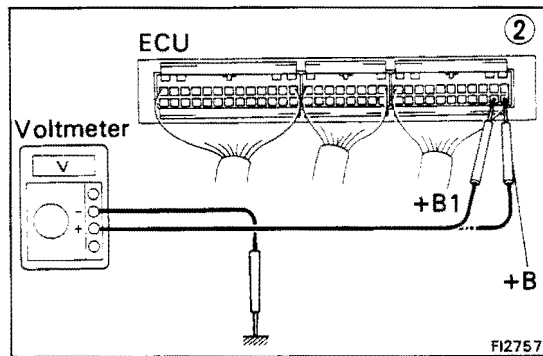

FI2757

③ Check resistance between ISC valve terminals +B and ISCC or ISCO. STD resistance: 19.3 – 22.3 Ω

BAD

Replace ISC valve.

OK

Check wiring between ECU and ISC valve.

BAD

Repair or replace wiring.

OK

Try another ECU.

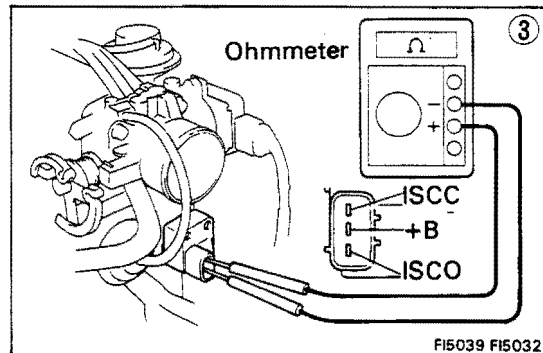

FI5039 FI5032

No.	Terminals	Trouble	Condition	STD voltage
11	W - E1	No voltage	No trouble ("CHECK" engine warning light off) and engine running.	10 - 14 V

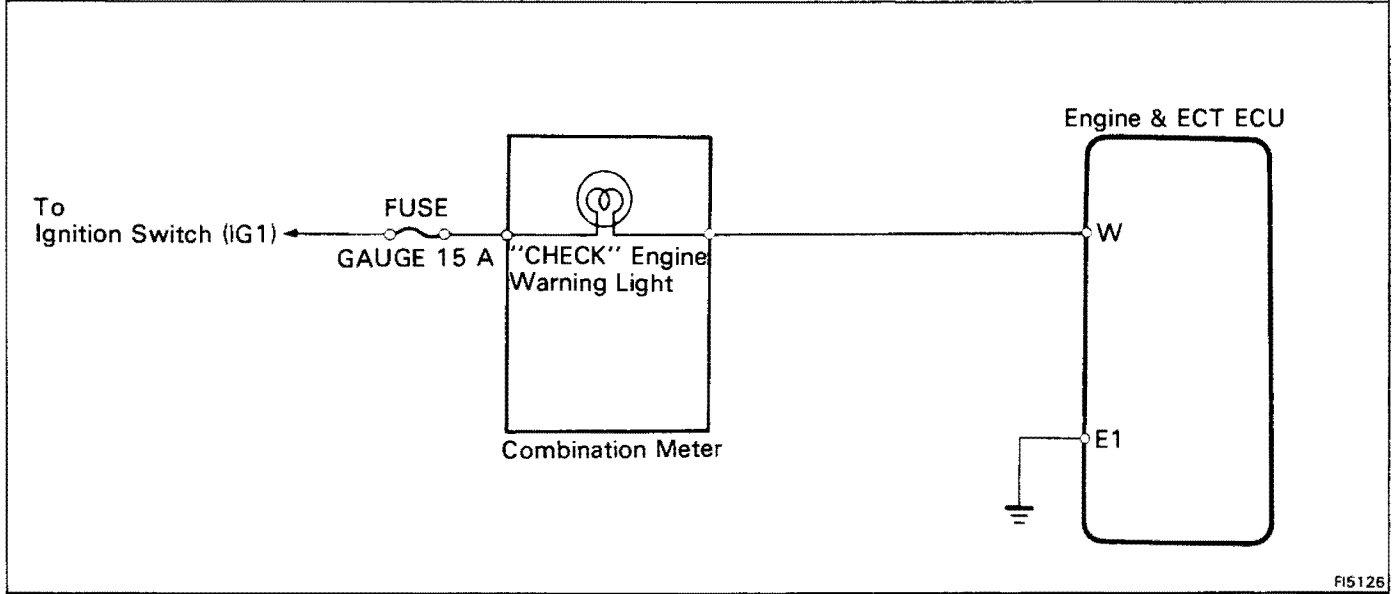

FI5126

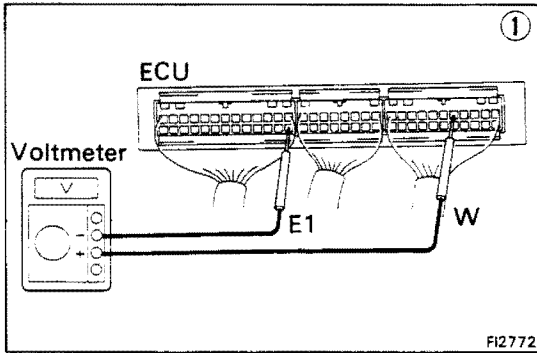

FI2772

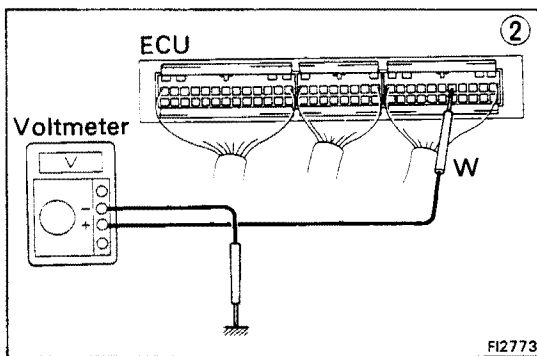

FI2773

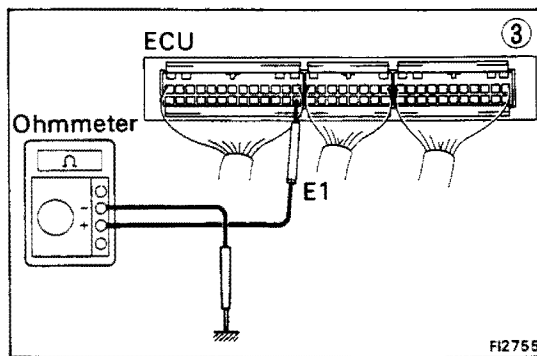

FI2755

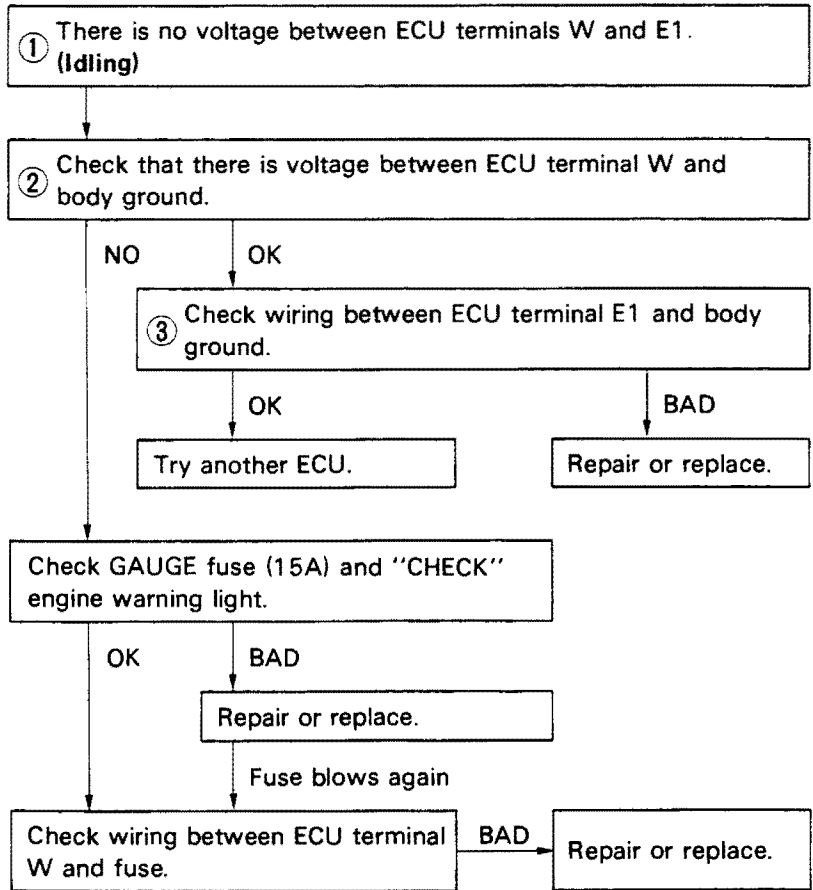

No.	Terminals	Trouble	Condition	STD Voltage
12	A/C — E1	No voltage	Air conditioning ON	8 — 14 V

FI0922

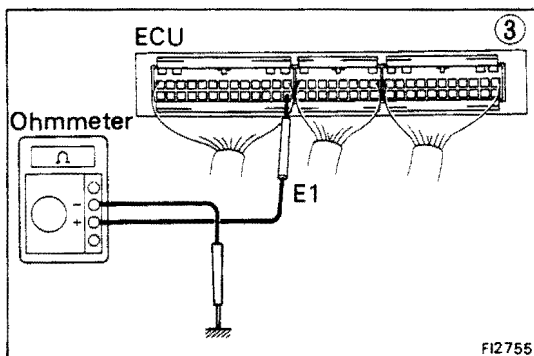
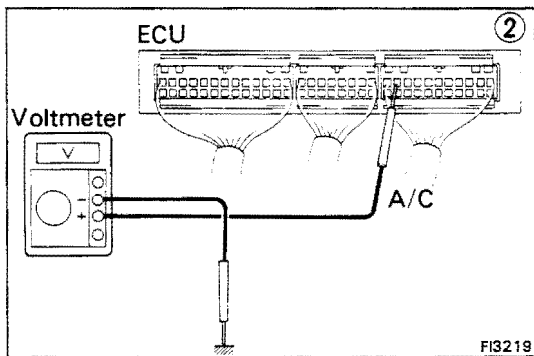
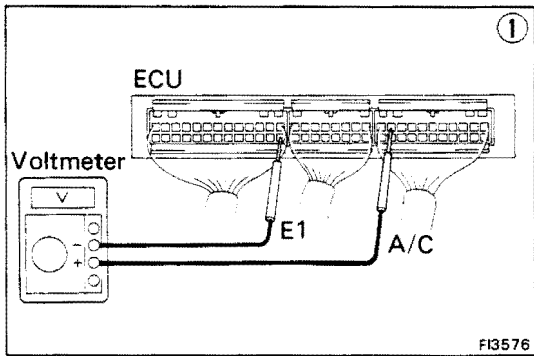

```

    graph TD
      Step1["① There is no voltage between ECU terminals A/C and E1.  
(Air conditioning ON)"] --> Step2["② Check that there is voltage between ECU terminal A/C and  
body ground."]
      Step2 -- NO --> Step3["③ Check wiring between ECU  
terminal E1 and body ground."]
      Step2 -- OK --> Step4["Try another ECU."]
      Step3 -- BAD --> Step3a["Repair or  
replace."]
      Step3 -- OK --> Step4
      Step4 --> Step5["Check compressor running."]
      Step5 -- OK --> Step6["Check wiring between  
ECU terminal A/C and amplifier."]
      Step5 -- BAD --> Step7["Check that there is voltage between  
amplifier terminal and body ground."]
      Step6 -- BAD --> Step7
      Step6 -- OK --> Step8["Check wiring between amplifier  
and ECU or compressor."]
      Step7 -- BAD --> Step7a["Repair or  
replace."]
      Step7 -- OK --> Step8
      Step8 -- BAD --> Step8a["Repair or  
replace."]
      Step8 -- OK --> End[" "]
    
```



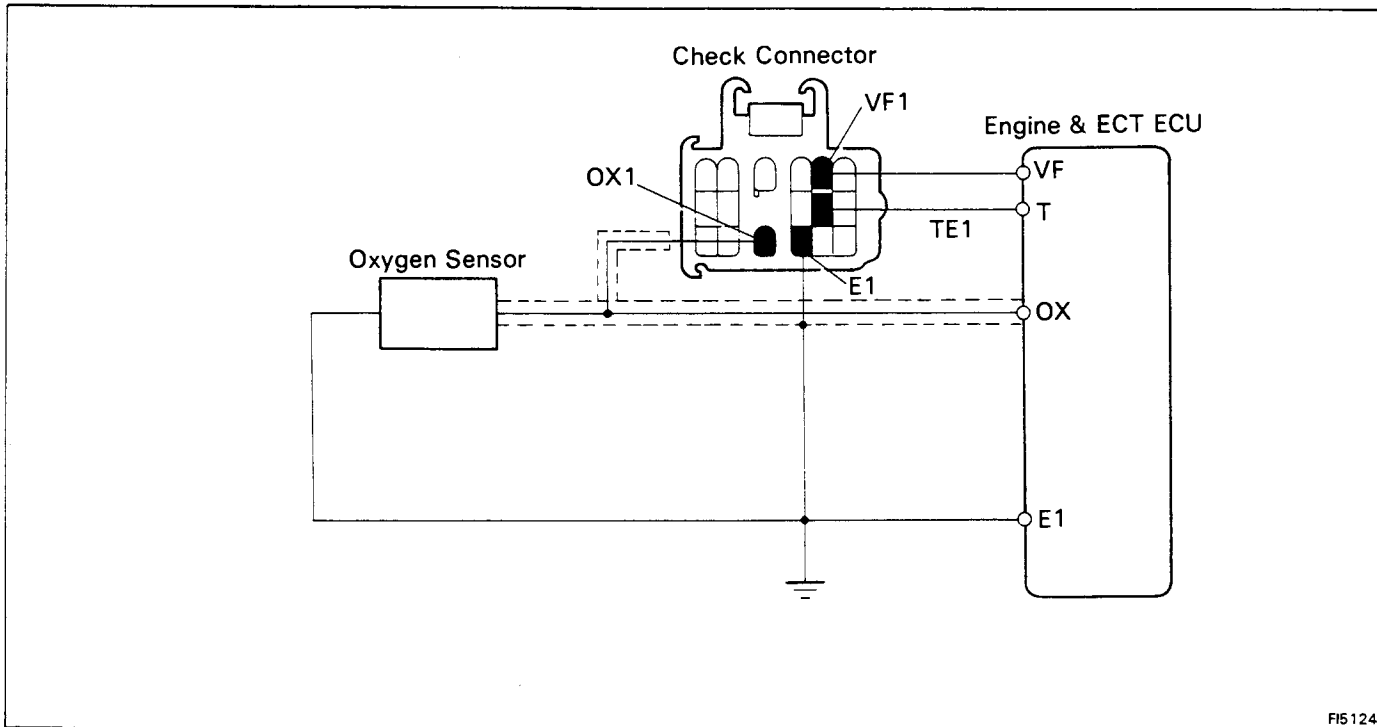

FI5124

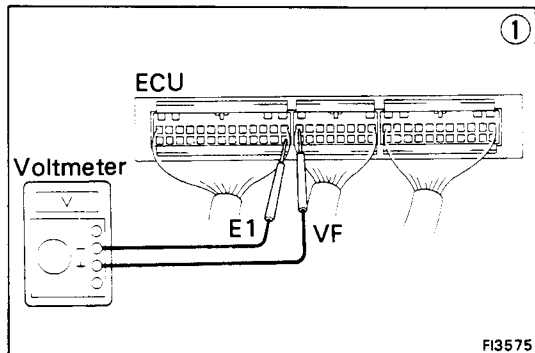

FI3575

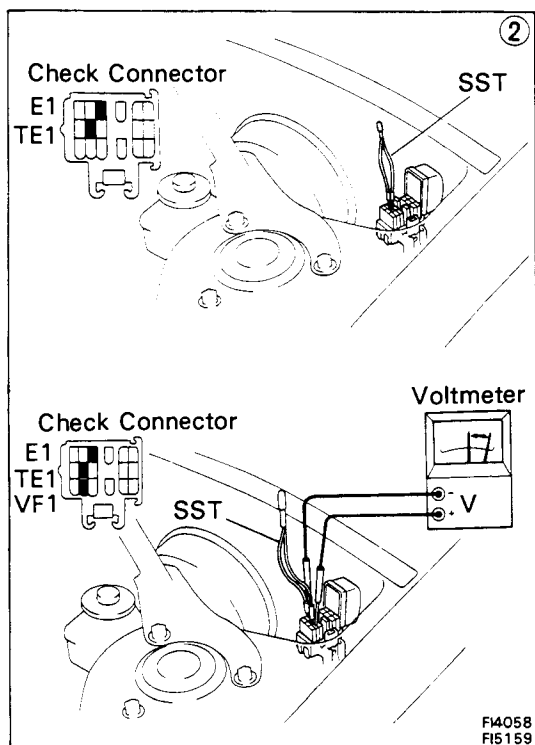

FI4058  
FI5159

```

    graph TD
        A["① There is no voltage between ECU terminals VF and E1."] --> B["Check that there is voltage between ECU terminal VF and body ground."]
        B -- NO --> C["Is air leaking into air induction system?"]
        B -- OK --> D["Check wiring between ECU terminal E1 and body ground."]
        D -- OK --> E["Try another ECU."]
        D -- BAD --> F["Repair or replace."]
        E -- BAD --> F
        C -- BAD --> G["Repair replace."]
        C -- OK --> H["Check spark plugs. (See page IG-7)"]
        H -- BAD --> I["Repair or replace."]
        H -- OK --> J["Check distributor and ignition system. (See page IG-4)"]
        J -- BAD --> I
        J -- OK --> K["Check fuel pressure. (See page FI-103)"]
        K -- BAD --> L["Repair or replace."]
        K -- OK --> M["Check injectors. (See page FI-134)"]
        M -- BAD --> L
        M -- OK --> N["* Check cold start injector. (See page FI-118)"]
        N -- BAD --> I
        N -- OK --> O["Check vacuum sensor. (See page FI-189)"]
        O -- BAD --> I
        O -- OK --> P["② Check operation of oxygen sensor. (See page FI-201)"]
        P -- OK --> Q["System normal."]
        P -- BAD --> R["Check wiring between oxygen sensor and ECU."]
        R -- BAD --> S["Repair wiring."]
        R -- OK --> T["Replace oxygen sensor."]
    
```

\*Rich malfunction only

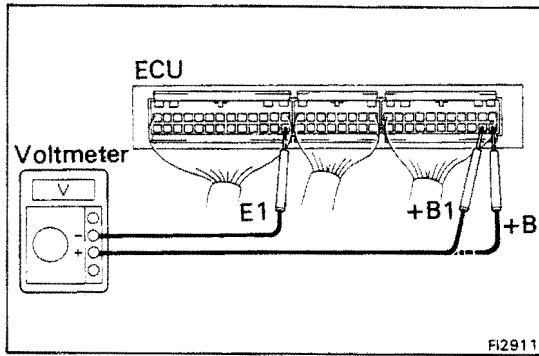

### EFI SYSTEM CHECK PROCEDURE (3S-GE)

**HINT:**

- Perform all voltage measurements with the connectors connected. (ex. Code No.10)
- Verify that the battery voltage is 11 V or more when the ignition switch is in "ON" position.

Using a voltmeter with high impedance (10 kΩ/V minimum), measure the voltage at each terminal of the wiring connectors.

### Terminals of Engine (and ECT) ECU (3S-GE)

Symbol	Terminal name	Symbol	Terminal name	Symbol	Terminal name
E01	POWER GROUND	/	-	*2NSW	NEUTRAL START SWITCH
E02	POWER GROUND	G2	DISTRIBUTOR	AC1	A/C MAGNET SWITCH
No. 1	INJECTOR	G1	DISTRIBUTOR	ACT	A/C AMPLIFIER
No. 3	INJECTOR	NE	DISTRIBUTOR	SP1	SPEED SENSOR (Meter side)
No. 2	INJECTOR	E1	ENGINE GROUND	*2OD1	CRUISE CONTROL ECU
No. 4	INJECTOR	VF	CHECK CONNECTOR	/	-
*1STJ	COLD START INJECTOR	G ⊖	DISTRIBUTOR	L1	TEMS ECU
*2P	PATTERN SELECT SWITCH	/	-	*2OD2	CRUISE CONTROL MAIN SWITCH
/	-	T	CHECK CONNECTOR	L2	TEMS ECU
RSC	ISC VALVE	*1OX1	OXYGEN SENSOR	/	-
RSO	ISC VALVE	*1OX2	CHECK CONNECTOR	L3	TEMS ECU
*1HT	OXYGEN SENSOR HEATER	KNK	KNOCK CONTROL	W	WARNING LIGHT SENSOR
/	-	*3VAF	VARIABLE RESISTOR	/	-
*2S1	ECT SOLENOID	THW	WATER TEMP. SENSOR	STP	STOP LIGHT SWITCH
IGT	IGNITER	IDL	THROTTLE POSITION SENSOR	*2	NEUTRAL START SWITCH
*2S2	ECT SOLENOID	THA	AIR TEM. SENSOR	/	-
*2SL	ECT SOLENOID	VTA	THROTTLE POSITION SENSOR	FC	CIRCUIT OPENING RELAY
FPU	FUEL PRESSURE-UP VSV	PIM	VACUUM SENSOR	ELS	TAILLIGHT and DEFOGGER
ACIS	ACIS VSV	*2L	NEUTRAL START SWITCH VACUUM SENSOR	+B1	MAIN RELAY
*2SP2	SPEED SENSOR (A/T side)	VC	THROTTLE POSITION SENSOR	BATT	BATTERY
*2DG	CHECK CONNECTOR	E2	SENSOR GROUND	+B	MAIN RELAY
IGF	IGNITER	STA	STARTER SWITCH		

Engine (and ECT) ECU Terminals

\*1 w/ TWC  
 \*2 w/ ECT  
 \*3 w/o TWC

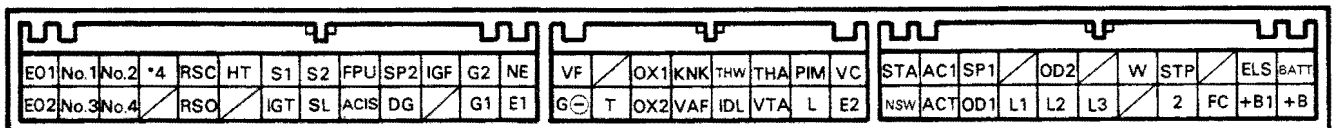

\*4 w/ TWC → STJ  
 w/ ECT → P

### Voltage at Engine (and ECT) ECU Wiring Connectors (3S-GE)

No.	Terminals	Condition		STD voltage (V)	See page
1	+B +B1 — E1	IG SW ON		10 — 14	FI-72
2	BATT — E1	—		10 — 14	FI-73
3	IDL — E2	IG SW ON	Throttle valve open	4 — 6	FI-74
	VC — E2		—	4 — 6	
	VTA — E2		Throttle valve fully closed	0.1 — 1.0	
			Throttle valve open	4 — 5	
4	PIM — E2	IG SW ON		2.5 — 4.5	FI-76
	VC — E2			4 — 6	
5	No.1 No.2 — E01 No.3 — E02 No.4	IG SW ON		10 — 14	FI-77
6	THA — E2	IG SW ON	Intake air temp. 20° (68°F)	1 — 3	FI-78
7	THW — E2		Coolant temp. 80°C (176°F)	0.1 — 1.0	FI-79
8	STA — E1	Cranking		6 — 14	FI-80
9	IGT — E1	Idling		0.7 — 1.0	FI-81
10	RSC — E1 RSO — E1	IG SW ON	Engine (and ECT) ECU connectors disconnected	8 — 14	FI-82
11	W — E1	No trouble ("CHECK" engine warning light off) and engine running		10 — 14	FI-83
12	AC1 — E1	IG SW ON	Air conditioning ON	8 — 14	FI-84

**Engine (and ECT) ECU Terminals**

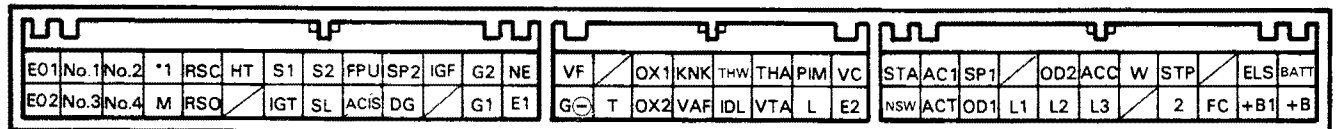

\*1 w/ TWC → STJ  
w/ ECT → P

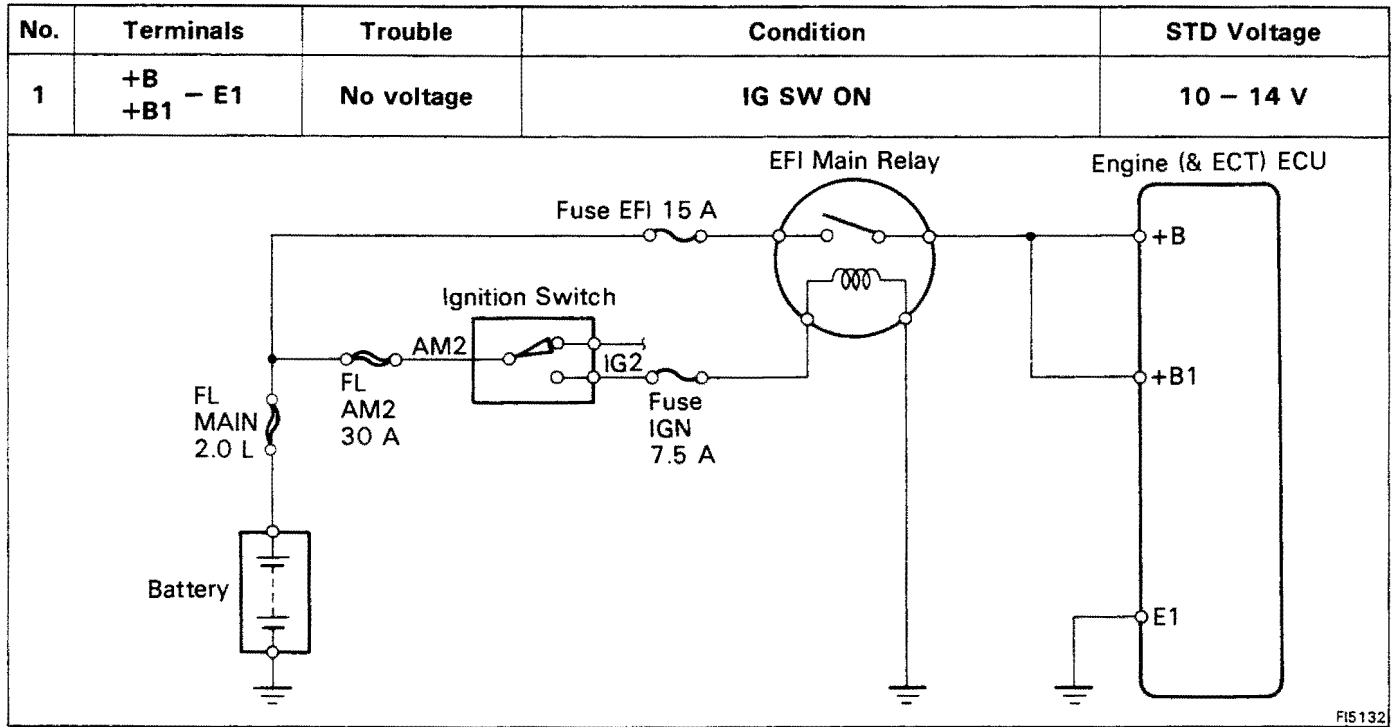

FI5132

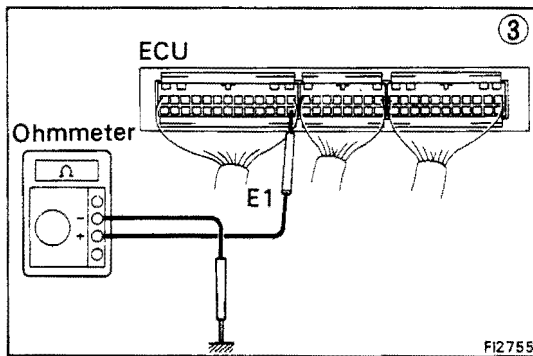
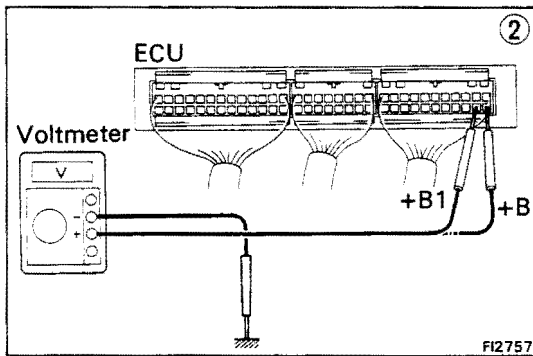
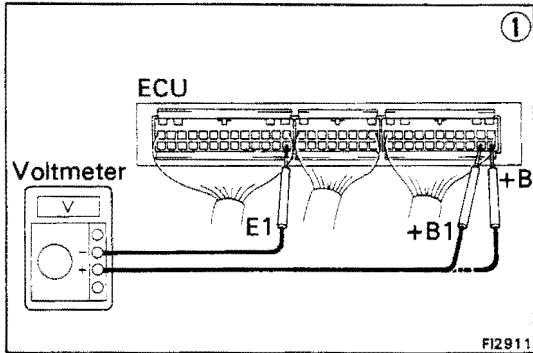

```

    graph TD
      Step1["① There is no voltage between ECU terminals +B or +B1 and E1. (IG SW ON)"]
      Step2["② Check that there is voltage between ECU terminal +B or +B1 and body ground. (IG SW ON)"]
      Step3["③ Check wiring between ECU terminal E1 and body ground."]
      CheckFuses["Check fuses, fusible links and ignition switch."]
      CheckRelay["Check EFI main relay. (See page FI-182)"]
      CheckWiring["Check wiring between EFI main relay and battery."]
      TryECU["Try another ECU."]
      RepairECU["Repair or replace."]
      RepairFuses["Repair or replace."]
      ReplaceRelay["Replace."]
      RepairWiring["Repair or replace."]

      Step1 --> Step2
      Step2 -- NO --> CheckFuses
      Step2 -- OK --> Step3
      Step3 -- OK --> TryECU
      Step3 -- BAD --> RepairECU
      CheckFuses -- BAD --> RepairFuses
      CheckFuses -- OK --> CheckRelay
      CheckRelay -- BAD --> ReplaceRelay
      CheckRelay -- OK --> CheckWiring
      CheckWiring -- BAD --> RepairWiring
      CheckWiring -- OK --> End
  
```

No.	Terminals	Trouble	Condition	STD Voltage
2	BATT — E1	No voltage	—	10 — 14 V

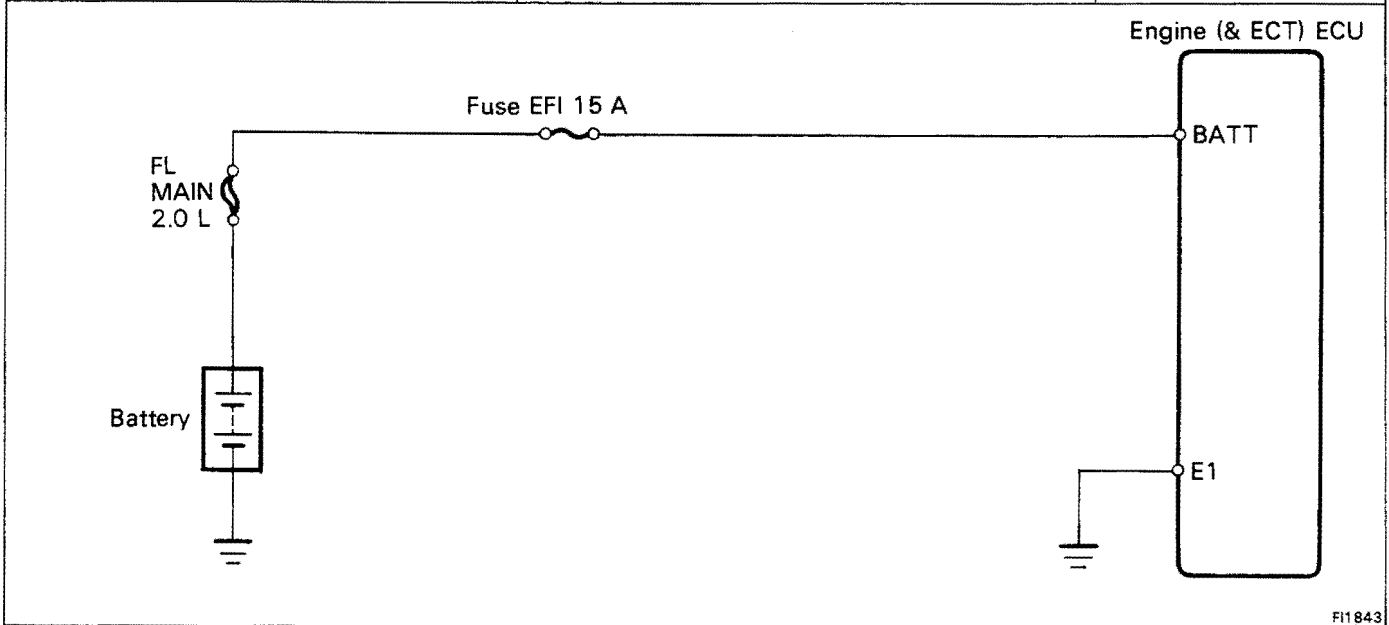

FI1843

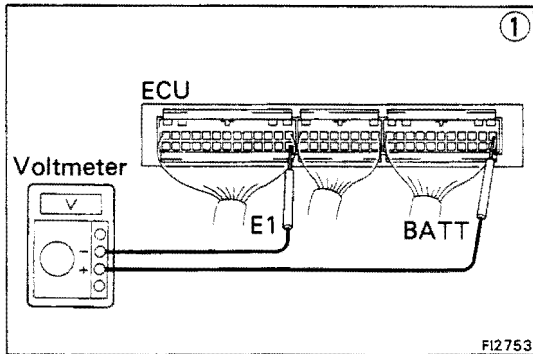

FI2753

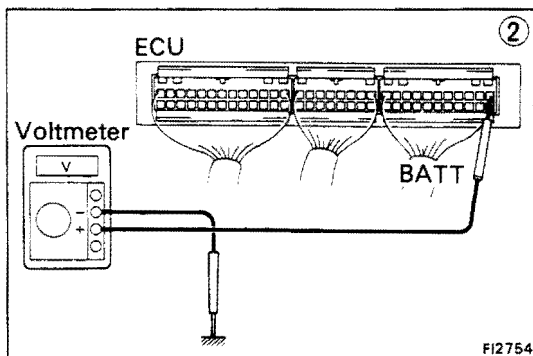

FI2754

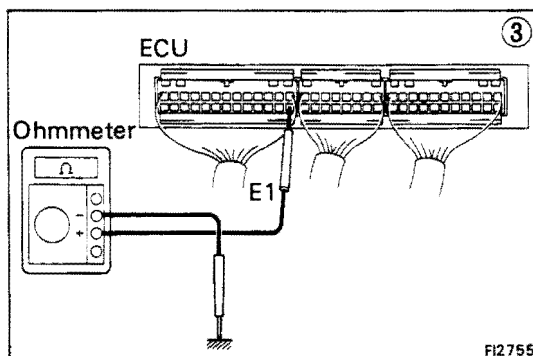

FI2755

```

    graph TD
      Step1["① There is no voltage between ECU terminals BATT and E1."] --> Step2["② Check that there is voltage between ECU terminal BATT and body ground."]
      Step2 -- NO --> Fuse["Check fuse and fusible link."]
      Step2 -- OK --> Step3["③ Check wiring between ECU terminal E1 and body ground."]
      Fuse -- BAD --> FuseReplace["Replace."]
      Fuse -- OK --> Step3
      Step3 -- OK --> ECU["Try another ECU."]
      Step3 -- BAD --> ECUReplace["Repair or replace."]
      Step4["Check wiring between ECU terminal and battery."] -- BAD --> ECUReplace
      Step4 -- OK --> End[" "]
  
```

No.	Terminals	Trouble	Condition	STD Voltage	
3	IDL - E2	No voltage	Ignition switch ON	Throttle valve open	4 - 6 V
	VC - E2			-	4 - 6 V
	VTA - E2			Throttle valve fully closed	0.1 - 1.0 V
				Throttle valve fully open	4 - 5 V

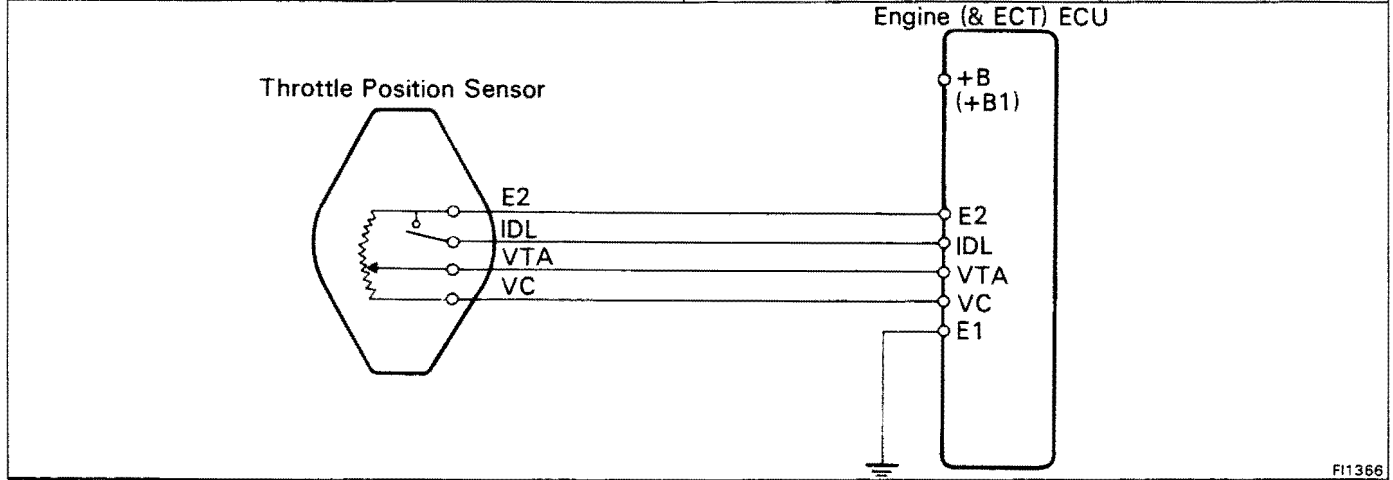

FI1366

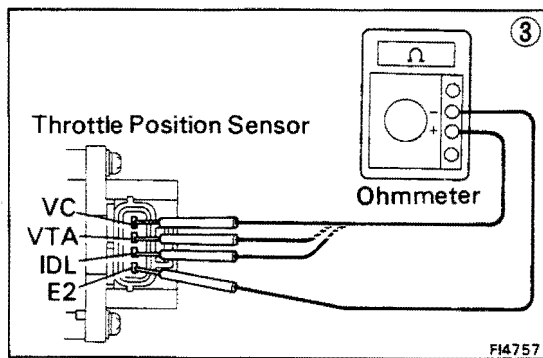
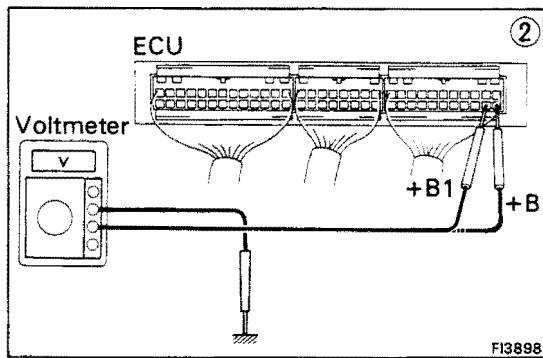
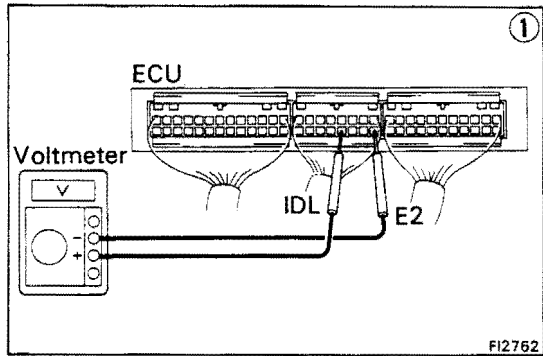

• IDL - E2

```

    graph TD
      A["① There is no voltage between ECU terminals IDL and E2.  
(IG SW ON) (Throttle valve open)"] --> B["② Check that there is voltage between ECU terminal +B (+B1)  
and body ground. (IG SW ON)"]
      B -- NO --> C["Refer to +B - E1 trouble section (No.1).  
(See page FI-72)"]
      B -- OK --> D["Check wiring between ECU terminal E1 and body ground."]
      D -- OK --> E["Try another ECU."]
      D -- BAD --> F["Repair or replace."]
      C --> F
      C -- BAD --> F
      G["③ Check throttle position sensor. (See page FI-165)"] --> H["Repair or replace throttle position sensor."]
      G --> I["Check wiring between ECU and throttle position sensor."]
      I -- OK --> J["Try another ECU."]
      I -- BAD --> F
      F --> K["Repair or replace."]
  
```

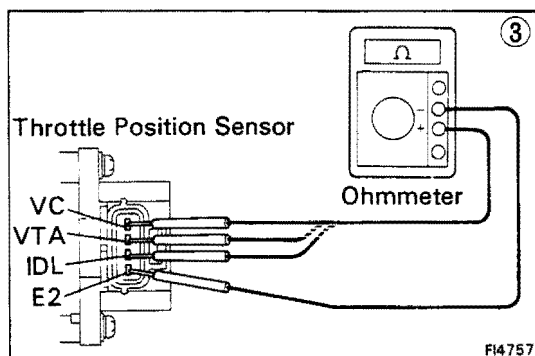
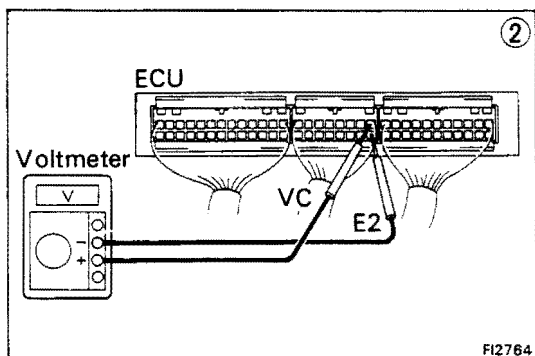
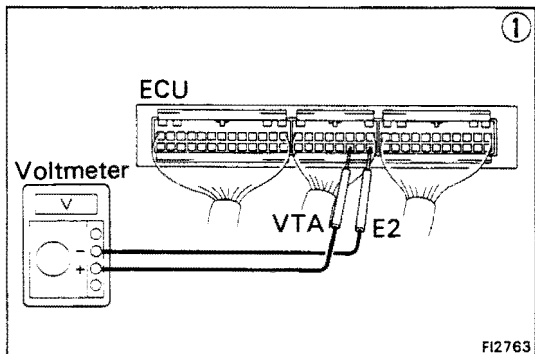
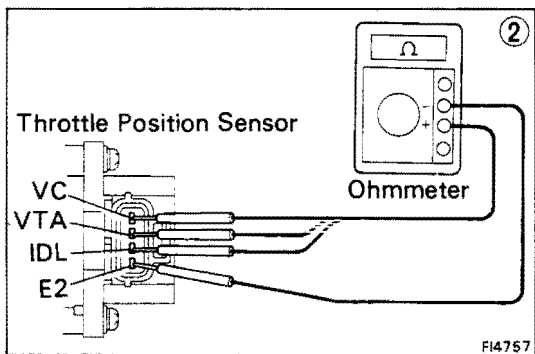
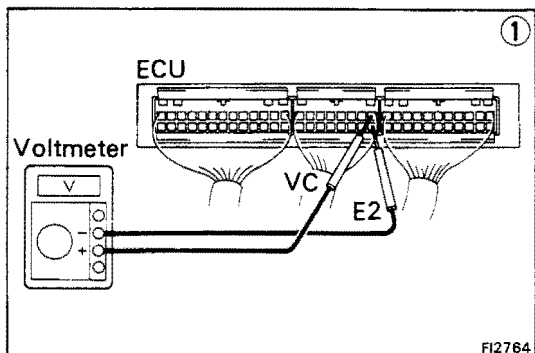

• VC – E2

```

    graph TD
      A["① No voltage between ECU terminals VC and E2.  
(IG SW ON)"] --> B["Check that there is voltage between ECU terminal +B or +B1  
and body ground. (IG SW ON)"]
      B -- OK --> C["② Check throttle position sensor.  
(See page FI-165)"]
      B -- NO --> D["Refer to +B – E1 trouble  
section (No.1).  
(See page FI-72)"]
      C -- BAD --> E["Repair or replace."]
      C -- OK --> F["Check wiring between ECU and throttle  
position sensor."]
      F -- OK --> G["Try another ECU."]
      F -- BAD --> H["Repair or replace."]
    
```

• VTA – E2

```

    graph TD
      A["① No specified voltage at ECU terminals VTA and E2.  
(IG SW ON)"] --> B["② Check that there is voltage between ECU terminals VC and E2.  
(IG SW ON)"]
      B -- NO --> C["Refer to VC – E2  
trouble section."]
      B -- OK --> D["③ Check throttle position sensor.  
(See page FI-165)"]
      D -- BAD --> E["Repair or replace."]
      D -- OK --> F["Check wiring between ECU and  
throttle position sensor."]
      F -- BAD --> G["Repair or replace."]
      F -- OK --> H["Try another ECU."]
    
```

No.	Terminals	Trouble	Condition	STD voltage
4	PIM — E2	No voltage	IG SW ON	2.5 — 4.5 V
	VC — E2			4 — 6 V

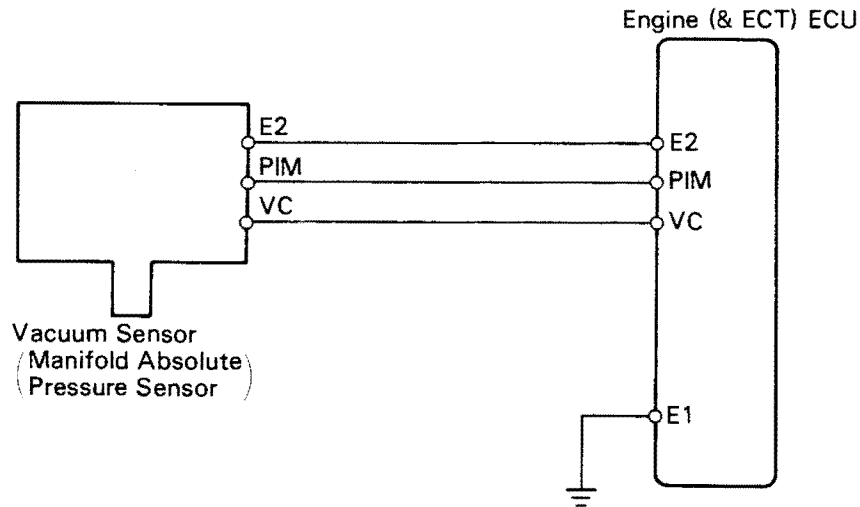

FI1226

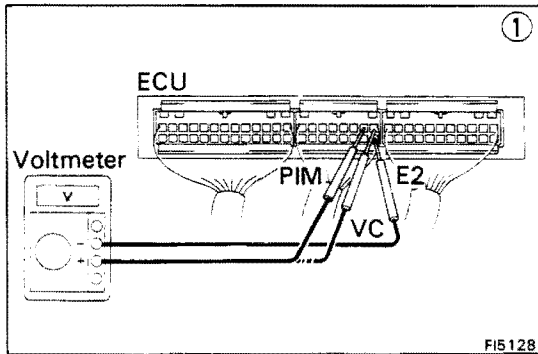

① There is no voltage between ECU terminals PIM or VC and E2. (IG SW ON)

② Check that there is voltage between ECU terminal +B or +B1 and body ground. (IG SW ON)

OK

NO

Refer to +B — E1 trouble section (No.1). (See page FI-72)

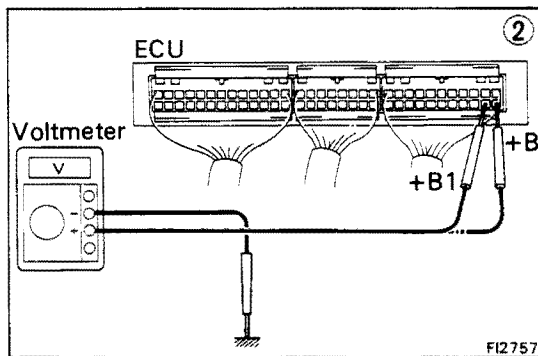

③ Check wiring between ECU terminal E1 and body ground.

OK

BAD

Check vacuum sensor. (See page FI-189)

Repair or replace.

BAD

OK

Replace vacuum sensor.

Check wiring between ECU and vacuum sensor.

OK

BAD

Try another ECU.

Repair or replace.

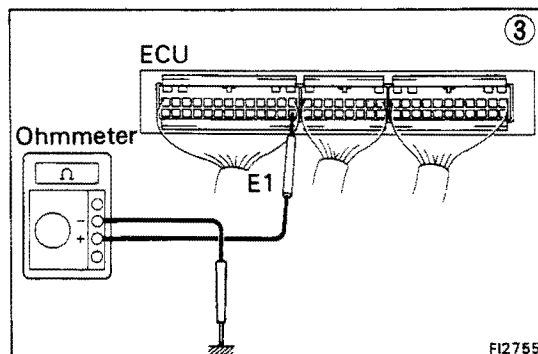



No.	Terminals	Trouble	Condition	STD voltage
5	No.1 No.2 — E01 No.3 — E02 No.4	No voltage	IG SW ON	10 — 14 V

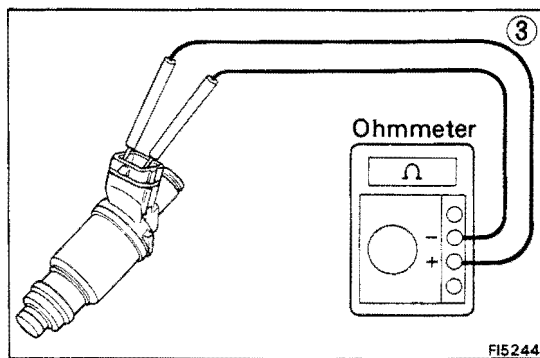
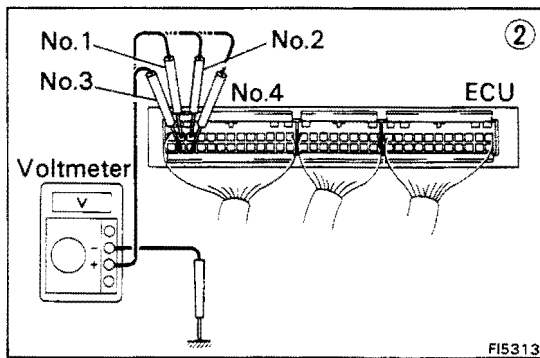
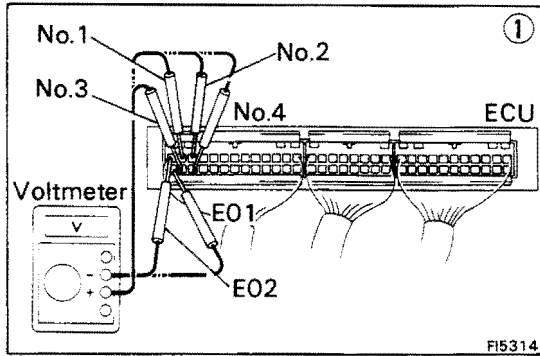
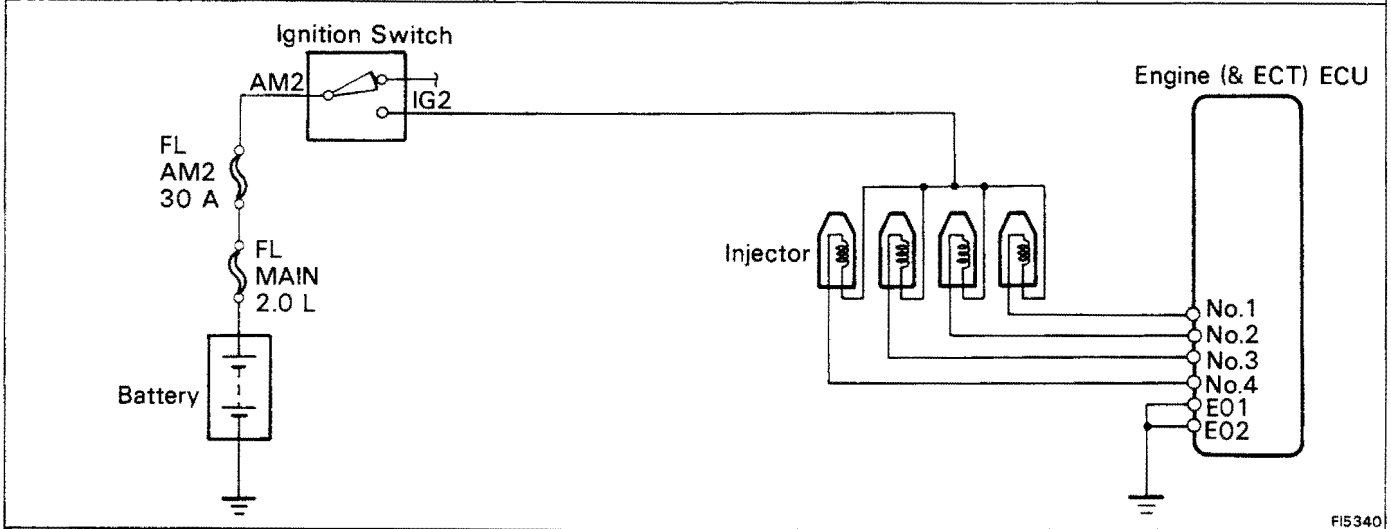

```

    graph TD
      Step1["① There is no voltage between ECU terminals No.1, No.2, No.3 and/or No.4 and E01 and/or E02. (IG SW ON)"]
      Step2["② Check that there is voltage between ECU terminals No.1, No.2, No.3 and/or No.4 and body ground."]
      Step3["③ Check resistance of each injector. STD resistance: Approx 13.8 Ω"]
      
      Step1 --> Step2
      Step2 -- NO --> CheckFuses["Check fusible links and ignition switch."]
      Step2 -- OK --> CheckWiring["Check wiring between ECU terminal E01 and/or E02 and body ground."]
      CheckFuses -- BAD --> RepairFuses["Repair or replace."]
      CheckFuses -- OK --> CheckWiring
      CheckWiring -- OK --> Step3
      CheckWiring -- BAD --> RepairWiring["Repair or replace."]
      Step3 -- BAD --> ReplaceInjector["Replace injector."]
  
```

No.	Terminals	Trouble	Condition		STD voltage
6	THA - E2	No voltage	IG SW ON	Intake air temperature 20°C (68°F)	1 - 3 V

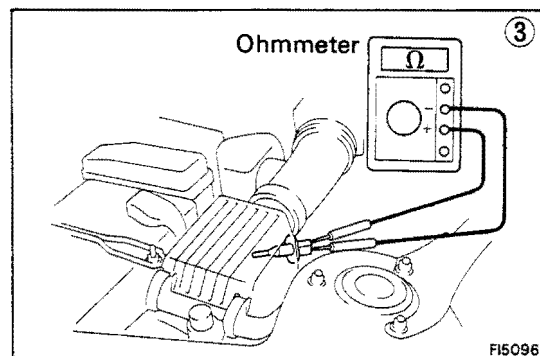
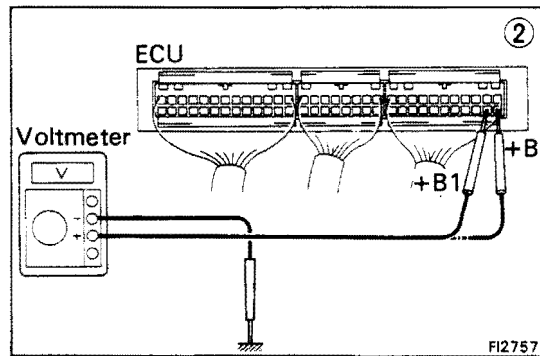
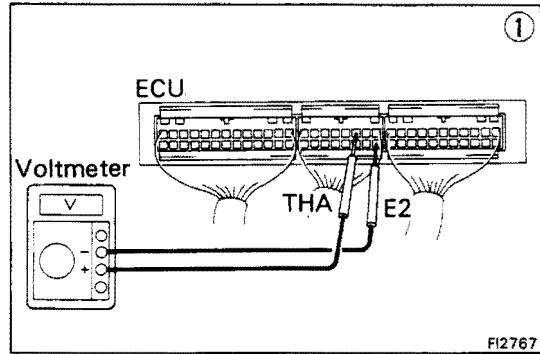
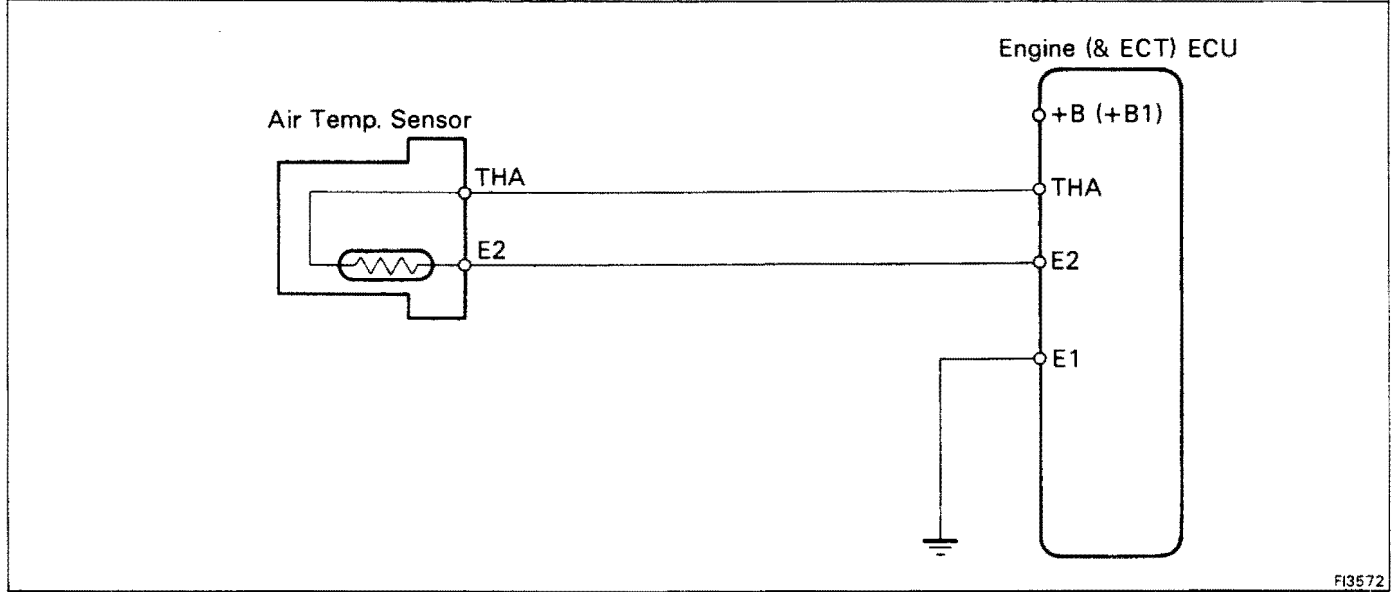

```

    graph TD
      Step1["① There is no voltage between ECU terminals THA and E2.  
(IG SW ON)"] --> Step2["② Check that there is voltage between ECU terminal +B or +B1  
and body ground. (IG SW ON)"]
      Step2 -- OK --> Step3["③ Check air temp. sensor.  
(See page FI-188)"]
      Step2 -- NO --> Ref["Refer to +B1 - E1  
trouble section No.1.  
(See page FI-72)"]
      Step3 -- BAD --> Repair1["Repair air temp.  
sensor."]
      Step3 -- OK --> Step4["Check wiring between ECU and air  
temp. sensor."]
      Step4 -- OK --> TryECU["Try another ECU."]
      Step4 -- BAD --> Repair2["Repair or replace."]
      Step5["Check wiring between ECU terminal E1 and body  
ground."] -- BAD --> Repair3["Repair or replace."]
      Step5 -- OK --> Step3
  
```

No.	Terminals	Trouble	Condition		STD voltage
7	THW - E2	No voltage	IG SW ON	Coolant temperature 80°C (176°F)	0.1 - 1.0 V

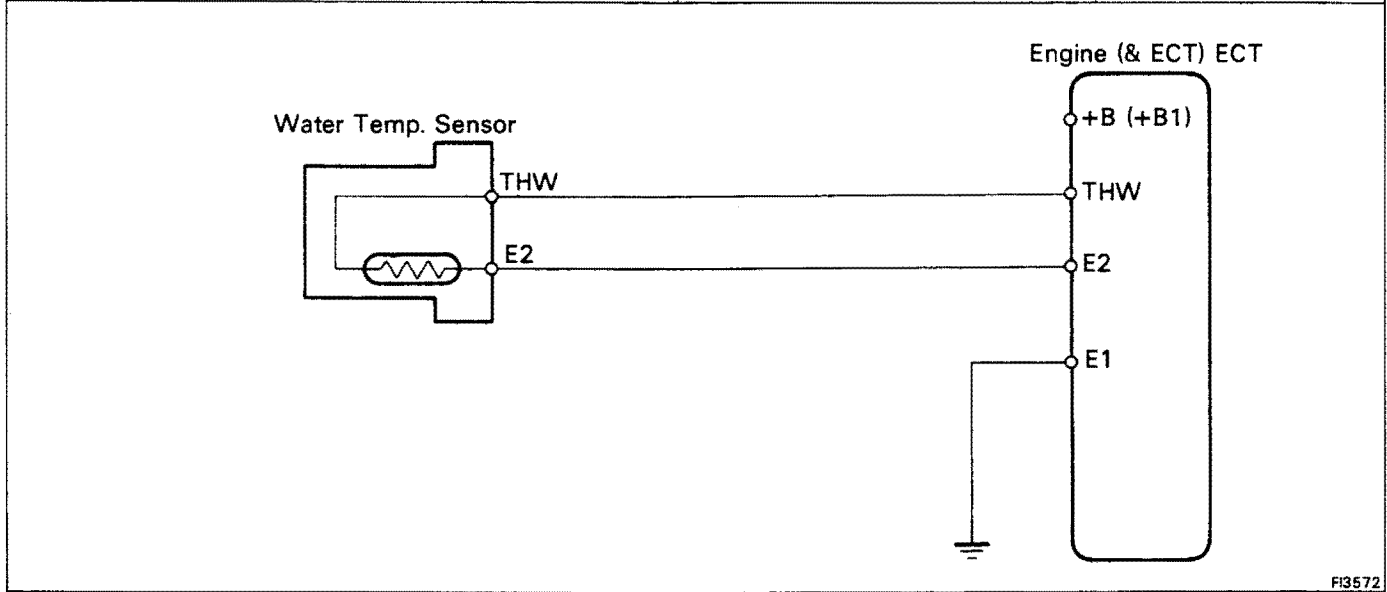

FI3572

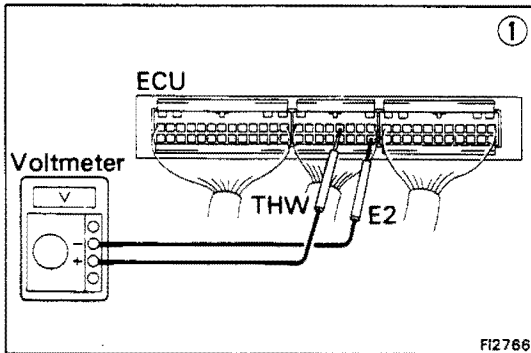

FI2766

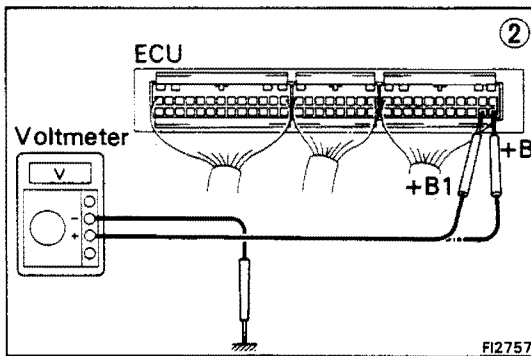

FI2757

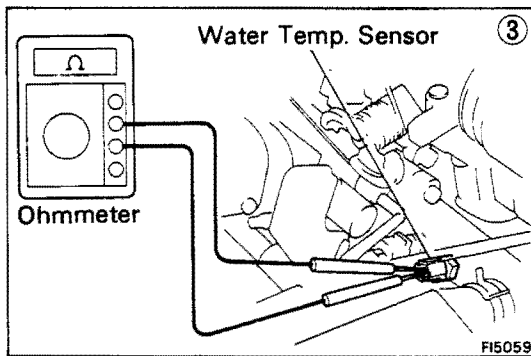

FI5059

```

    graph TD
        Step1["① There is no voltage between ECU terminals THW and E2.  
(IG SW ON)"] --> Step2["② Check that there is voltage between ECU terminal +B (+B1)  
and body ground. (IG SW ON)"]
        Step2 -- OK --> Step3["③ Check water temp. sensor.  
(See page FI-186)"]
        Step2 -- NO --> Refer["Refer to +B - E1  
trouble section (No.1).  
(See page FI-72)"]
        Step3 -- BAD --> ReplaceSensor["Replace water  
temp. sensor."]
        Step3 -- OK --> CheckWiring["Check wiring between ECU and water  
temp. sensor."]
        CheckWiring -- OK --> TryECU["Try another ECU."]
        CheckWiring -- BAD --> Repair["Repair or replace."]
        
        Step2 --> CheckE1["Check wiring between ECU terminal E1 and body ground."]
        CheckE1 -- OK --> Step3
        CheckE1 -- BAD --> Repair
    
```

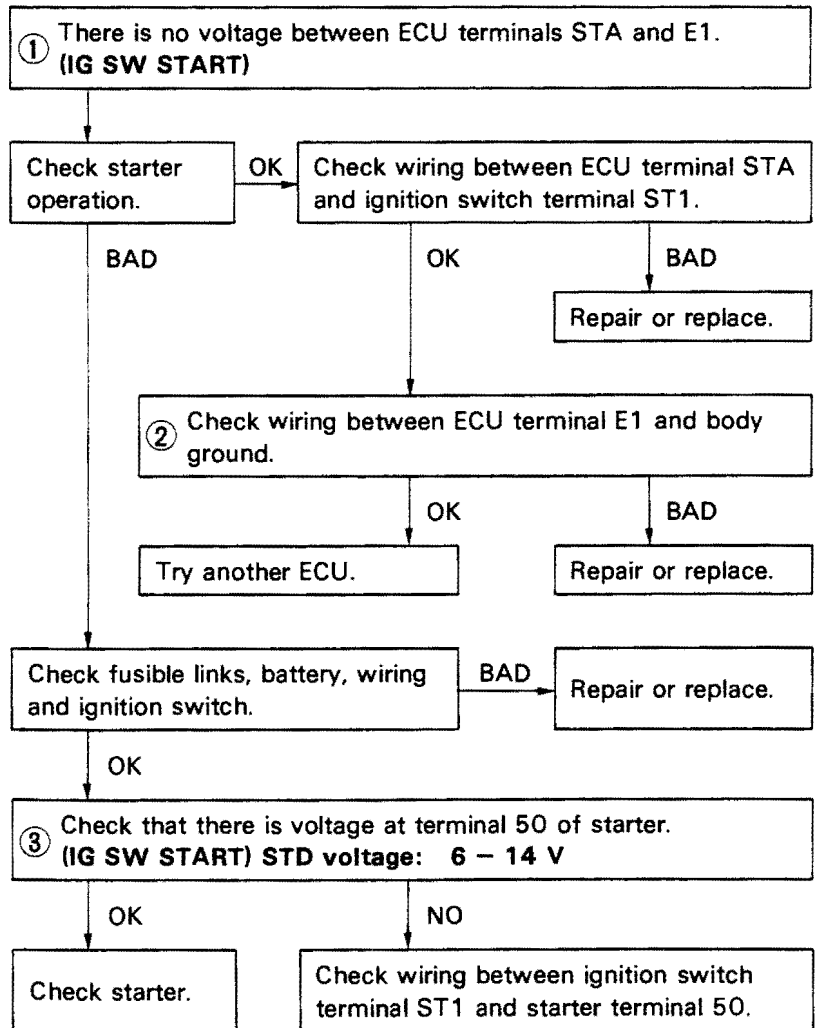
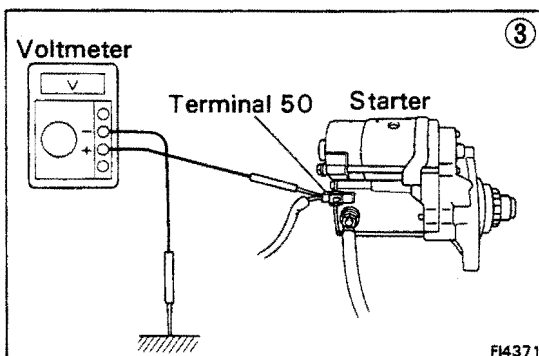
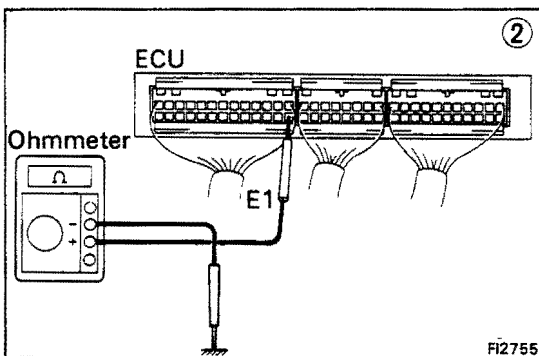
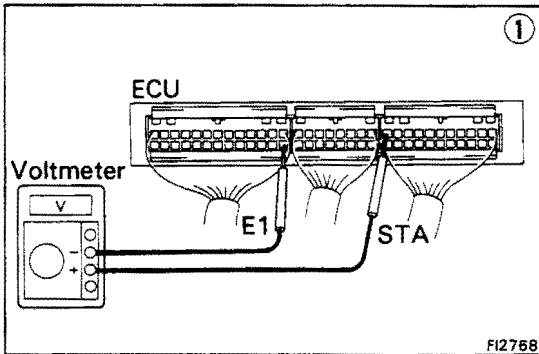
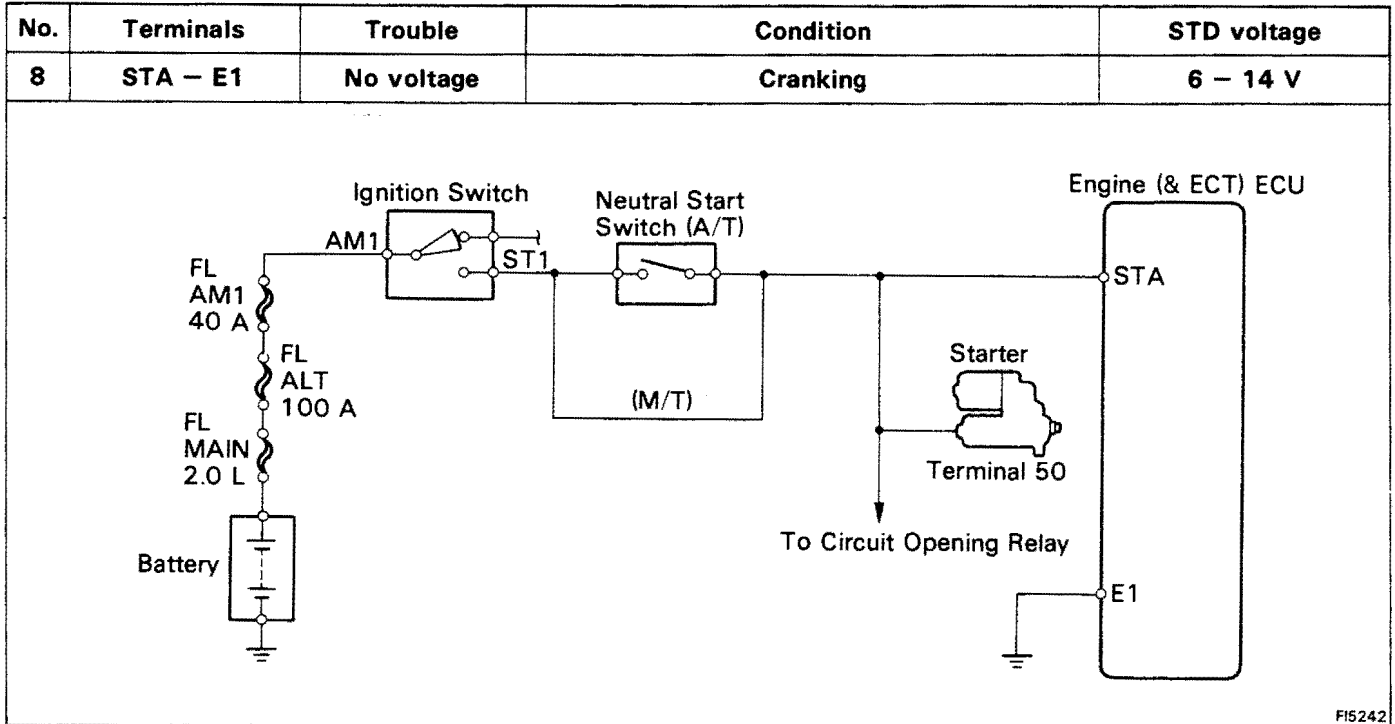

No.	Terminals	Trouble	Condition	STD voltage
9	IGT - E1	No voltage	Idling	0.7 - 1.0 V

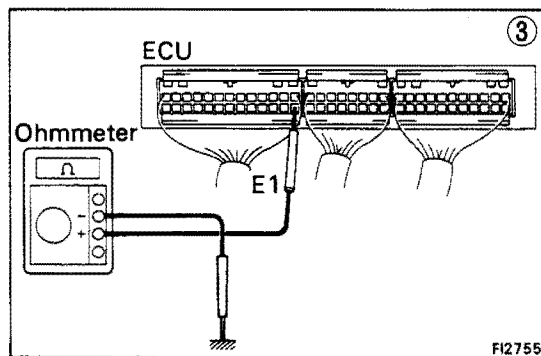
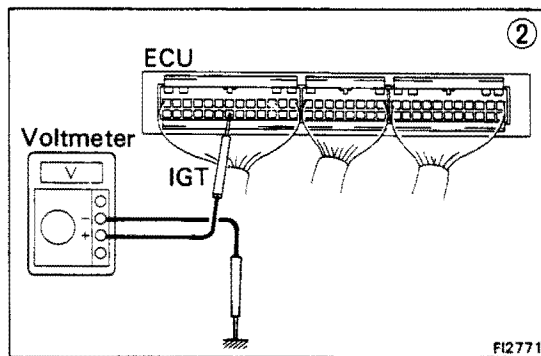
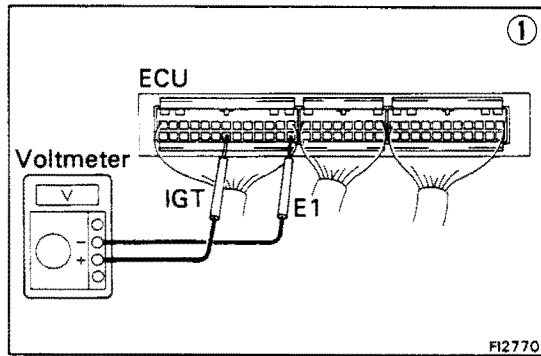
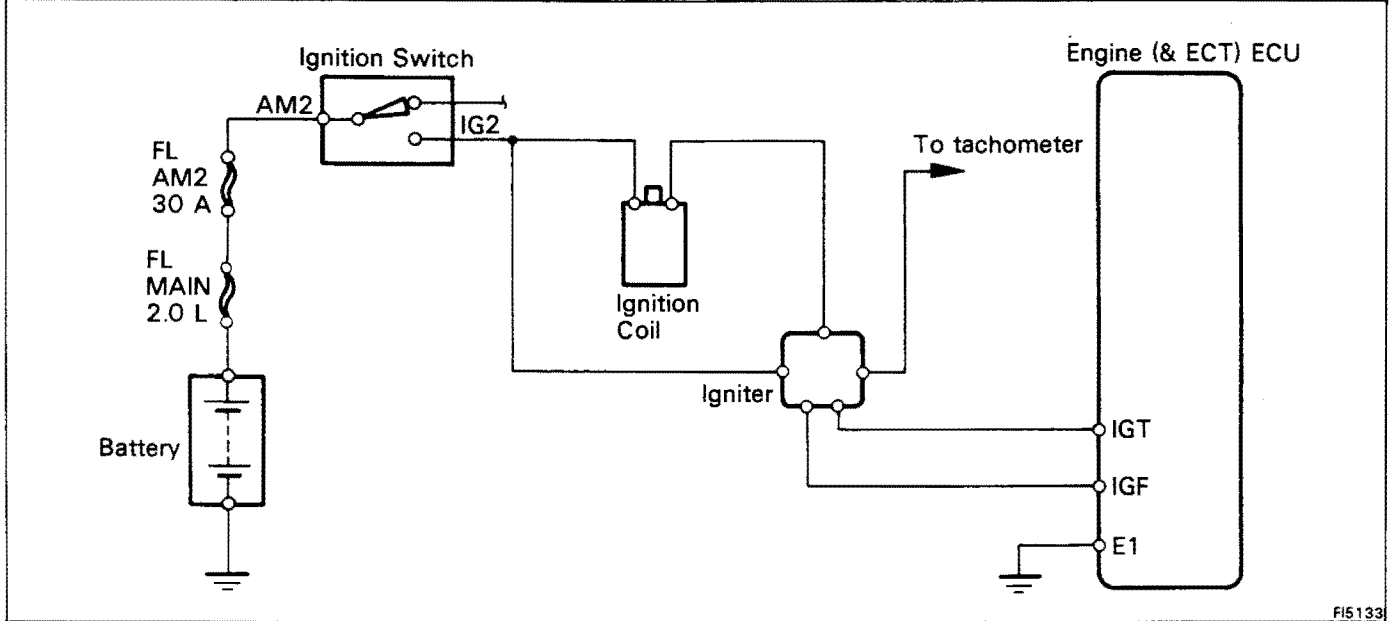

```

    graph TD
      Step1["① There is no voltage between ECU terminals IGT and E1. (Idling)"]
      Step2["② Check that there is voltage between ECU terminal IGT and body ground. (Idling)"]
      Step3["③ Check wiring between ECU terminal E1 and body ground."]
      Step4["Check fusible links and ignition switch."]
      Step5["Check distributor. (See page IG-11)"]
      Step6["Check wiring between ECU and battery."]
      Step7["Check igniter. (See page IG-12)"]
      Step8["Repair or replace."]
      Step9["Try another ECU."]

      Step1 --> Step2
      Step2 -- NO --> Step4
      Step2 -- OK --> Step3
      Step3 -- BAD --> Step8
      Step3 -- OK --> Step9
      Step4 -- BAD --> Step8
      Step4 -- OK --> Step5
      Step5 -- BAD --> Step8
      Step5 -- OK --> Step6
      Step6 -- BAD --> Step8
      Step6 -- OK --> Step7
      Step7 -- BAD --> Step8
      Step7 -- OK --> End[" "]
  
```

No.	Terminals	Trouble	Condition		STD voltage
			IG SW ON	Engine (and ECT) ECU connectors disconnected	
10	RSC RSO — E1	No voltage	IG SW ON	Engine (and ECT) ECU connectors disconnected	8 – 14 V

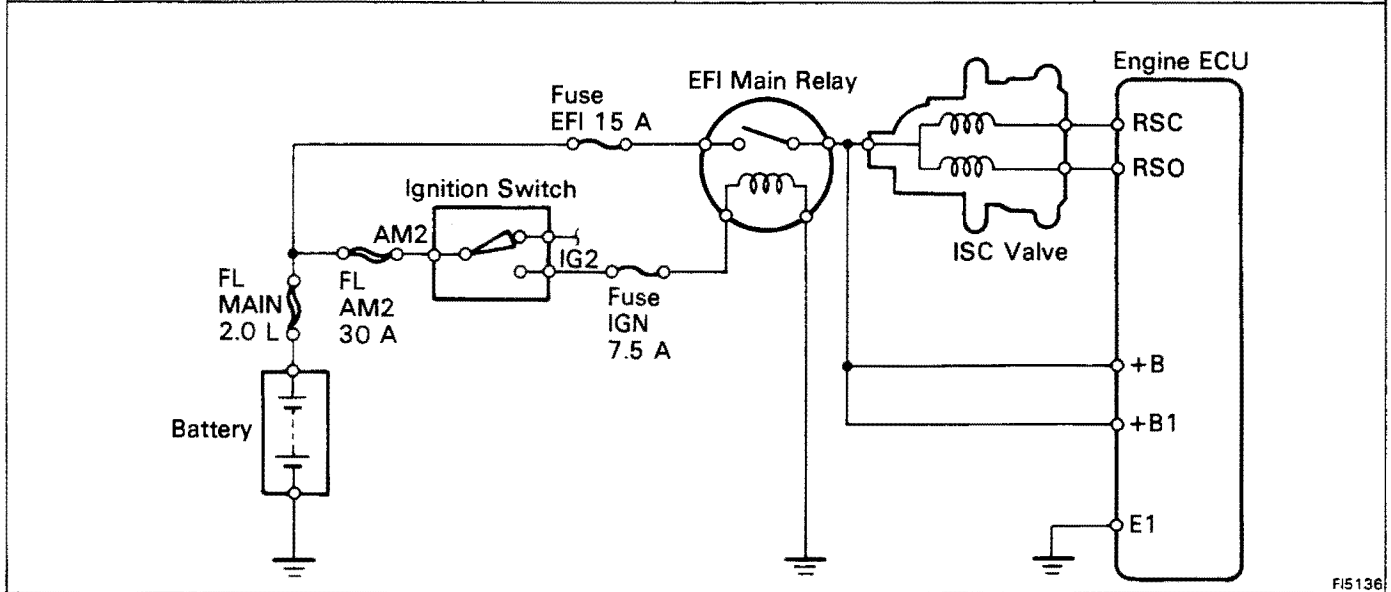

FI5136

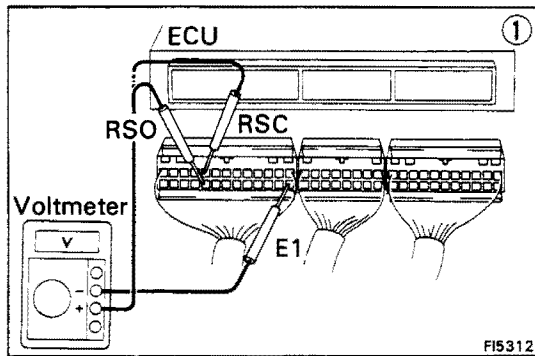

FI5312

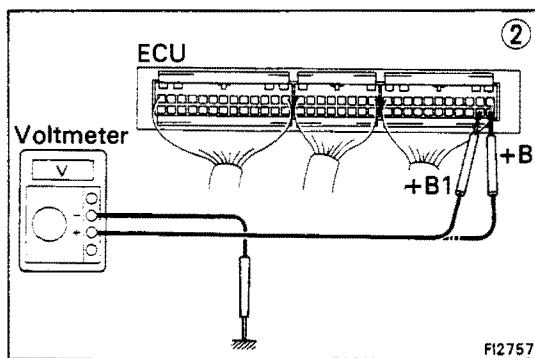

FI2757

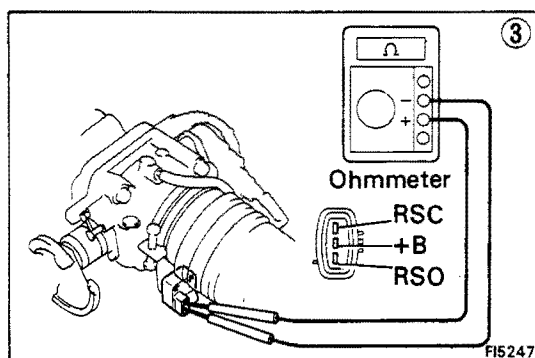

FI5247

① There is no voltage between ECU terminals RSC or RSO and E1. (IG SW ON)

② Check that there is voltage between ECU terminal +B or +B1 and body ground. (IG SW ON)

OK

NO

Refer to +B – E1 trouble section (No.1). (See page FI-72)

Check resistance between ISC valve terminals +B and RSC or RSO.  
③ STD resistance:  
Aprox. 19.3 – 22.3 Ω

BAD

Replace ISC valve.

OK

Check wiring between ECU and ISC valve.

BAD

Repair or replace.

OK

Try another ECU.

No.	Terminals	Trouble	Condition	STD voltage
11	W – E1	No voltage	No trouble ("CHECK" engine warning light off) and engine running.	10 – 14 V

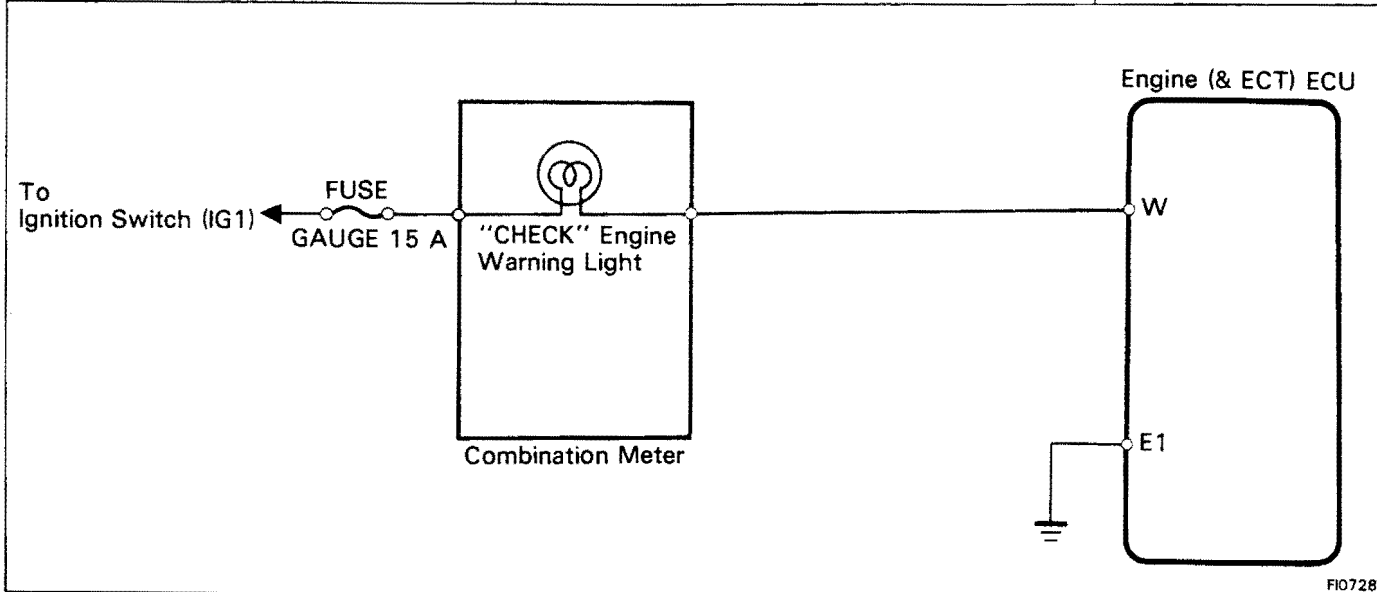

FI0728

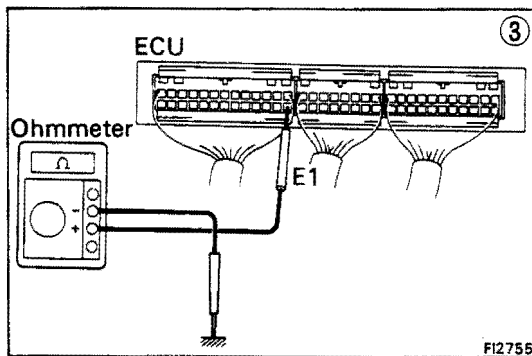
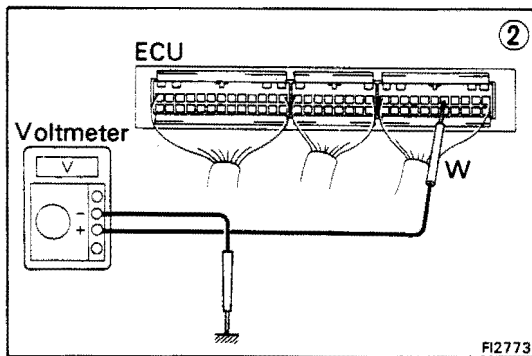
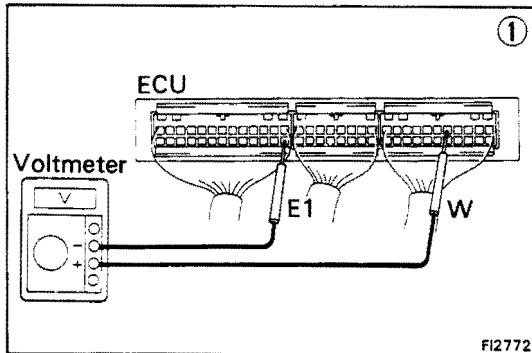

```

    graph TD
      Step1["① There is no voltage between ECU terminals W and E1.  
(Idling)"] --> Step2["② Check that there is voltage between ECU terminal W and  
body ground."]
      Step2 -- NO --> Step3["③ Check wiring between ECU terminal E1 and body  
ground."]
      Step2 -- OK --> Step4["Check GAUGE fuse (15 A) and 'CHECK'  
engine warning light."]
      Step3 -- OK --> TryECU["Try another ECU."]
      Step3 -- BAD --> RepairECU["Repair or replace."]
      Step4 -- OK --> Step5["Check wiring between ECU terminal  
W and fuse."]
      Step4 -- BAD --> RepairFuse["Repair or replace."]
      Step5 -- Fuse blows again --> RepairFuse
      Step5 -- BAD --> RepairW["Repair or replace."]
    
```

No.	Terminals	Trouble	Condition	STD voltage
12	AC1 — E1	No voltage	Air conditioning ON	8 — 14 V

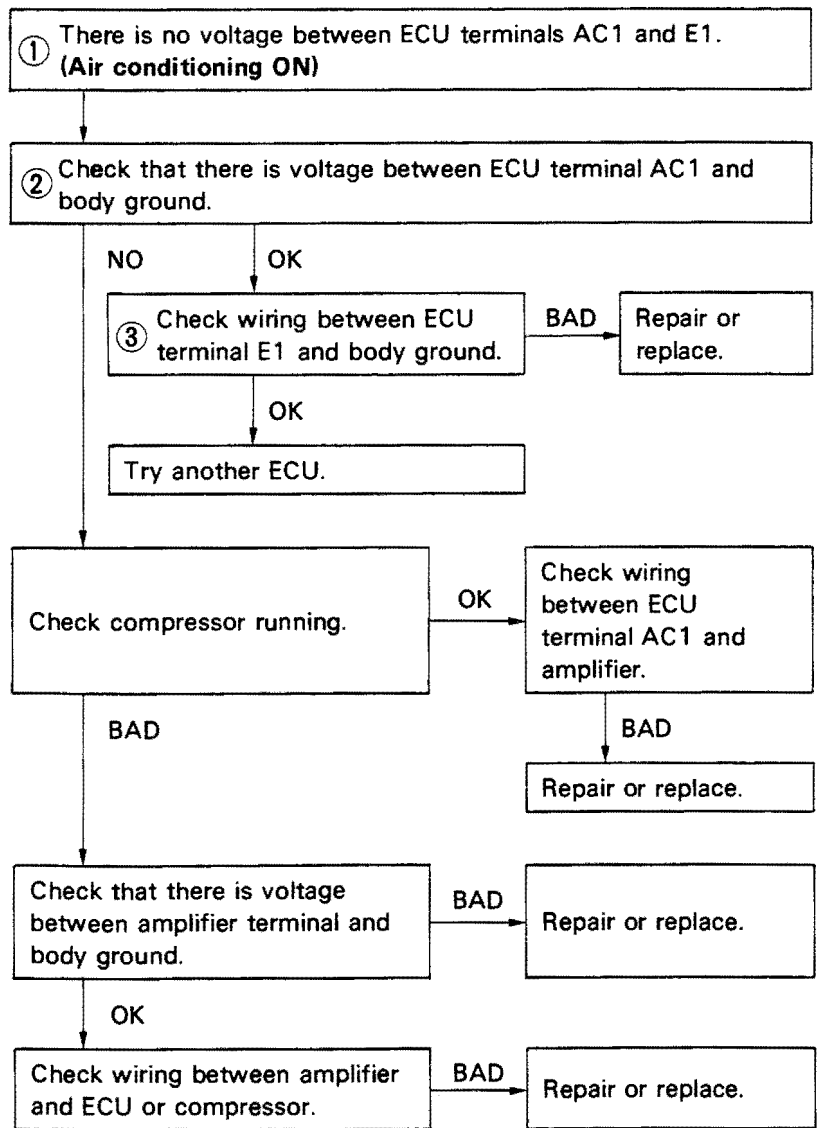
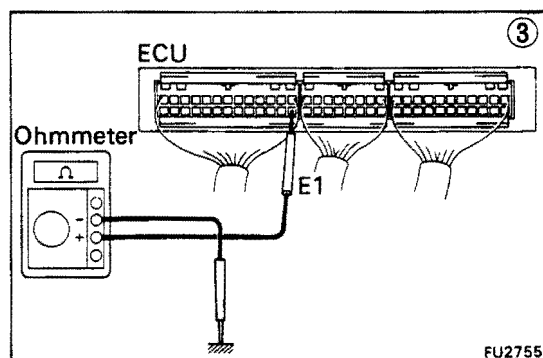
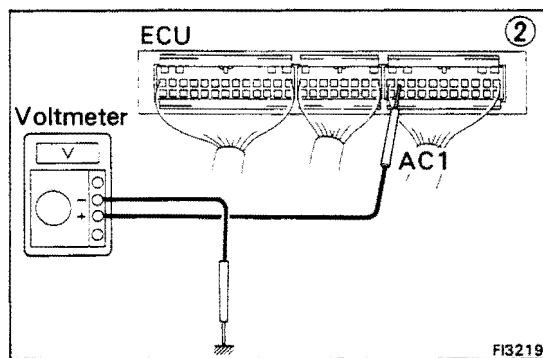
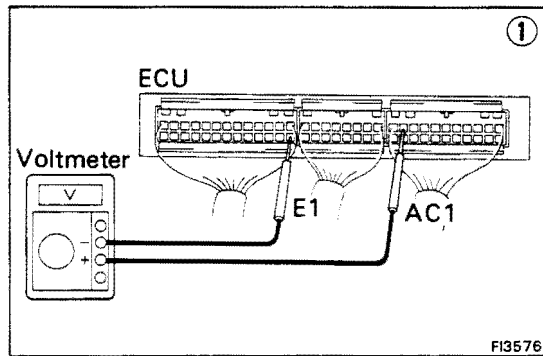
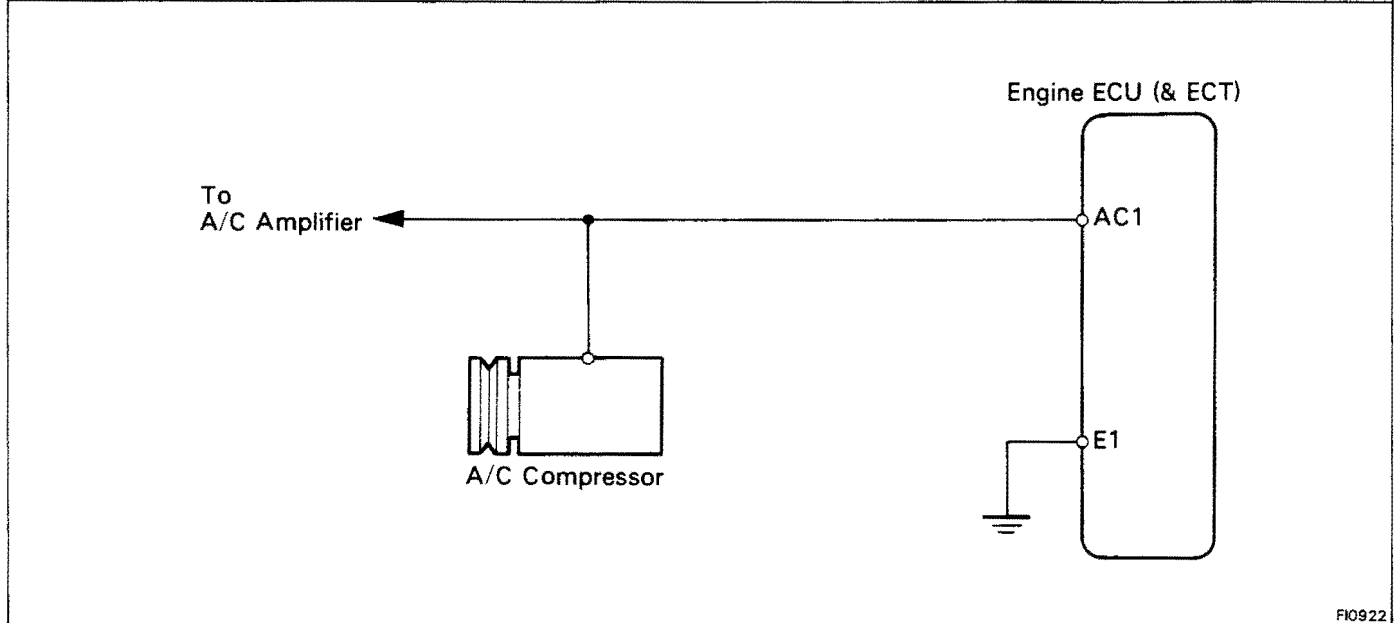



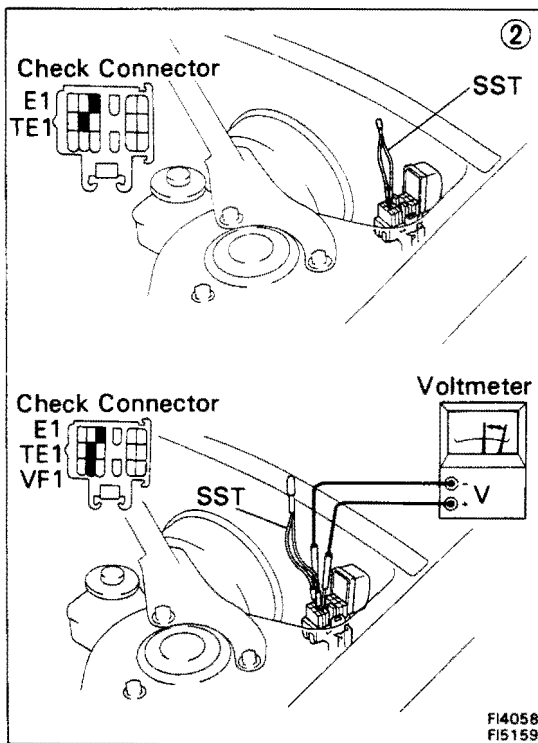
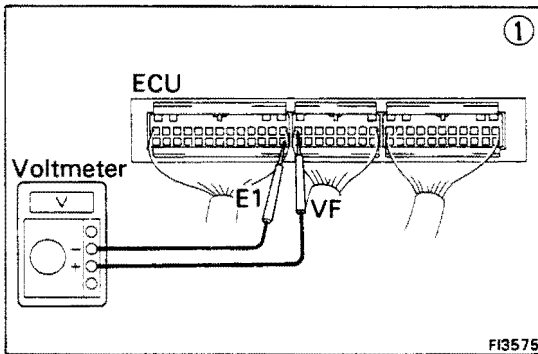
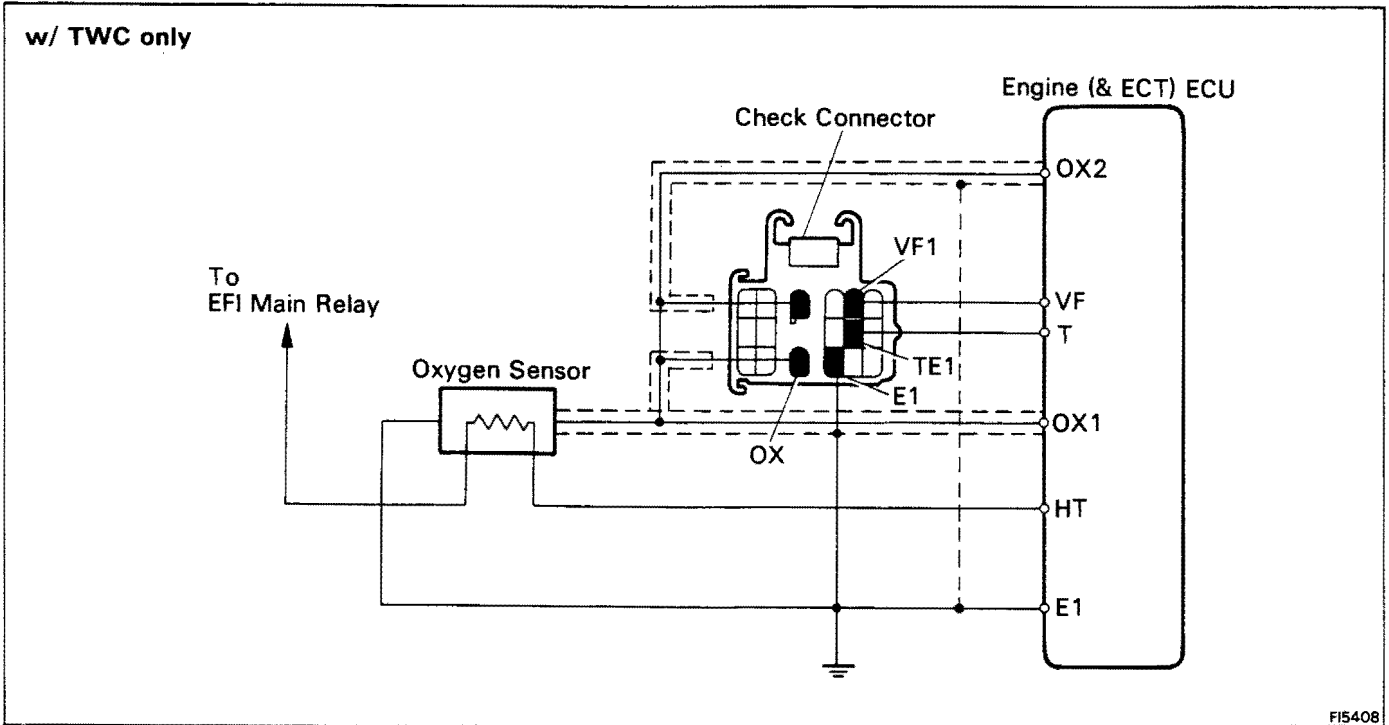

```

    graph TD
      Start[① There is no voltage between ECU terminals VF and E1.] --> CheckVF[Check that there is voltage between ECU terminal VF and body ground.]
      CheckVF -- NO --> CheckE1[Check wiring between ECU terminal E1 and body ground.]
      CheckVF -- OK --> IsAirLeaking[Is air leaking into air induction system?]
      CheckE1 -- OK --> TryECU[Try another ECU.]
      CheckE1 -- BAD --> RepairECU[Repair or replace.]
      IsAirLeaking -- BAD --> RepairAir[Repair or replace.]
      IsAirLeaking -- OK --> CheckSpark[Check spark plugs. (See page IG-7)]
      CheckSpark -- BAD --> RepairSpark[Repair or replace.]
      CheckSpark -- OK --> CheckDistributor[Check distributor and ignition system. (See page IG-4)]
      CheckDistributor -- BAD --> RepairDistributor[Repair or replace.]
      CheckDistributor -- OK --> CheckFuel[Check fuel pressure. (See page FI-108)]
      CheckFuel -- BAD --> RepairFuel[Repair or replace.]
      CheckFuel -- OK --> CheckInjectors[Check injectors. (See page FI-141)]
      CheckInjectors -- BAD --> RepairInjectors[Repair or replace.]
      CheckInjectors -- OK --> CheckColdStart[* Check cold start injector. (See page FI-121)]
      CheckColdStart -- BAD --> RepairColdStart[Repair or replace.]
      CheckColdStart -- OK --> CheckVacuum[Check vacuum sensor. (See page FI-189)]
      CheckVacuum -- BAD --> RepairVacuum[Repair or replace.]
      CheckVacuum -- OK --> CheckOxygen[② Check operation of oxygen sensor. (See page FI-201)]
      CheckOxygen -- OK --> SystemNormal[System normal.]
      CheckOxygen -- BAD --> CheckWiring[Check wiring between oxygen sensor and ECU.]
      CheckWiring -- BAD --> RepairWiring[Repair wiring.]
      CheckWiring -- OK --> ReplaceSensor[Replace oxygen sensor.]
  
```

\*Rich malfunction only

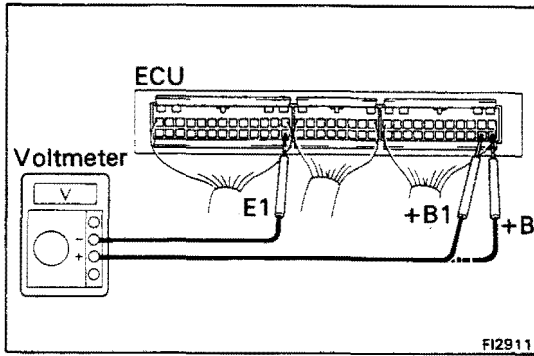

### EFI SYSTEM CHECK PROCEDURE (3S-GTE)

**HINT:**

- Perform all voltage measurements with the connectors connected. (ex. Code No.10)
- Verify that the battery voltage is 11 V or more when the ignition switch is in "ON" position.

Using a voltmeter with high impedance (10 kΩ/V minimum), measure the voltage at each terminal of the wiring connectors.

### Terminals of Engine ECU (3S-GTE)

Symbol	Terminal name	Symbol	Terminal name	Symbol	Terminal name
E01	POWER GROUND	G2	DISTRIBUTOR	/	-
E02	POWER GROUND	G1	DISTRIBUTOR	AC1	A/C MAGNET SWITCH
No.1	INJECTOR	NE	DISTRIBUTOR	ACT	A/C AMPLIFIER
No.3	INJECTOR	E1	ENGINE GROUND	SPD	SPEED SENSOR
No.2	INJECTOR	VF	CHECK CONNECTOR	/	-
No.4	INJECTOR	G ⊖	DISTRIBUTOR	/	-
STJ	COLD START INJECTOR	/	-	/	-
EGR	EGR VSV	T	CHECK CONNECTOR	/	-
RSC	ISC VALVE	OX1	CHECK CONNECTOR	/	-
RSO	ISC VALVE	OX2	CHECK CONNECTOR	FPR	FUEL PUMP RELAY
HT	OXYGEN SENSOR HEATER	KNK	KNOCK CONTROL SENSOR	/	-
/	-	PIM	TURBOCHARGING PRESSURE SENSOR	W	WARNING LIGHT
/	-	THW	WATER TEMP. SENSOR	/	-
IGT	IGNITER	IDL	THROTTLE POSITION SENSOR	STP	STOP LIGHT SWITCH
TPC1	TURBOCHARGING PRESSURE VSV	THA1	AIR TEMP. SENSOR	/	-
/	-	VTA	THROTTLE POSITION SENSOR	/	-
/	-	VS	AIR FLOW METER	/	-
TVIS	INTAKE AIR VSV	/	-	ELS	TAILLIGHT and DEFOGGER
/	-	VC	SENSOR POWER SOURCE	+B1	MAIN RELAY
FC	CIRCUIT OPENING RELAY	E2	SENSOR GROUND	BATT	BATTERY
IGF	IGNITER	STA	STARTER SWITCH	+B	MAIN RELAY

**Engine ECU Terminals**

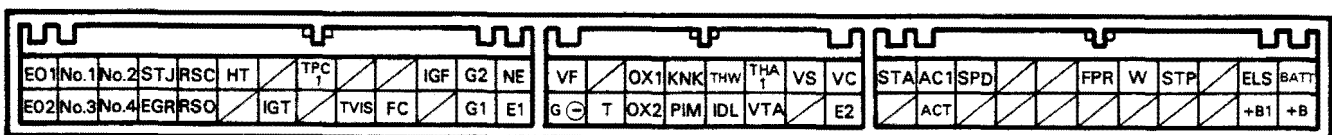

### Voltage at Engine ECU Wiring Connectors (3S-GTE)

No.	Terminals	Condition		STD voltage (V)	See page
1	+B +B1 - E1	IG SW ON		10 - 14	FI-88
2	BATT - E1	-		10 - 14	FI-89
3	IDL - E2	IG SW ON	Throttle valve open	4 - 6	FI-90
	VC - E2		-	4 - 6	
	VTA - E2		Throttle valve fully closed	0.1 - 1.0	
			Throttle valve open	4 - 5	
4	VC - E2	IG SW ON	-	4 - 6	FI-92
	VS - E2		Measuring plate fully closed	3.7 - 4.3	
			Measuring plate fully open	0.2 - 0.5	
	Idling	-	2.3 - 3.8		
	3,000 rpm	-	1.0 - 2.0		
5	No.1 No.2 - E01 No.3 - E02 No.4	IG SW ON		10 - 14	FI-93
6	THA1 - E2	IG SW ON	Intake air temp. 20°C (68°F)	1 - 3	FI-94
7	THW - E2		Coolant temp. 80°C (176°F)	0.1 - 1.0	FI-95
8	STA - E1	Cranking		6 - 14	FI-96
9	IGT - E1	Idling		0.7 - 1.0	FI-97
10	RSC RSO - E1	IG SW ON	Engine ECU connectors disconnected	8 - 14	FI-98
11	W - E1	No trouble ("CHECK" engine warning light off) and engine running		10 - 14	FI-99
12	PIM - E2	IG SW ON		2.5 - 4.5	FI-100
	VC - E2			4 - 6	
13	AC1 - E1	IG SW ON	Air conditioning ON	8 - 14	FI-101

**Engine ECU Terminals**

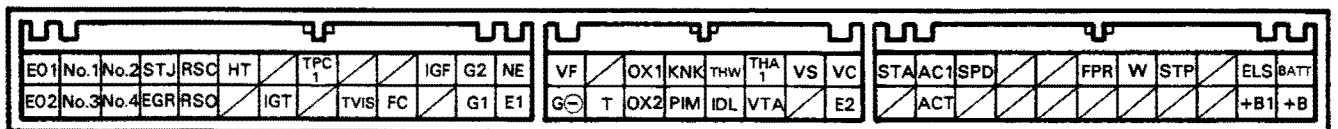

No.	Terminals	Trouble	Condition	STD voltage
1	+B +B1 - E1	No voltage	IG SW ON	10 - 14 V

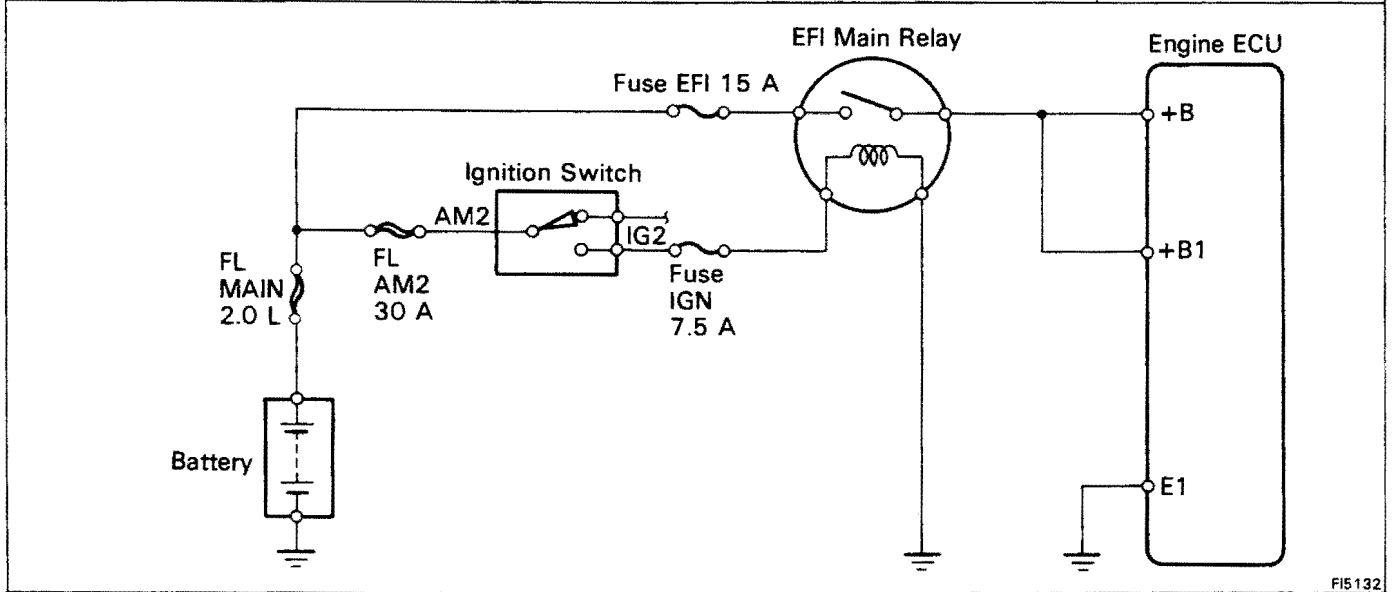

FI5132

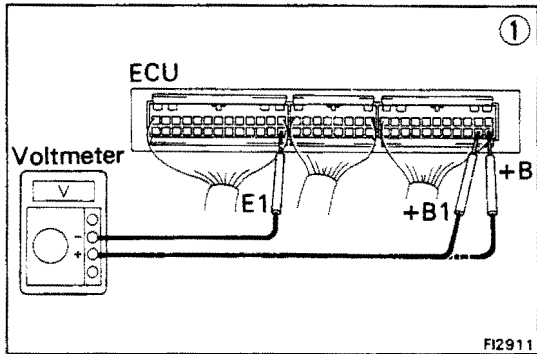

FI2911

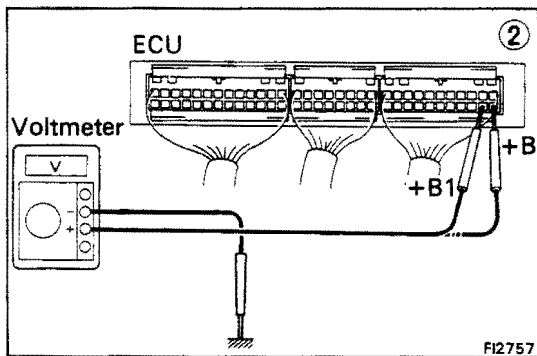

FI2757

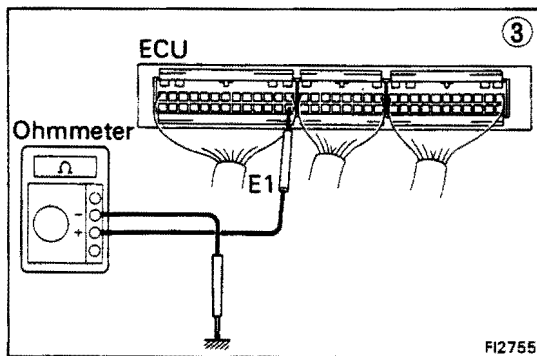

FI2755

```

    graph TD
      Step1["1 There is no voltage between ECU terminals +B or +B1 and E1. (IG SW ON)"]
      Step2["2 Check that there is voltage between ECU terminal +B or +B1 and body ground. (IG SW ON)"]
      Step3["3 Check wiring between ECU terminal E1 and body ground."]
      CheckFuses["Check fuses, fusible links and ignition switch."]
      CheckRelay["Check EFI main relay. (See page FI-182)"]
      CheckWiring["Check wiring between EFI main relay and battery."]
      TryECU["Try another ECU."]
      RepairECU["Repair or replace."]
      RepairFuses["Repair or replace."]
      ReplaceRelay["Replace."]
      RepairWiring["Repair or replace."]

      Step1 --> Step2
      Step2 -- NO --> CheckFuses
      Step2 -- OK --> Step3
      Step3 -- OK --> CheckRelay
      Step3 -- BAD --> RepairECU
      CheckFuses -- BAD --> RepairFuses
      CheckFuses -- OK --> CheckRelay
      CheckRelay -- BAD --> ReplaceRelay
      CheckRelay -- OK --> CheckWiring
      CheckWiring -- BAD --> RepairWiring
      CheckWiring -- OK --> End
  
```

No.	Terminals	Trouble	Condition	STD voltage
2	BATT — E1	No voltage	—	10 — 14 V

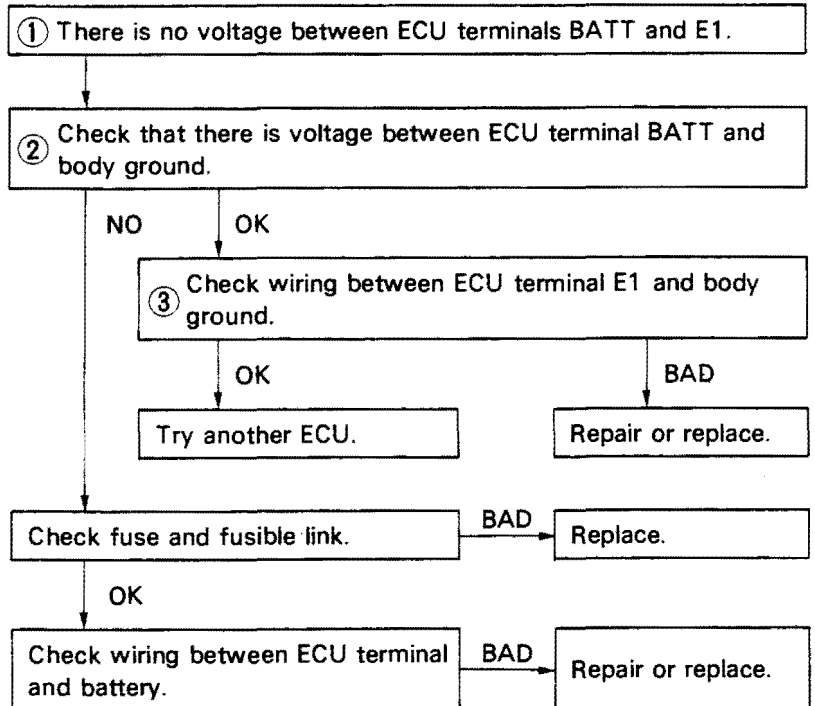
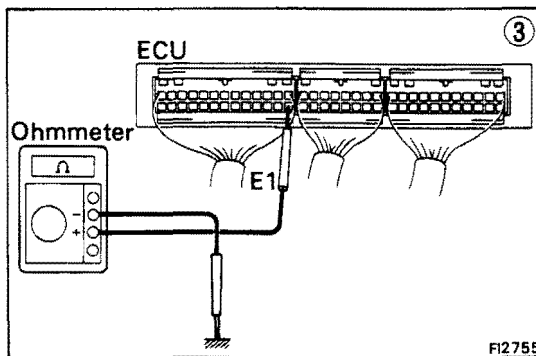
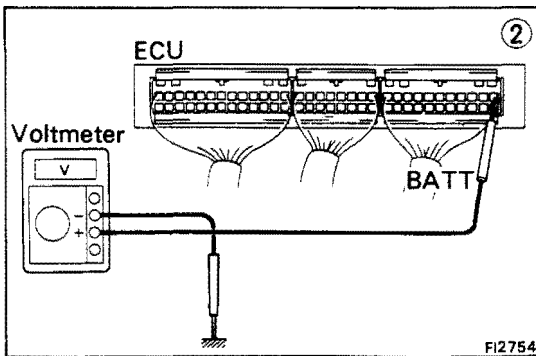
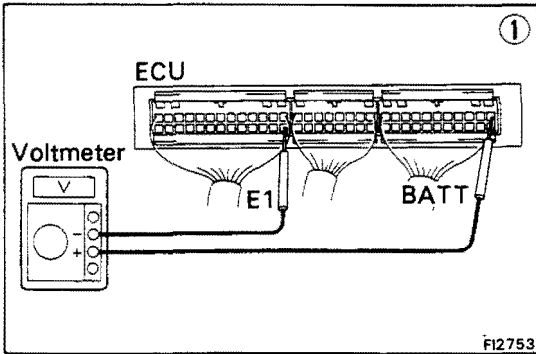
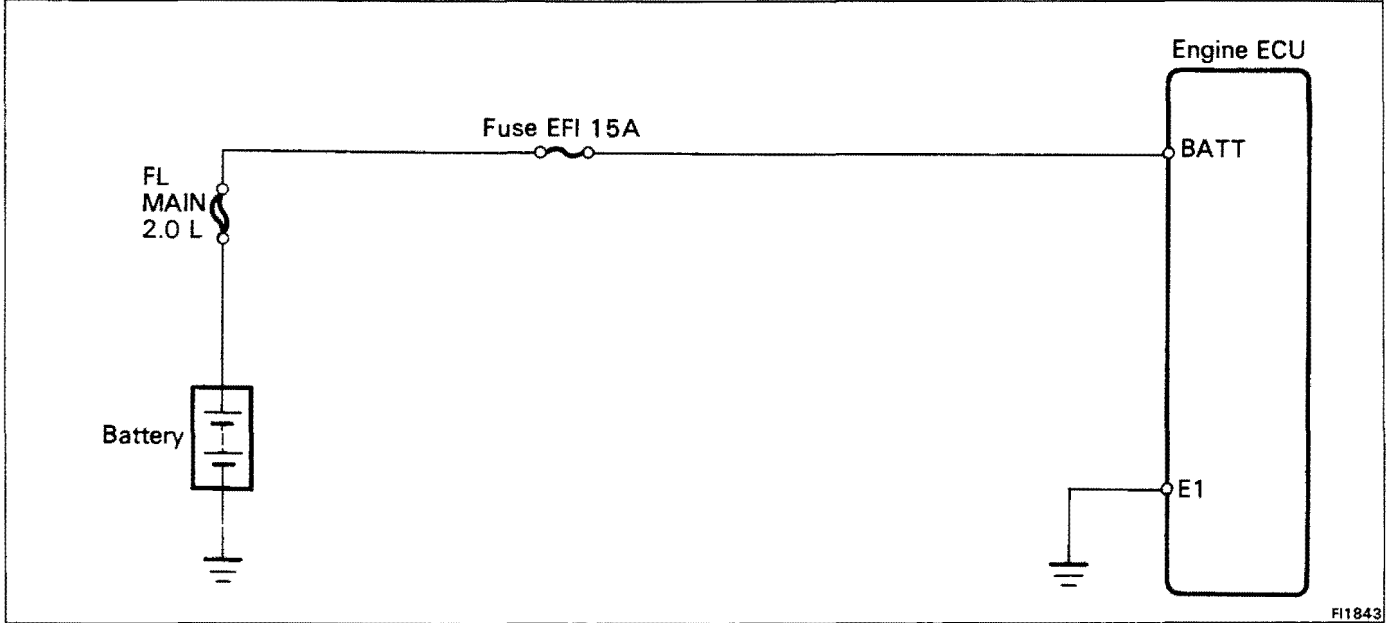

No.	Terminals	Trouble	Condition	STD Voltage	
3	IDL — E2	No voltage	Ignition switch ON	Throttle valve open	4 — 6 V
	VC — E2			—	4 — 6 V
	VTA — E2			Throttle valve fully closed	0.1 — 1.0 V
				Throttle valve fully open	4 — 5 V

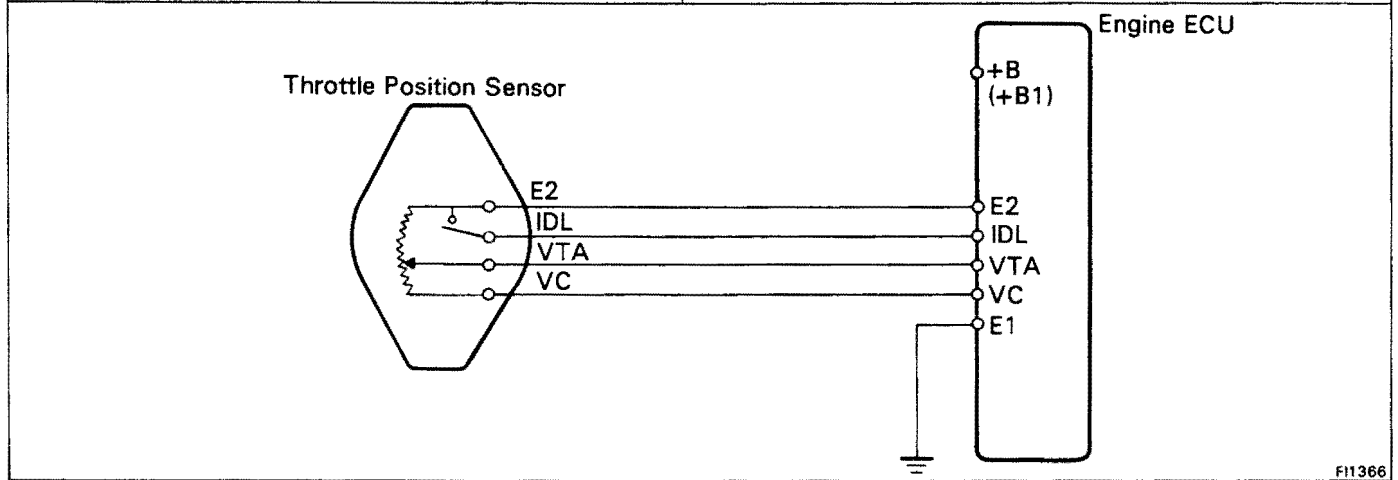

FI1366

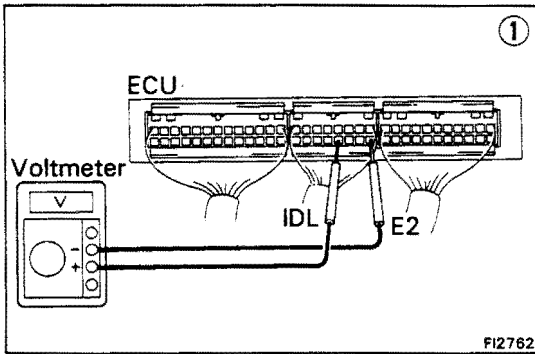

FI2762

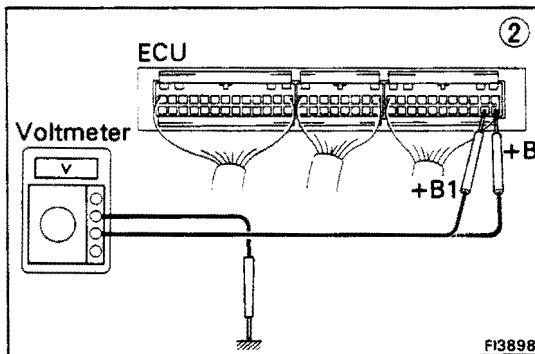

FI3898

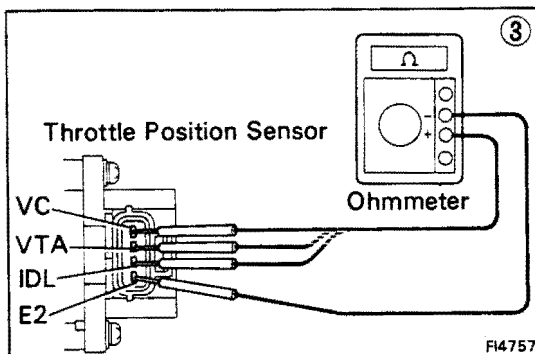

FI4757

• IDL — E2

```

    graph TD
      A["① There is no voltage between ECU terminals IDL and E2.  
(IG SW ON) (Throttle valve open)"] --> B["② Check that there is voltage between ECU terminal +B or +B1  
and body ground. (IG SW ON)"]
      B -- NO --> C["Refer to +B — E1 trouble section (No.1).  
(See page FI-88)"]
      B -- OK --> D["Check wiring between ECU terminal E1 and body  
ground."]
      D -- OK --> E["Try another ECU."]
      D -- BAD --> F["Repair or replace."]
      C -- BAD --> G["Repair or replace."]
      C -- OK --> H["③ Check throttle position  
sensor. (See page FI-169)"]
      H -- BAD --> I["Repair or replace.  
throttle position sensor."]
      H -- OK --> J["Check wiring between ECU and  
throttle position sensor."]
      J -- OK --> K["Try another ECU."]
  
```

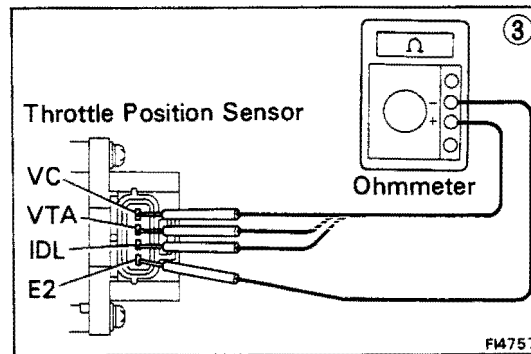
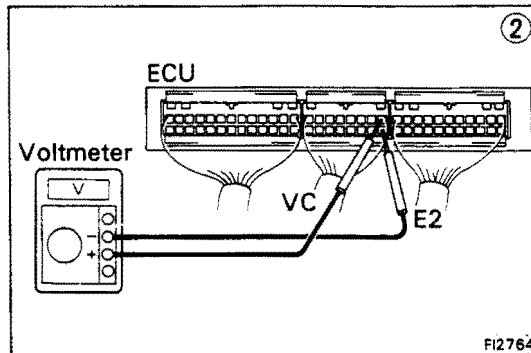
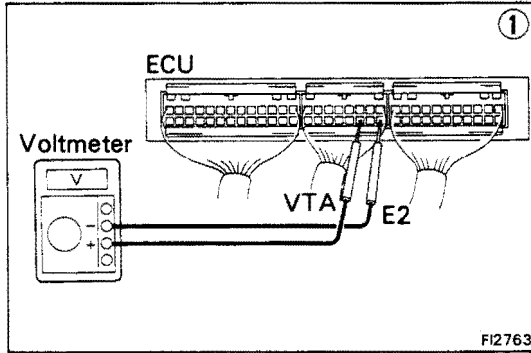
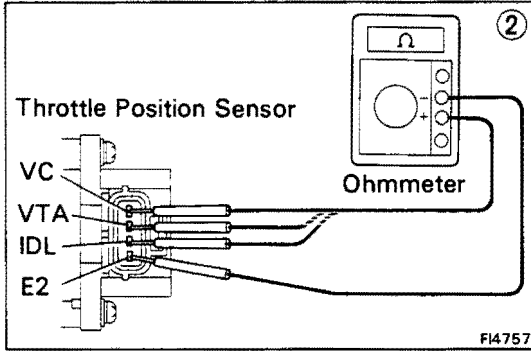
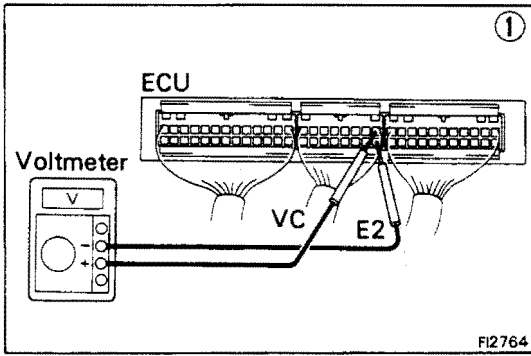

• VC – E2

```

    graph TD
      A["① No voltage between ECU terminals VC and E2.  
(IG SW ON)"] --> B["Check that there is voltage between ECU terminal +B or +B1  
and body ground. (IG SW ON)"]
      B -- OK --> C["② Check throttle position sensor.  
(See page FI-169)"]
      B -- NO --> D["Refer to +B – E1 trouble  
section (No.1).  
(See page FI-88)"]
      C -- BAD --> E["Repair or replace."]
      C -- OK --> F["Check wiring between ECU and throttle  
position sensor."]
      F -- OK --> G["Try another ECU."]
      F -- BAD --> H["Repair or replace."]
    
```

• VTA – E2

```

    graph TD
      A["① No specified voltage at ECU terminals VTA and E2.  
(IG SW ON)"] --> B["② Check that there is voltage between ECU terminals VC and E2.  
(IG SW ON)"]
      B -- NO --> C["Refer to VC – E2  
trouble section."]
      B -- OK --> D["③ Check throttle position sensor.  
(See page FI-169)"]
      D -- BAD --> E["Repair or replace."]
      D -- OK --> F["Check wiring between ECU and  
throttle position sensor."]
      F -- BAD --> G["Repair or replace."]
      F -- OK --> H["Try another ECU."]
    
```

No.	Terminals	Trouble	Condition	STD Voltage	
4	VC — E2	No voltage	Ignition SW ON	—	4 — 6 V
				Measuring plate fully closed	3.7 — 4.3 V
	Measuring plate fully open			0.2 — 0.5 V	
	VS — E2		Idling	—	2.3 — 2.8 V
			3,000 rpm	—	1.0 — 2.0 V

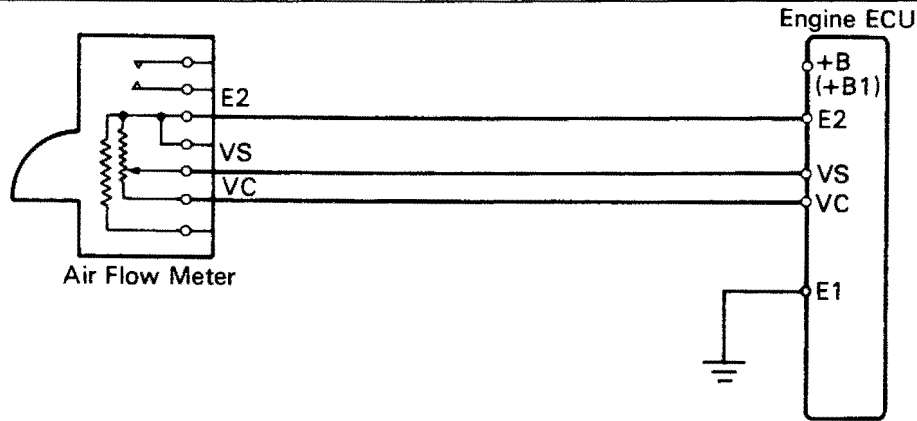

FI1269

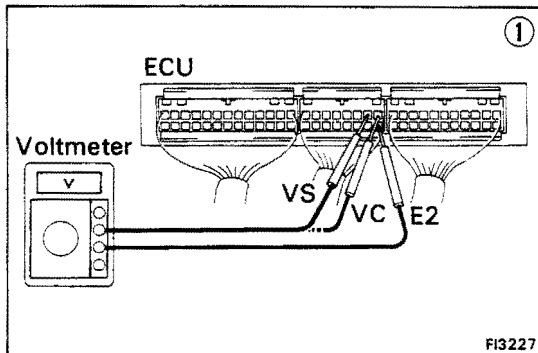

FI3227

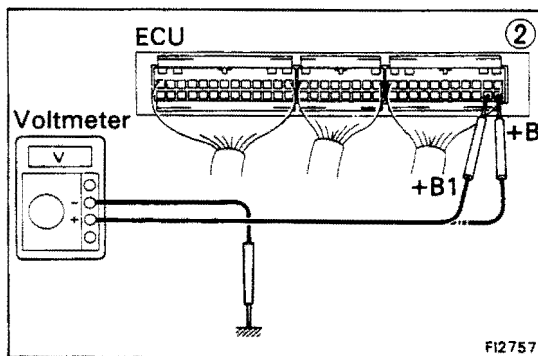

FI2757

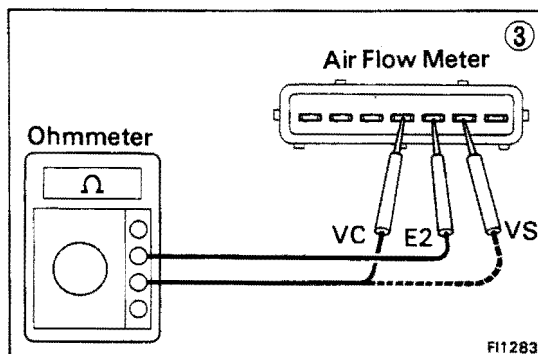

FI1283

```

    graph TD
      Step1["① There is no voltage between ECU terminals VC or VS and E2. (IG SW ON)"]
      Step2["② Check that there is voltage between ECU terminal +B or +B1 and body ground. (IG SW ON)"]
      Step3["③ Check air flow meter. (See page FI-155)"]
      Step4["Check wiring between ECU terminal E1 and body ground."]
      Step5["Check wiring between ECU and air flow meter."]
      Step6["Try another ECU."]
      Step7["Replace air flow meter."]
      Step8["Repair or replace."]
      Step9["Repair or replace."]

      Step1 --> Step2
      Step2 -- NO --> Step8
      Step2 -- OK --> Step4
      Step4 -- BAD --> Step7
      Step4 -- OK --> Step3
      Step3 -- BAD --> Step7
      Step3 -- OK --> Step5
      Step5 -- BAD --> Step9
      Step5 -- OK --> Step6
  
```



No.	Terminals	Trouble	Condition	STD Voltage
5	No.1 No.2 — E01 No.3 — E02 No.4	No voltage	IG SW ON	10 — 14 V

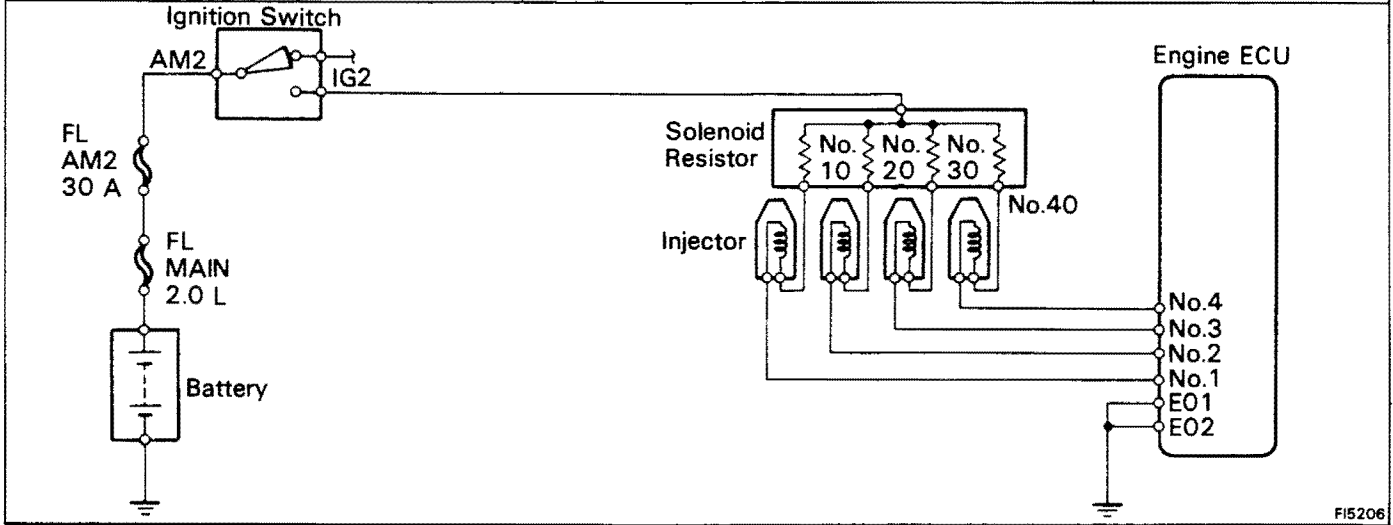

FI5206

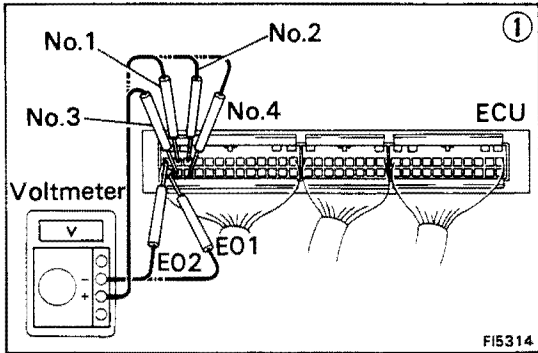

FI5314

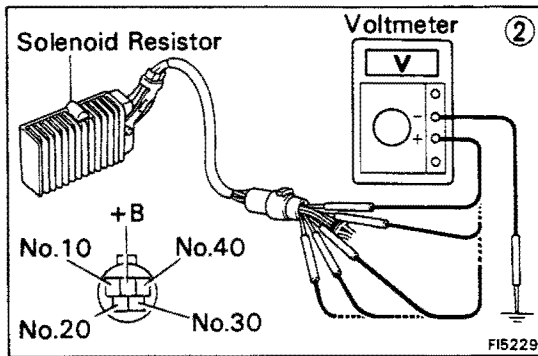

FI5229

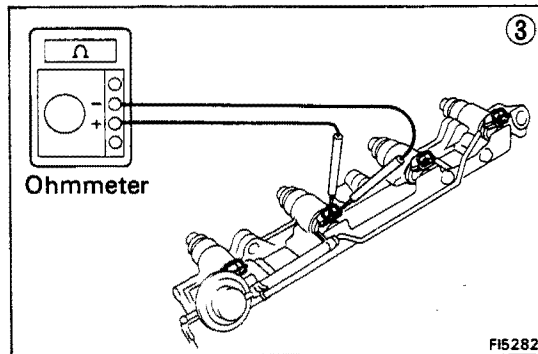

FI5282

```

    graph TD
      Step1["① There is voltage between ECU terminals No.1, No.2, No.3 and/or No.4 and E01 and/or E02. (IG SW ON)"]
      Step2["② Check that there is specified voltage between solenoid resistor terminal +B and body ground. STD voltage: 10 - 14 V"]
      Step3["③ Check resistance of each injector. STD resistance: 2 - 4 Ω"]
      Step4["Try another ECU."]
      
      Step1 --> Step2
      Step2 -- NO --> CheckWiring["Check fusible links, wiring and ignition switch."]
      CheckWiring -- BAD --> RepairECU["Repair or replace."]
      Step2 -- OK --> Step3
      Step3 -- NO --> ReplaceResistor["Replace resistor."]
      Step3 -- OK --> CheckWiringECU["Check wiring between ECU and resistor."]
      CheckWiringECU -- BAD --> RepairECU
      CheckWiringECU -- OK --> Step4
  
```

No.	Terminals	Trouble	Condition		STD Voltage
6	THA1 — E2	No voltage	IG SW ON	Intake air temperature 20°C (68°F)	1 — 3 V

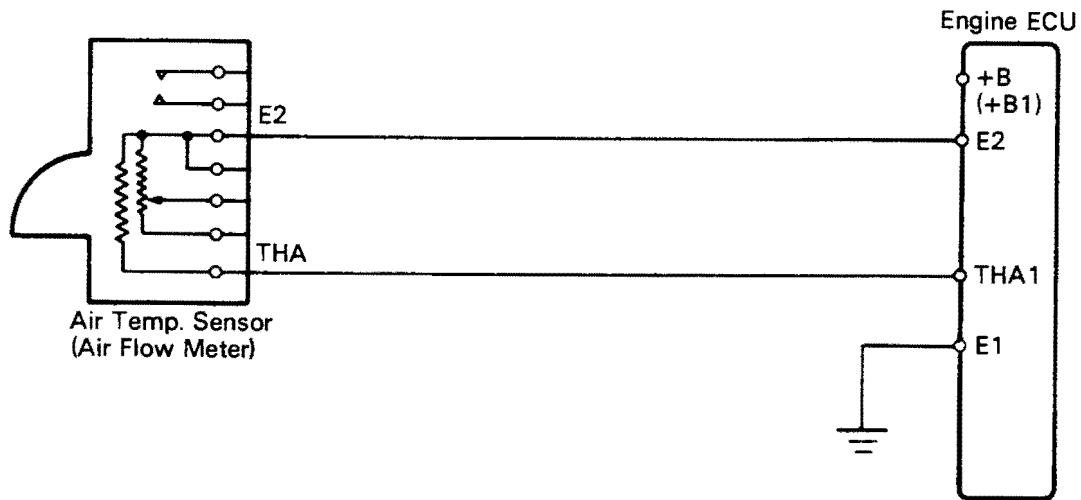

FI1272

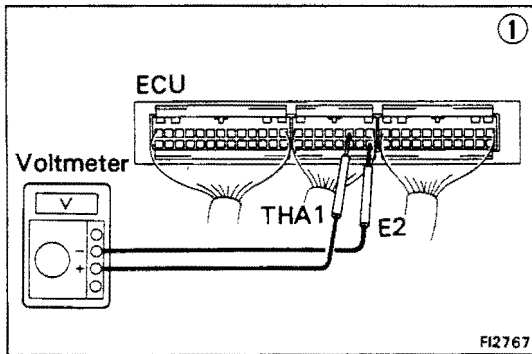

① There is no voltage between ECU terminals THA1 or E2. (IG SW ON)

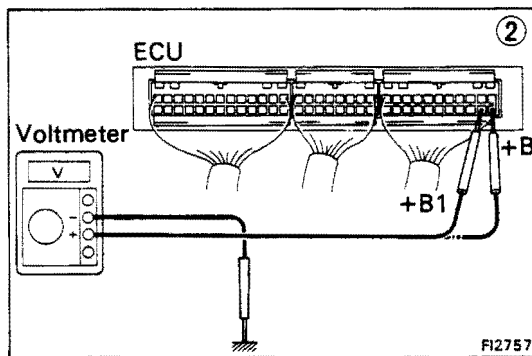

② Check that there is voltage between ECU terminal +B (+B1) and body ground. (IG SW ON)

OK

NO

Refer to +B — E1 trouble section No.1. (See page FI-88)

Check wiring between ECU terminal E1 and body ground.

OK

BAD

③ Check air temp. sensor. (See page FI-155)

Repair or replace.

BAD

OK

Replace air flow meter.

Check wiring between ECU and air temp. sensor.

OK

BAD

Try another ECU.

Repair or replace.

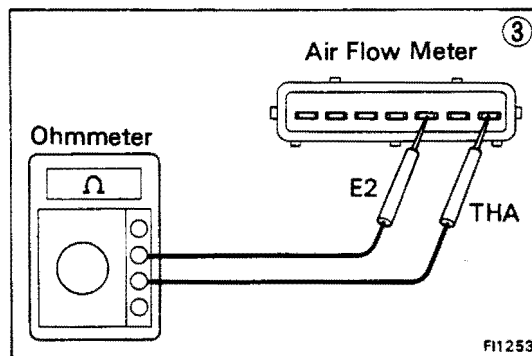

FI1253

No.	Terminals	Trouble	Condition	STD Voltage
7	THW — E2	No voltage	IG SW ON Coolant temperature 80°C (176°F)	0.1 — 1.0 V

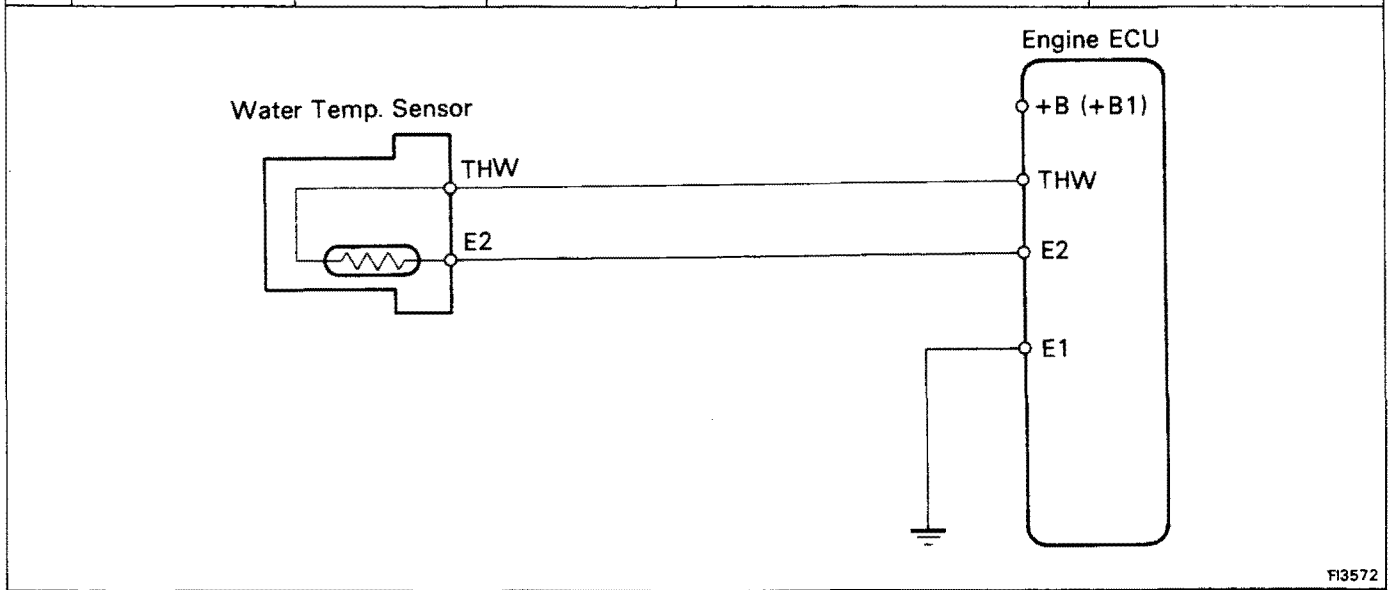

FI3572

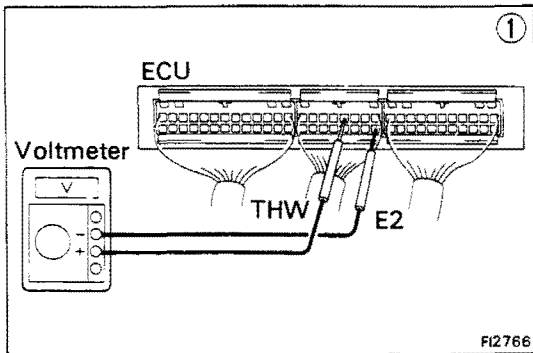

① There is no voltage between ECU terminals THW and E2. (IG SW ON)

② Check that there is voltage between ECU terminal +B or +B1 and body ground. (IG SW ON)

NO  
Refer to +B — E1 trouble section (No.1). (See page FI-88)

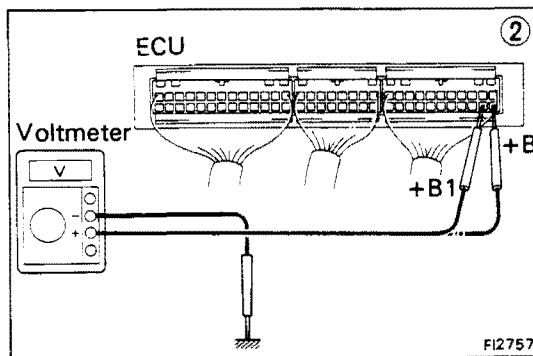

Check wiring between ECU terminal E1 and body ground.

OK  
③ Check water temp. sensor. (See page FI-186)

BAD  
Repair or replace.

BAD  
Replace water temp. sensor.

OK  
Check wiring between ECU and water temp. sensor.

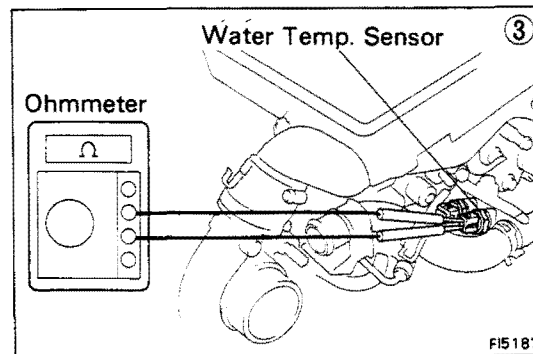

OK  
Try another ECU.

BAD  
Repair or replace.

FI5187

No.	Terminals	Trouble	Condition	STD Voltage
8	STA – E1	No voltage	Cranking	6 – 14 V

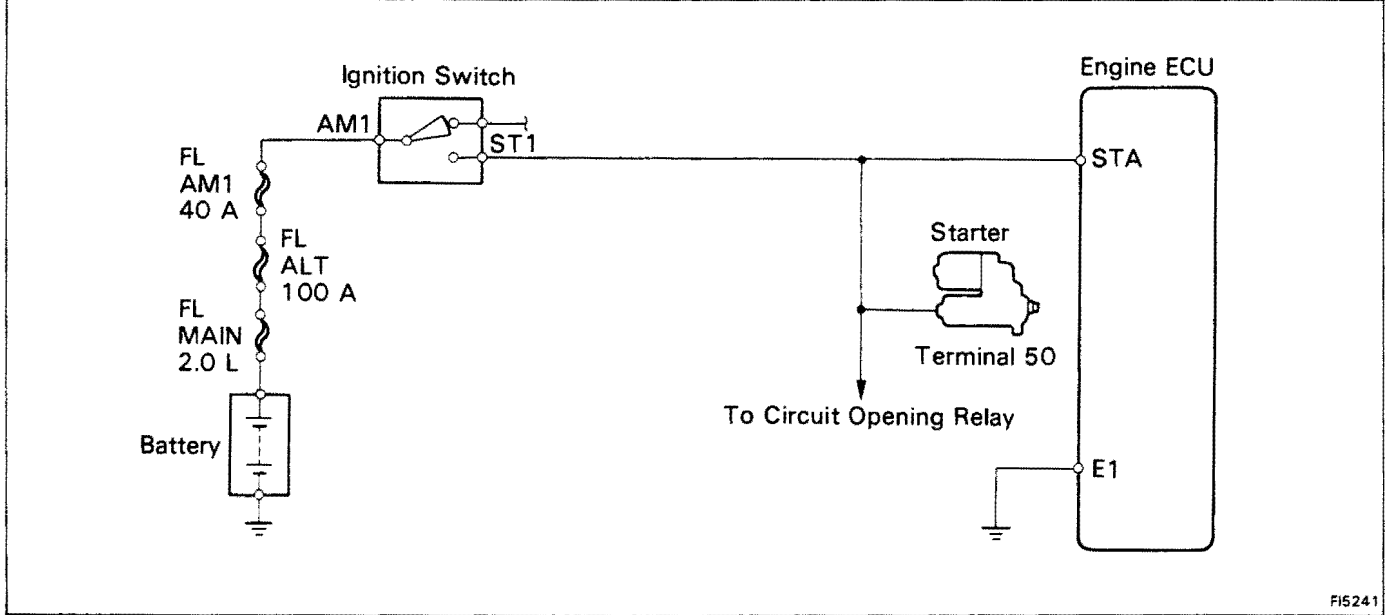

FI5241

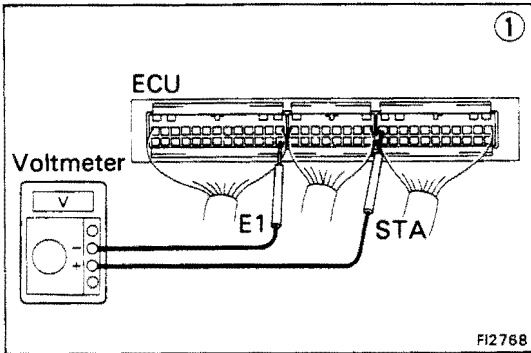

FI2768

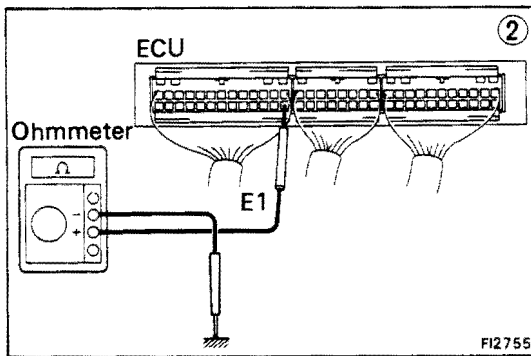

FI2755

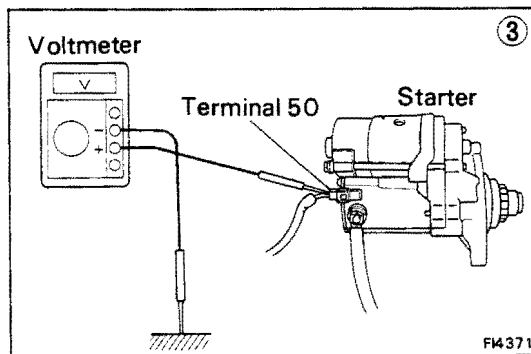

FI4371

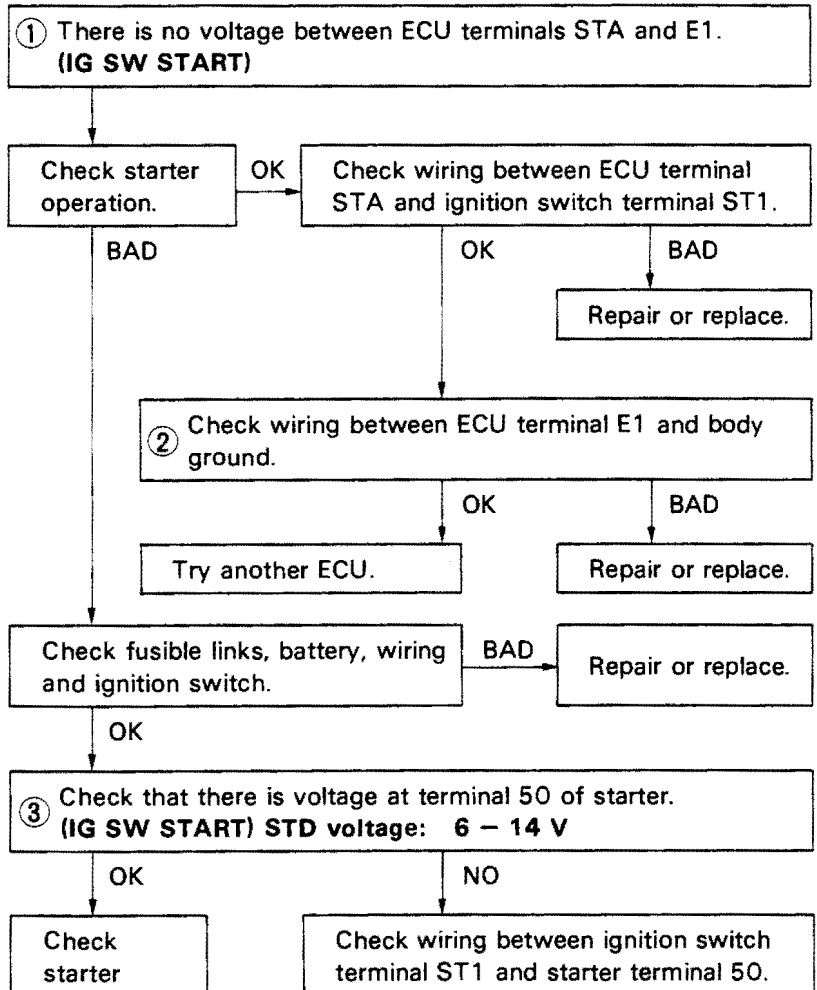

No.	Terminals	Trouble	Condition	STD Voltage
9	IGT — E1	No voltage	Idling	0.7 — 1.0 V

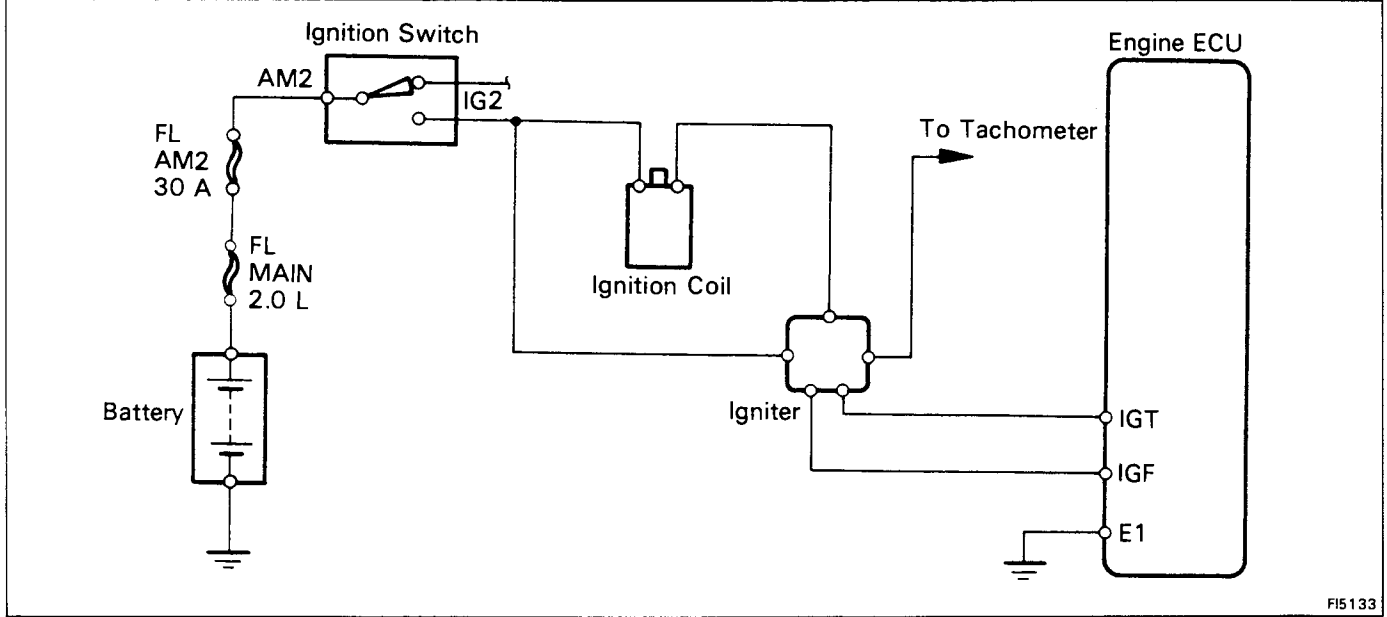

FI5133

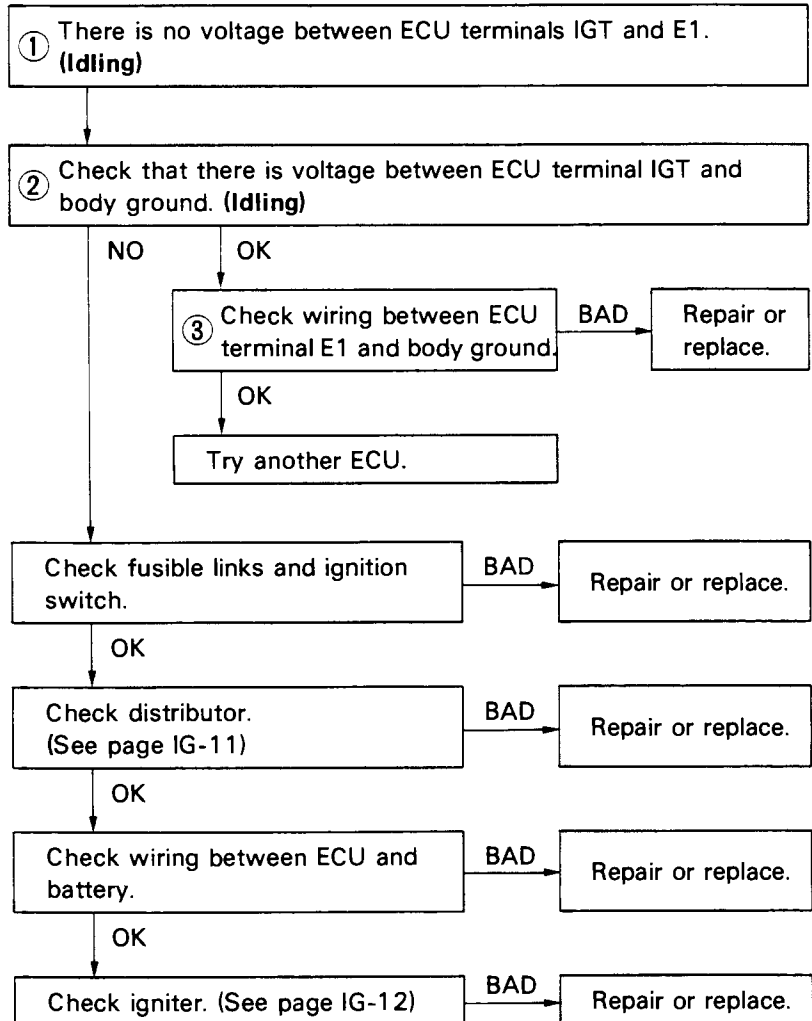
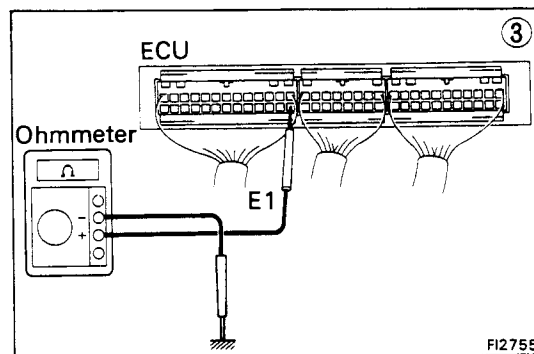
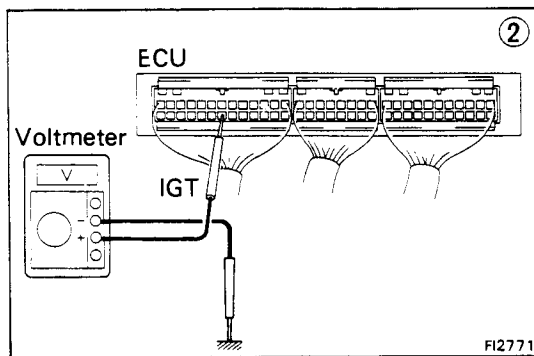
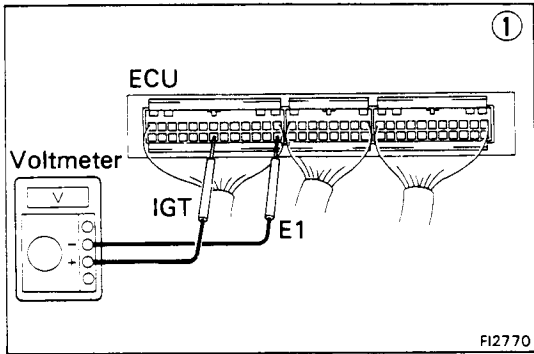

No.	Terminals	Trouble	Condition		STD Voltage
10	RSC RSO — E1	No voltage	IG SW ON	Engine ECU connectors disconnected	8 — 14 V

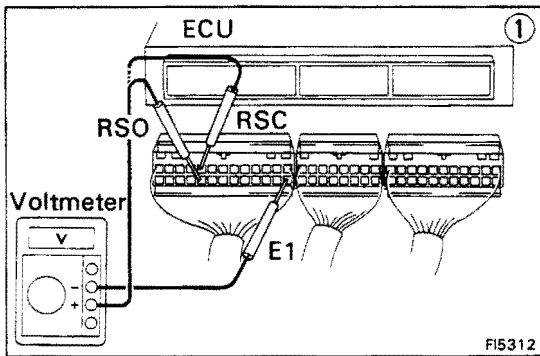
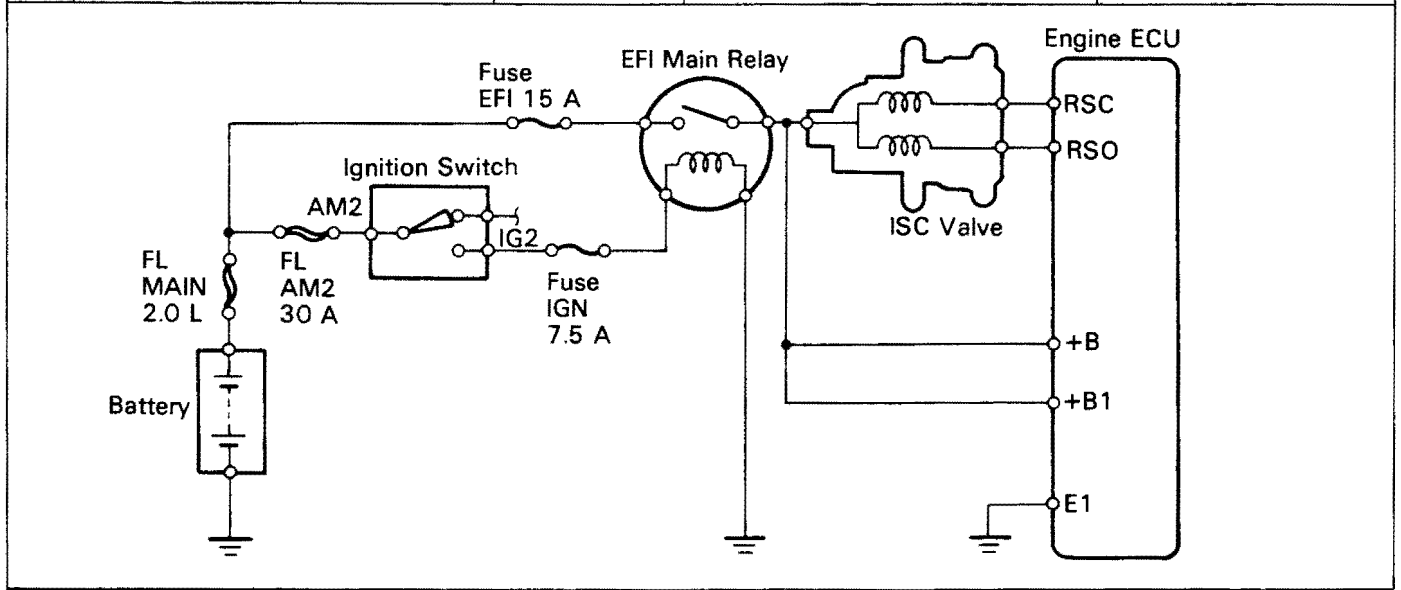

① There is no voltage between ECU terminals RSC or RSO and E1. (IG SW ON)

② Check that there is voltage between ECU terminal +B or +B1 and body ground. (IG SW ON)

OK

NO

Refer to +B — E1 trouble section (No.1). (See page FI-72)

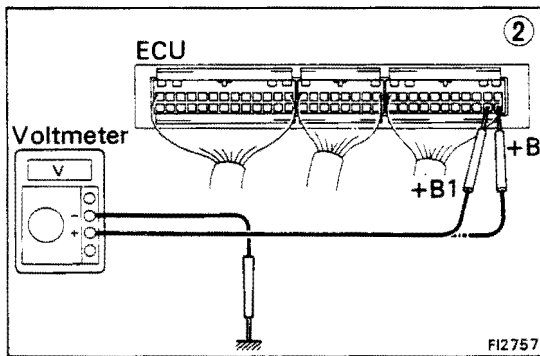

Check resistance between ISC valve terminals +B and RSC or RSO.  
③ STD resistance:  
Approx. 19.3 — 22.3 Ω

BAD

Replace ISC valve.

OK

Check wiring between ECU and ISC valve.

BAD

Repair or replace.

OK

Try another ECU.

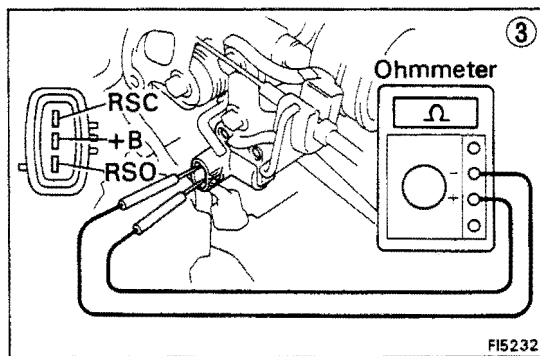

No.	Terminals	Trouble	Condition	STD Voltage
11	W – E1	No voltage	No trouble ("CHECK" engine warning light off) and engine running.	10 – 14 V

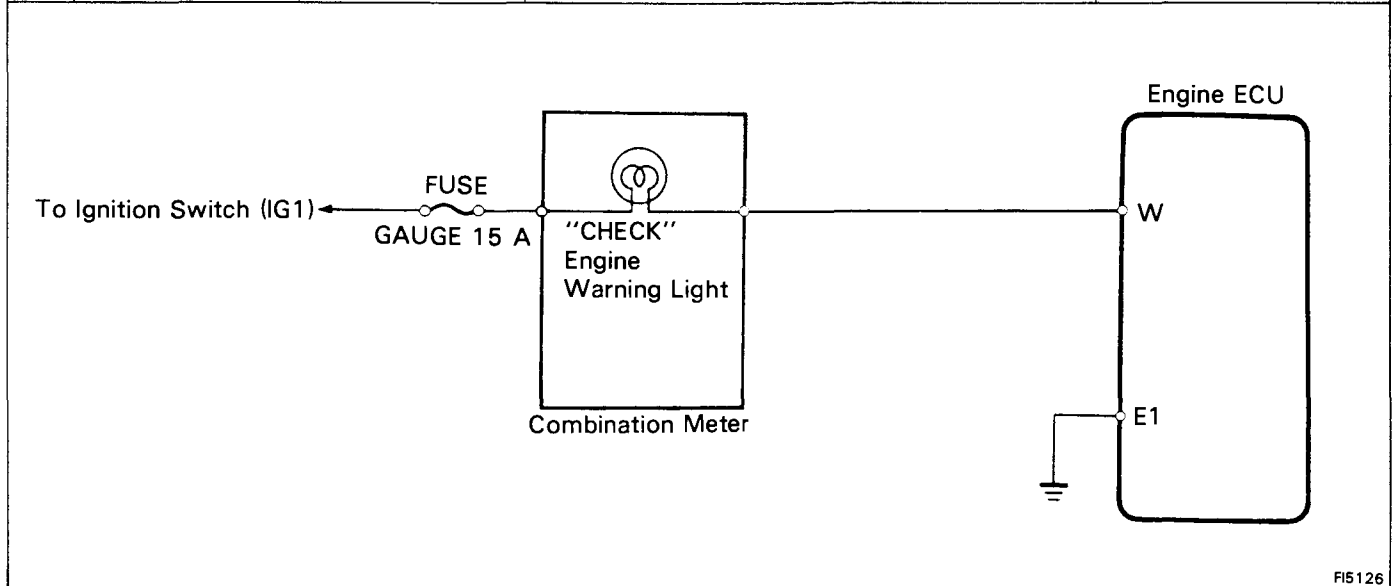

FI5126

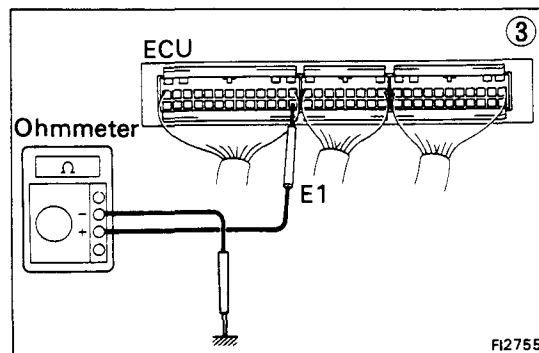
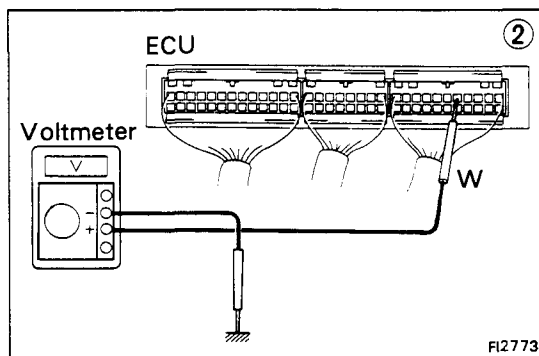
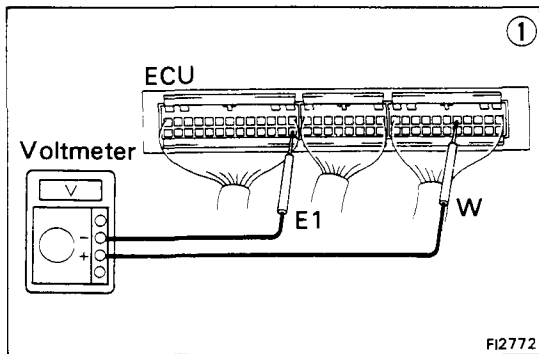

```

    graph TD
      Step1["① There is no voltage between ECU terminals W and E1.  
(Idling)"] --> Step2["② Check that there is voltage between ECU terminal W and  
body ground."]
      Step2 -- NO --> FuseCheck["Check GAUGE fuse (15 A) and 'CHECK' engine warning light."]
      Step2 -- OK --> Step3["③ Check wiring between ECU terminal E1 and body ground."]
      Step3 -- OK --> TryECU["Try another ECU."]
      Step3 -- BAD --> RepairECU["Repair or replace."]
      FuseCheck -- OK --> Step3
      FuseCheck -- BAD --> RepairFuse["Repair or replace."]
      RepairFuse -- Fuse blows again --> FuseWCheck["Check wiring between ECU terminal W and fuse."]
      FuseWCheck -- BAD --> RepairW["Repair or replace."]
  
```

No.	Terminals	Trouble	Condition	STD Voltage
12	PIM — E2	No voltage	IG SW ON	2.5 — 4.5 V
	VC — E2			4 — 6 V

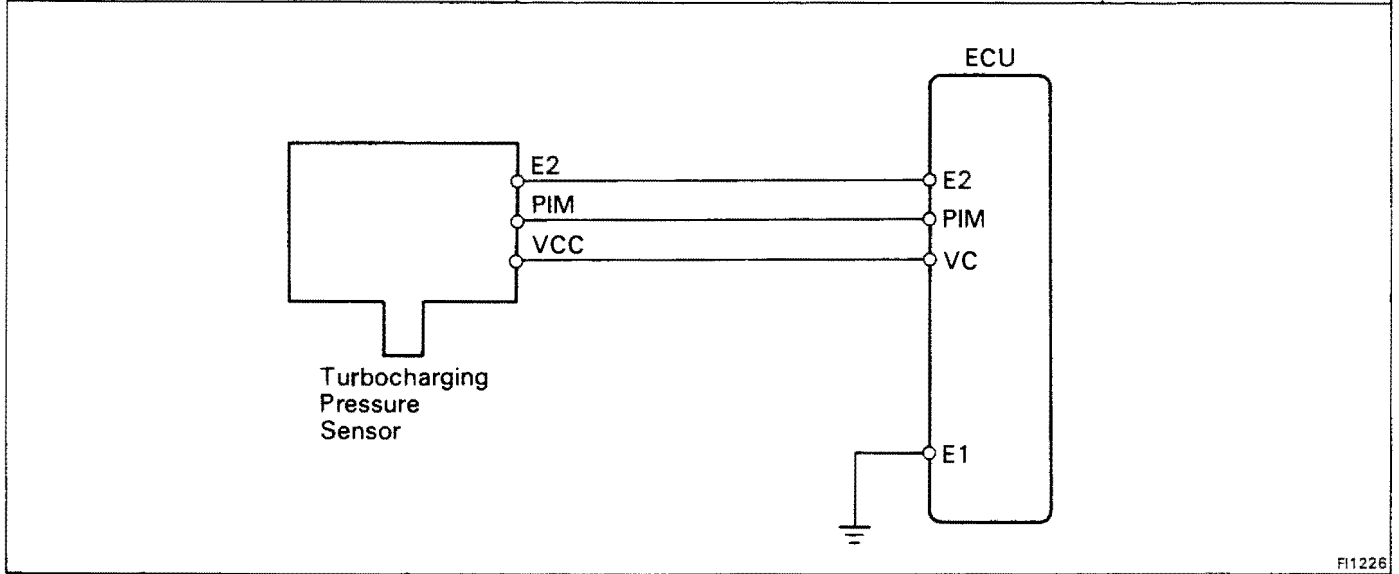

FI1226

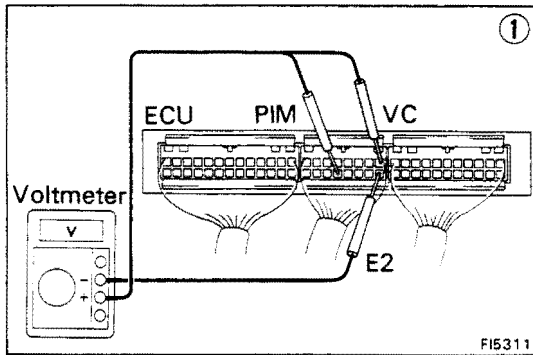

FI5311

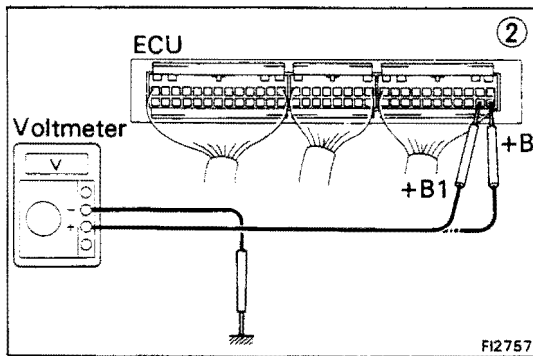

FI2757

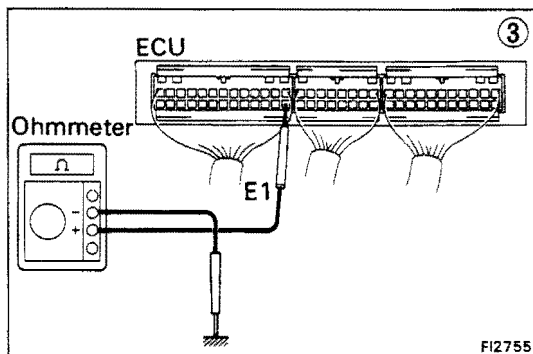

FI2755

```

    graph TD
      Step1["① There is no voltage between ECU terminals PIM or VC and E2. (IG SW ON)"]
      Step2["② Check that there is voltage between ECU terminal +B or +B1 and body ground. (IG SW ON)"]
      Step3["③ Check wiring between ECU terminal E1 and body ground."]
      
      Step1 --> Step2
      Step2 -- OK --> Step3
      Step2 -- NO --> Ref["Refer to +B - E1 trouble section (No.1). (See page FI-88)"]
      
      Step3 -- OK --> CheckSensor["Check turbocharging pressure sensor. (See page FI-198)"]
      Step3 -- BAD --> Repair1["Repair or replace."]
      
      CheckSensor -- BAD --> ReplaceSensor["Replace turbocharging pressure sensor."]
      CheckSensor -- OK --> CheckWiring2["Check wiring between ECU and vacuum sensor."]
      
      CheckWiring2 -- OK --> TryECU["Try another ECU."]
      CheckWiring2 -- BAD --> Repair2["Repair or replace."]
    
```



No.	Terminals	Trouble	Condition	STD Voltage
13	AC1 – E1	No voltage	Air conditioning ON	8 – 14 V

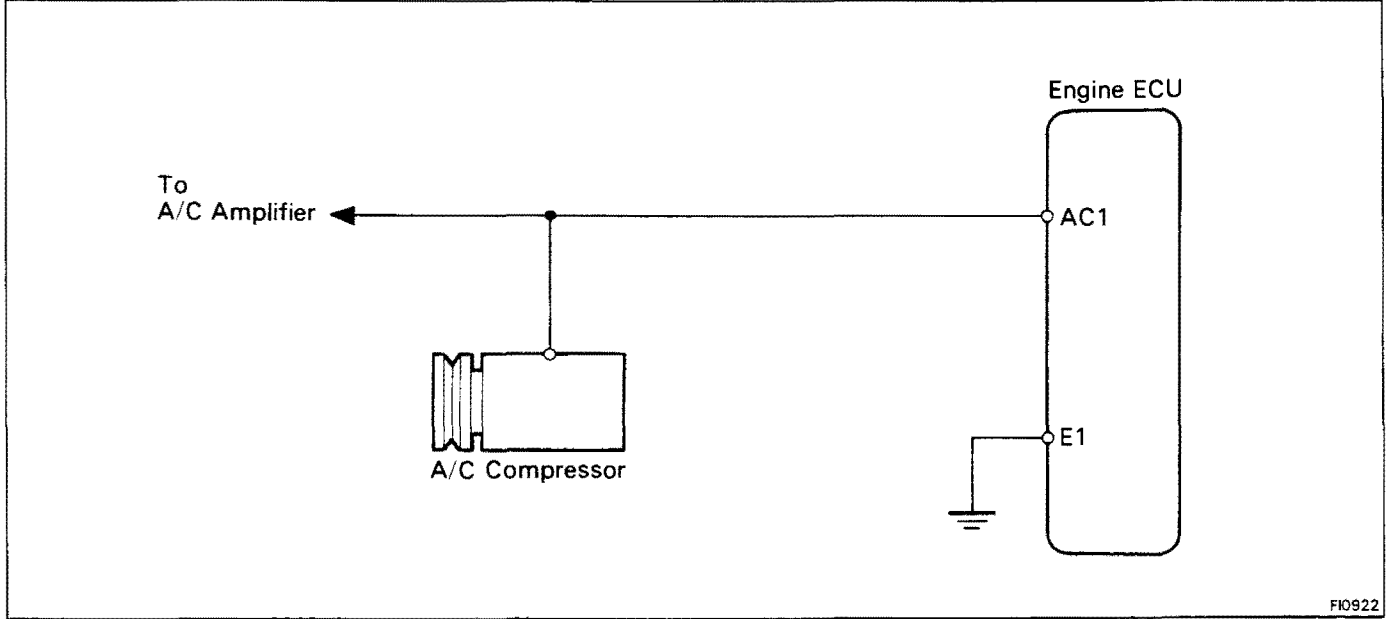

FI0922

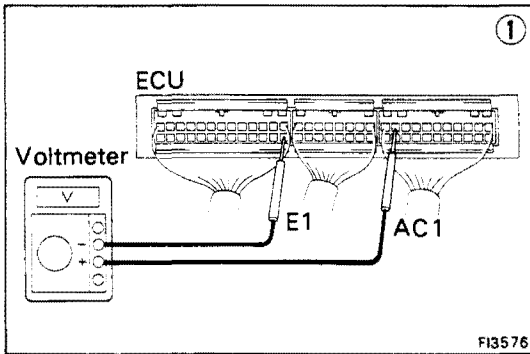

FI3576

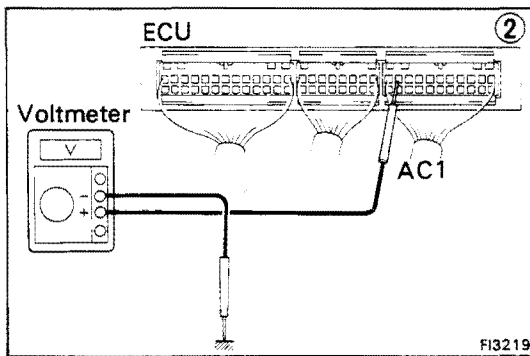

FI3219

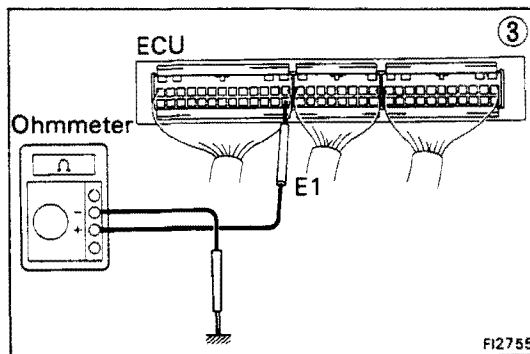

FI2755

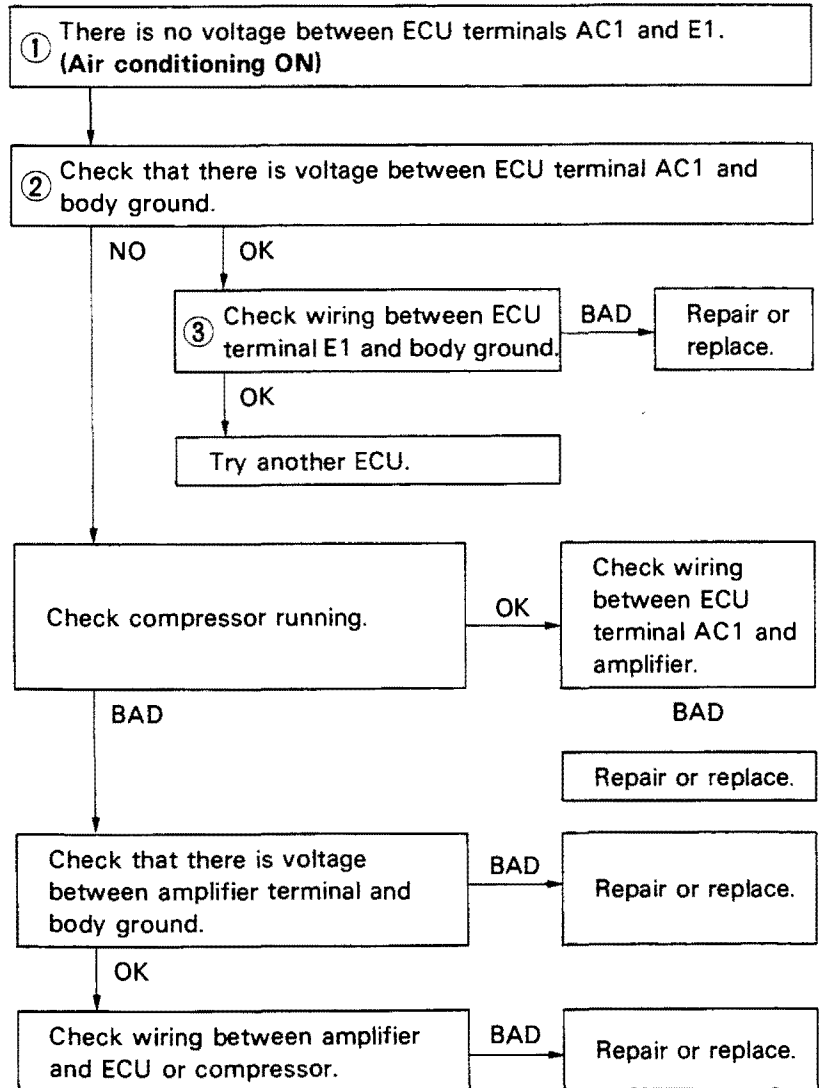

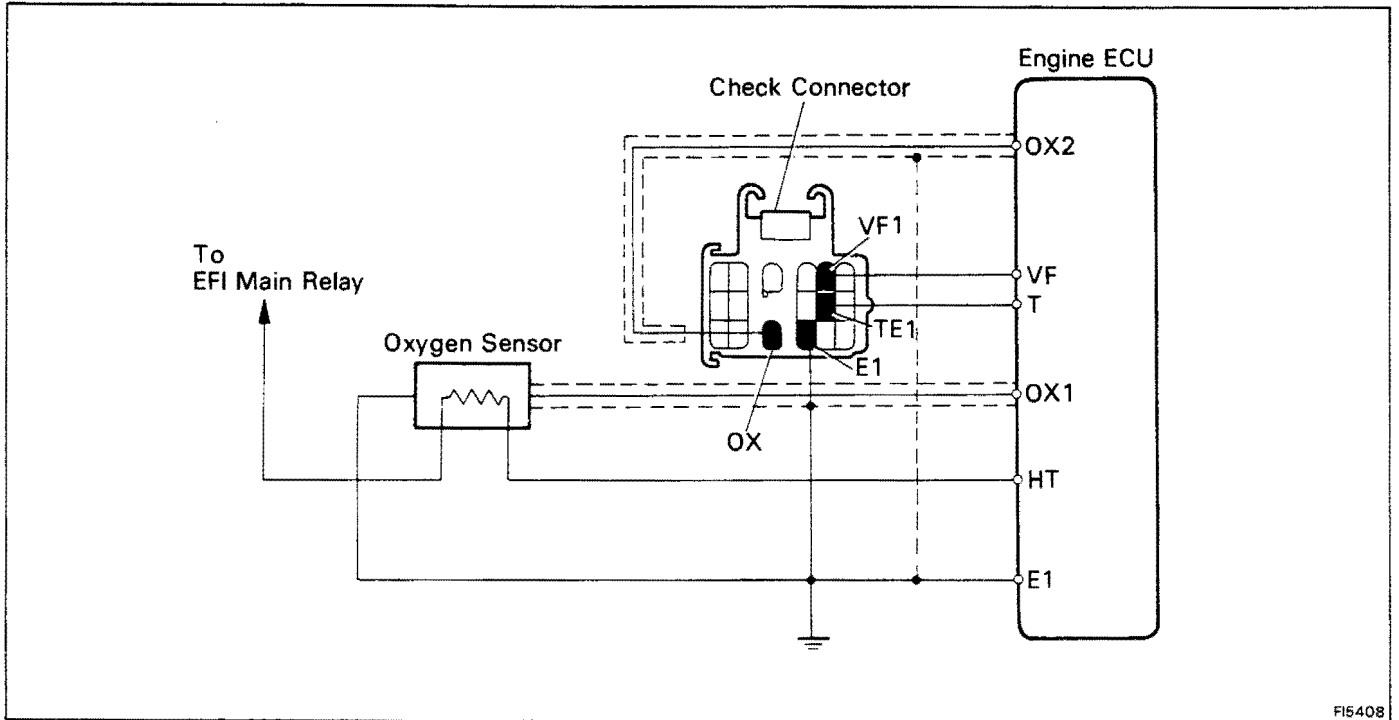

FI5408

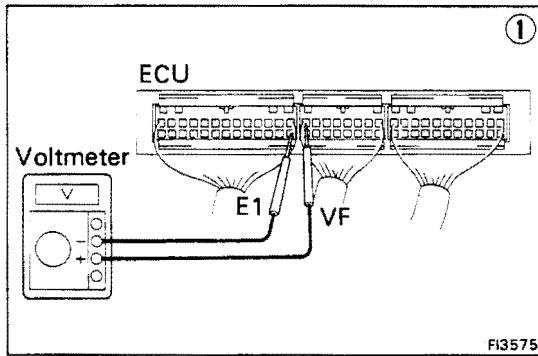

FI3575

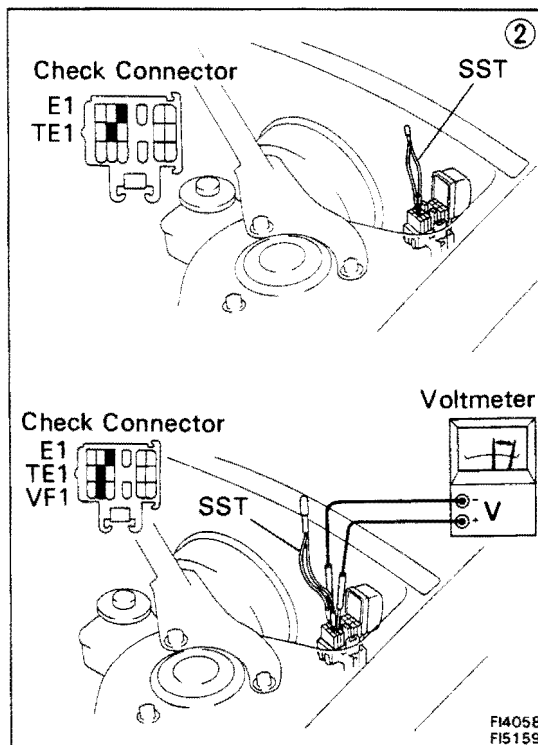

FI4058  
FI5159

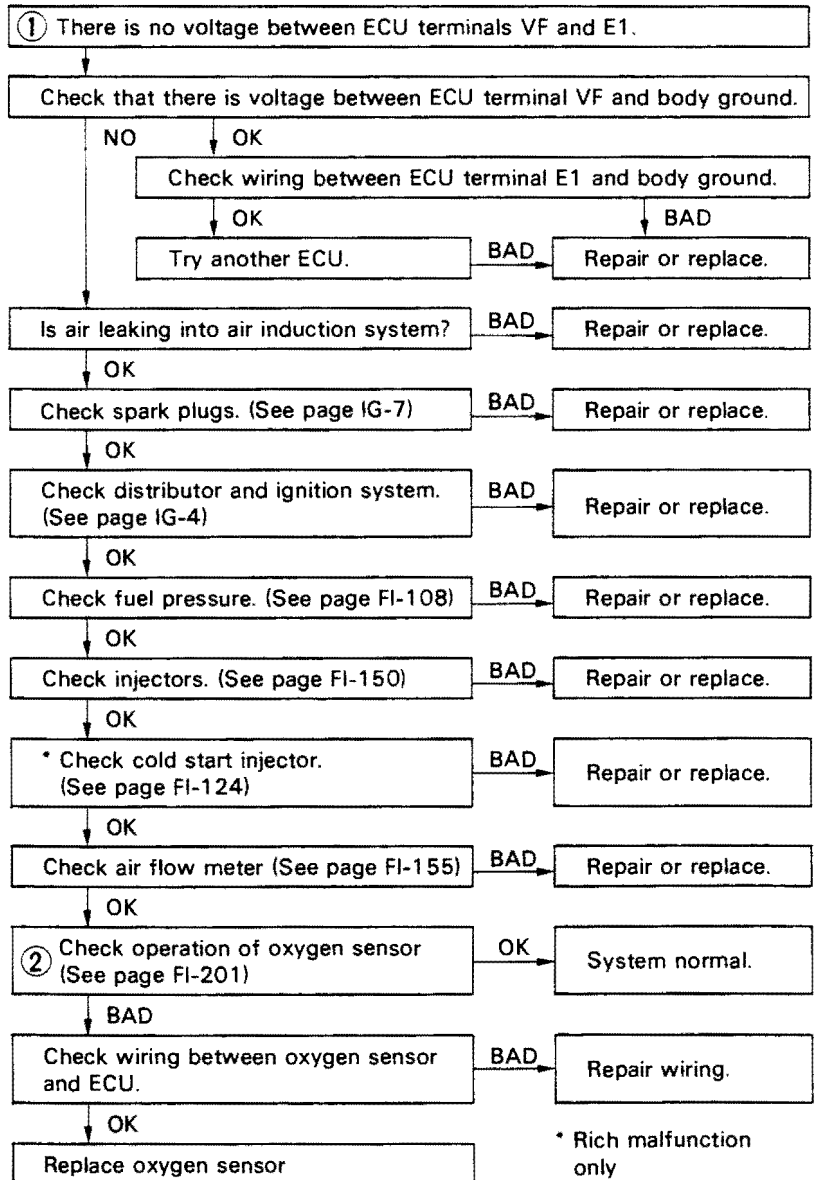

\* Rich malfunction only

# FUEL SYSTEM

## Fuel Pump

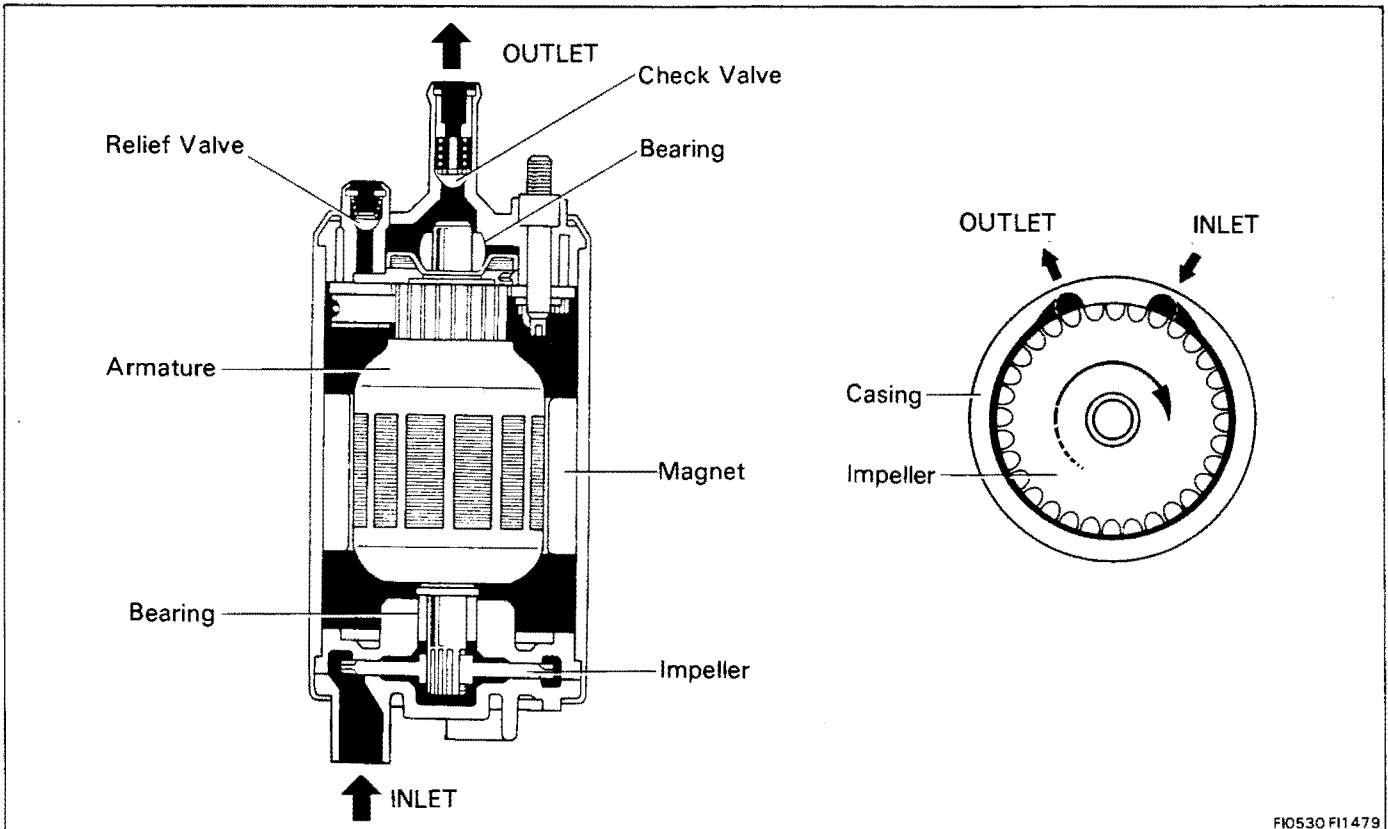

FI0530 FI1479

### 5S-FE and 3S-GE

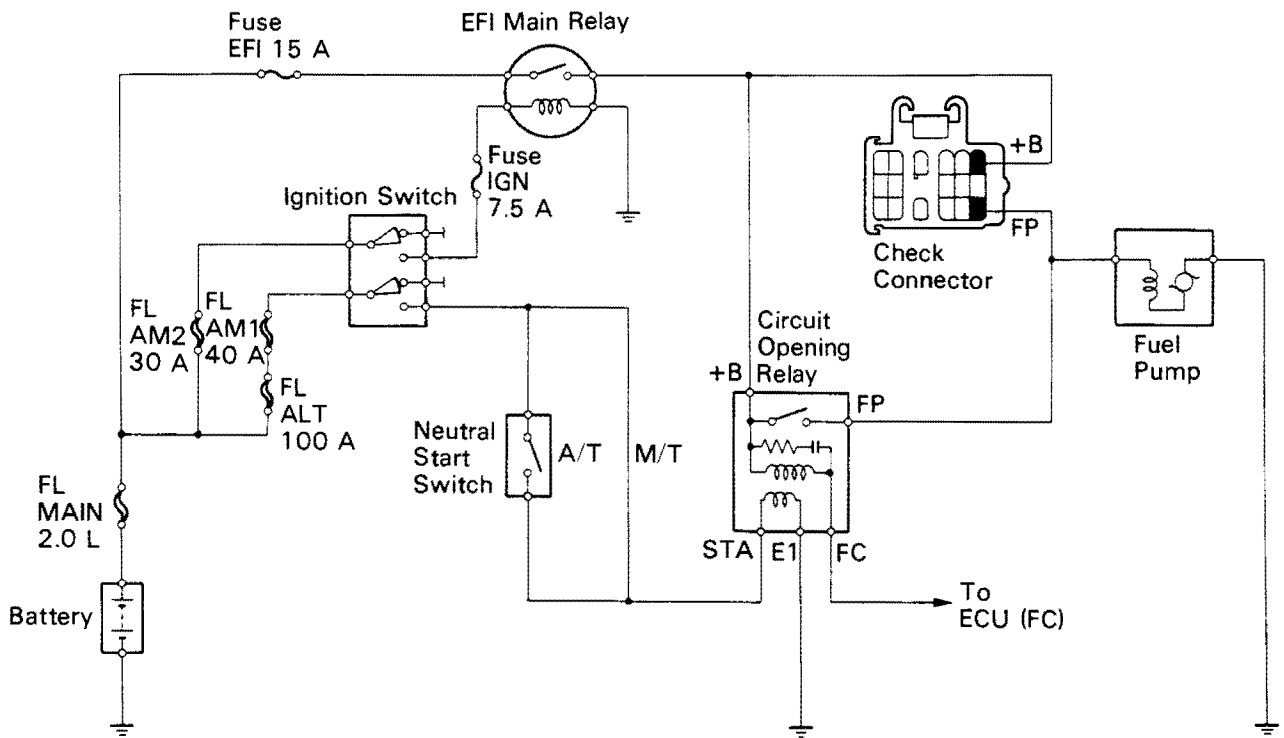

FI5367

3S-GTE

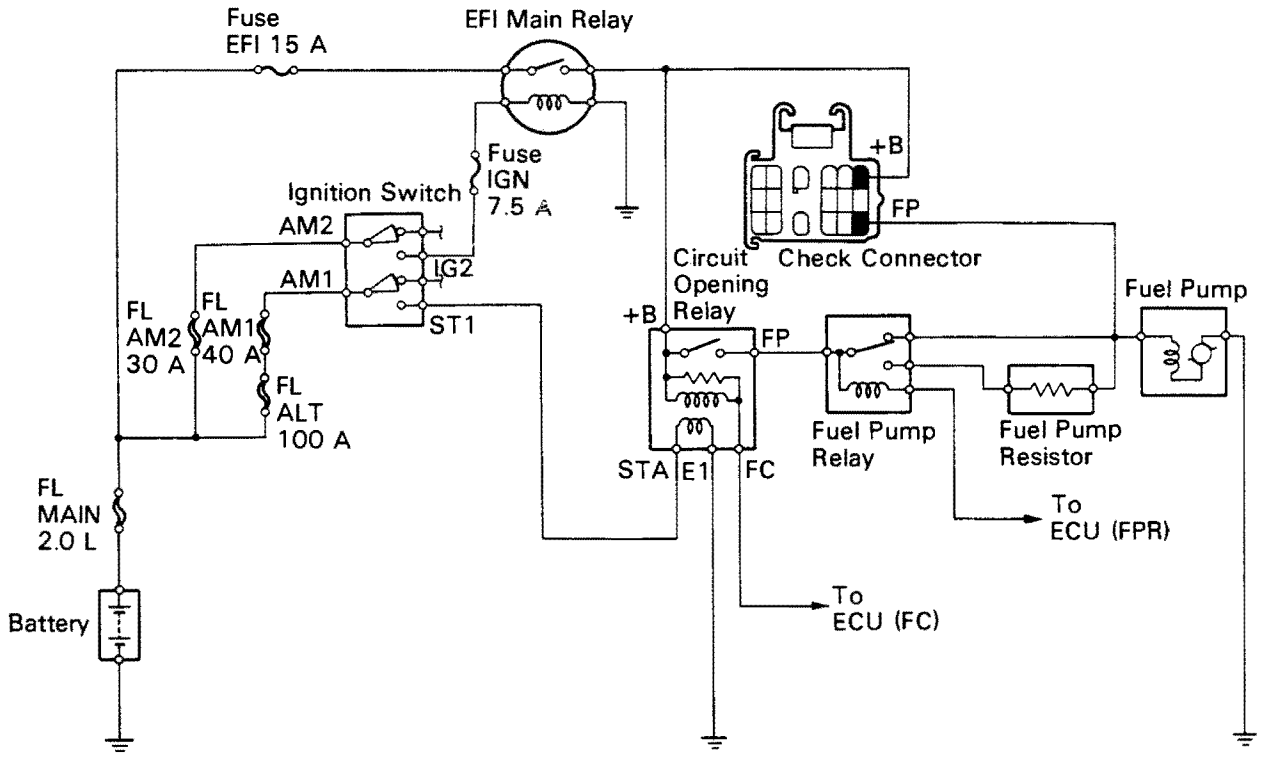

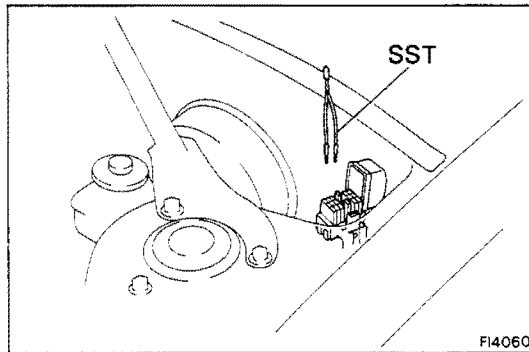
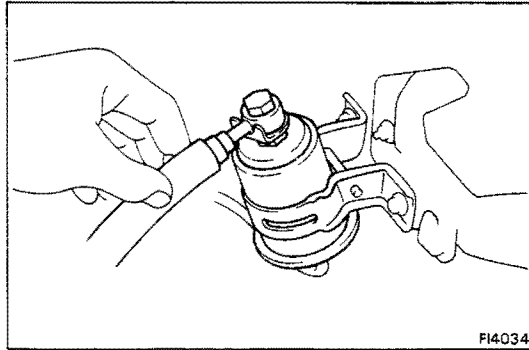
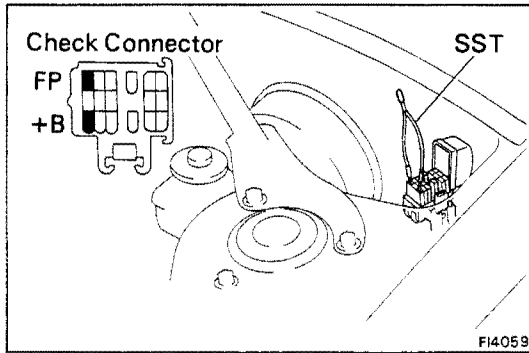

## ON-VEHICLE INSPECTION (5S-FE)

### 1. CHECK FUEL PUMP OPERATION

- (a) Using SST, connect terminals +B and FP of the check connector.

SST 09843-18020

- (b) Turn the ignition switch ON.

HINT: Do not start the engine.

- (c) Check that there is pressure in the hose from the fuel filter.

HINT: At this time, you will hear fuel return noise.

- (d) Remove SST.

SST 09843-18020

- (e) Turn the ignition switch OFF.

If there is no pressure, check the following parts:

- Fusible links
- Fuses (EFI 15 A, IGN 7.5 A)
- EFI main relay
- Circuit opening relay
- Fuel pump
- Engine ECU
- Wiring connections

### 2. CHECK FUEL PRESSURE

- (a) Check the battery voltage above 12 volts.

- (b) Disconnect the cable from the negative (–) terminal of the battery.

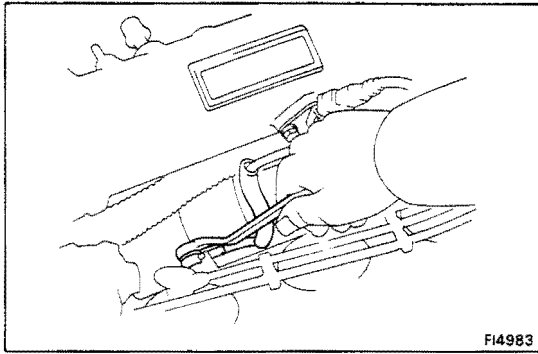

- (c) Put a suitable container or shop towel under the cold start injector pipe.
- (d) Remove the union bolt and two gaskets, and disconnect the cold start injector pipe from the delivery pipe.

HINT: Slowly loosen the union bolt.

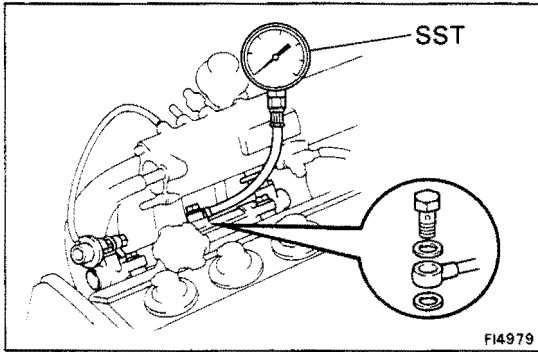

- (e) Install SST (pressure gauge) to the delivery pipe with two new gaskets and the union bolt.

SST 09268-45012

**Torque: 180 kg-cm (13 ft-lb, 18 N·m)**

- (f) Wipe off any splattered gasoline.
- (g) Disconnect the cold start injector connector.
- (h) Reconnect the battery negative (-) cable.

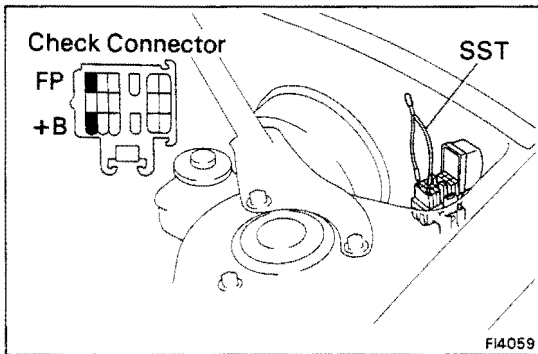

- (i) Using SST, connect terminals +B and FP of the check connector.

SST 09843-18020

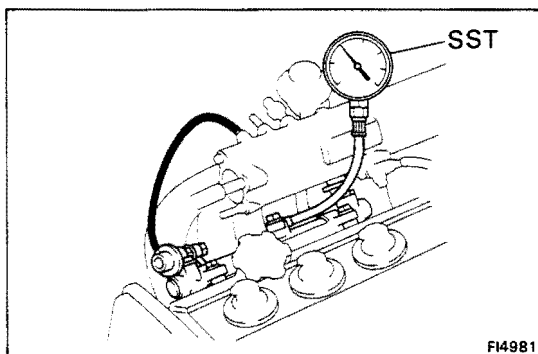

- (j) Turn the ignition switch ON.

- (k) Measure the fuel pressure.

**Fuel pressure: 2.7 – 3.1 kg/cm<sup>2</sup>  
(38 – 44 psi, 265 – 304 kPa)**

If pressure is high, replace the fuel pressure regulator.

If pressure is low, check the following parts:

- Fuel hoses and connection
- Fuel pump
- Fuel filter
- Fuel pressure regulator

- (l) Remove SST.

SST 09843-18020

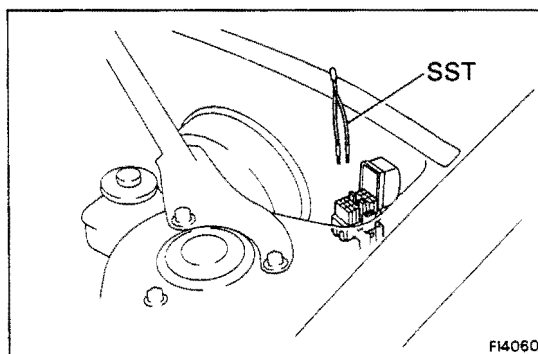

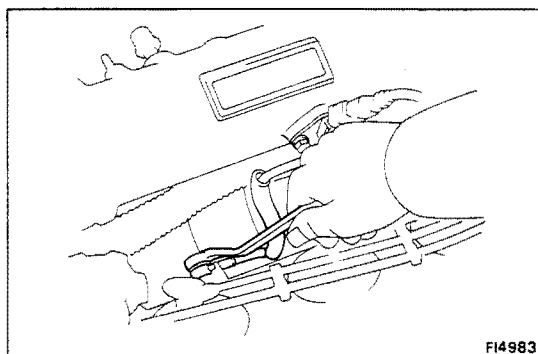
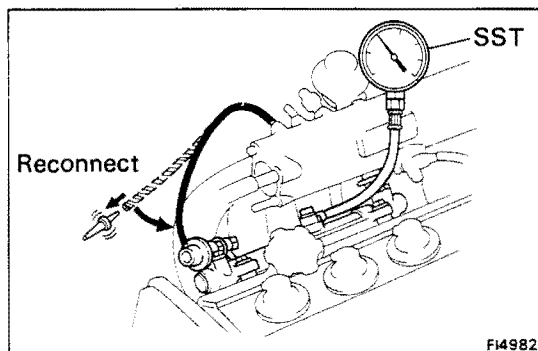
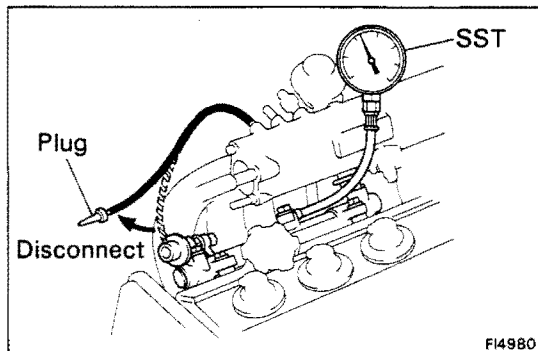

- (m) Start the engine.
- (n) Disconnect the vacuum sensing hose from the fuel pressure regulator.
- (o) Measure the fuel pressure at idling.

**Fuel pressure: 2.7 – 3.1 kg/cm<sup>2</sup>  
(38 – 44 psi, 265 – 304 kPa)**

- (p) Reconnect the vacuum sensing hose to the fuel pressure regulator and plug the hose end.
- (q) Measure the fuel pressure at idling.

**Fuel pressure: 2.1 – 2.6 kg/cm<sup>2</sup>  
(30 – 37 psi, 226 – 255 kPa)**

If pressure is not as specified, check the vacuum sensing hose and fuel pressure regulator.

- (r) Stop the engine. Check that the fuel pressure remains 1.5 kg/cm<sup>2</sup> (21 psi, 147 kPa) or more for 5 minutes after the engine is turned off.

If pressure is not as specified, check the fuel pump, pressure regulator and/or injector.

- (s) After checking fuel pressure, disconnect the battery negative (–) cable and carefully remove the SST to prevent gasoline from splashing.

SST 09268-45012

- (t) Reconnect the cold start injector connector.

- (u) Install the cold start injector pipe with two new gaskets and the union bolt.

**Torque: 180 kg-cm (13 ft-lb, 18 N·m)**

- (v) Reconnect the cable to the negative (–) terminal of the battery.
- (w) Check for fuel leakage. (See page FI-11)

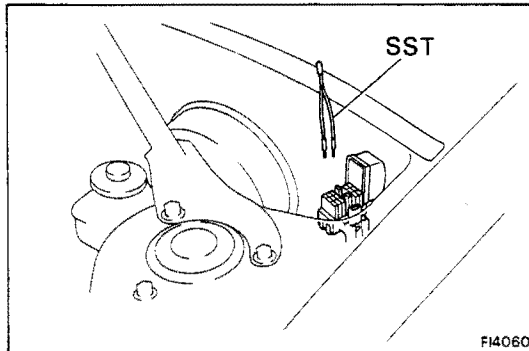
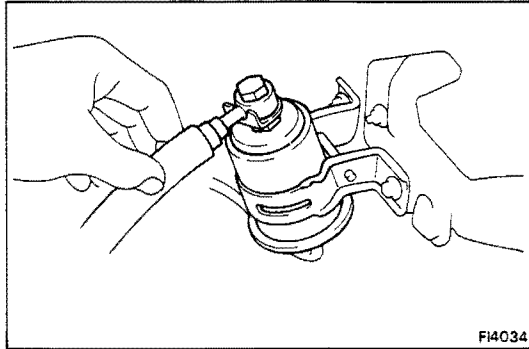
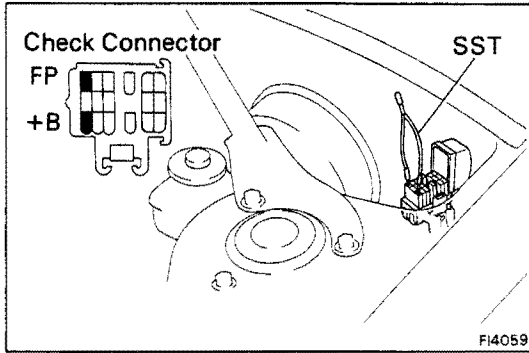

## ON-VEHICLE INSPECTION (3S-GE and 3S-GTE)

### 1. CHECK FUEL PUMP OPERATION

- (a) Using SST, connect terminals +B and FP of the check connector.

SST 09843-18020

- (b) Turn the ignition switch ON.

HINT: Do not start the engine.

- (c) Check that there is pressure in the hose from the fuel filter.

HINT: At this time, you will hear fuel return noise.

- (d) Remove SST.

SST 09843-18020

- (e) Turn the ignition switch OFF.

If there is no pressure, check the following parts:

- Fusible links
- Fuses (EFI 15 A, IGN 7.5 A)
- EFI main relay
- Circuit opening relay
- Fuel pump
- Engine ECU
- Wiring connections

### 2. CHECK FUEL PRESSURE

- (a) Check the battery voltage above 12 volts.

- (b) Disconnect the cable from the negative (–) terminal of the battery.



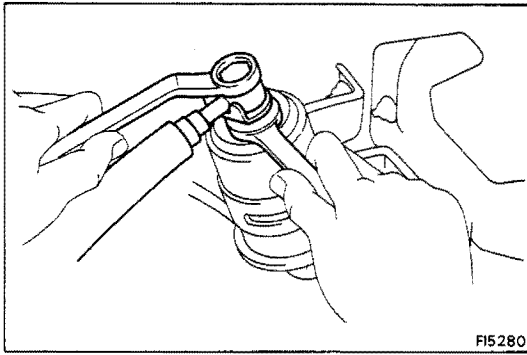

(c) Put a suitable container or shop towel under the fuel filter.

(d) Remove the union bolt and two gaskets, and disconnect the fuel inlet hose from the fuel filter outlet.

HINT: Slowly loosen the union bolt.

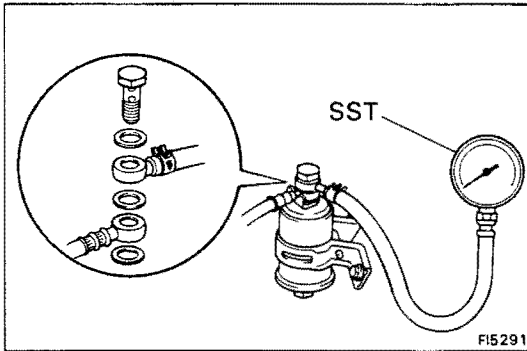

(e) Install the fuel inlet hose and SST (pressure gauge) to the fuel filter outlet with three new gaskets and the union bolt.

SST 09268-45012

Torque: 300 kg-cm (22 ft-lb, 29 N·m)

(f) Wipe off any splattered gasoline.

(g) Reconnect the battery negative (-) cable.

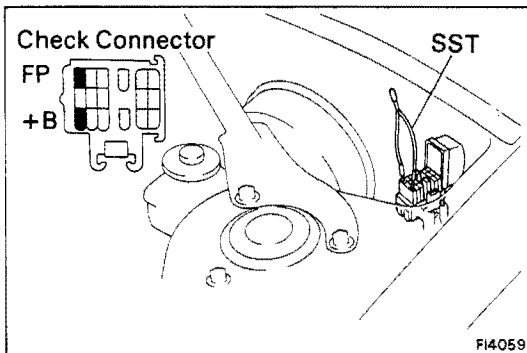

(h) Using SST, connect terminals +B and FP of the check connector.

SST 09843-18020

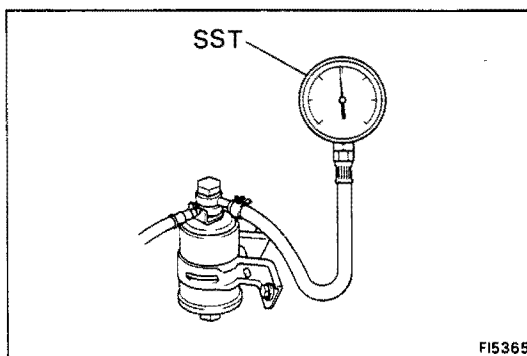

(i) Turn the ignition switch ON.

(j) Measure the fuel pressure.

Fuel pressure:

**3S-GE** 2.7 – 3.1 kg/cm<sup>2</sup>  
(38 – 44 psi, 265 – 304 kPa)

**3S-GTE** 2.3 – 2.7 kg/cm<sup>2</sup>  
(33 – 38 psi, 226 – 265 kPa)

If pressure is high, replace the fuel pressure regulator.

If pressure is low, check the following parts:

- Fuel hoses and connection
- Fuel pump
- Fuel filter
- Fuel pressure regulator

(k) Remove SST.

SST 09843-18020

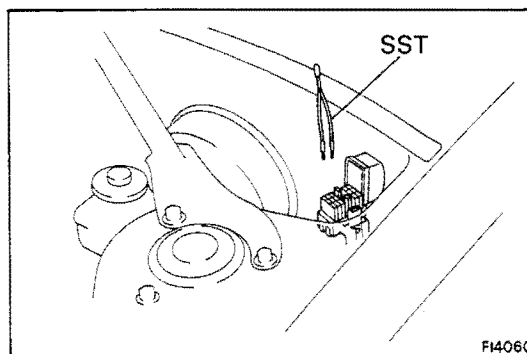

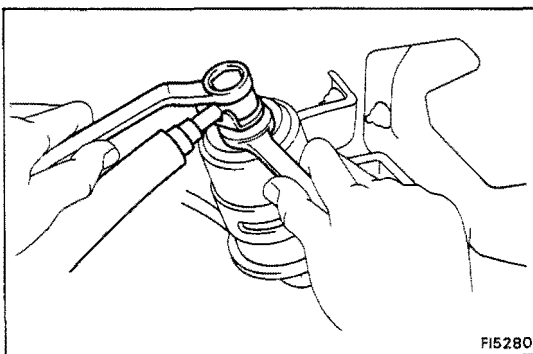
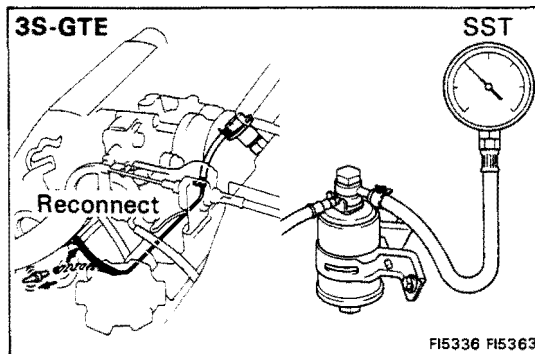
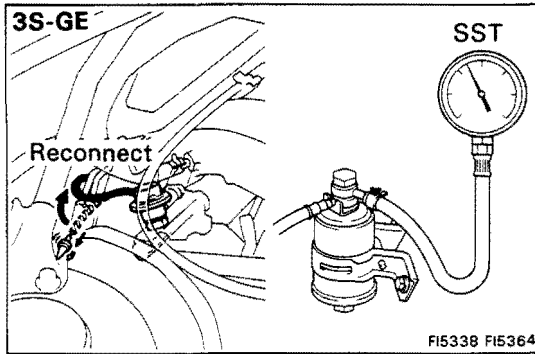
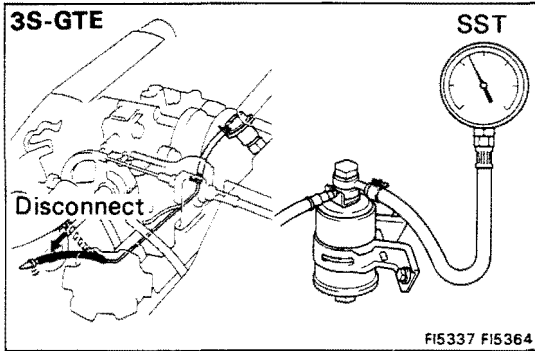
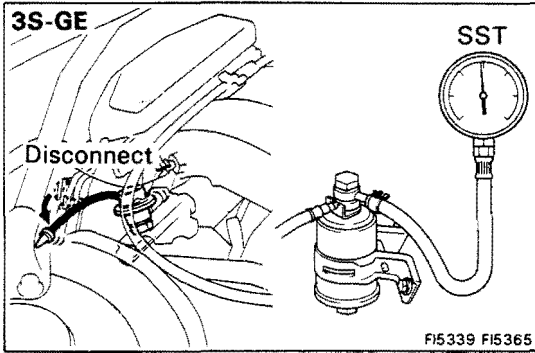

- (l) Start the engine.
- (m) Disconnect the vacuum sensing hose from the fuel pressure regulator.
- (n) Measure the fuel pressure at idling.

**Fuel pressure:**

<b>3S-GE</b>	<b>2.7 – 3.1 kg/cm<sup>2</sup></b> <b>(38 – 44 psi, 265 – 304 kPa)</b>
<b>3S-GTE</b>	<b>2.3 – 2.7 kg/cm<sup>2</sup></b> <b>(33 – 38 psi, 226 – 265 kPa)</b>

- (o) Reconnect the vacuum sensing hose to the fuel pressure regulator and plug the hose end.
- (p) Measure the fuel pressure at idling.

**Fuel pressure:**

<b>3S-GE</b>	<b>2.1 – 2.6 kg/cm<sup>2</sup></b> <b>(30 – 37 psi, 226 – 255 kPa)</b>
<b>3S-GTE</b>	<b>1.9 – 2.2 kg/cm<sup>2</sup></b> <b>(27 – 31 psi, 186 – 216 kPa)</b>

If pressure is not as specified, check the vacuum sensing hose and fuel pressure regulator.

- (q) Stop the engine. Check that the fuel pressure remains 1.5 kg/cm<sup>2</sup> (21 psi, 147 kPa) or more for 5 minutes after the engine is turned off.

If pressure is not as specified, check the fuel pump, pressure regulator and/or injector.

- (r) After checking fuel pressure, disconnect the battery negative (–) cable and carefully remove the SST to prevent gasoline from splashing.

SST 09268-45012

- (s) Connect the fuel inlet hose with two new gaskets and the union bolt.

**Torque: 300 kg-cm (22 ft-lb, 29 N·m)**

- (t) Reconnect the cable to the negative (–) terminal of the battery.
- (v) Check for fuel leakage. (See page FI-11)

**REMOVAL OF FUEL PUMP (2WD)**

**CAUTION:** Do not smoke or work near an open flame when working on the fuel pump.

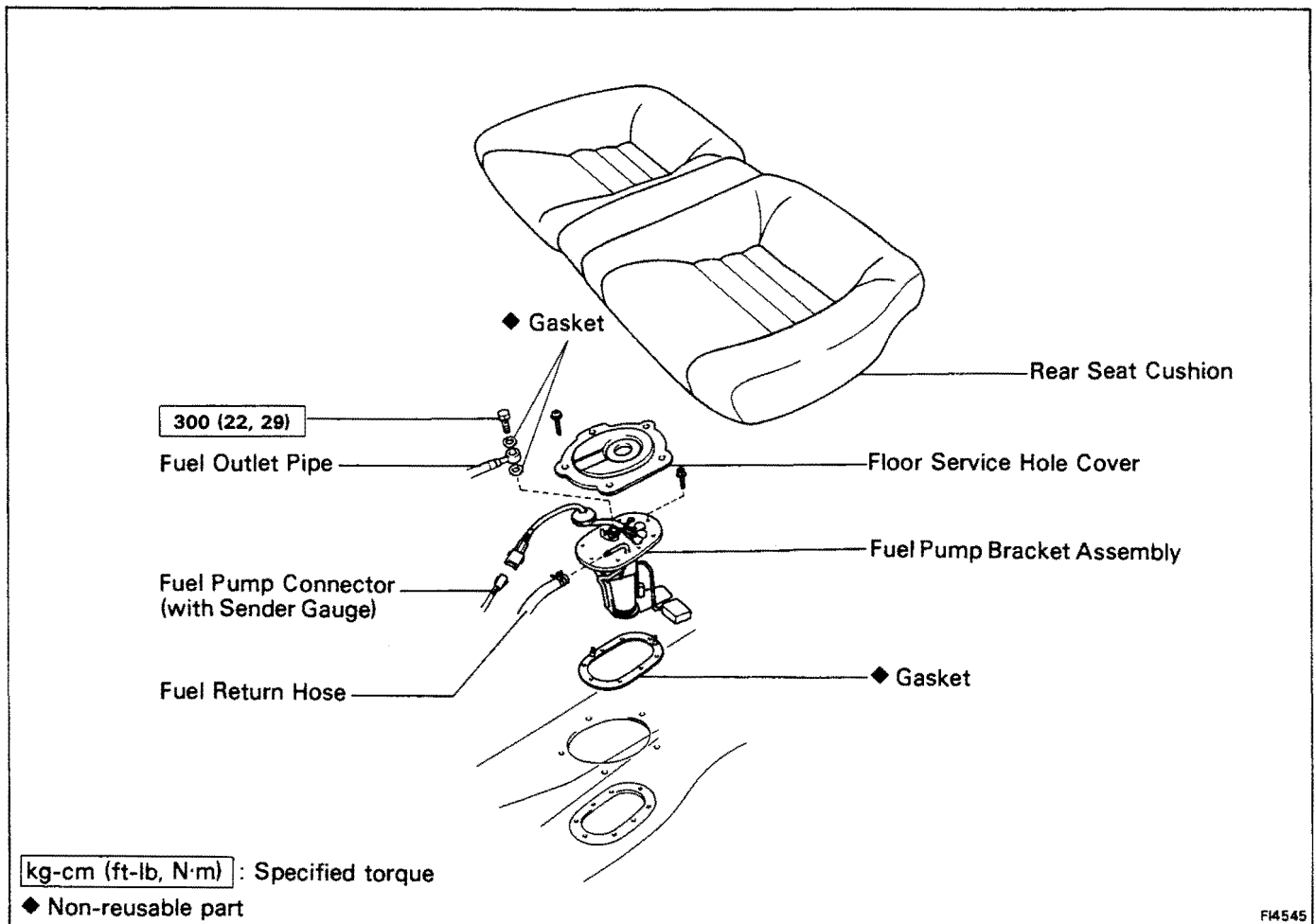

1. **DISCONNECT CABLE FROM NEGATIVE TERMINAL OF BATTERY**
2. **REMOVE REAR SEAT CUSHION**

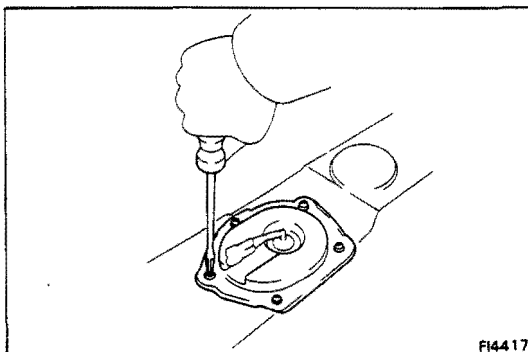

3. **REMOVE FLOOR SERVICE HOLE COVER**
  - (a) Disconnect the fuel pump (with fuel sender gauge) connector.
  - (b) Remove the five screws and service hole cover.

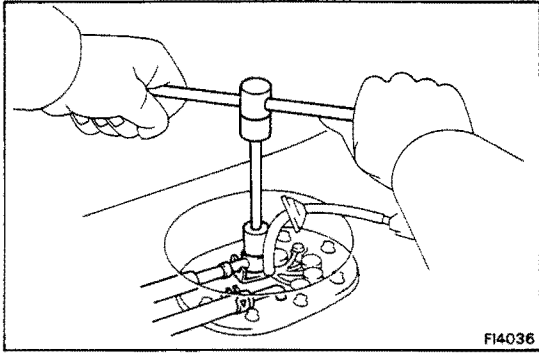

**4. DISCONNECT FUEL PIPE AND HOSE FROM FUEL PUMP BRACKET**

**CAUTION:** Remove the fuel filter cap to prevent the fuel from flowing out.

- (a) Remove the union bolt and two gaskets, and disconnect the outlet pipe from the pump bracket.
- (b) Disconnect the return hose from the pump bracket.

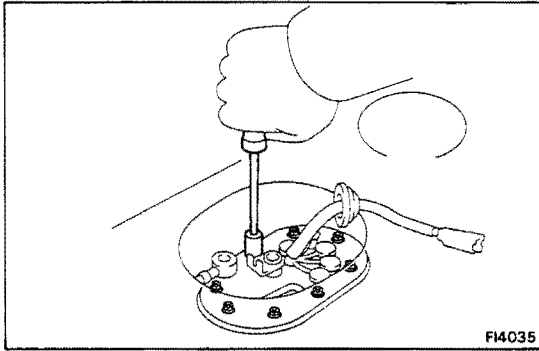

**5. REMOVE FUEL PUMP BRACKET ASSEMBLY FROM FUEL TANK**

- (a) Remove the eight bolts.

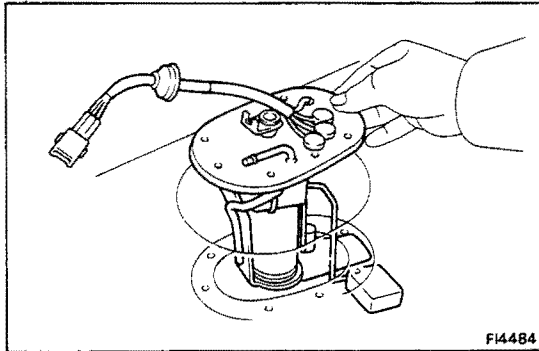

- (b) Pull out the pump bracket assembly.
- (c) Remove the gasket from the pump bracket.

**COMPONENTS**

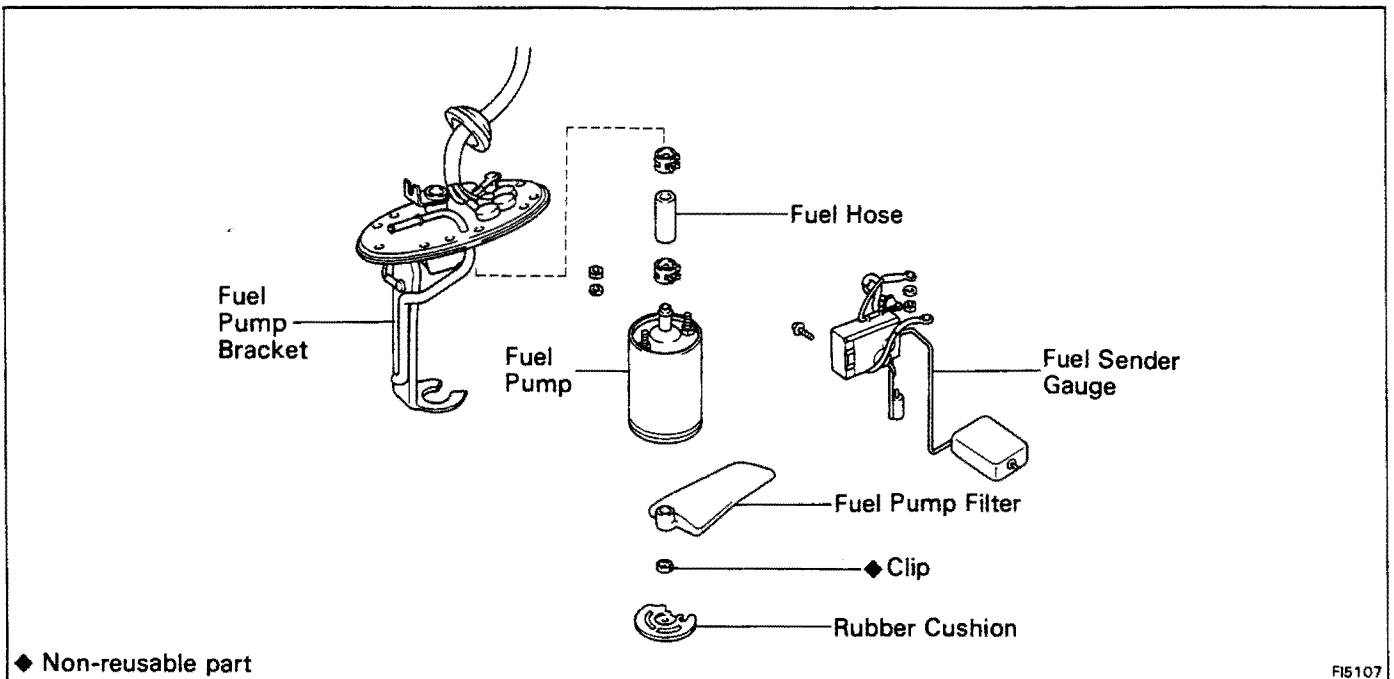

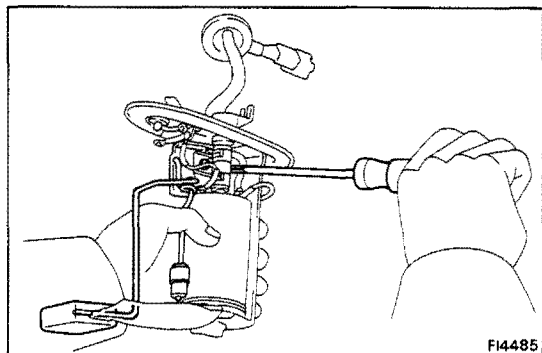

## DISASSEMBLY OF FUEL PUMP

(See page FI-112)

### 1. REMOVE FUEL SENDER GAUGE FROM FUEL PUMP BRACKET

- (a) Remove the nut and spring washer, and disconnect the lead wire from the pump bracket. Disconnect the three lead wires.
- (b) Remove the two screws and sender gauge.

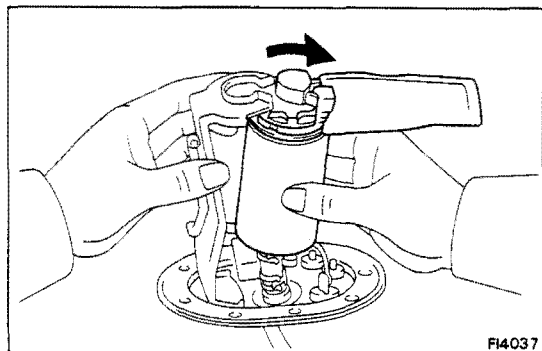

### 2. REMOVE FUEL PUMP FROM FUEL PUMP BRACKET

- (a) Remove the nut and spring washer, and disconnect the lead wire from the fuel pump. Disconnect the two lead wires.
- (b) Pull off the lower side of the fuel pump from the pump bracket.
- (c) Disconnect the fuel hose from the fuel pump, and remove the fuel pump.
- (d) Remove the rubber cushion from the fuel pump.

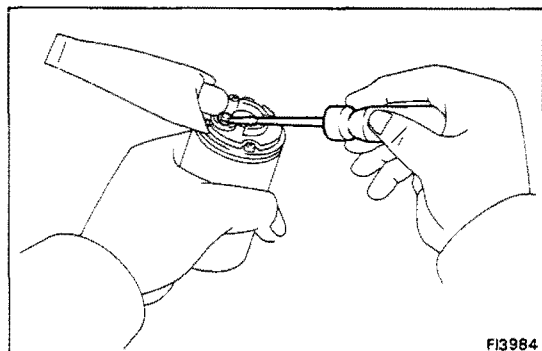

### 3. REMOVE FUEL PUMP FILTER FROM FUEL PUMP

- (a) Using a small screwdriver, remove the clip.
- (b) Pull out the pump filter.

## ASSEMBLY OF FUEL PUMP

(See page FI-112)

### 1. INSTALL FUEL PUMP FILTER TO FUEL PUMP

Install the pump filter with a new clip.

### 2. INSTALL FUEL PUMP TO FUEL PUMP BRACKET

- (a) Install the rubber cushion to the fuel pump.
- (b) Connect the fuel hose to the outlet port of the fuel pump.
- (c) Connect the lead wire to the fuel pump with the spring washer and nut. Connect the two lead wires.
- (d) Install the fuel pump by pushing the lower side of the fuel pump.

### 3. INSTALL FUEL SENDER GAUGE TO FUEL PUMP BRACKET

- (a) Install the sender gauge with the two screws.

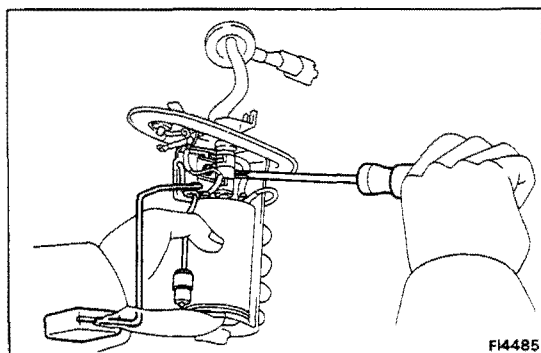

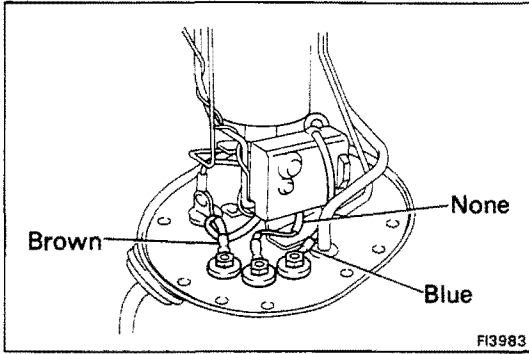

- (b) Connect the lead wire to the pump bracket with the spring washer and nut. Connect the three lead wires as shown.

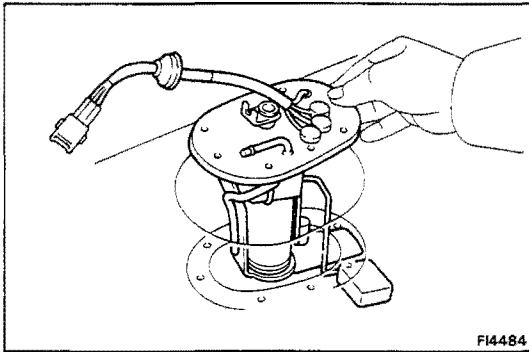

## INSTALLATION OF FUEL PUMP

(See page FI-111)

### 1. INSTALL FUEL PUMP BRACKET ASSEMBLY TO FUEL TANK

- (a) Install a new gasket to the pump bracket.
- (b) Insert the pump bracket assembly into the fuel tank.

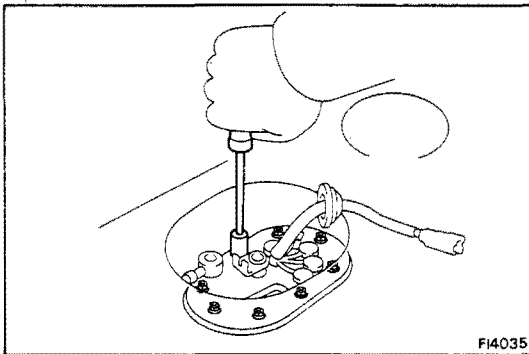

- (c) Install the pump bracket with the eight screws.

**Torque: 40 kg-cm (35 in.-lb, 3.9 N·m)**

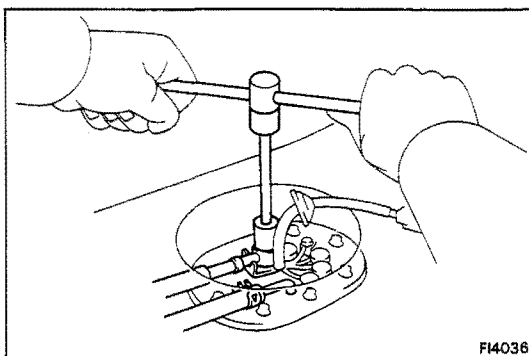

### 2. CONNECT FUEL PIPE AND HOSE TO FUEL PUMP BRACKET

- (a) Connect the outlet pipe to the pump bracket with two new gaskets and the union bolt.

**Torque: 300 kg-cm (22 ft-lb, 29 N·m)**

- (b) Connect the return hose to the pump bracket.

### 3. CHECK FOR FUEL LEAKAGE (See page FI-11)

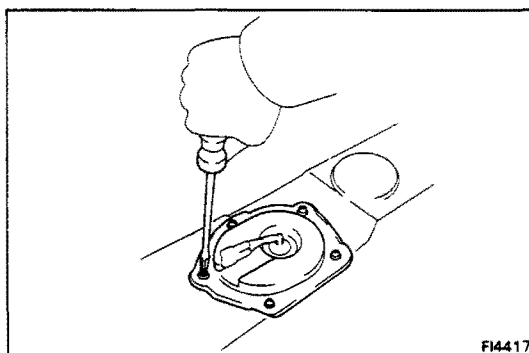

### 4. INSTALL FLOOR SERVICE HOLE COVER

- (a) Install the service hole cover with the five screws.

- (b) Connect the fuel pump (with fuel sender gauge) connector.

### 5. INSTALL REAR SEAT CUSHION

### 6. CONNECT CABLE TO NEGATIVE TERMINAL OF BATTERY

### REMOVAL OF FUEL PUMP (4WD)

**CAUTION:** Do not smoke or work near an open flame when working on the fuel pump.

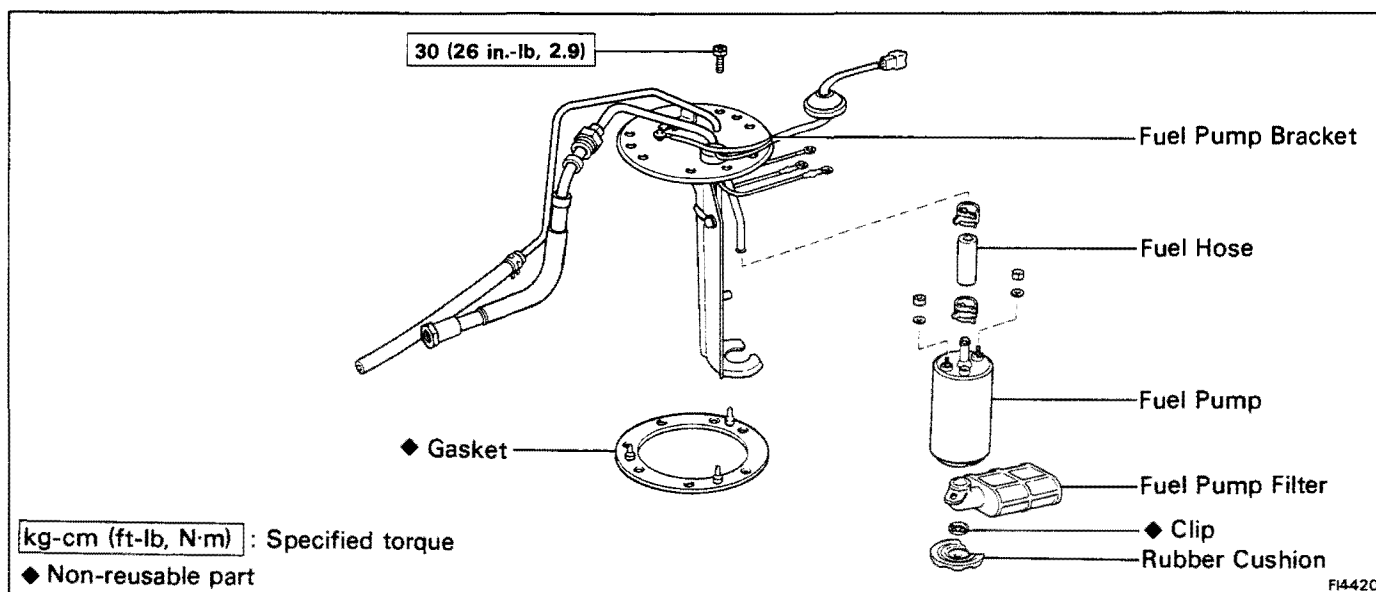

1. DISCONNECT CABLE FROM NEGATIVE TERMINAL OF BATTERY
2. REMOVE FUEL TANK

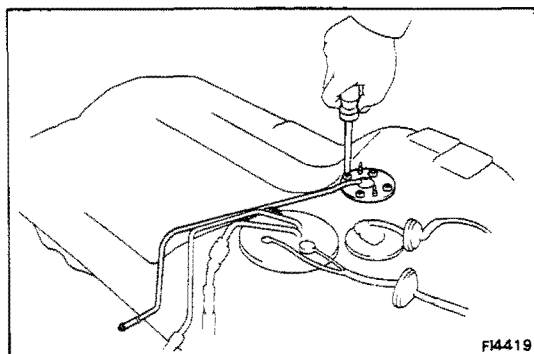

3. REMOVE FUEL EVAPORATION BENT TUBE
  - (a) Remove the bolt holding the bent tube to the fuel pump bracket.
  - (b) Remove the four screws, bent tube and gasket.

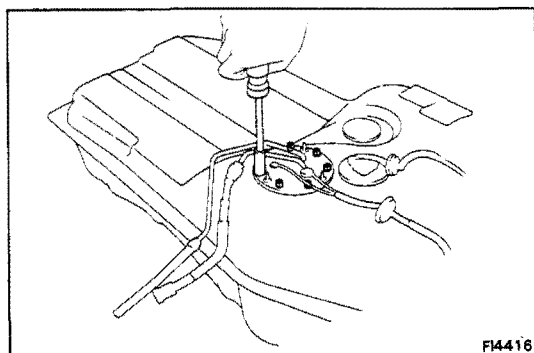

4. REMOVE FUEL PUMP BRACKET ASSEMBLY FROM FUEL TANK
  - (a) Remove the six bolts.

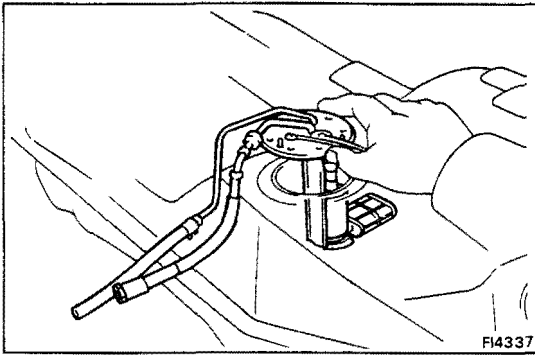

- (b) Pull out the pump bracket assembly.
- (c) Remove the gasket from the pump bracket.

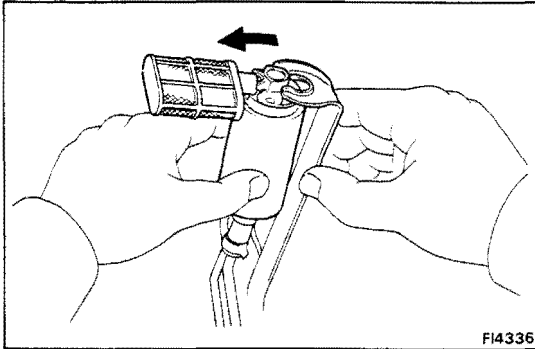

- 5. REMOVE FUEL PUMP FROM FUEL PUMP BRACKET**
- (a) Pull out the lower side of the fuel pump from the bracket.
  - (b) Remove the rubber cushion from the fuel pump.
  - (c) Remove the nut and spring washer, and disconnect the lead wire from the fuel pump. Disconnect the three lead wires.
  - (d) Disconnect the fuel hose from the fuel pump, and remove the fuel pump.

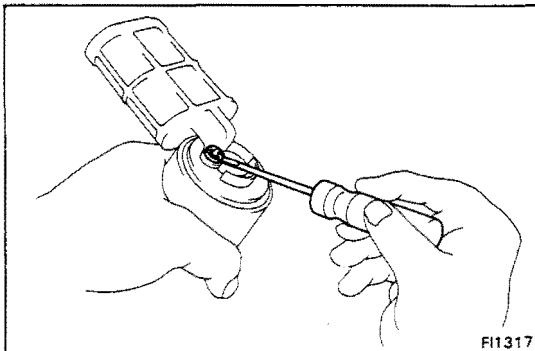

- 6. REMOVE FUEL PUMP FILTER FROM FUEL PUMP**
- (a) Using a small screwdriver, remove the clip.
  - (b) Pull out the pump filter.

**INSTALLATION OF FUEL PUMP**

(See page FI-115)

- 1. INSTALL FUEL PUMP FILTER TO FUEL PUMP**  
Install the pump filter with a new clip.
- 2. INSTALL FUEL PUMP TO FUEL PUMP BRACKET**
- (a) Connect the fuel hose to the outlet port of the fuel pump.
  - (b) Connect the lead wire to the fuel pump with the spring washer and nut. Connect the three lead wires.
  - (c) Install the rubber cushion to the fuel pump.
  - (d) Install the fuel pump by pushing the lower side of the fuel pump.

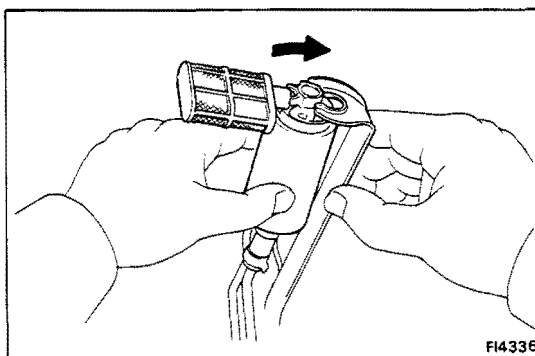



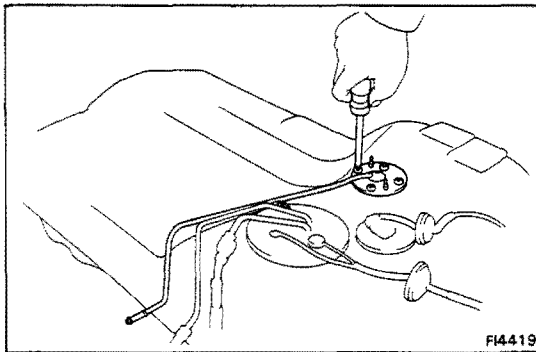
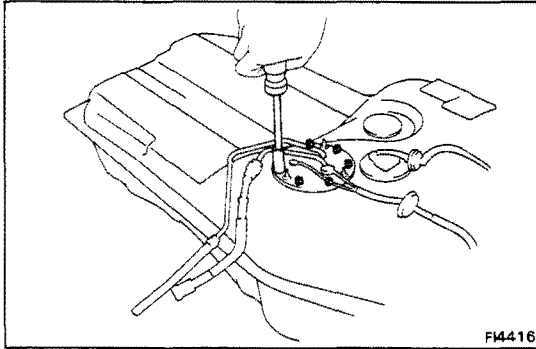
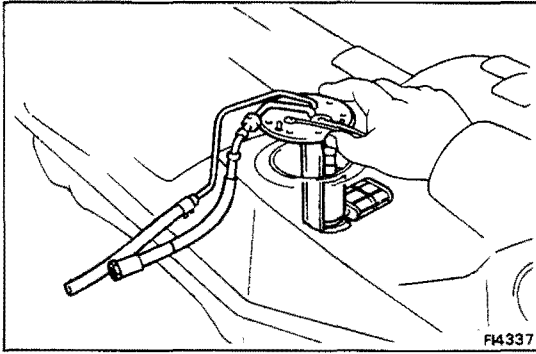

### 3. INSTALL FUEL PUMP BRACKET ASSEMBLY TO FUEL TANK

- (a) Install a new gasket to the pump bracket.
- (b) Insert the pump bracket assembly into the fuel tank.

- (c) Install the pump bracket with the six bolts.

**Torque: 30 kg-cm (26 in.-lb, 2.9 N·m)**

### 4. INSTALL FUEL EVAPORATION BENT TUBE

- (a) Install a new gasket to the bent tube.
- (b) Install the bent tube with the four screws.

**Torque: 15 kg-cm (13 in.-lb, 1.5 N·m)**

- (c) Install the bolt holding the bent tube to the fuel pump bracket.

**Torque: 30 kg-cm (26 in.-lb, 2.9 N·m)**

### 5. INSTALL FUEL TANK

- (a) Apply a thin coat of oil to the flare and tighten the flare nut.
- (b) Then using SST, tighten the nut to the specified torque.

SST 09631-22020

**Torque: 385 kg-cm (28 ft-lb, 38 N·m)**

**HINT:** Use a torque wrench with a fulcrum length of 30 cm (11.81 in.)

#### **NOTICE:**

- Tighten the fuel tank mounting bolts, etc. to the specified torque.
- Tighten the pipe and flare nut type hose to the specified torque.
- Push in the pipe and insert-type hose to the specified position, then install the clip in the specified location.
- If reusing the hose, reinstall the clip at the original location.

### 6. REFILL WITH FUEL

### 7. CONNECT CABLE TO NEGATIVE TERMINAL OF BATTERY

### REMOVAL OF FUEL PUMP

**CAUTION:** Do not smoke or work near an open flame when working on the fuel pump.

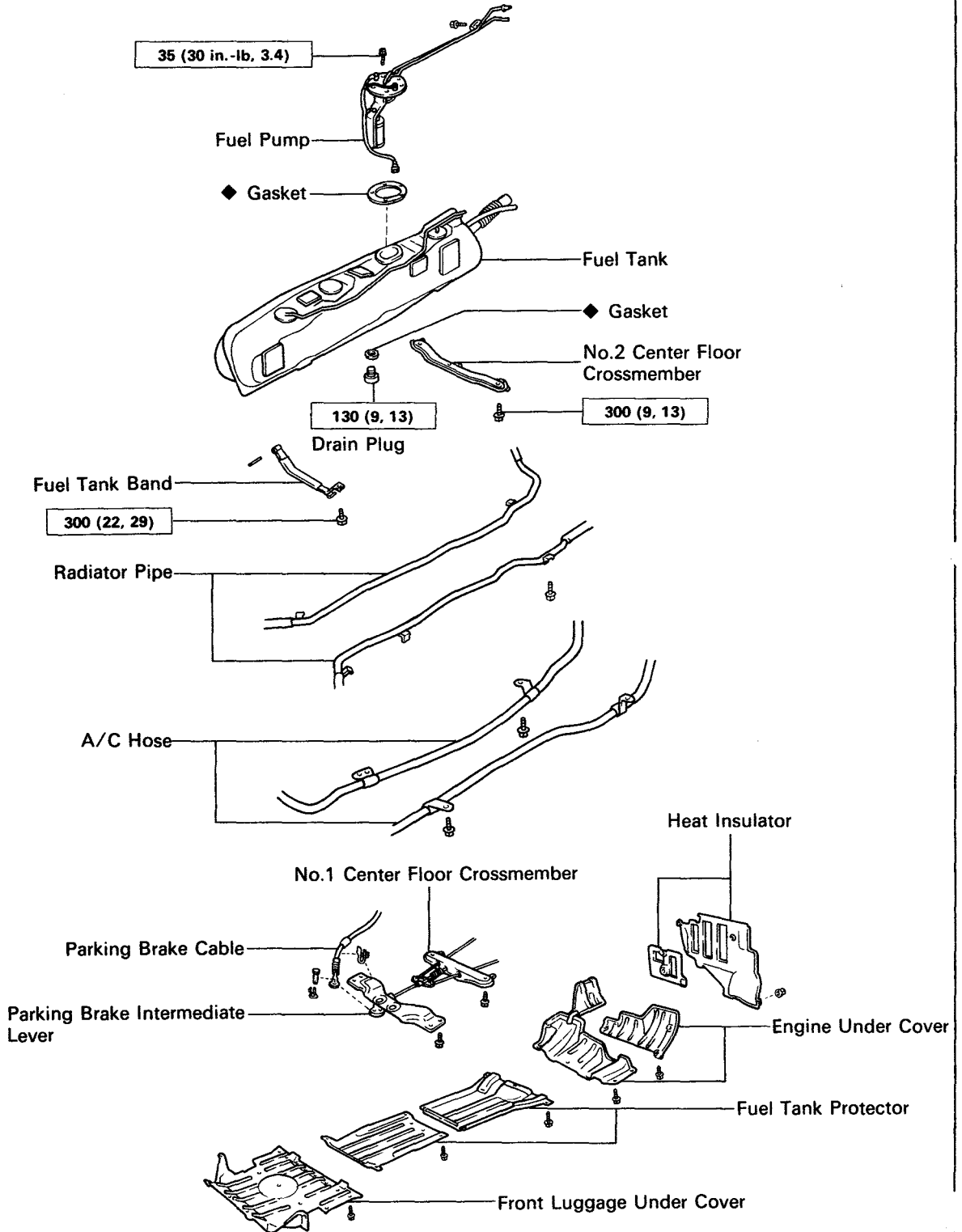

kg-cm (ft-lb, N-m) : Specified Torque

◆ Non-reusable part

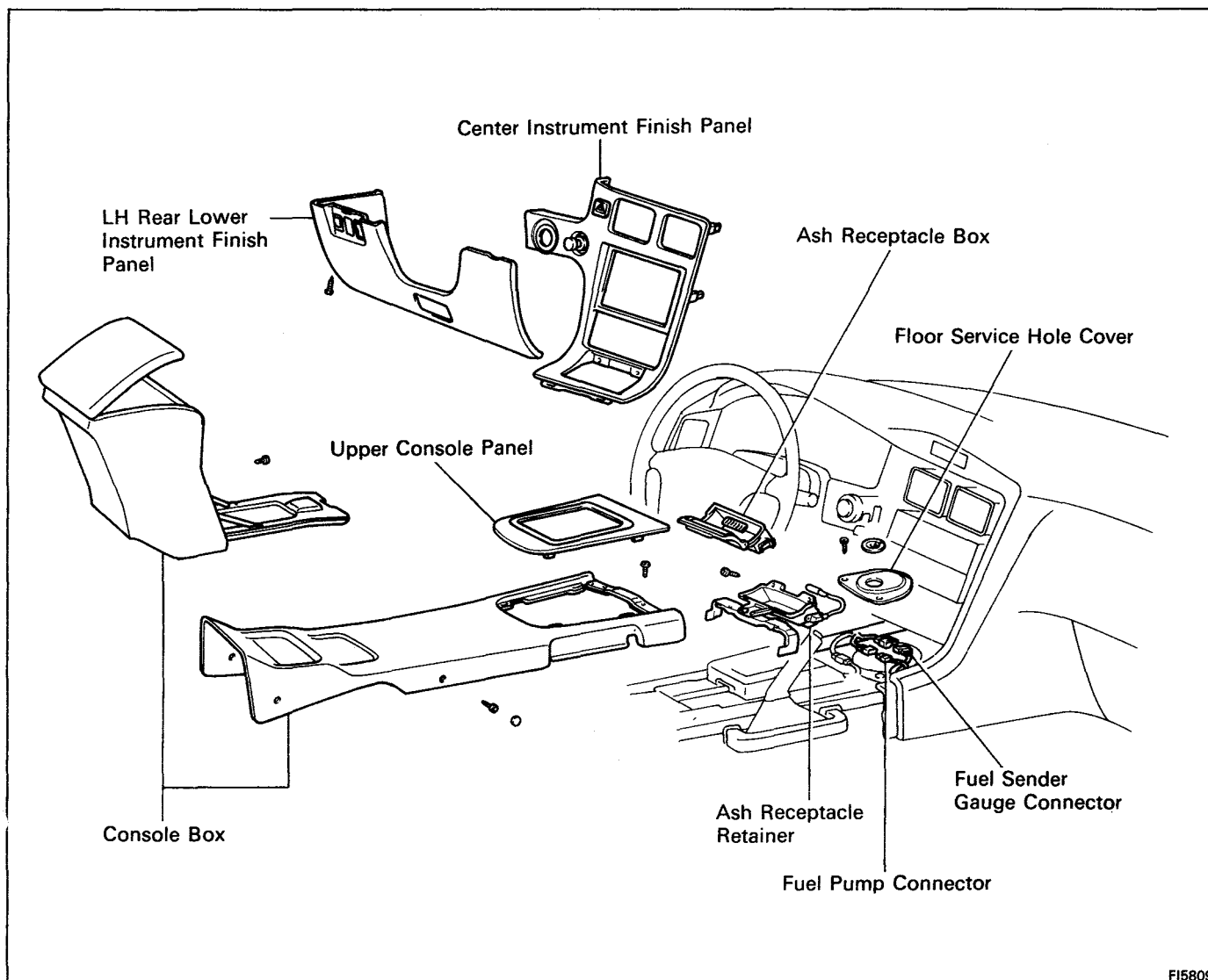

FI5809

**1. DISCONNECT CABLE FROM NEGATIVE TERMINAL OF BATTERY**

**CAUTION:** Work must be started after approx. 20 seconds or longer from the time the ignition switch is turned to the "LOCK" position and the negative (-) terminal cable is disconnected from the battery.

**2. DISCONNECT FUEL PUMP CONNECTOR AND FUEL SENDER GAUGE CONNECTOR**

(a) Remove the following parts:

- Console boxes
- LH lower instrument finish panel
- Center instrument finish panel
- Ash receptacle box
- Ash receptacle retainer

(b) Disconnect the fuel pump connector and fuel sender gauge connector.

(c) Remove the two screws and floor service hole cover.

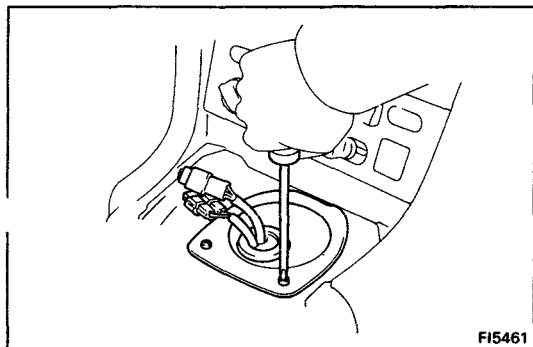

FI5461

3. REMOVE ENGINE UNDER COVERS
4. REMOVE FRONT LUGGAGE UNDER COVER
5. REMOVE FUEL TANK PROTECTORS
6. DRAIN FUEL

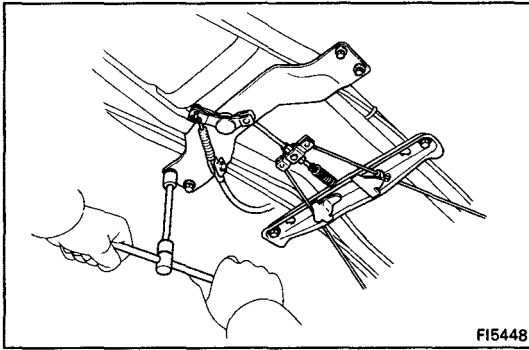

7. REMOVE PARKING BRAKE INTERMEDIATE LEVER AND NO.1 CENTER FLOOR CROSSMEMBER
  - (a) Remove the four bolts and intermediate lever.
  - (b) Remove the two bolts and crossmember.
  - (c) Disconnect the parking brake cable from the intermediate lever.

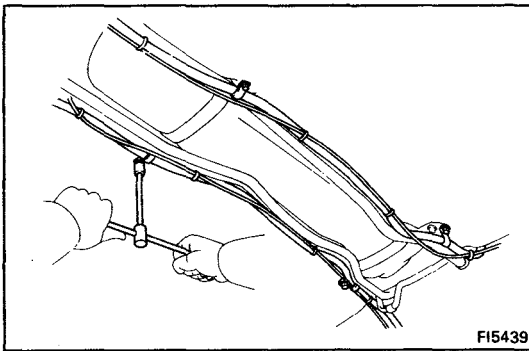

8. DISCONNECT A/C HOSES FROM BODY
 

Remove the four bolts, and disconnect the two A/C hoses from the body.

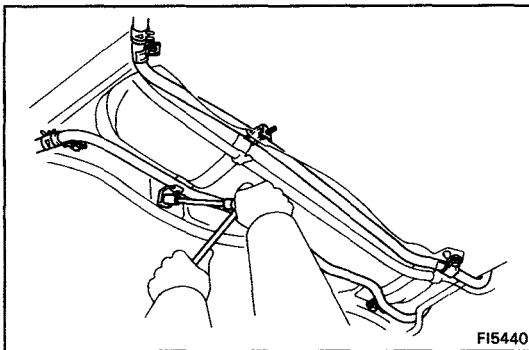

9. DISCONNECT RADIATOR PIPES FROM BODY
 

Remove the six bolts, and disconnect the two radiator pipes from the body.

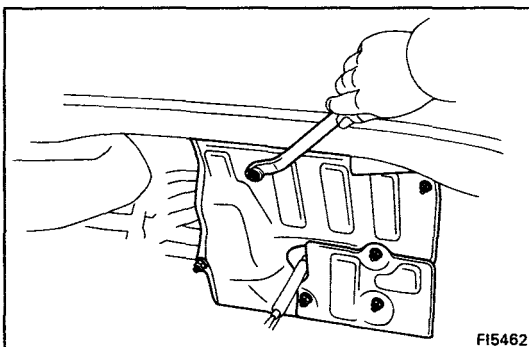

10. REMOVE FUEL TANK HEAT INSULATORS
 

Remove the six nuts and two heat insulators.

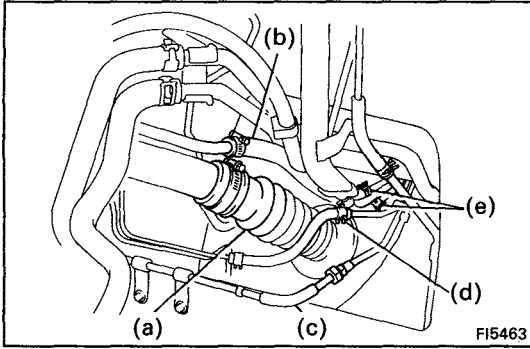

**11. DISCONNECT FUEL HOSES AND TUBE**

**CAUTION:** Remove the fuel filter cap to prevent the fuel from flowing out.

- (a) Fuel inlet hose
- (b) Fuel breather hose
- (c) Fuel pump tube
- (d) Fuel return hose
- (e) Two fuel evaporative bent hoses

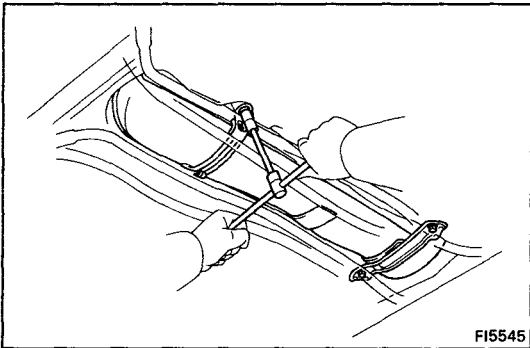

**12. REMOVE FUEL TANK**

- (a) Remove the bolt, pin and tank band.
- (b) Remove the two bolts and No.2 center floor cross-member.
- (c) Remove the fuel tank.

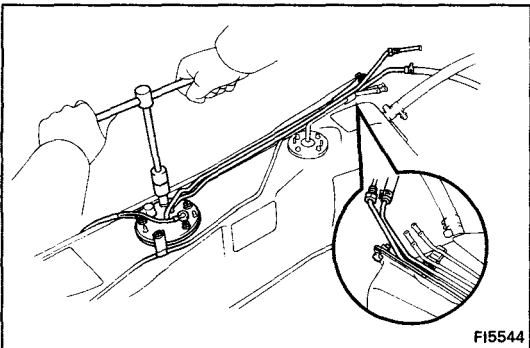

**13. REMOVE FUEL PUMP FROM FUEL TANK**

- (a) Remove the bolt holding the fuel pump tube to the fuel tank.
- (b) Remove the five bolts, and pull out the pump.
- (c) Remove the gasket from the pump bracket.

**COMPONENTS**

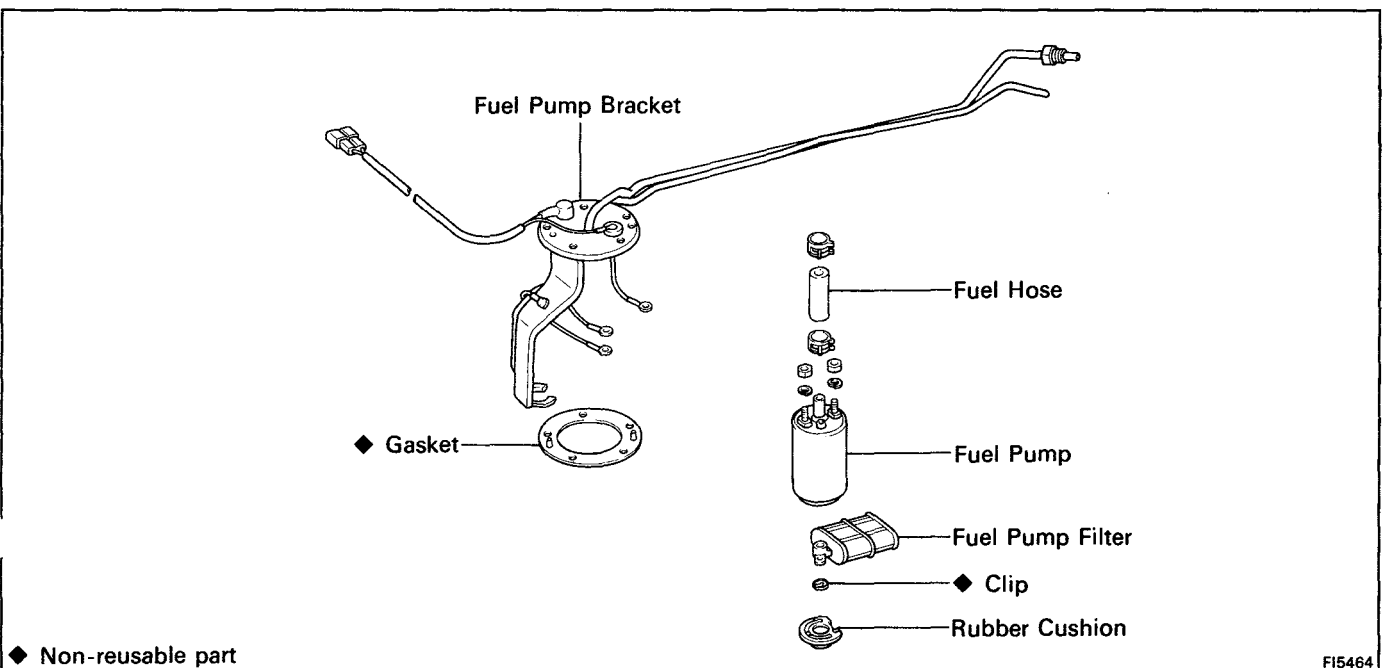

◆ Non-reusable part

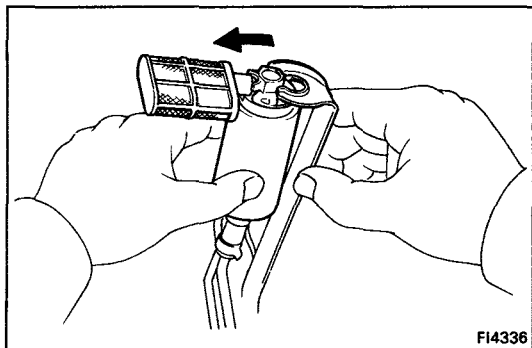

FI4336

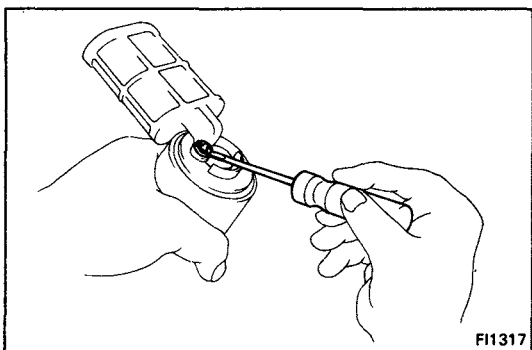

FI1317

## DISASSEMBLY OF FUEL PUMP

(See page FI-95)

1. **REMOVE FUEL PUMP FROM FUEL PUMP BRACKET**
  - (a) Pull out the lower side of the fuel pump from the pump bracket.
  - (b) Remove the rubber cushion from the fuel pump.
  - (c) Remove the nut and spring washers, and disconnect the lead wire from the fuel pump. Disconnect the three lead wires.
  - (d) Disconnect the fuel hose from the fuel pump, and remove the fuel pump.
2. **REMOVE FUEL PUMP FILTER FROM FUEL PUMP**
  - (a) Using a small screwdriver, remove the clip.
  - (b) Pull out the pump filter.

## ASSEMBLY OF FUEL PUMP

(See page FI-95)

1. **INSTALL FUEL PUMP FILTER TO FUEL PUMP**  
Install the pump filter with a new clip.
2. **INSTALL FUEL PUMP TO FUEL PUMP BRACKET**
  - (a) Connect the fuel hose to the outlet port of the fuel pump.
  - (b) Connect the lead wire to the fuel pump with the spring washer and nut. Connect the three lead wires.
  - (c) Install the rubber cushion to the fuel pump.
  - (d) Install the fuel pump by pushing the lower side of the fuel pump.

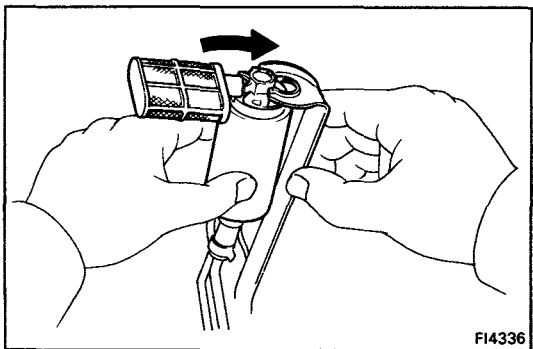

FI4336

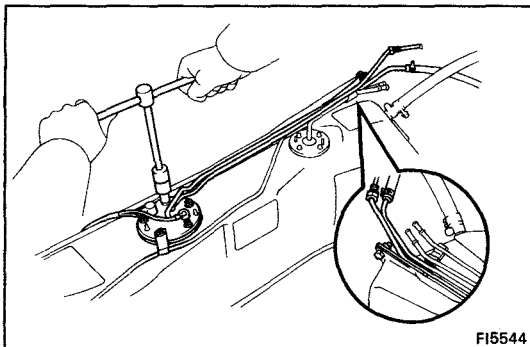

FI5544

## INSTALLATION OF FUEL PUMP

(See pages FI-92 and 93)

### 1. INSTALL FUEL PUMP TO FUEL TANK

- (a) Install a new gasket to the pump bracket.
- (b) Insert the fuel pump bracket into the fuel tank.
- (c) Install the five bolts holding the fuel pump bracket to the fuel tank.

**Torque: 35 kg-cm (35 in.-lb, 3.4 N·m)**

- (d) Install the bolt holding the fuel pump tube to the fuel tank.

### 2. INSTALL FUEL TANK

- (a) Apply soapy water to the cushions on the fuel tank.

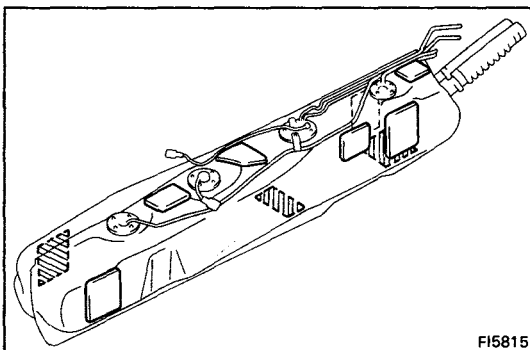

FI5815

- (b) Attach the fuel tank to the body.

- (c) Install the fuel tank band with the pin and bolt.

**Torque: 300 kg-cm (22 ft-lb, 29 N·m)**

- (d) Install the No.2 center floor crossmember with the two bolts.

**Torque: 300 kg-cm (22 ft-lb, 29 N·m)**

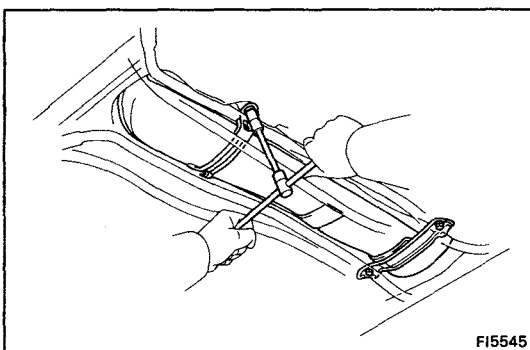

FI5545

### 3. CONNECT FUEL HOSES AND TUBE

- (a) Fuel inlet hose
- (b) Fuel breather hose
- (c) Fuel pump tube
- (d) Fuel return hose
- (e) Two fuel evaporative bent hoses

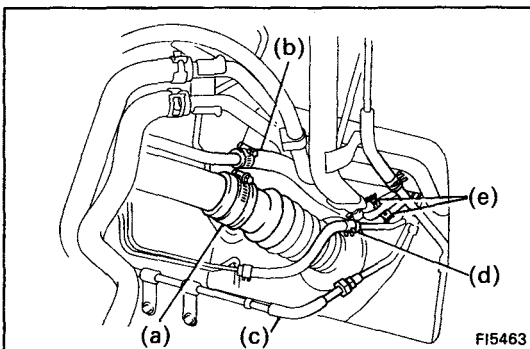

FI5463

### 4. INSTALL RADIATOR PIPES TO BODY

Install the two radiator pipes with the six bolts.

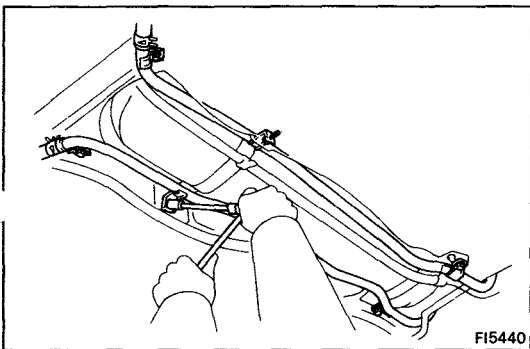

FI5440

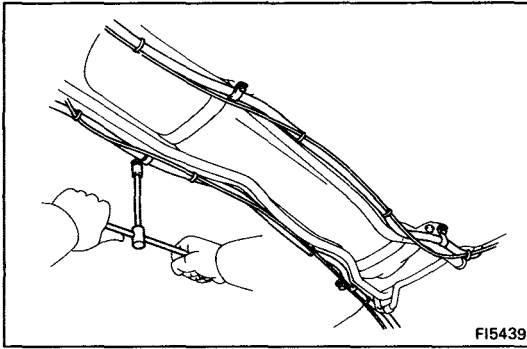

FI5439

**5. INSTALL A/C HOSES TO BODY**

Install the two A/C hoses with the four bolts.

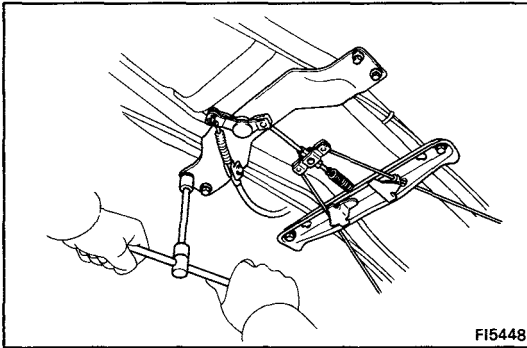

FI5448

**6. INSTALL PARKING BRAKE INTERMEDIATE LEVER AND NO.1 CENTER FLOOR CROSSMEMBER**

- (a) Connect the parking brake cable to the intermediate lever.
- (b) Install the intermediate lever with the four bolts.
- (c) Install the crossmember with the two bolts.

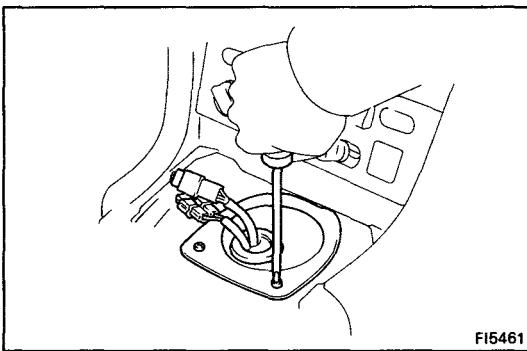

FI5461

**7. CONNECT FUEL PUMP CONNECTOR AND FUEL SENDER GAUGE CONNECTOR**

- (a) Install the floor service hole cover with the two screws.
- (b) Connect the fuel pump connector and fuel sender gauge connector.
- (c) Install the following parts:
  - Ash receptacle retainer
  - Ash receptacle box
  - Center instrument finish panel
  - LH rear lower instrument finish panel
  - Console boxes

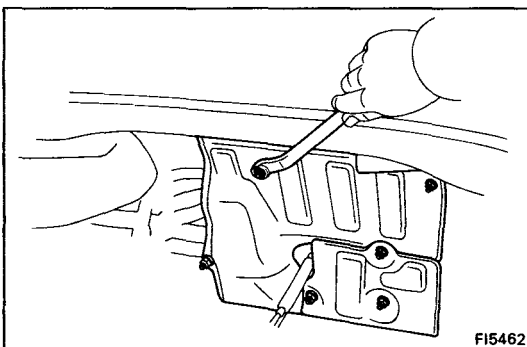
**8. FILL WITH FUEL****9. CHECK FOR FUEL LEAKAGE (See page FI-9)**

FI5462

**10. INSTALL FUEL TANK HEAT INSULATORS**

Remove the six nuts and two heat insulators.

**11. INSTALL ENGINE UNDER COVERS****12. INSTALL FUEL TANK PROTECTORS****13. INSTALL FRONT LUGGAGE UNDER COVER****14. CONNECT CABLE TO NEGATIVE TERMINAL OF BATTERY**



## Cold Start Injector (5S-FE)

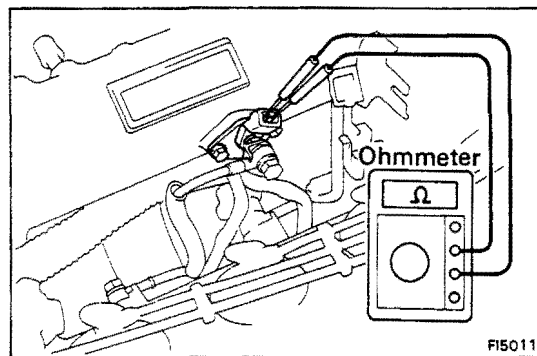
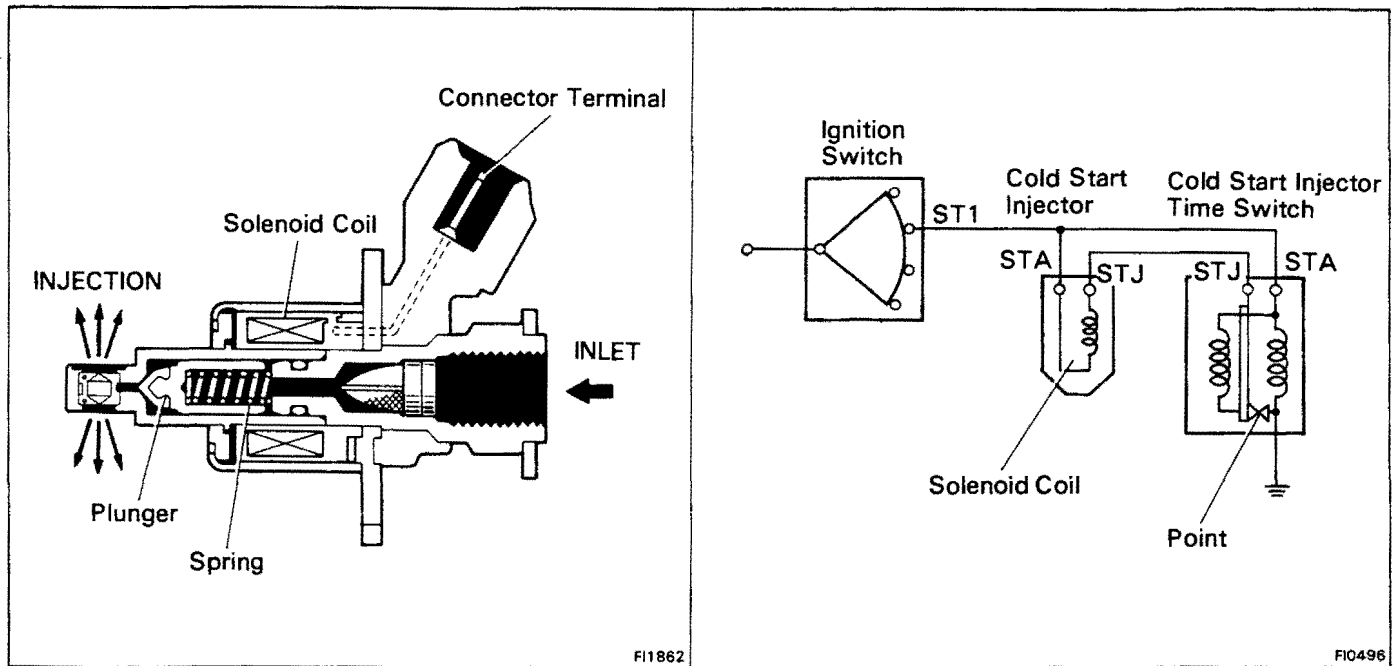

### ON-VEHICLE INSPECTION

#### INSPECT RESISTANCE OF COLD START INJECTOR

- (a) Disconnect the cold start injector connector.
- (b) Using an ohmmeter, measure the resistance between the terminals.

**Resistance: 2 – 4 Ω**

If the resistance is not as specified, replace the cold start injector.

- (c) Reconnect the cold start injector connector.

### REMOVAL OF COLD START INJECTOR

1. DISCONNECT CABLE FROM NEGATIVE TERMINAL OF BATTERY
2. DISCONNECT COLD START INJECTOR CONNECTOR

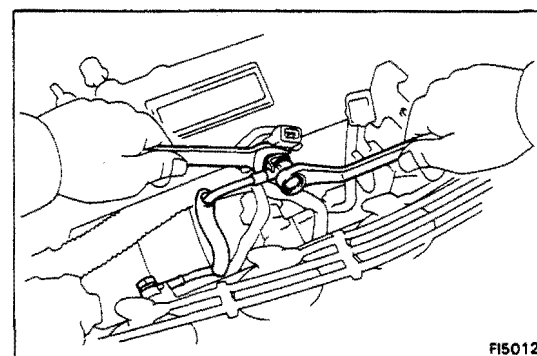

3. REMOVE COLD START INJECTOR PIPE

- (a) Put a suitable container or shop towel under the injector tube.
- (b) Remove the two union bolts and four gaskets and injector pipe.

**HINT:** Slowly loosen the union bolt.

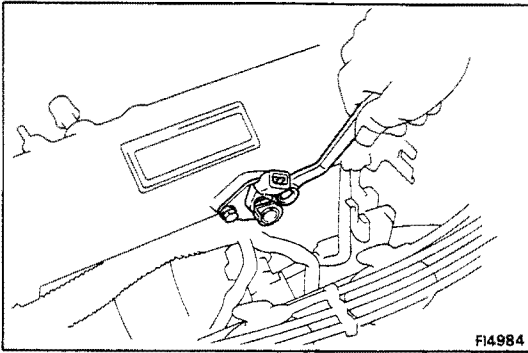

**4. REMOVE COLD START INJECTOR**

Remove the two bolts, cold start injector and gasket.

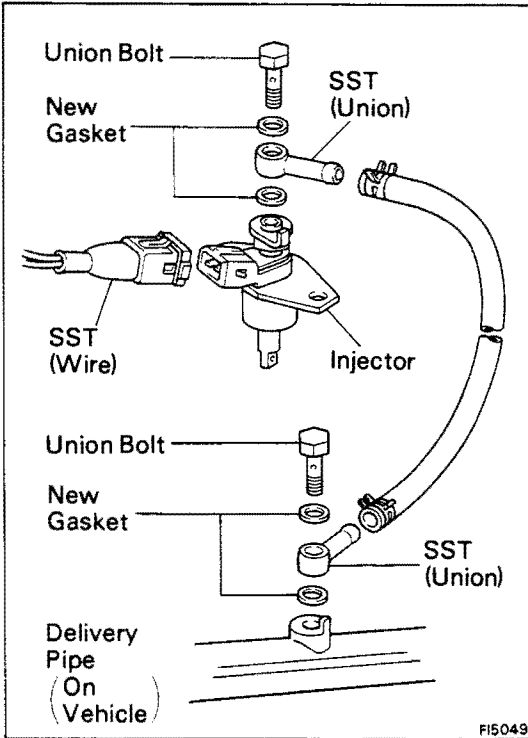

**INSPECTION OF COLD START INJECTOR**

**1. INSPECT INJECTION OF COLD START INJECTOR**

**CAUTION:** Keep injector clear of sparks during the test.

(a) Install SST (two unions) to the injector and delivery pipe with new gaskets and the union bolts.

SST 09268-41045 (09268-41080)

(b) Connect SST (hose) to the unions.

SST 09268-41045

(c) Connect SST (wire) to the injector.

SST 09842-30050

(d) Put a container under the injector.

(e) Reconnect the battery negative (-) cable.

(f) Turn the ignition switch ON.

**NOTICE:** Do not start the engine.

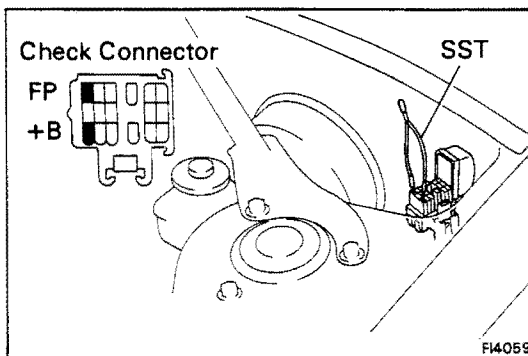

(g) Using SST, connect terminals +B and FP of the check connector.

SST 09843-18020

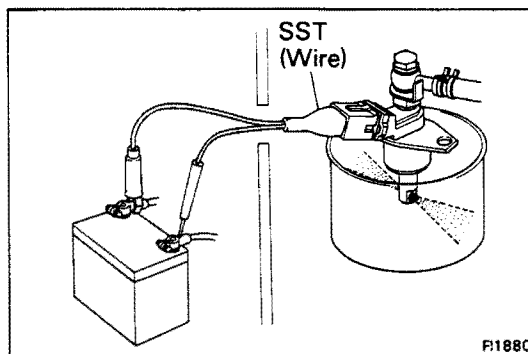

(h) Connect the test probes of the SST (wire) to the battery, and check that the fuel spray is as shown.

SST 09842-30050

**NOTICE:** Perform this check within the shortest possible time.

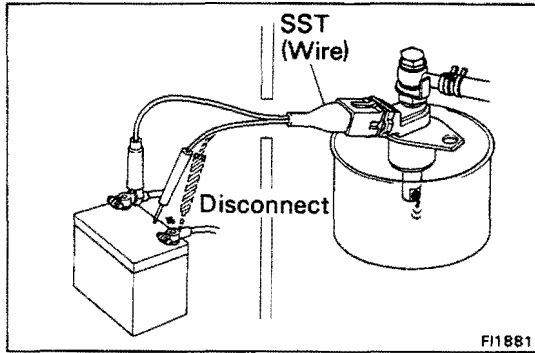

## 2. INSPECT LEAKAGE

- (a) In the condition above, disconnect the test probes of SST (wire) from the battery and check fuel leakage from the injector.

SST 09842-30050

**Fuel drop: One drop or less per minute**

- (b) Disconnect the battery negative (-) cable.  
 (c) Remove SST.

SST 09268-41045, 09842-30050 and 09843-18020

## INSTALLATION OF COLD START INJECTOR

### 1. INSTALL COLD START INJECTOR

Install a new gasket and the injector with the two bolts.

**Torque: 95 kg-cm (82 in.-lb, 9.3 N·m)**

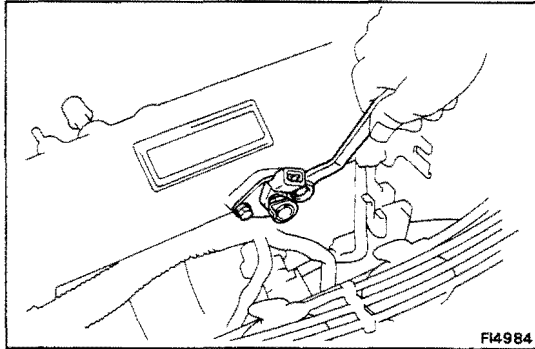

### 2. INSTALL COLD START INJECTOR PIPE

Install the injector pipe with four new gaskets and the two union bolts.

**Torque: 180 kg-cm (13 ft-lb, 18 N·m)**

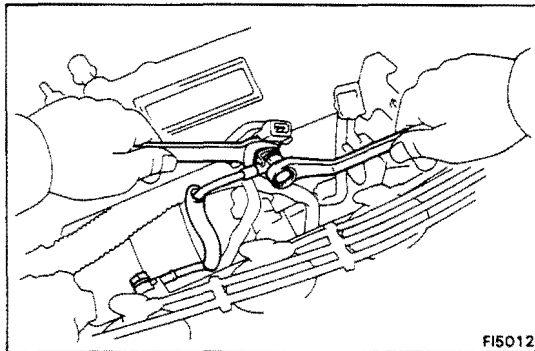

### 3. CONNECT COLD START INJECTOR CONNECTOR

### 4. CONNECT CABLE TO NEGATIVE TERMINAL OF BATTERY

### 5. CHECK FOR FUEL LEAKAGE (See page FI-11)

## Cold Start Injector (3S-GE)

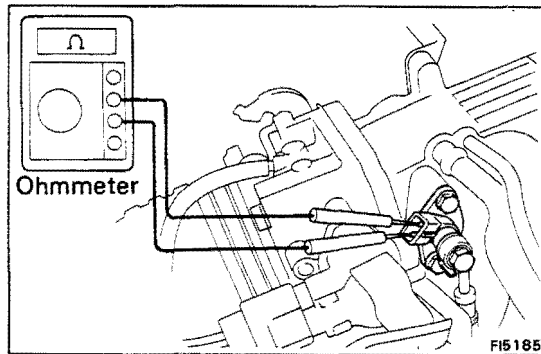
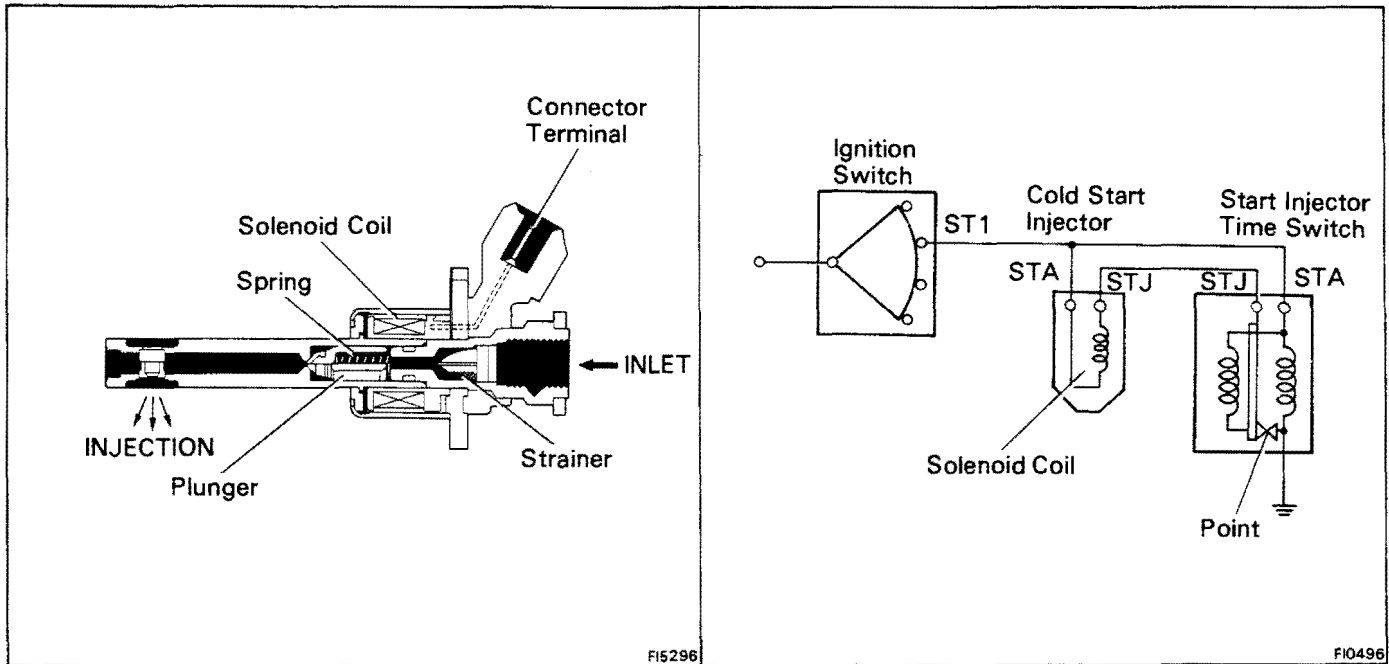

### ON-VEHICLE INSPECTION

#### INSPECT RESISTANCE OF COLD START INJECTOR

- (a) Disconnect the cold start injector connector.
- (b) Using an ohmmeter, measure the resistance between the terminals.

**Resistance: 2 – 4 Ω**

If the resistance is not as specified, replace the cold start injector.

- (c) Reconnect the cold start injector connector.

### REMOVAL OF COLD START INJECTOR

1. DISCONNECT CABLE FROM NEGATIVE TERMINAL OF BATTERY
2. DISCONNECT COLD START INJECTOR CONNECTOR

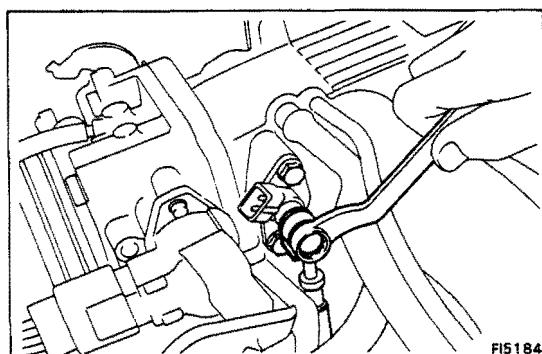

3. DISCONNECT COLD START INJECTOR PIPE

- (a) Put a suitable container or shop towel under the injector pipe.
- (b) Remove the union bolt and two gaskets, and disconnect the injector pipe.

**HINT:** Slowly loosen the union bolt.

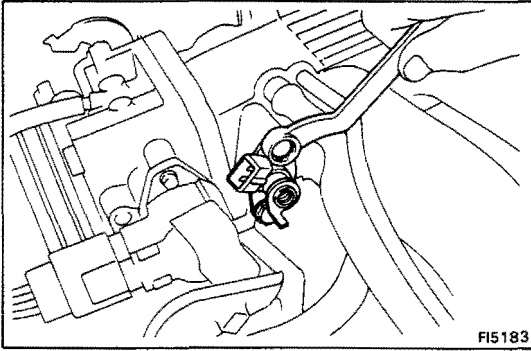

FI5183

**4. REMOVE COLD START INJECTOR**

Remove the two bolts, cold start injector and gasket.

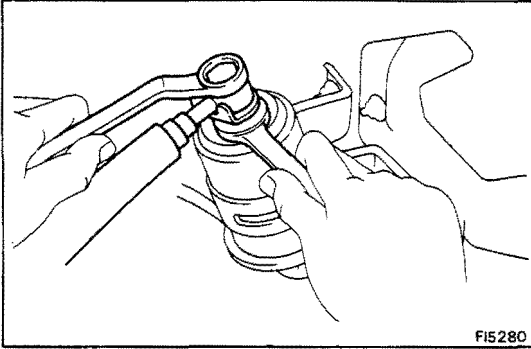

FI5280

**INSPECTION OF COLD START INJECTOR**

**1. INSPECT INJECTION OF COLD START INJECTOR**

**CAUTION:** Keep injector clear of sparks during the test.

- (a) Put a suitable container or shop towel under the fuel filter.
- (b) Remove the union bolt and two gaskets, and disconnect the fuel inlet hose from the fuel filter outlet.

**HINT:** Slowly loosen the union bolt.

- (c) Install SST (two unions) to the injector and fuel filter outlet with new gaskets and the union bolts.

SST 09268-41045 (09268-41080, 09405-09015)

- (d) Connect SST (hose) to the unions.

SST 09268-41045

- (e) Connect SST (wire) to the injector.

SST 09842-30050

- (f) Put a container under the injector.

- (g) Reconnect the battery negative (-) cable.

- (h) Turn the ignition switch ON.

**NOTICE:** Do not start the engine.

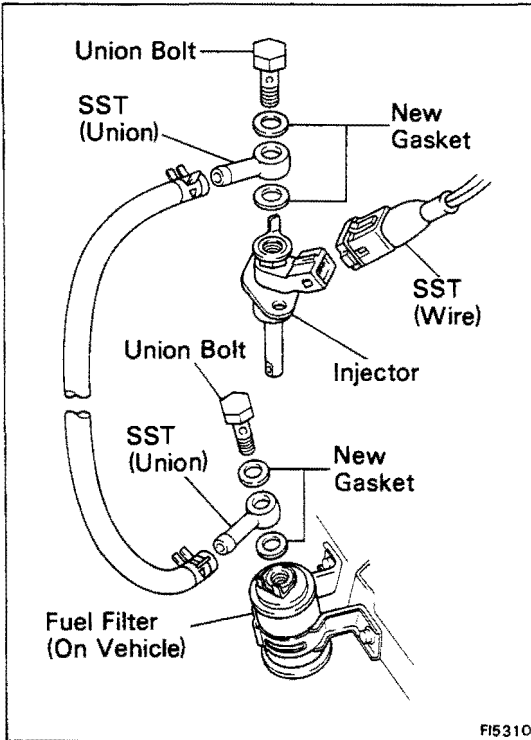

FI5310

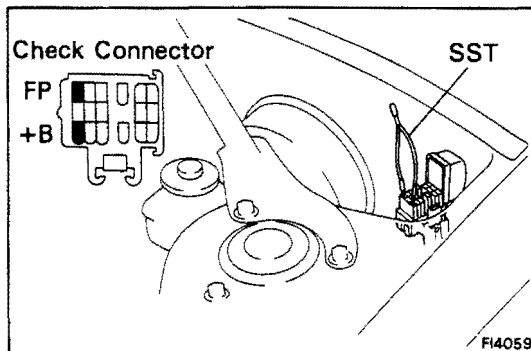

FI4059

- (i) Using SST, connect terminals +B and FP of the check connector.

SST 09843-18020

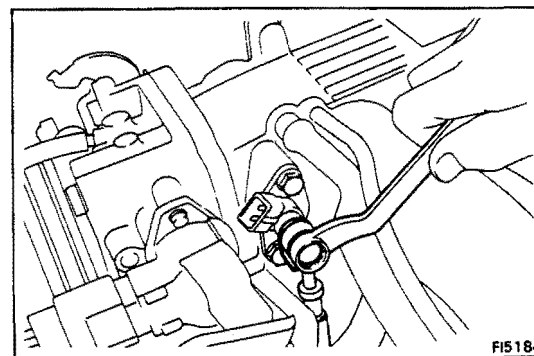
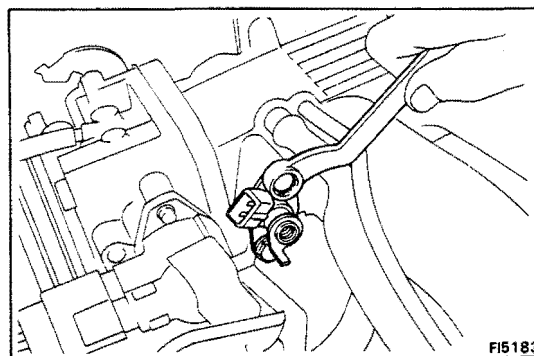
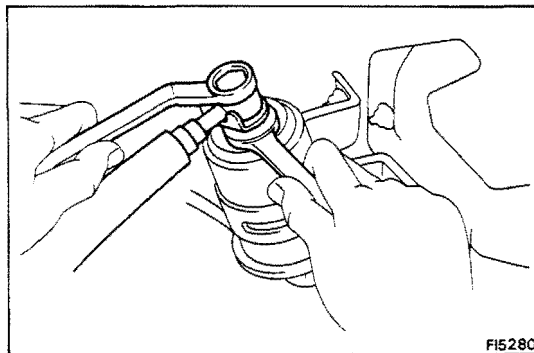
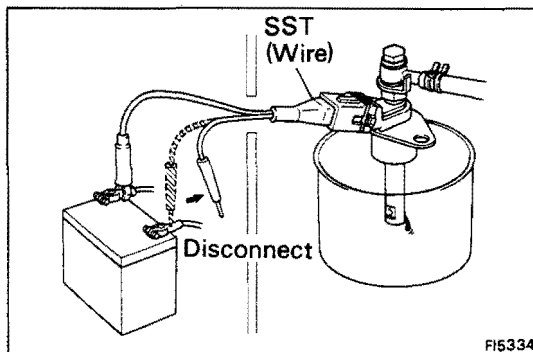
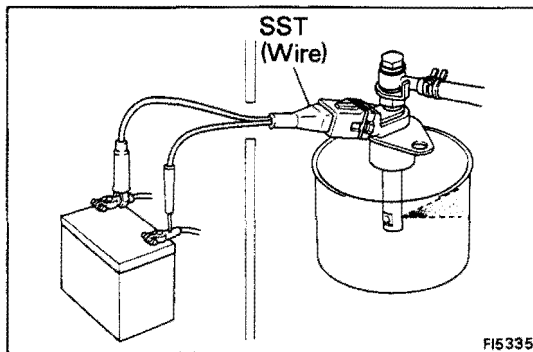

- (j) Connect the test probes of the SST (wire) to the battery, and check that the fuel spray is as shown.

SST 09842-30050

**NOTICE:** Perform this check within the shortest possible time.

## 2. INSPECT LEAKAGE

- (a) In the condition above, disconnect the test probes of SST (wire) from the battery and check fuel leakage from the injector.

SST 09842-30050

**Fuel drop: One drop or less per minute**

- (b) Disconnect the battery negative (-) cable.

- (c) Remove SST.

SST 09268-41045, 09842-30050 and 09843-18020

- (d) Connect the fuel inlet hose with two new gaskets and the union bolt.

**Torque: 300 kg-cm (22 ft-lb, 29 N·m)**

## INSTALLATION OF COLD START INJECTOR

### 1. INSTALL COLD START INJECTOR

Install a new gasket and the injector with the two bolts.

**Torque: 60 kg-cm (52 in.-lb, 5.9 N·m)**

### 2. CONNECT COLD START INJECTOR PIPE

Install the injector pipe with two new gaskets and the union bolt.

**Torque: 180 kg-cm (13 ft-lb, 18 N·m)**

### 3. CONNECT COLD START INJECTOR CONNECTOR

### 4. CONNECT CABLE TO NEGATIVE TERMINAL OF BATTERY

### 5. CHECK FOR FUEL LEAKAGE (See page FI-11)

## Cold Start Injector (3S-GTE)

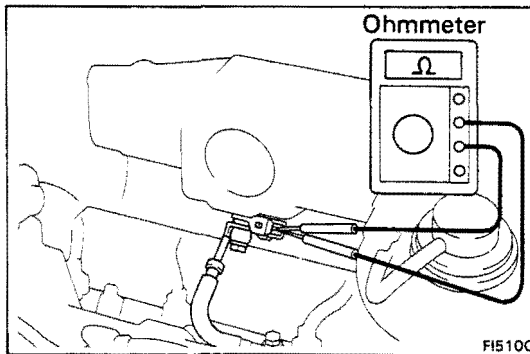
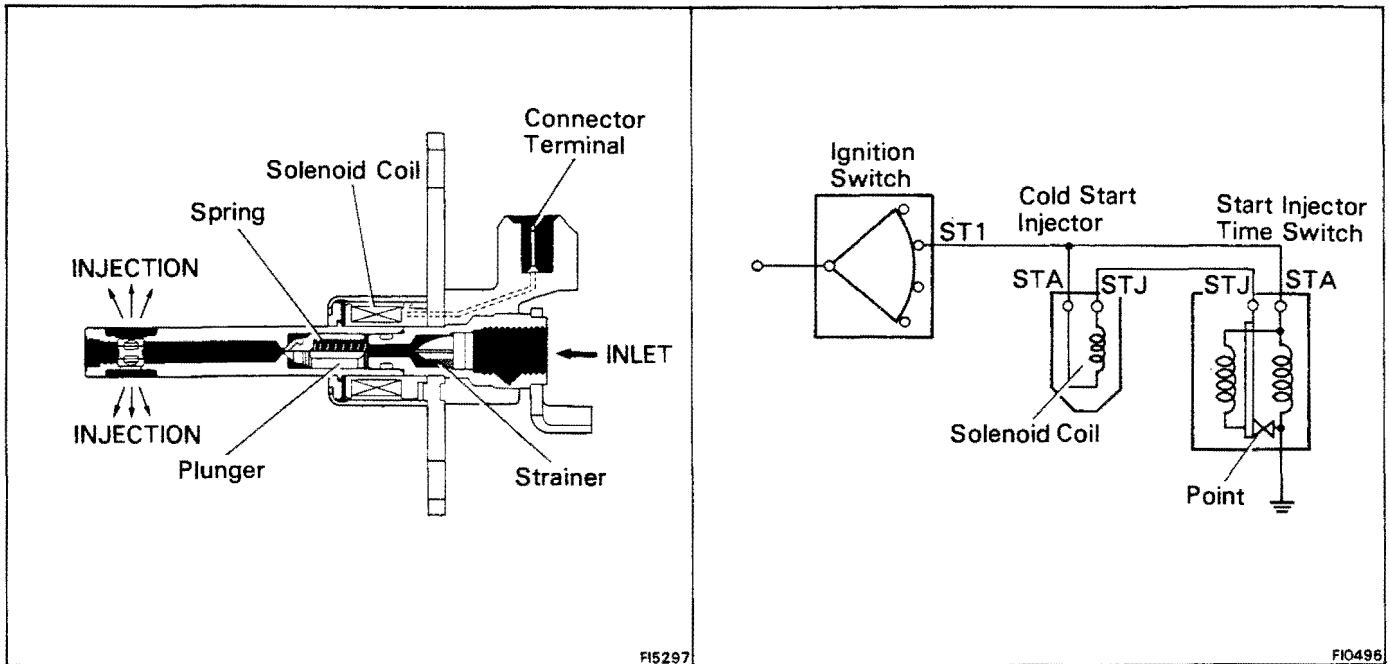

### ON-VEHICLE INSPECTION

#### INSPECT RESISTANCE OF COLD START INJECTOR

- Remove the throttle body.  
(See steps 1 to 10 on pages FI-170, 171)
- Disconnect the cold start injector connector.
- Using an ohmmeter, measure the resistance between the terminals.

**Resistance: 2 – 4  $\Omega$**

If the resistance is not as specified, replace the cold start injector.

- Reconnect the cold start injector connector.
- Reinstall the throttle body.  
(See steps 2 to 12 on pages FI-172, 173)

### REMOVAL OF COLD START INJECTOR

- REMOVE THROTTLE BODY**  
(See steps 1 to 10 on pages FI-170, 171)
- DISCONNECT COLD START INJECTOR CONNECTOR**
- REMOVE COLD START INJECTOR PIPE**
  - Put a suitable container or shop towel under the injector pipe.
  - Remove the two union bolts and four gaskets and injector pipe.

**HINT:** Slowly loosen the union bolts.

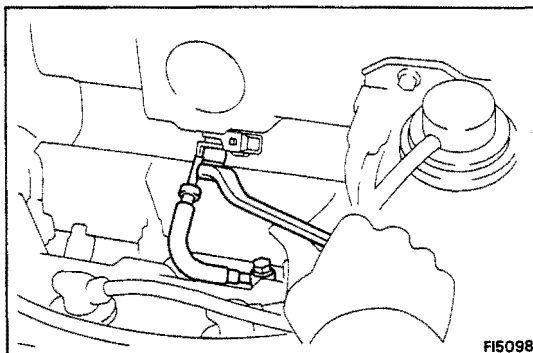

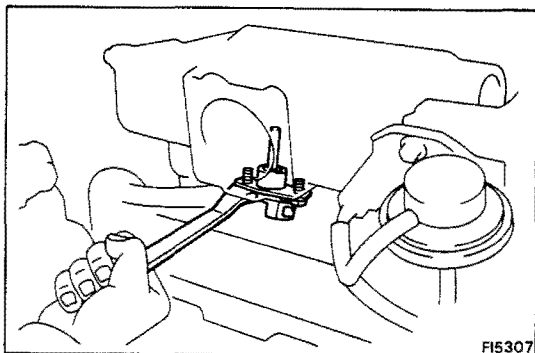

#### 4. REMOVE COLD START INJECTOR

Remove the two bolts, cold start injector and gasket.

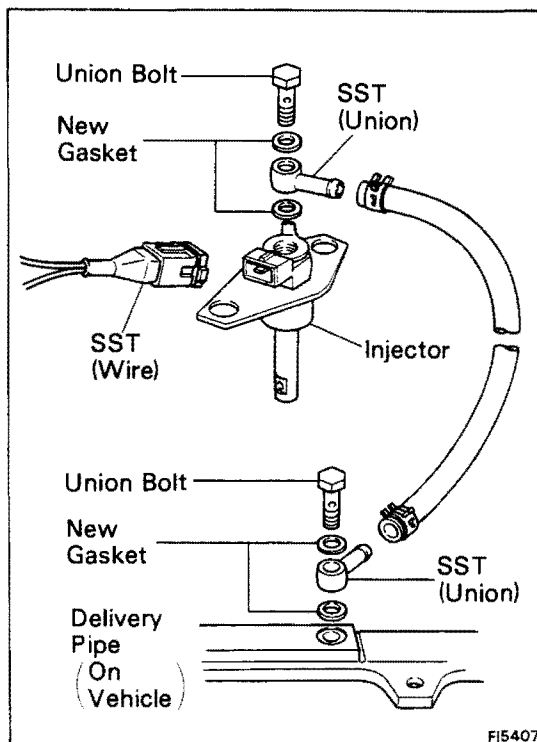

### INSPECTION OF COLD START INJECTOR

#### 1. INSPECT INJECTION OF COLD START INJECTOR

**CAUTION:** Keep injector clear of sparks during the test.

(a) Install SST (two unions) to the injector and delivery pipe with new gaskets and the union bolts.

SST 09268-41045 (09268-41080)

(b) Connect SST (hose) to the unions.

SST 09268-41045

(c) Connect SST (wire) to the injector.

SST 09842-30050

(d) Put a container under the injector.

(e) Reconnect the battery negative (–) cable.

(f) Turn the ignition switch ON.

**NOTICE:** Do not start the engine.

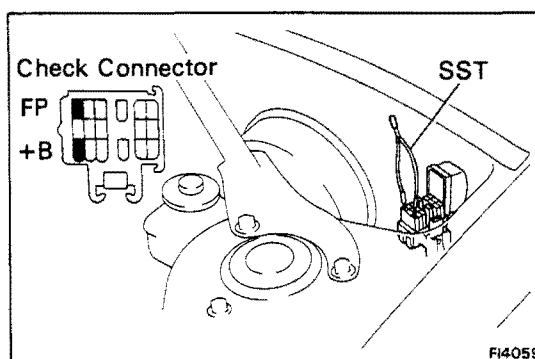

(g) Using SST, connect terminals +B and FP of the check connector.

SST 09843-18020

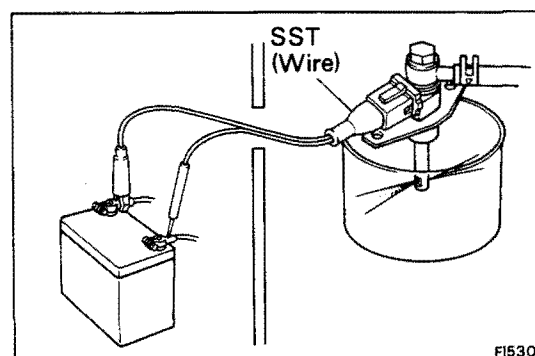

(h) Connect the test probes of the SST (wire) to the battery, and check that the fuel spray is as shown.

SST 09842-30050

**NOTICE:** Perform this check within the shortest possible time.



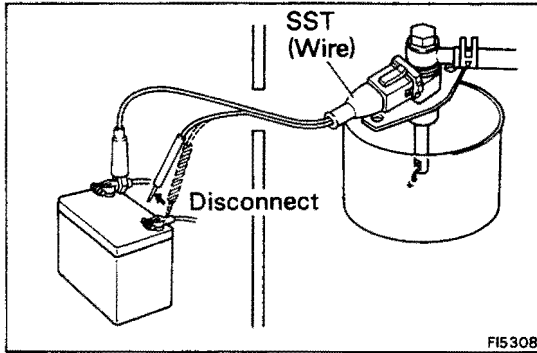

## 2. INSPECT LEAKAGE

- (a) In the condition above, disconnect the test probes of SST (wire) from the battery and check fuel leakage from the injector.

SST 09842-30050

**Fuel drop: One drop or less per minute**

- (b) Disconnect the battery negative (-) cable.  
 (c) Remove SST.

SST 09268-41045, 09842-30050 and 09843-18020

## INSTALLATION OF COLD START INJECTOR

### 1. INSTALL COLD START INJECTOR

Install a new gasket and the injector with the two bolts.

**Torque: 60 kg-cm (52 in.-lb, 5.9 N·m)**

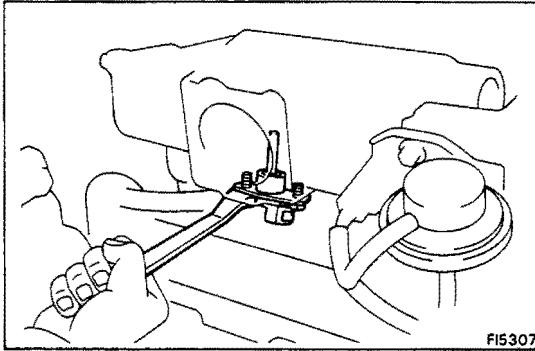

### 2. INSTALL COLD START INJECTOR PIPE

Install the injector pipe with four new gaskets and the two union bolts.

**Torque: 180 kg-cm (13 ft-lb, 18 N·m)**

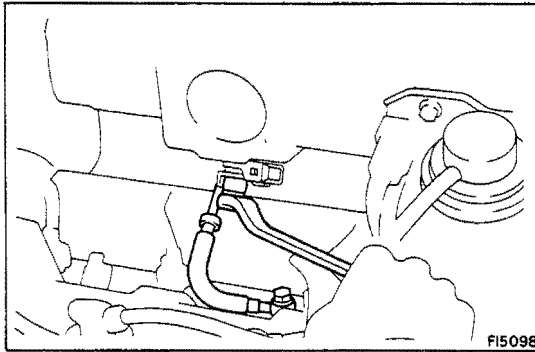

### 3. CONNECT COLD START INJECTOR CONNECTOR

### 4. INSTALL THROTTLE BODY

(See steps 2 to 12 on pages FI-172, 173)

## Fuel Pressure Regulator (5S-FE)

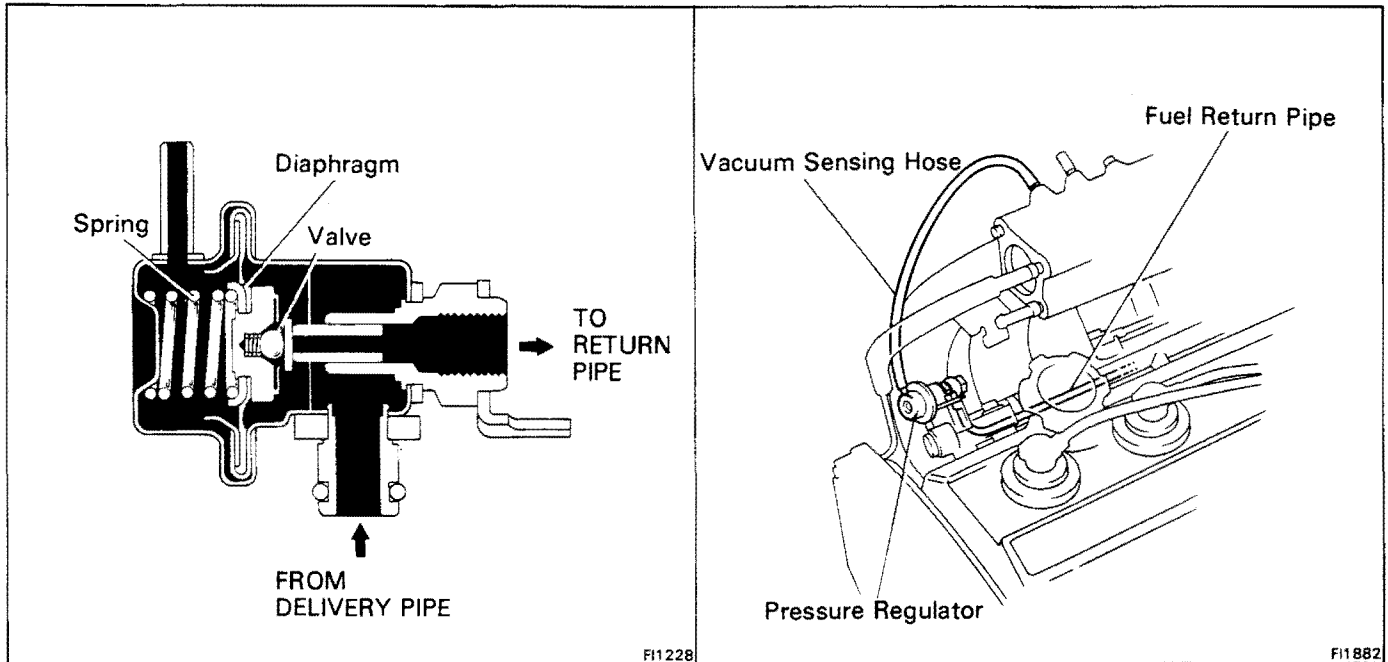

### ON-VEHICLE INSPECTION

INSPECT FUEL PRESSURE (See page FI-105)

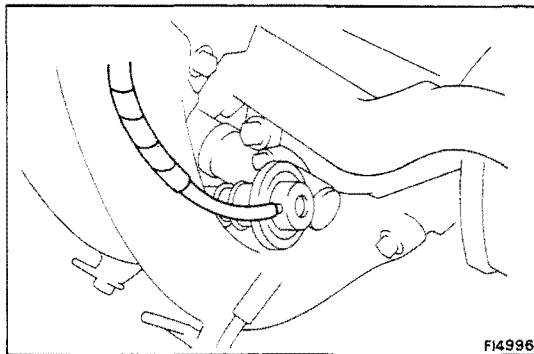

### REMOVAL OF FUEL PRESSURE REGULATOR

1. DISCONNECT VACUUM SENSING HOSE FROM FUEL PRESSURE REGULATOR

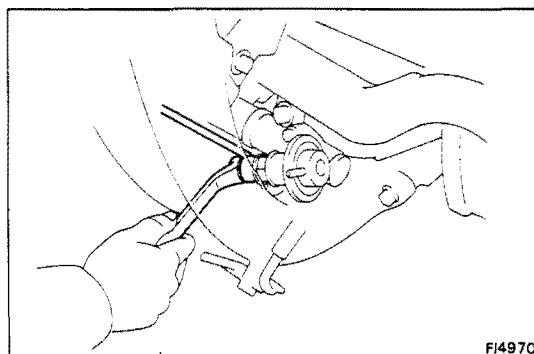

2. DISCONNECT FUEL RETURN PIPE FROM FUEL PRESSURE REGULATOR
  - (a) Put a suitable container or shop towel under the pressure regulator.
  - (b) Remove the union bolt and two gaskets, and disconnect the return pipe from the pressure regulator.

HINT: Slowly loosen the union bolt.

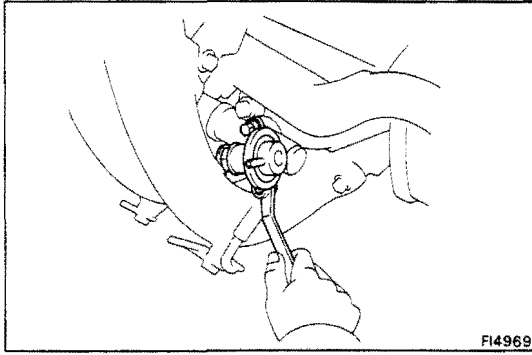

FI4969

### 3. REMOVE FUEL PRESSURE REGULATOR

- (a) Remove the two bolts, and pull out the pressure regulator.
- (b) Remove the O-ring from the pressure regulator.

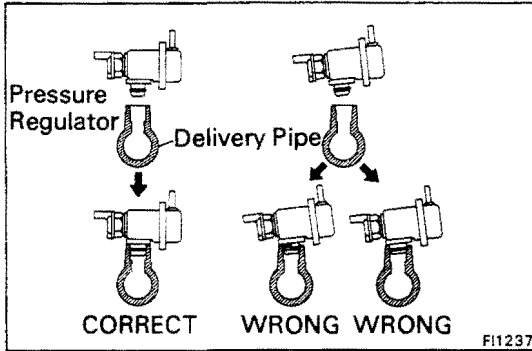

FI1237

## INSTALLATION OF FUEL PRESSURE REGULATOR

### 1. INSTALL FUEL PRESSURE REGULATOR

- (a) Apply a light coat of gasoline to a new O-ring, and install it to the pressure regulator.

- (b) Install the pressure regulator with the two bolts.

**Torque: 55 kg-cm (48 in.-lb, 5.4 N·m)**

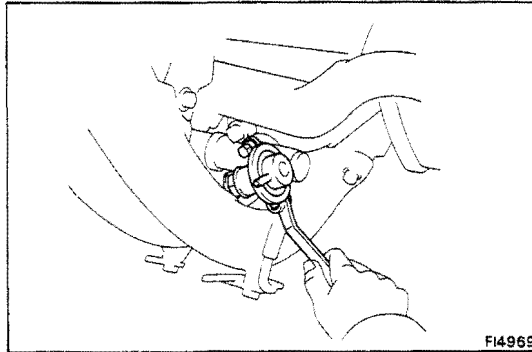

FI4969

### 2. CONNECT FUEL RETURN PIPE TO FUEL PRESSURE REGULATOR

Connect the return pipe with two new gaskets and the union bolt.

**Torque: 180 kg-cm (13 ft-lb, 18 N·m)**

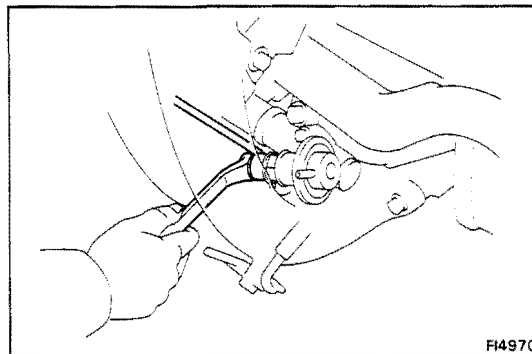

FI4970

### 3. CONNECT VACUUM SENSING HOSE TO FUEL PRESSURE REGULATOR

### 4. CHECK FOR FUEL LEAKAGE (See page FI-11)

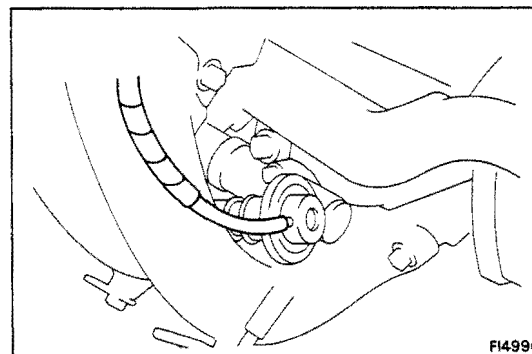

FI4996

## Fuel Pressure Regulator (3S-GE)

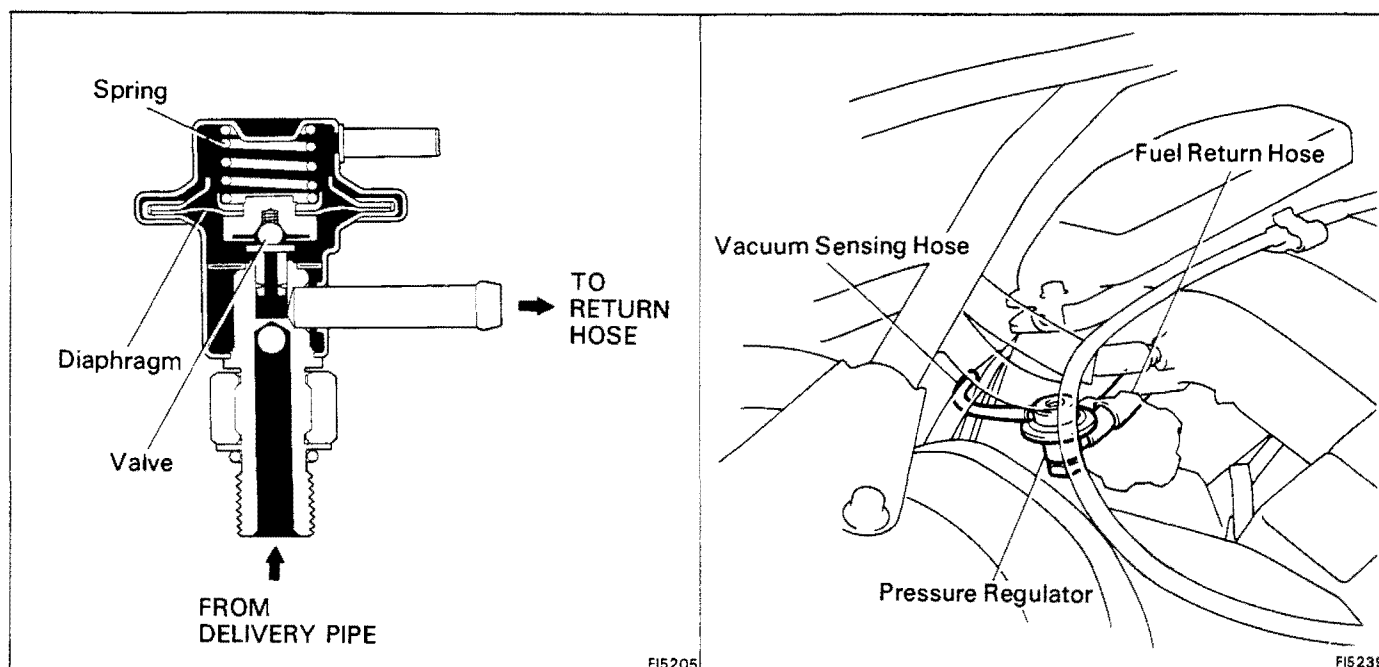

### ON-VEHICLE INSPECTION

INSPECT FUEL PRESSURE (See page FI-108)

### REMOVAL OF FUEL PRESSURE REGULATOR

1. REMOVE INTAKE MANIFOLD  
(See steps 1 to 13 on pages FI-141 to 143)
2. DISCONNECT FUEL RETURN HOSE AND PIPE FROM FUEL PRESSURE REGULATOR
3. REMOVE NO.2 ENGINE HANGER

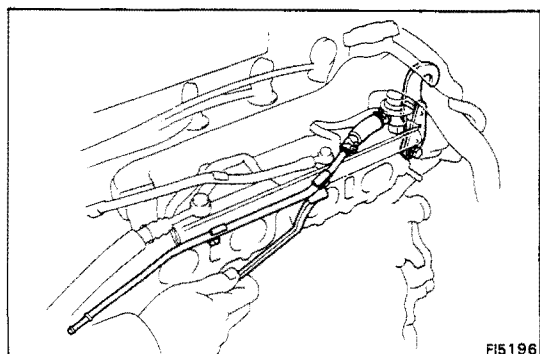

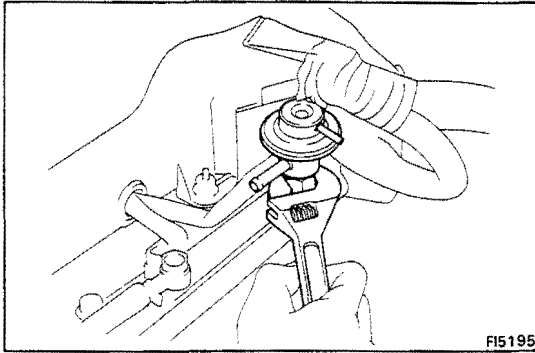

#### 4. REMOVE FUEL PRESSURE REGULATOR

- (a) Loosen the lock nut, and remove the pressure regulator.
- (b) Remove the O-ring from the pressure regulator.

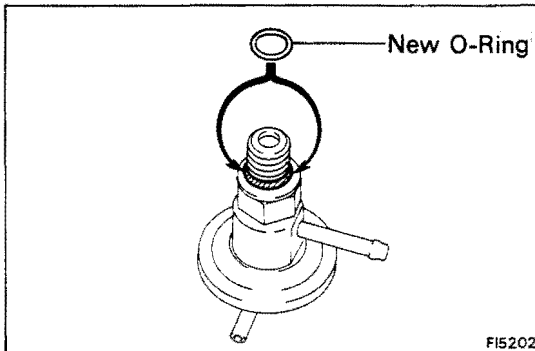

### INSTALLATION OF FUEL PRESSURE REGULATOR

#### 1. INSTALL FUEL PRESSURE REGULATOR

- (a) Fully loosen the lock nut of the pressure regulator.
- (b) Apply a light coat of gasoline to a new O-ring, and install it to the pressure regulator.
- (c) Thrust the pressure regulator completely into the delivery pipe by hand.
- (d) Turn the pressure regulator counterclockwise until the vacuum pipe faces in the direction indicated in the illustration.

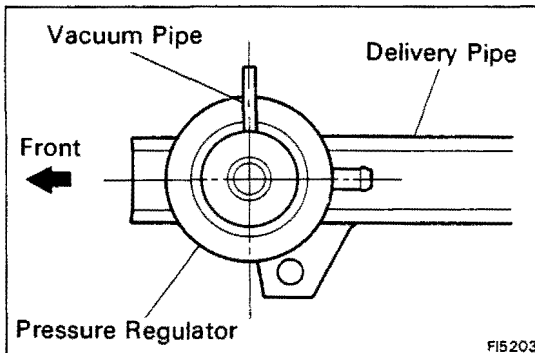

- (e) Tighten the lock nut.

**Torque: 300 kg-cm (22 ft-lb, 29 N·m)**

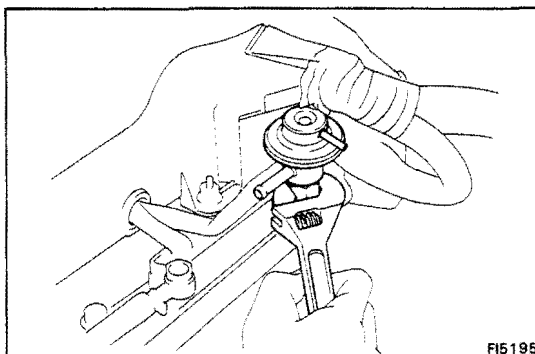

#### 2. INSTALL NO.2 ENGINE HANGER

#### 3. CONNECT FUEL RETURN PIPE AND HOSE TO FUEL PRESSURE REGULATOR

#### 4. INSTALL INTAKE MANIFOLD

(See steps 6 to 19 on pages FI-147 to 149)

#### 5. CHECK FOR FUEL LEAKAGE (See page FI-11)

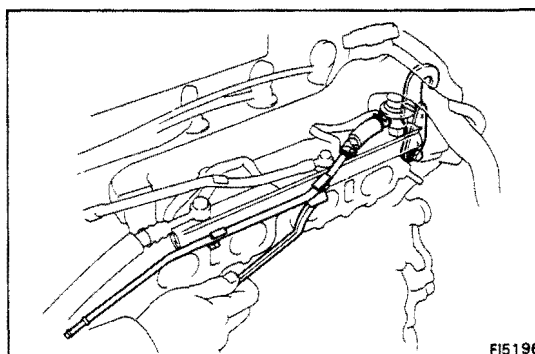

## Fuel Pressure Regulator (3S-GTE)

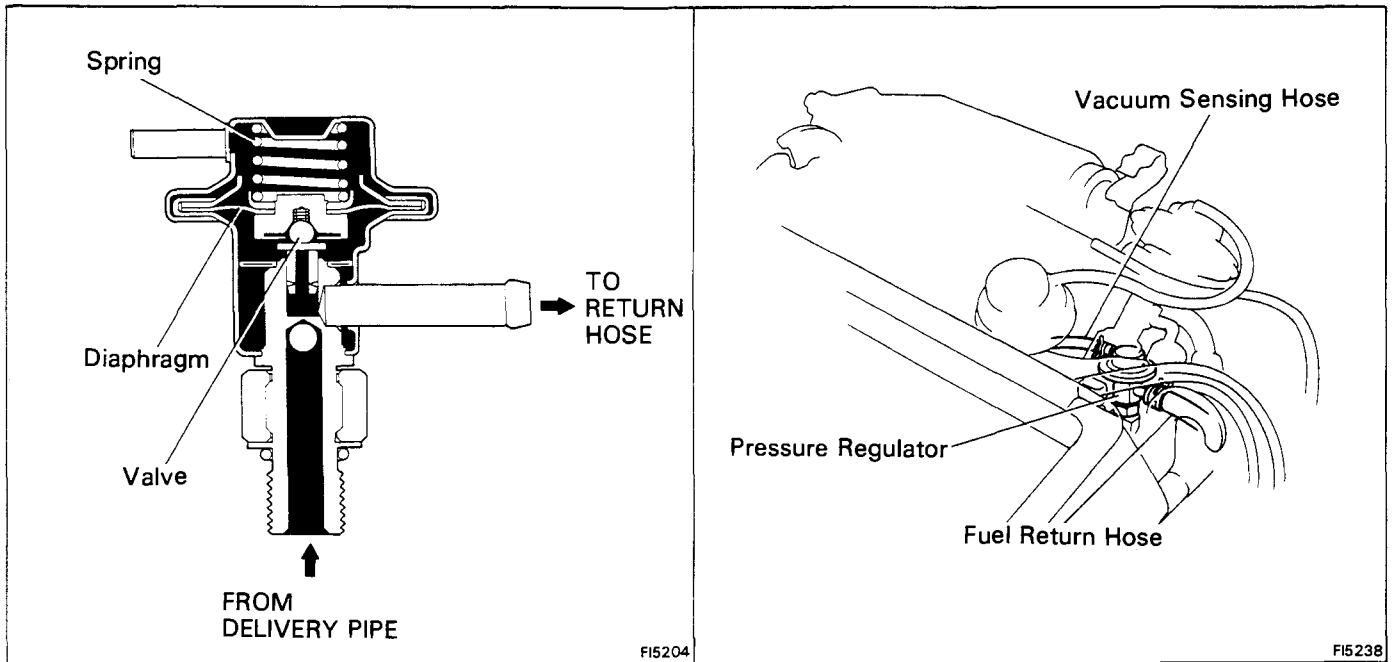

### ON-VEHICLE INSPECTION

INSPECT FUEL PRESSURE (See page FI-108)

### REMOVAL OF FUEL PRESSURE REGULATOR

1. REMOVE THROTTLE BODY  
(See steps 1 to 10 on pages FI-170, 171)
2. REMOVE COLD START INJECTOR PIPE  
(See step 3 on page FI-124)
3. REMOVE INTAKE MANIFOLD AND T-VIS VALVE  
(See steps 20 to 23 on pages EM-112, 113)
4. DISCONNECT FUEL INLET HOSE FROM DELIVERY PIPE
  - (a) Remove the union bolt and two gaskets.
  - (b) Remove the bolt and disconnect the fuel inlet hose.
5. DISCONNECT FUEL RETURN HOSE FROM FUEL PRESSURE REGULATOR

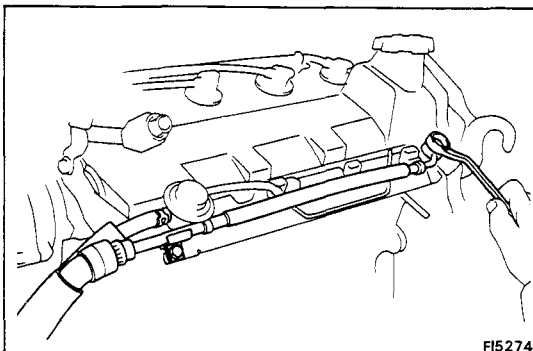

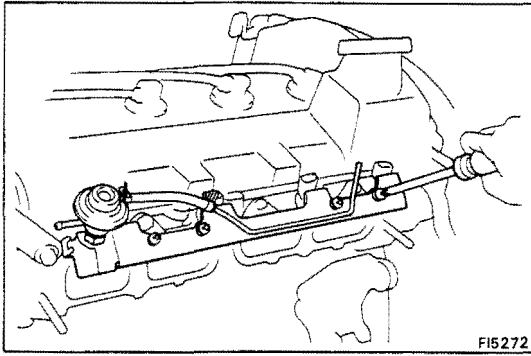

FI5272

**6. REMOVE INJECTOR COVER**

Remove the four screws, injector cover and four insulators.

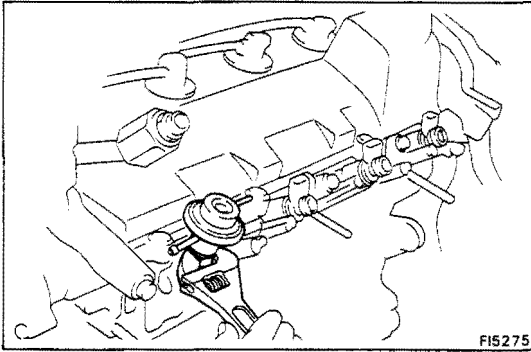

FI5275

**7. REMOVE FUEL PRESSURE REGULATOR**

- (a) Loosen the lock nut, and remove the pressure regulator.
- (b) Remove the O-ring from the pressure regulator.

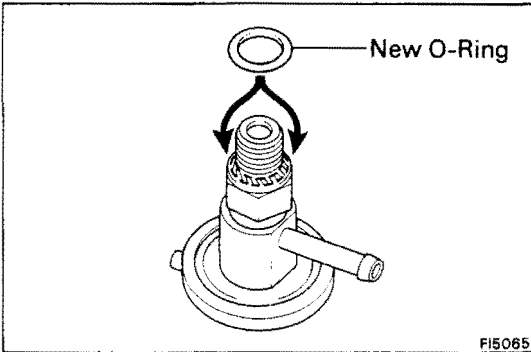

FI5065

**INSTALLATION OF FUEL PRESSURE REGULATOR**

**1. INSTALL FUEL PRESSURE REGULATOR**

- (a) Fully loosen the lock nut of the pressure regulator.
- (b) Apply a light coat of gasoline to a new O-ring, and install it to the pressure regulator.
- (c) Thrust the pressure regulator completely into the delivery pipe by hand.
- (d) Turn the pressure regulator counterclockwise until the vacuum pipe faces in the direction indicated in the illustration.

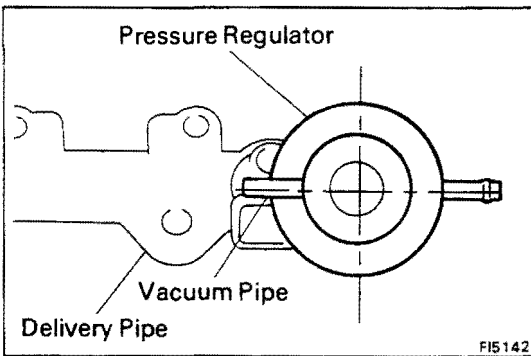

FI5142

- (e) Tighten the lock nut.

**Torque: 300 kg-cm (22 ft-lb, 29 N·m)**

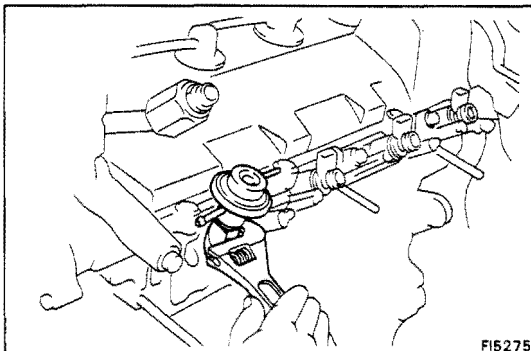

FI5275

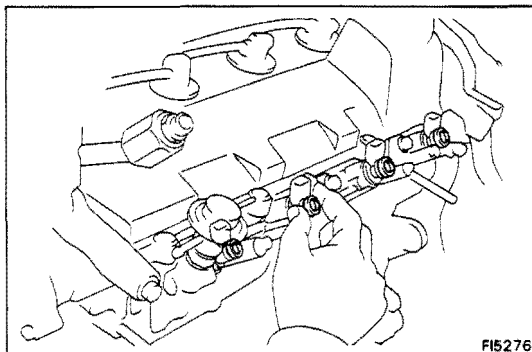
**2. INSTALL INJECTOR COVER**

- (a) Install four new insulators to the injectors.

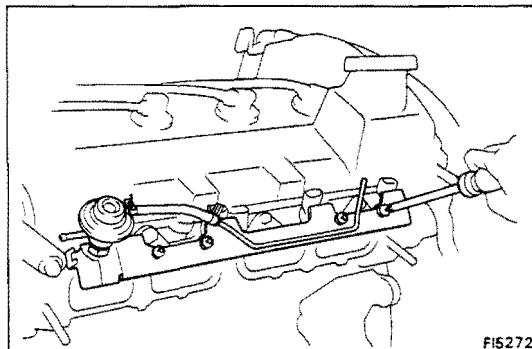

- (b) Install the injector cover with the four screws.

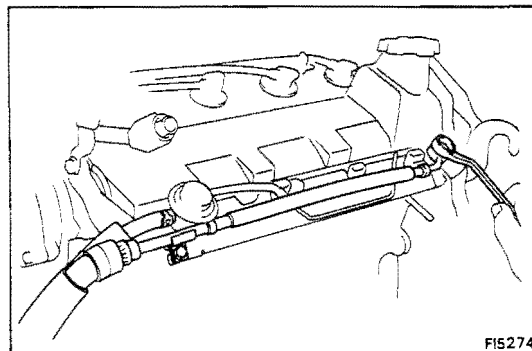
**3. CONNECT FUEL RETURN HOSE TO FUEL PRESSURE REGULATOR****4. CONNECT FUEL INLET HOSE TO DELIVERY PIPE**

- (a) Connect the fuel inlet hose to the delivery pipe with the union bolt.

**Torque: 300 kg-cm (22 ft-lb, 29 N·m)**

- (b) Install the fuel inlet hose clamp bolt.

**5. INSTALL T-VIS VALVE AND INTAKE MANIFOLD  
(See steps 10 to 13 on pages EM-141, 142)****6. INSTALL COLD START INJECTOR PIPE  
(See step 2 on page FI-126)****7. INSTALL THROTTLE BODY  
(See steps 2 to 12 on pages FI-172, 173)**



## Injectors (5S-FE)

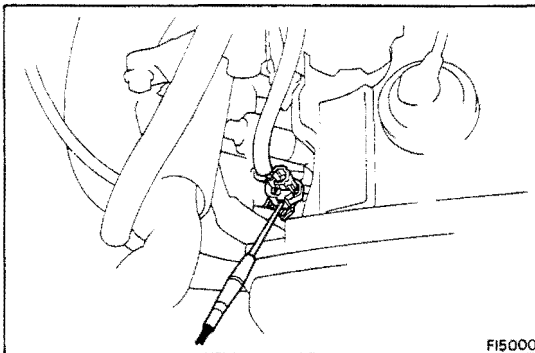
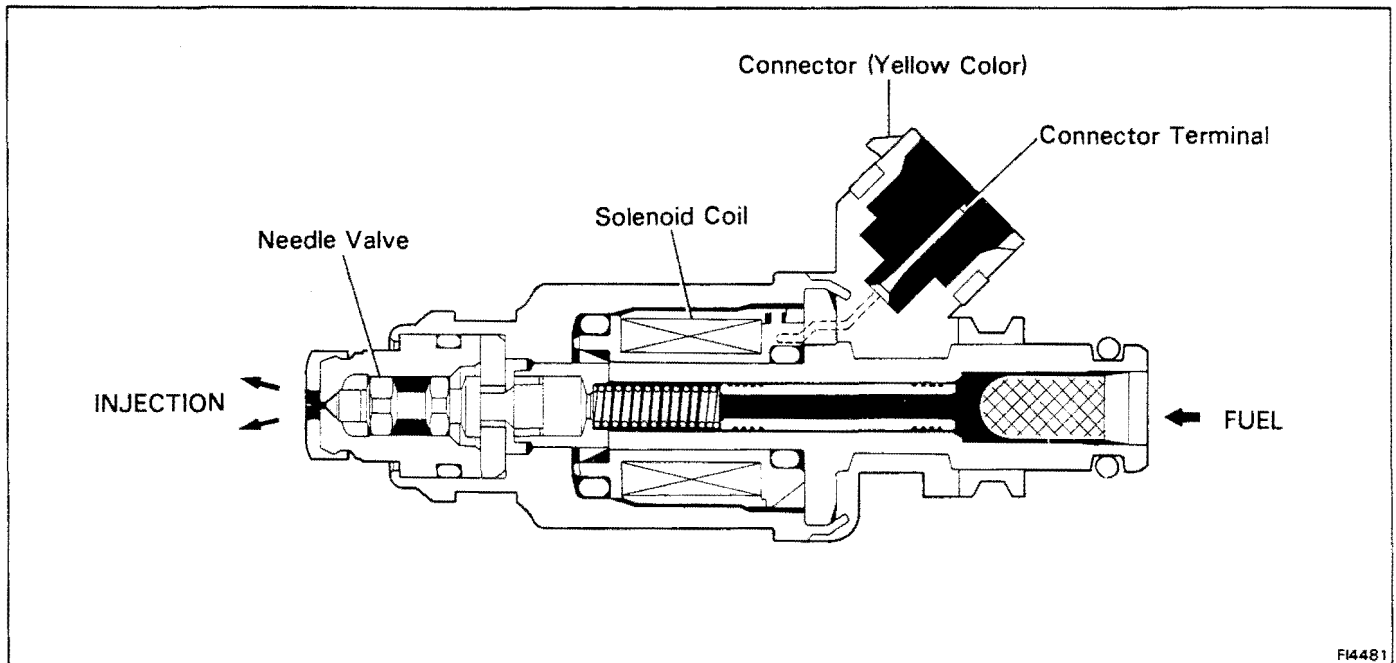

### ON-VEHICLE INSPECTION

#### 1. INSPECT INJECTOR OPERATION

Check operation sound from each injector.

- (a) With the engine running or cranking, use a sound scope to check that there is normal operating noise in proportion to engine rpm.

- (b) If you have no sound scope, you can check the injector transmission operation with your finger.

If no sound or an unusual sound is heard, check the wiring connector, injector or injection signal from the engine (and ECT) ECU.



#### 2. INSPECT INJECTOR RESISTANCE

- (a) Disconnect the injector connector.
- (b) Using an ohmmeter, measure the resistance between the terminals.

**Resistance: Approx. 13.8  $\Omega$**

If the resistance is not as specified, replace the injector.

- (c) Reconnect the injector connector.

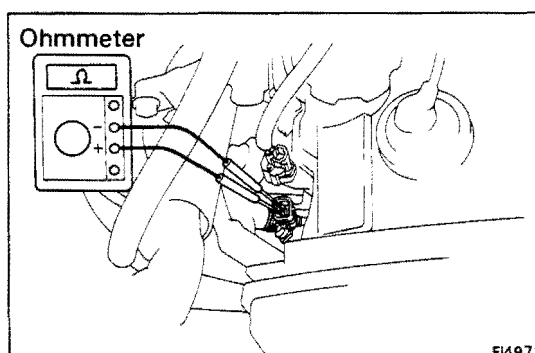

**REMOVAL OF INJECTORS**

1. **DISCONNECT CABLE FROM NEGATIVE TERMINAL OF BATTERY**

2. **REMOVE THROTTLE BODY**  
(See steps 2 to 9 on pages FI-159, 160)

3. **REMOVE COLD START INJECTOR PIPE**  
(See step 3 on page FI-118)

4. **REMOVE FUEL PRESSURE REGULATOR**  
(See steps 1 to 3 on pages FI-127, 128)

5. **REMOVE ACCELERATOR BRACKETS**

- (a) Remove the bolt and RH accelerator bracket.
- (b) Disconnect the clip of the engine wire from the LH accelerator bracket. Remove the two bolts and LH accelerator bracket.

6. **DISCONNECT INJECTOR CONNECTORS**

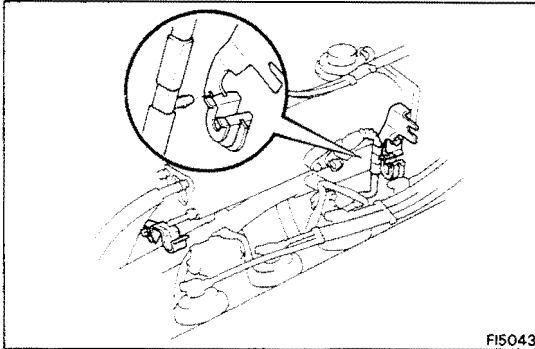

F15043

7. **DISCONNECT ENGINE WIRE**

- (a) Disconnect the two wire clamps from the mount bolts of the No.2 timing belt cover.

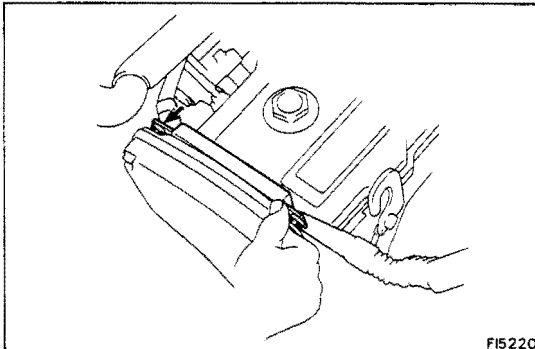

F15220

- (b) Disconnect the two wire clamps from the wire brackets on the intake manifold.

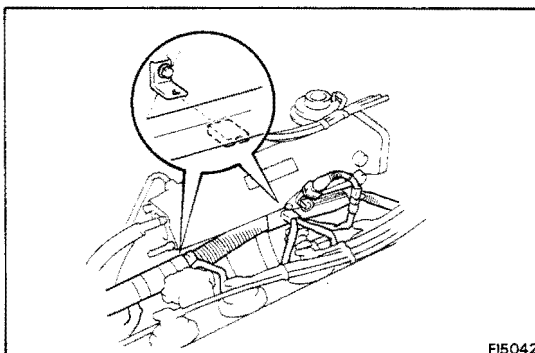

F15042

8. **DISCONNECT FUEL RETURN HOSE FROM RETURN PIPE**

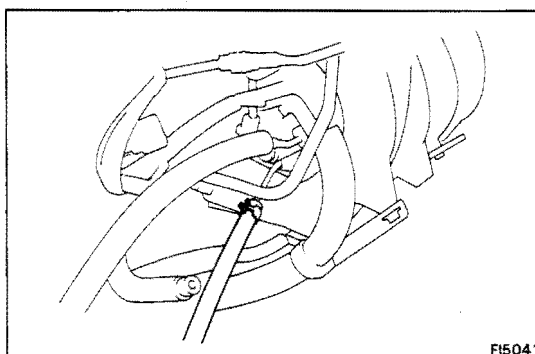

F15041

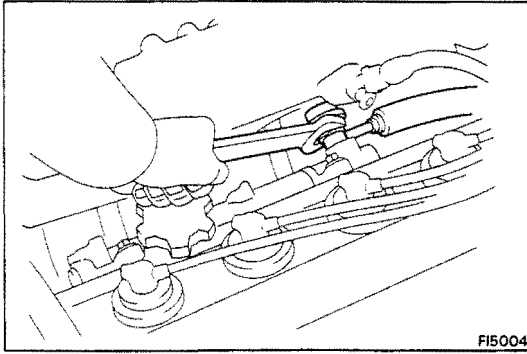

## 9. REMOVE DELIVERY PIPE AND INJECTORS

- (a) Loosen the pulsation damper.

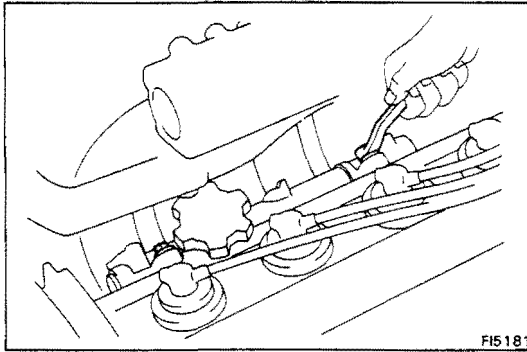

- (b) Loosen the two bolts holding the delivery pipe to the cylinder head.

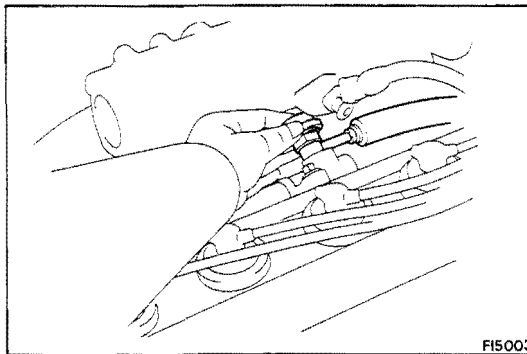

- (c) Remove the pulsation damper, and disconnect the fuel inlet hose from the delivery pipe.

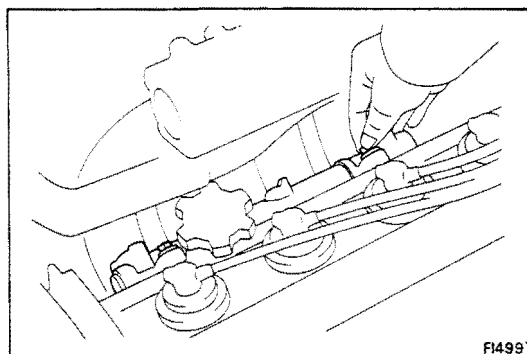

- (d) Remove the two bolts and delivery pipe together with four injectors.

**NOTICE:** Be careful not to drop the injectors, when removing the delivery pipe.

- (e) Remove the four insulators and two spacers from the cylinder head.
- (f) Pull out the four injectors from the delivery pipe.
- (g) Remove the O-ring and grommet from each injector.

## INSPECTION OF INJECTORS

### 1. INSPECT INJECTOR INJECTION

**CAUTION:** Keep injector clear of sparks during the test.

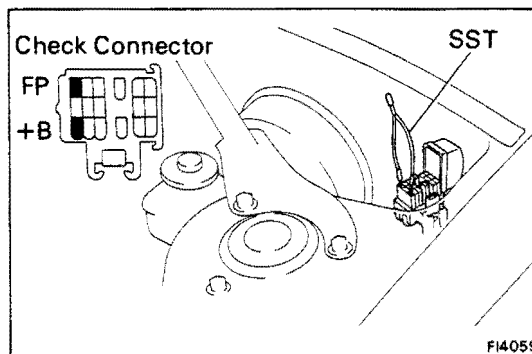
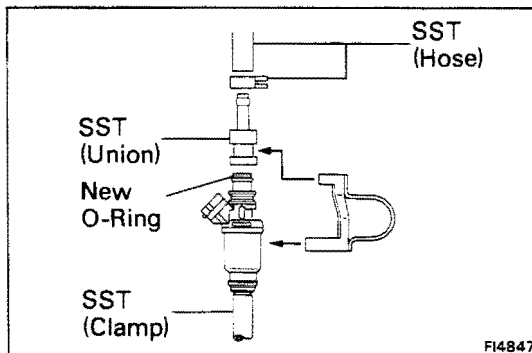
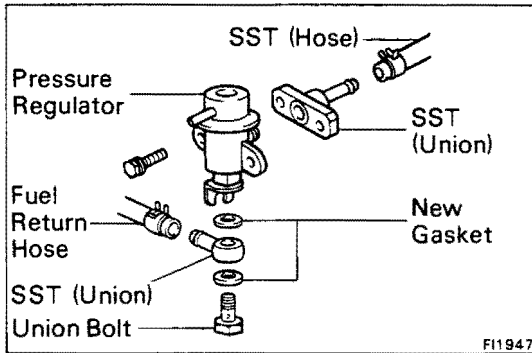
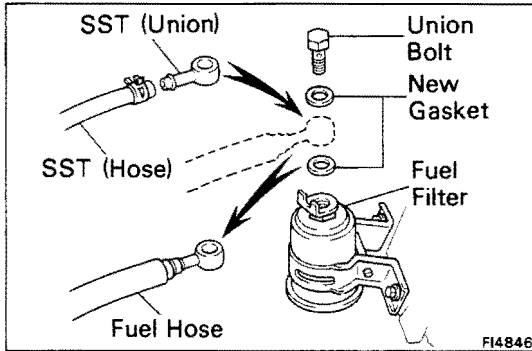
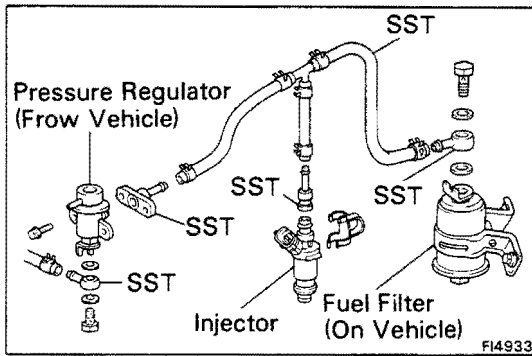

- (a) Disconnect the fuel hose from the fuel filter outlet.
- (b) Connect SST (union and hose) to the fuel filter outlet with two new gaskets and the union bolt.

SST 09268-41045 (90405-09015)

**HINT:** Use the vehicle's fuel filter.

- (c) Install a new O-ring to the fuel inlet of the pressure regulator.
- (d) Connect SST (hose) to the fuel inlet of the pressure regulator with SST (union) and the two bolts.

SST 09268-41045 (09268-41090)

- (e) Connect the fuel return hose to the fuel outlet of the pressure regulator with SST (union), two new gaskets and union bolt.

SST 09268-41045 (09268-41080)

- (f) Install the grommet and a new O-ring to the injector.
- (g) Connect SST (union and hose) to the injector, and hold the injector and union with SST (clamp).

SST 09268-41045

- (h) Put the injector into the graduated cylinder.

**HINT:** Install a suitable vinyl hose onto the injector to prevent gasoline from splashing out.

- (i) Reconnect the battery negative (–) cable.
- (j) Turn the ignition switch ON.

**NOTICE:** Do not start the engine.

- (k) Using SST, connect terminals +B and FP of the check connector.

SST 09843-18020

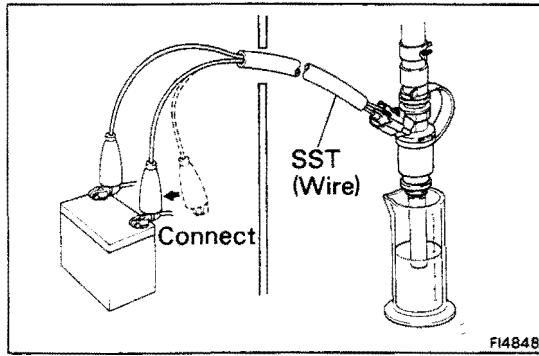

FI4848

- (l) Connect SST (wire) to the injector and battery for 15 seconds, and measure the injection volume with a graduated cylinder.  
Test each injector two or three times.

SST 09842-30070

**Volume: 48 – 58 cc (2.9 – 3.5 cu in.) per 15 sec.**

**Difference between each injector:  
5 cc (0.3 cu in.) or less**

If the injection volume is not as specified, replace the injector.

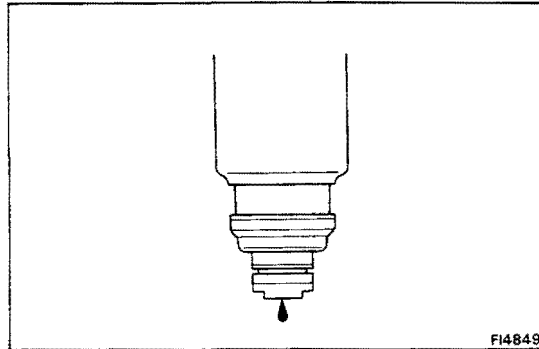

FI4849

**2. INSPECT LEAKAGE**

- (a) In the condition above, disconnect the test probes of SST (wire) from the battery and check the fuel leakage from the injector.

SST 09842-30070

**Fuel drop: One drop or less per minute**

- (b) Disconnect the battery negative (-) cable.
- (c) Remove SST.

SST 09268-41045 and 09843-18020

**INSTALLATION OF INJECTORS**

**1. INSTALL INJECTORS AND DELIVERY PIPE**

- (a) Install a new grommet to the injector.
- (b) Apply a light coat of gasoline to a new O-ring and install it to the injector.

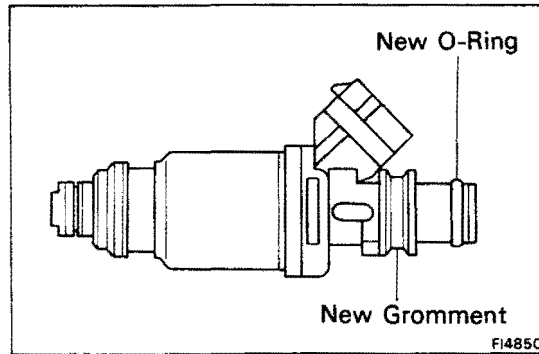

FI4850

- (c) While turning the injector left and right, install it to the delivery pipes. Install the four injectors.

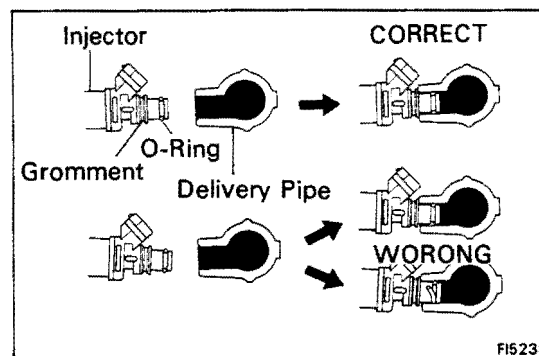

FI5235

- (d) Place the four insulators and two spacers in position on the cylinder head.

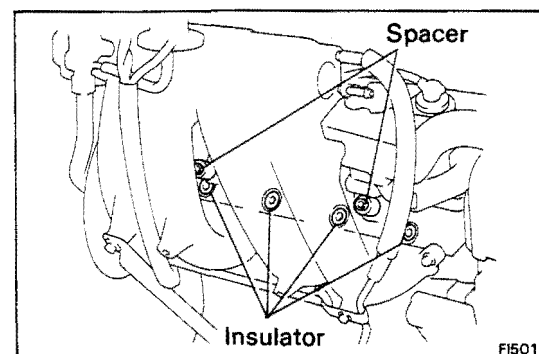

FI5014

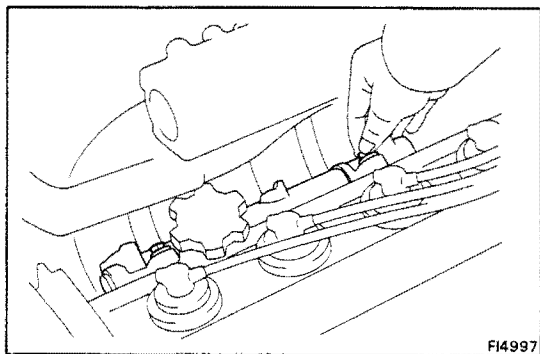

FI4997

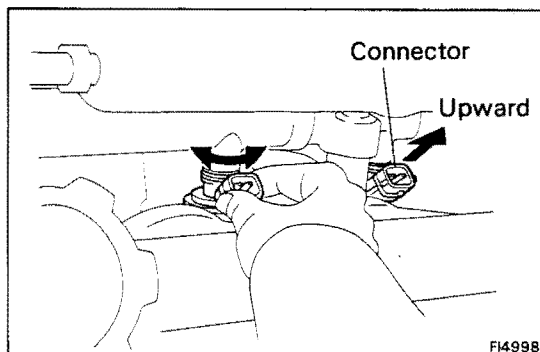

FI4998

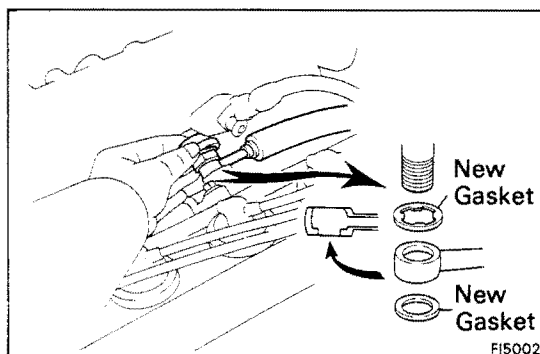

FI5002

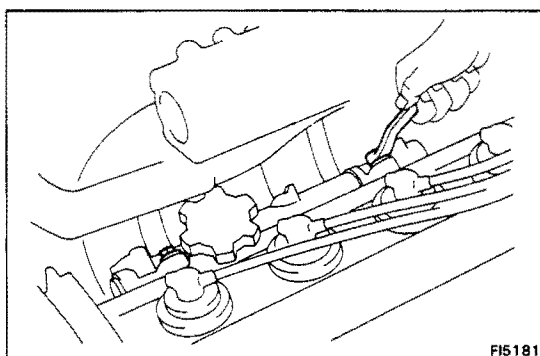

FI5181

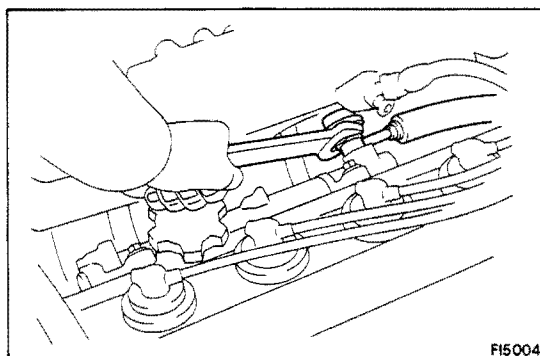

FI5004

- (e) Place the four injectors together with the delivery pipe in position on the cylinder head.
- (f) Temporarily install the two bolts holding the delivery pipe to the cylinder head.
- (g) Check that the injectors rotate smoothly.

**HINT:** If injectors do not rotate smoothly, the probable cause is incorrect installation of O-rings. Replace the O-rings.

- (h) Position the injector connector upward.

- (i) Temporarily connect the fuel inlet hose to the delivery pipe with two new gaskets and the pulsation damper.

- (j) Tighten the two bolts holding the delivery pipe to the cylinder head.

**Torque: 130 kg-cm (9 ft-lb, 13 N·m)**

- (k) Tighten the pulsation damper.

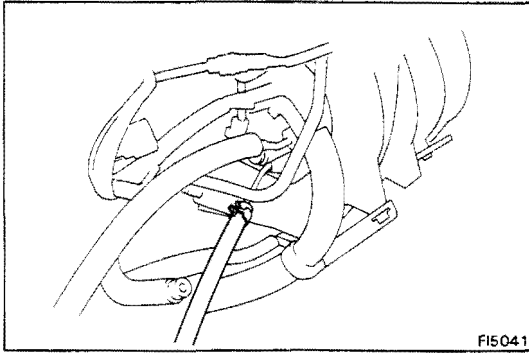

**2. CONNECT FUEL RETURN HOSE TO RETURN PIPE**

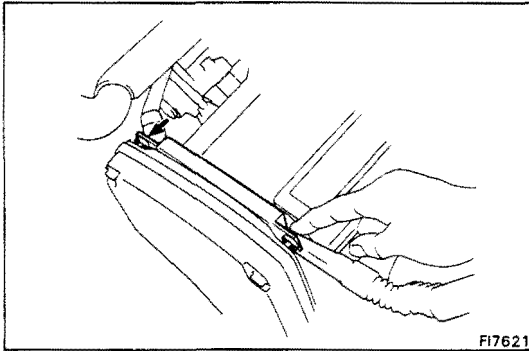

**3. CONNECT ENGINE WIRE**

- (a) Connect the two wire clamps to the wire brackets on the intake manifold.

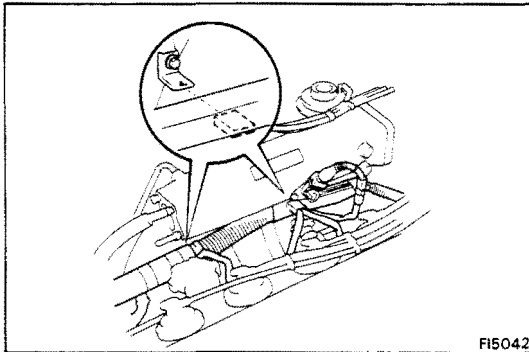

- (b) Connect the two wire clamps to the mount bolts of the No.2 timing belt cover.

**4. CONNECT INJECTOR CONNECTORS**

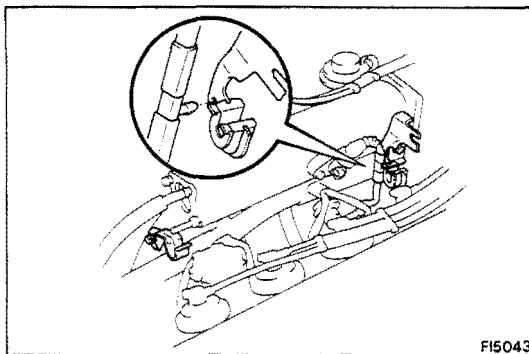

**5. INSTALL ACCELERATOR BRACKETS**

- (a) Remove the RH accelerator bracket with the bolt.  
 (b) Install the LH accelerator bracket with the two bolts. Connect the clip of the engine wire to the LH accelerator bracket.

**6. INSTALL FUEL PRESSURE REGULATOR  
 (See steps 1 to 3 on page FI-128)**

**7. INSTALL COLD START INJECTOR PIPE  
 (See step 2 on page FI-120)**

**8. INSTALL THROTTLE BODY  
 (See steps 2 to 9 on page FI-162)**

**9. CONNECT CABLE TO NEGATIVE TERMINAL OF BATTERY**

**10. CHECK FOR FUEL LEAKAGE (See page FI-11)**

## Injectors (3S-GE)

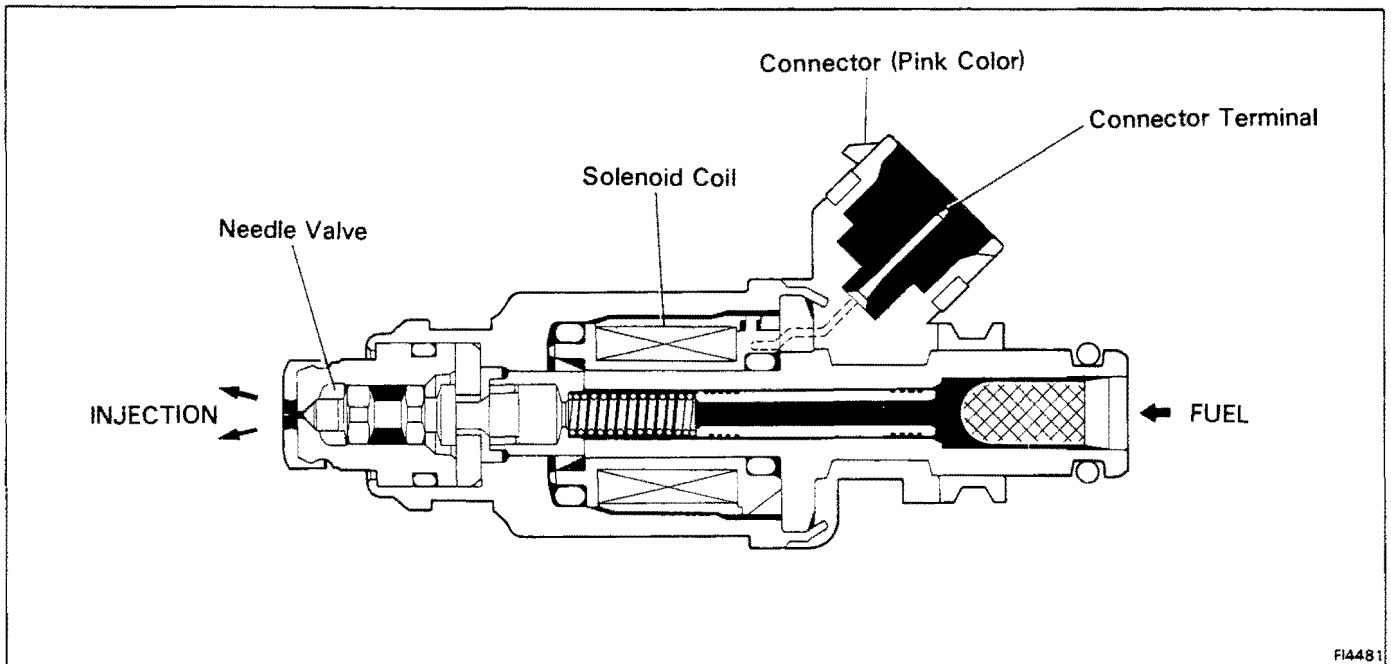

### REMOVAL OF INJECTORS

1. DISCONNECT CABLE FROM NEGATIVE TERMINAL OF BATTERY
2. DRAIN ENGINE COOLANT (See page CO-6)
3. (A/T)  
DISCONNECT THROTTLE CABLE FROM THROTTLE LINKAGE
4. DISCONNECT ACCELERATOR CABLE FROM THROTTLE LINKAGE
5. DISCONNECT AIR CLEANER CAP AND AIR CLEANER HOSE
6. DISCONNECT COLD START INJECTOR PIPE (See step 3 on page FI-121)
7. DISCONNECT HOSES FROM THROTTLE BODY AND AIR INTAKE CHAMBER
  - (a) PCV hose
  - (b) (w/ TWC)  
Vacuum hose from EVAP BVS
  - (c) Water by-pass hose from water outlet
  - (d) Water by-pass hose from water by-pass pipe
  - (e) Vacuum and air hoses from air pipe
  - (f) Brake booster hose from by-pass pipe

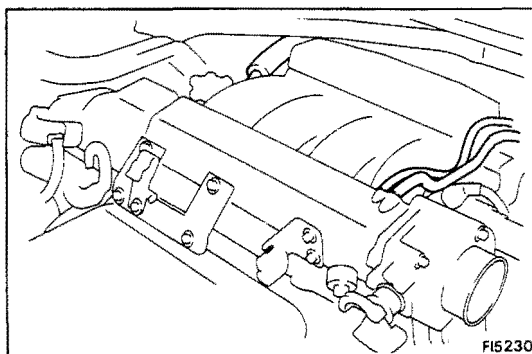
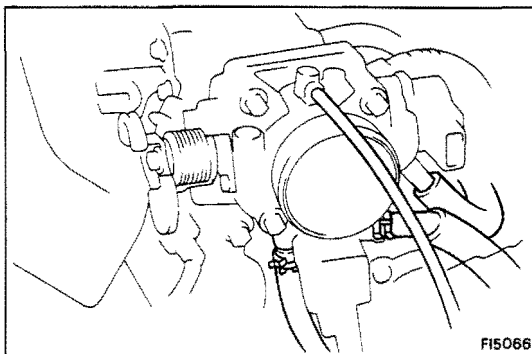

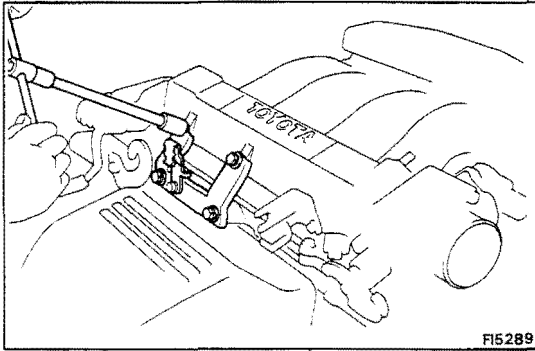

**8. REMOVE AIR INTAKE CHAMBER**

(a) Remove the four bolts and air intake chamber stay.

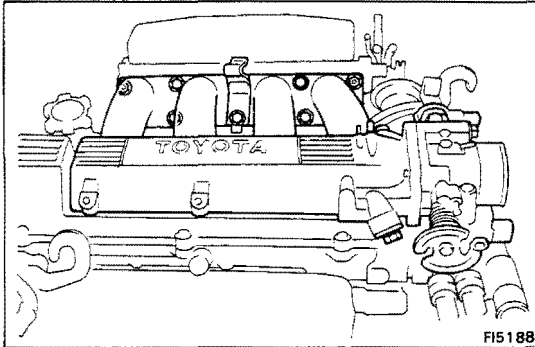

(b) Remove the bolt holding the air intake chamber and intake pipe stay.

(c) Remove the five bolts, two nuts, air intake chamber and gasket.

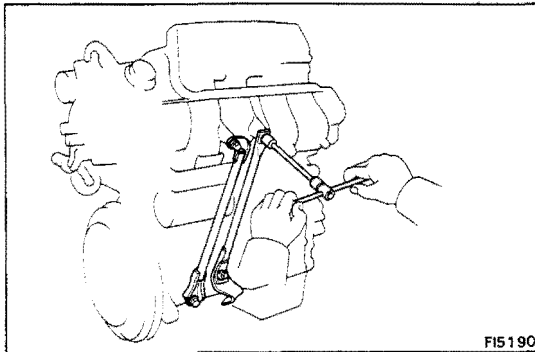
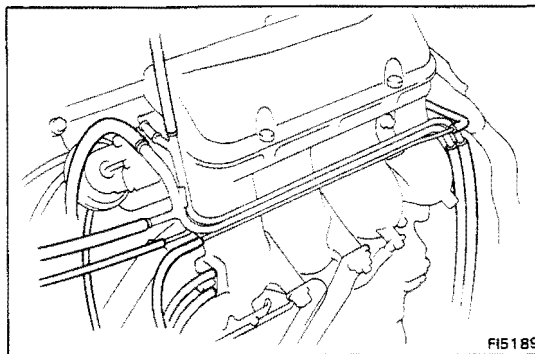
**9. REMOVE INTAKE MANIFOLD STAYS****10. DISCONNECT HOSES FROM AIR PIPE**

- (a) Vacuum hose from pressure regulator
- (b) Vacuum hoses from PS pump
- (c) Vacuum hoses from fuel control VSV
- (d) Vacuum hose from ACIS VSV
- (e) Vacuum hose from vacuum tank
- (f) Vacuum hose from vacuum sensor
- (g) Vacuum hoses from A/C actuator

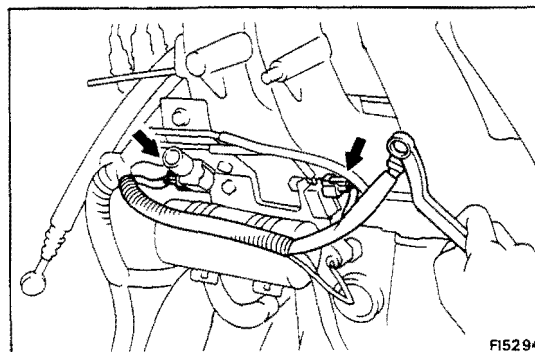
**11. DISCONNECT CONNECTORS AND GRAND STRAP**

- (a) Fuel control VSV
- (b) ACIS VSV
- (c) Grand strap

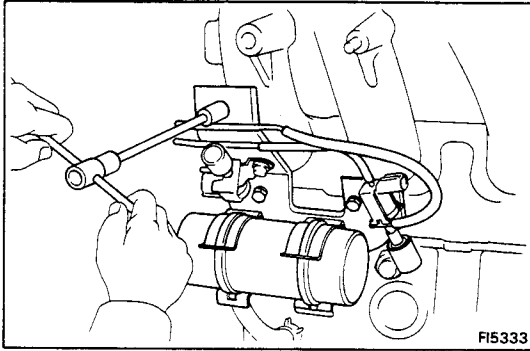
**12. REMOVE AIR CONTROL VALVE ASSEMBLY**

Remove the three bolts and air control valve assembly.

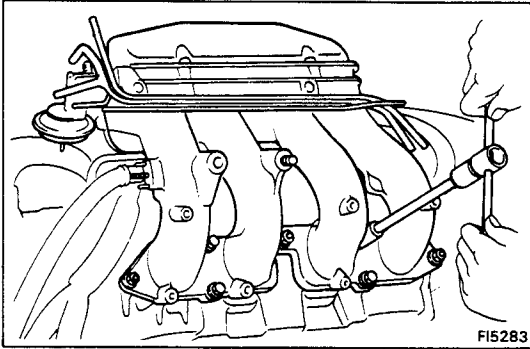
**13. REMOVE INTAKE MANIFOLD**

Remove the four bolts, three nuts, intake manifold and gasket.

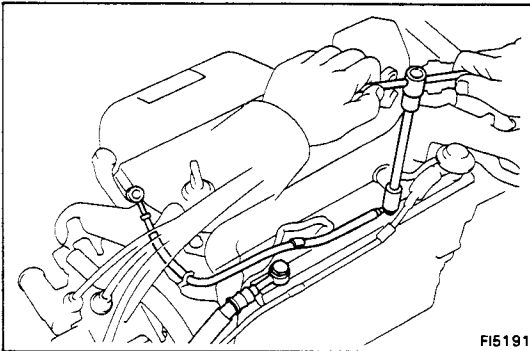
**14. REMOVE COLD START INJECTOR PIPE FROM DELIVERY PIPE**

Remove the union bolt, two gaskets and injector pipe.

**15. DISCONNECT FUEL INLET HOSE FROM DELIVERY PIPE**

Remove the union bolt and two gaskets, and disconnect the fuel inlet hose.

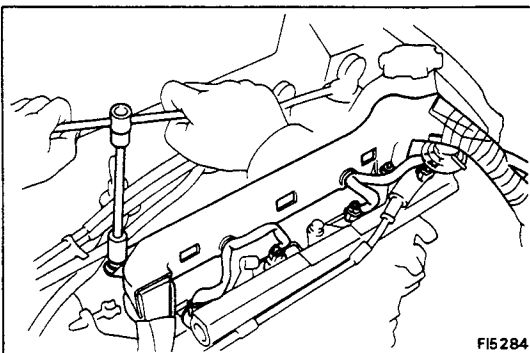
**16. DISCONNECT FOUR INJECTOR CONNECTORS****17. DISCONNECT WIRE HARNESS PROTECTOR**

Remove the two nuts and disconnect the wire harness protector.

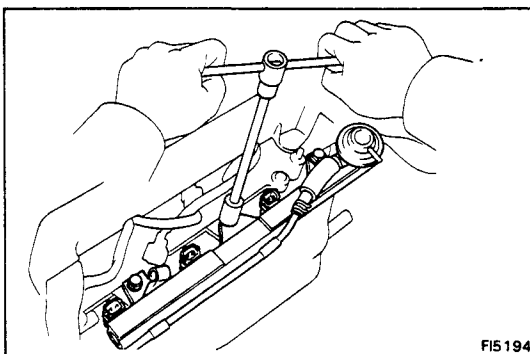
**18. REMOVE DELIVERY PIPE AND INJECTORS**

- (a) Remove the three bolts and delivery pipe together with four injectors.

**NOTICE:** Be careful not to drop the injectors, when removing the delivery pipe.

- (b) Remove the four insulators and three spacers from the cylinder head.  
 (c) Pull out the four injectors from the delivery pipe.

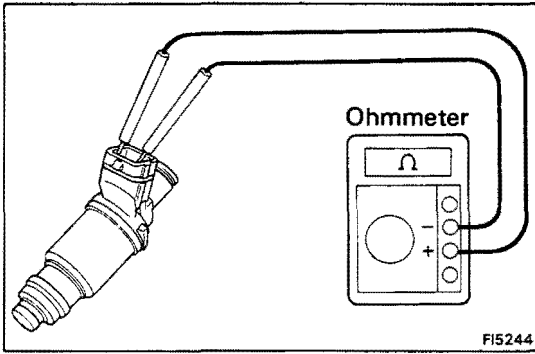

FI5244

## INSPECTION OF INJECTORS

### 1. INSPECT INJECTOR RESISTANCE

Using an ohmmeter, measure the resistance between the terminals.

**Resistance: Approx. 13.8 Ω**

If the resistance is not as specified, replace the injector.

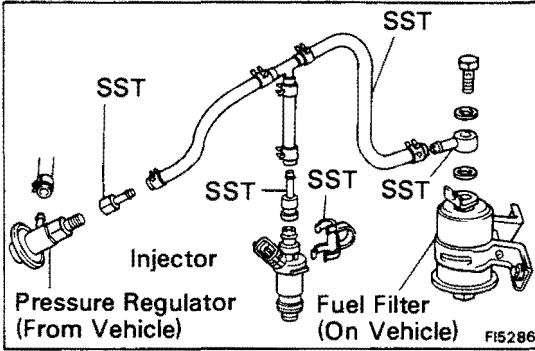

FI5286

### 2. INSPECT INJECTOR INJECTION

**CAUTION:** Keep injector clear of sparks during the test.

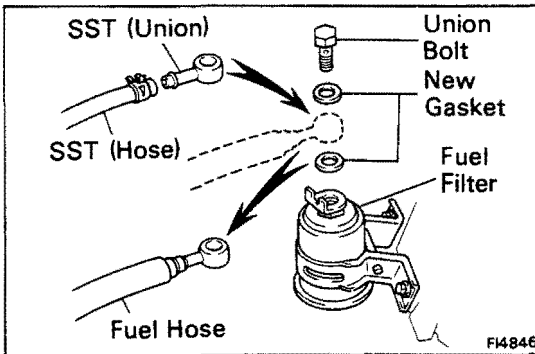

FI4846

- (a) Disconnect the fuel hose from the fuel filter outlet.
- (b) Connect SST (union and hose) to the fuel filter outlet with two new gaskets and the union bolt.

SST 09268-41045 (90405-09015)

**HINT:** Use the vehicle's fuel filter.

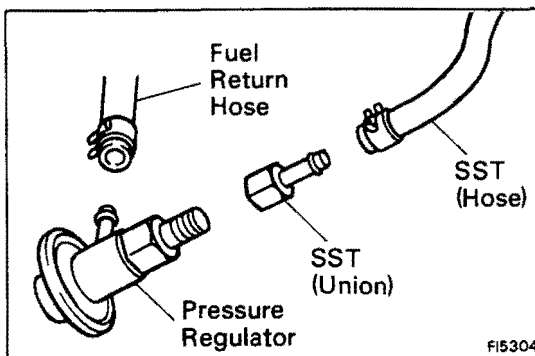

FI5304

- (c) Remove the fuel pressure regulator. (See step 6 on page FI-132)
- (d) Install a new O-ring to the fuel inlet of the pressure regulator.
- (e) Connect SST (hose) to the fuel inlet of the pressure regulator with SST (union).

SST 09268-41045 (09268-41060)

- (f) Connect the fuel return hose to the fuel outlet of the pressure regulator.

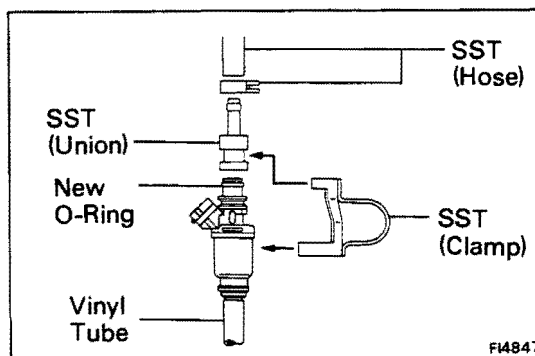

FI4847

- (g) Install the grommet and a new O-ring to the injector.
- (h) Connect SST (union and hose) to the injector, and hold the injector and union with SST (clamp).

SST 09268-41045

- (i) Put the injector into the graduated cylinder.

**HINT:** Install a suitable vinyl hose onto the injector to prevent gasoline from splashing out.

- (j) Reconnect the battery negative (-) cable.
- (k) Turn the ignition switch ON.

**NOTICE:** Do not start the engine.

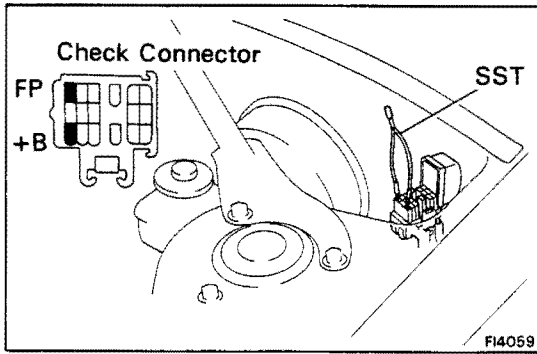

- (l) Using SST, connect terminals +B and FP of the check connector.

SST 09843-18020

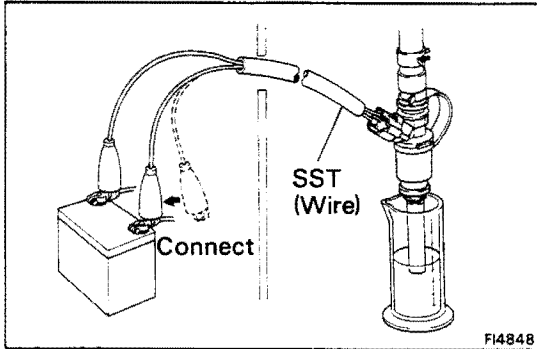

- (m) Connect SST (wire) to the injector and battery for 15 seconds, and measure the injection volume with a graduated cylinder. Test each injector two or three times.

SST 09842-30070

**Volume: 66 – 82 cc (4.0 – 5.0 cu in.) per 15 sec.**

**Difference between each injector:  
5 cc (0.3 cu in.) or less**

If the injection volume is not as specified, replace the injector.

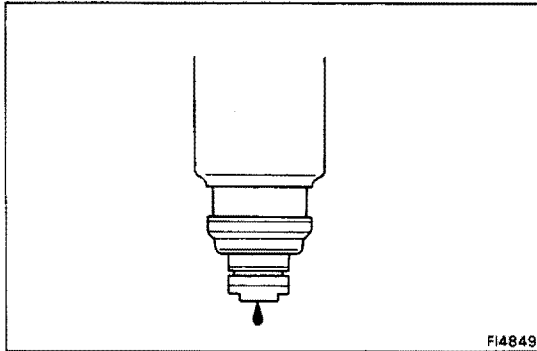

**3. INSPECT LEAKAGE**

- (a) In the condition above, disconnect the test probes of SST (wire) from the battery and check the fuel leakage from the injector.

SST 09842-30070

**Fuel drop: One drop or less per minute**

- (b) Disconnect the battery negative (–) cable.
- (c) Remove SST.

SST 09268-41045 and 09843-18020

**INSTALLATION OF INJECTORS**

**1. INSTALL INJECTORS AND DELIVERY PIPE**

- (a) Install a new grommet to the injector.
- (b) Apply a light coat of gasoline to a new O-ring and install it to the injector.

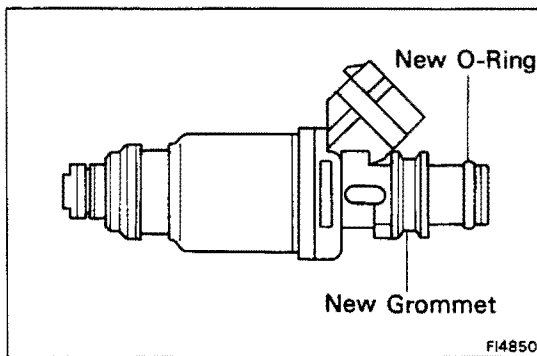

- (c) While turning the injector left and right, install it to the delivery pipes. Install the four injectors.

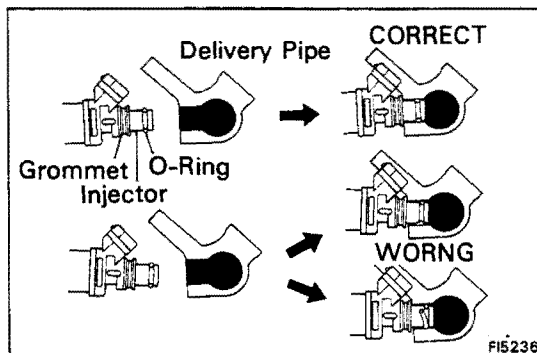

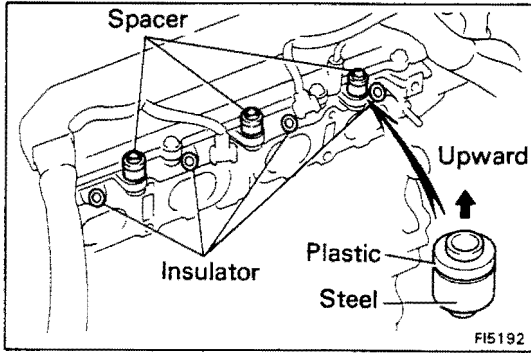

- (d) Place the four insulators and three spacers in position on the cylinder head.

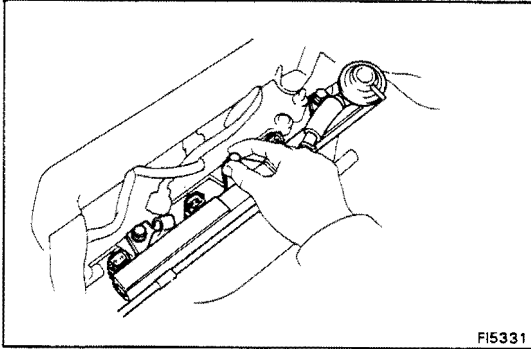

- (e) Place the four injectors together with the delivery pipe in position on the cylinder head.  
 (f) Temporarily install the three bolts holding the delivery pipe to the cylinder head.

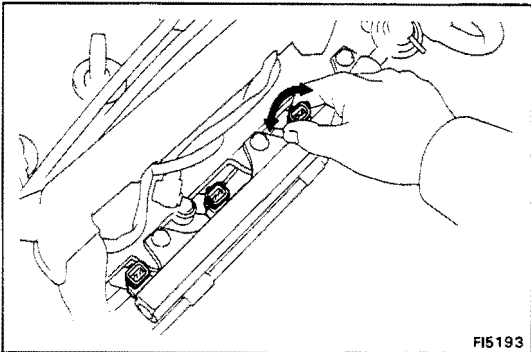

- (g) Check that the injectors rotate smoothly.  
**HINT:** If injectors do not rotate smoothly, the probable cause is incorrect installation of O-rings. Replace the O-rings.  
 (h) Position the injection connector upward.

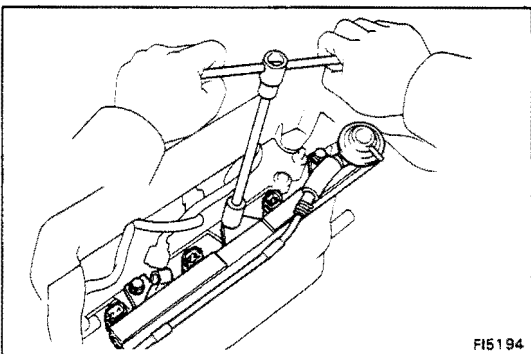

- (i) Install and tighten the three bolts holding the delivery pipe to the cylinder head.

**Torque: 195 kg-cm (14 ft-lb, 19 N·m)**

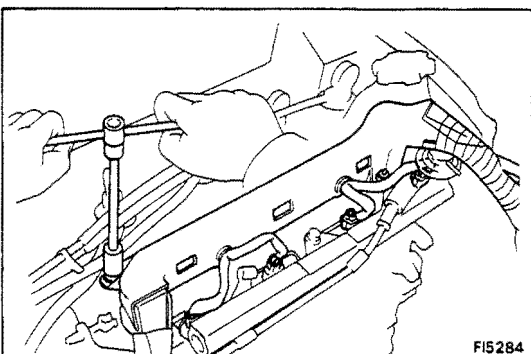

## 2. CONNECT WIRE HARNESS PROTECTOR

Connect the wire harness protector with the two nuts.

## 3. CONNECT FOUR INJECTOR CONNECTORS

**NOTICE:** Take care to not connect the connectors to the wrong cylinder, particularly with cylinders No.1 and No.2, and cylinders No.3 and No.4.

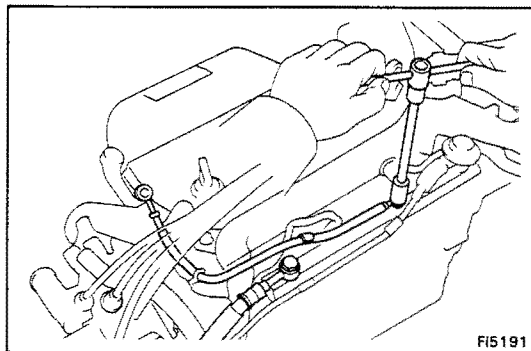

- 4. CONNECT FUEL INLET HOSE TO DELIVERY PIPE**  
 Connect the fuel inlet hose with the union bolt and two new gaskets.

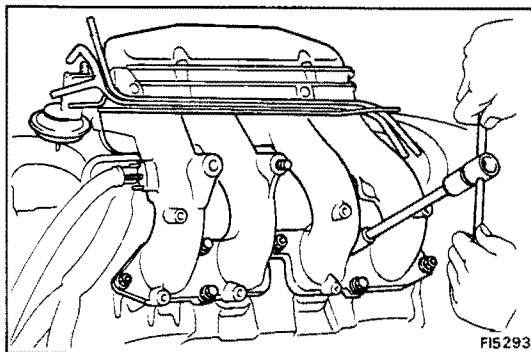

- 5. INSTALL COLD START INJECTOR PIPE**  
 Install the cold start injector pipe with union bolt and two new gaskets.

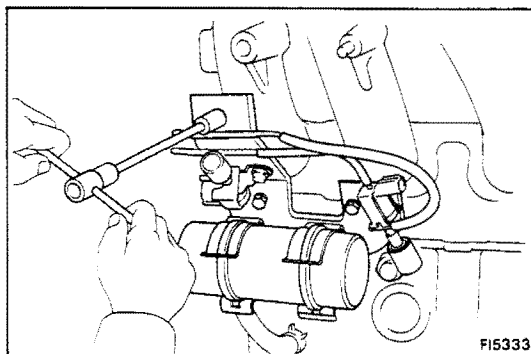

- 6. INSTALL INTAKE MANIFOLD**  
 Install a new gasket and the intake manifold with the four bolts and three nuts.  
 Torque: 195 kg-cm (14 ft-lb, 19 N·m)

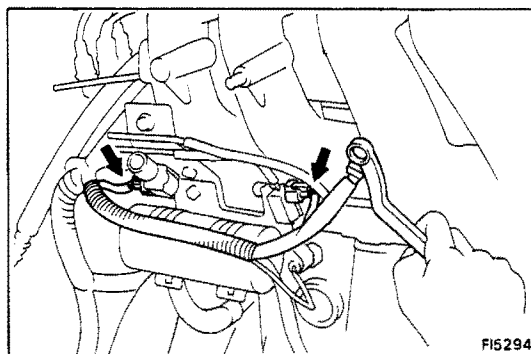

- 7. INSTALL AIR CONTROL VALVE ASSEMBLY**  
 Install the air control valve with the three bolts.

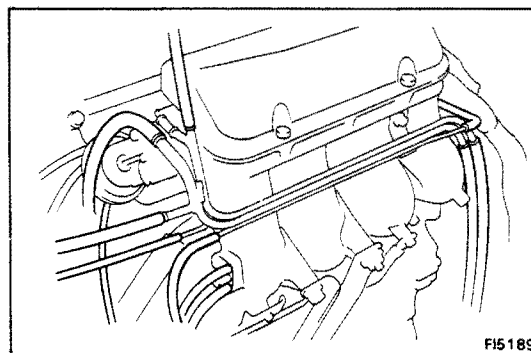

- 8. CONNECT CONNECTORS AND GRAND STRAP**
- (a) Fuel control VSV
  - (b) ACIS VSV
  - (c) Grand strap
- 9. CONNECT HOSES TO AIR PIPE**
- (a) Vacuum hose from pressure regulator
  - (b) Vacuum hoses from PS pump
  - (c) Vacuum hoses from fuel control VSV
  - (d) Vacuum hose from ACIS VSV
  - (e) Vacuum hose from vacuum tank
  - (f) Vacuum hose from vacuum sensor
  - (g) Vacuum hoses from A/C actuator

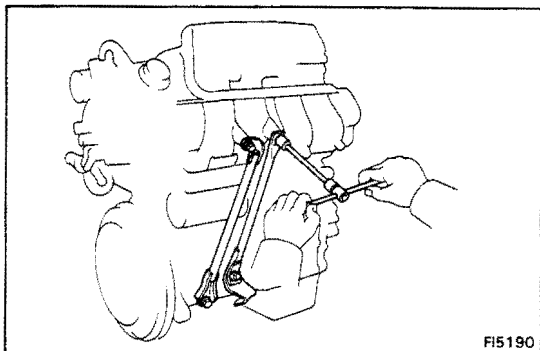

FI5190

**10. INSTALL INTAKE MANIFOLD STAYS**

Install the two intake manifold stays with the two bolts and nuts.

**Torque: 400 kg-cm (29 ft-lb, 39 N·m)**

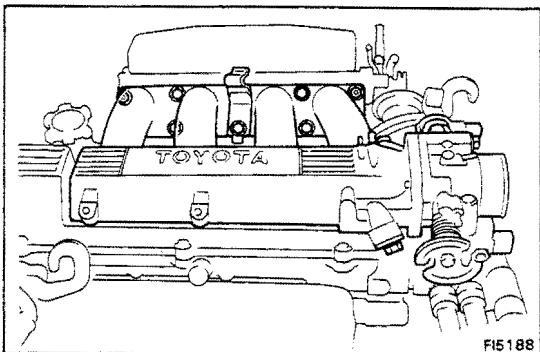

FI5188

**11. INSTALL AIR INTAKE CHAMBER**

(a) Install a new gasket, air intake chamber with the five bolts and two nuts.

**Torque: 195 kg-cm (14 ft-lb, 19 N·m)**

(b) Install and tighten the bolt holding the air intake chamber and intake pipe stay.

**Torque: 400 kg-cm (29 ft-lb, 39 N·m)**

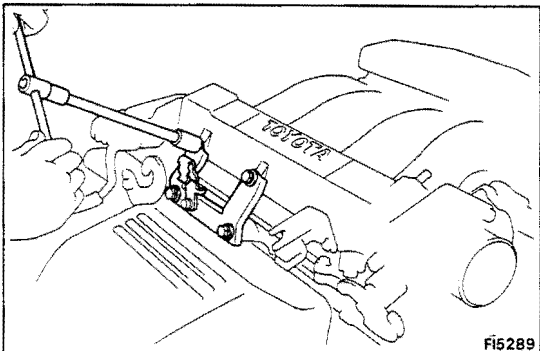

FI5289

(c) Install the intake chamber stay with the four bolts.

**Torque: 195 kg-cm (14 ft-lb, 19 N·m)**

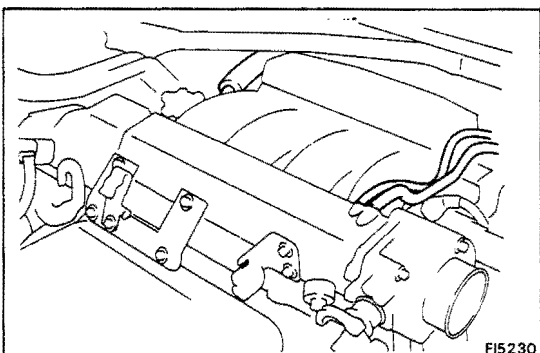

FI5230

**12. CONNECT HOSES TO THROTTLE BODY AND AIR INTAKE CHAMBER**

(a) Vacuum and air hoses from air pipe

(b) Brake booster hose from by-pass pipe

(c) PCV hose

(d) (w/ TWC)

Vacuum hose from EVAP BVSV

(e) Water by-pass hose from water outlet

(f) Water by-pass hose from water by-pass pipe

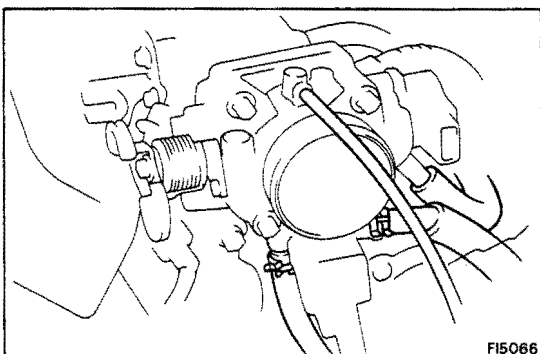

FI5066

- 13. CONNECT COLD START INJECTOR PIPE  
(See step 2 on page FI-123)**
- 14. CONNECT AIR CLEANER CAP AND AIR CLEANER HOSE**
- 15. CONNECT ACCELERATOR CABLE, AND ADJUST IT**
- 16. (A/T)  
CONNECT THROTTLE CABLE, AND ADJUST IT**
- 17. FILL WITH ENGINE COOLANT (See page CO-6)**
- 18. CONNECT CABLE TO NEGATIVE TERMINAL OF BATTERY**
- 19. CHECK FOR FUEL LEAKAGE (See page FI-11)**



## Injectors (3S-GTE)

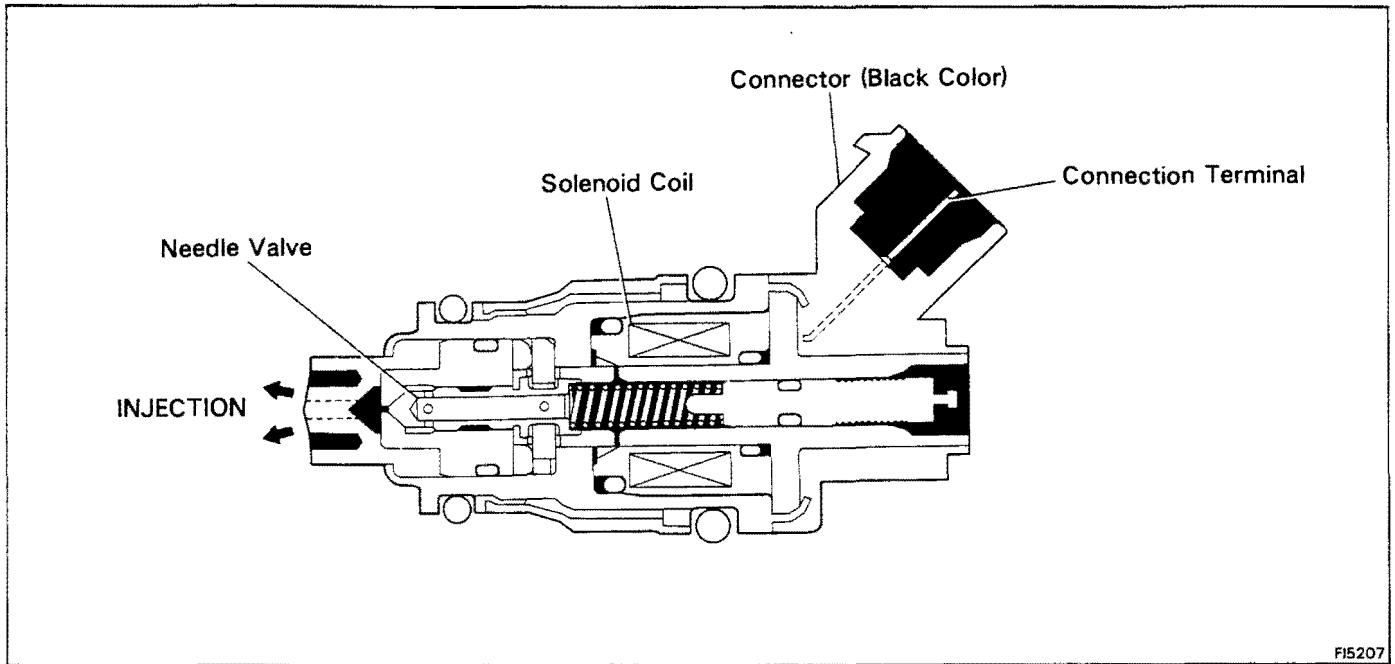

FI5207

### REMOVAL OF INJECTORS

1. **REMOVE THROTTLE BODY**  
(See steps 1 to 10 on pages FI-170, 171)
2. **REMOVE COLD START INJECTOR PIPE**  
(See step 3 on page FI-124)
3. **REMOVE INTAKE MANIFOLD AND T-VIS VALVE**  
(See steps 20 to 23 on page EM-112, 113)
4. **DISCONNECT INJECTOR CONNECTORS**
5. **DISCONNECT FUEL INLET HOSE FROM DELIVERY PIPE**
  - (a) Remove the union bolt and two gaskets.
  - (b) Remove the bolt and disconnect the fuel inlet hose.
6. **DISCONNECT FUEL RETURN HOSE FROM PRESSURE REGULATOR**
7. **REMOVE DELIVERY PIPE AND INJECTORS**
  - (a) Remove the three bolts and delivery pipe together with the four injectors.
  - (b) Remove the three spacers from the cylinder head.
  - (c) Remove the four insulators from the delivery pipe.

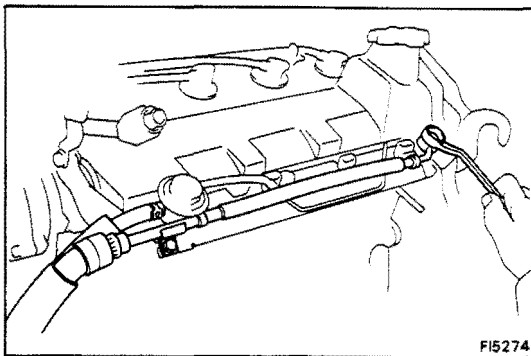

FI5274

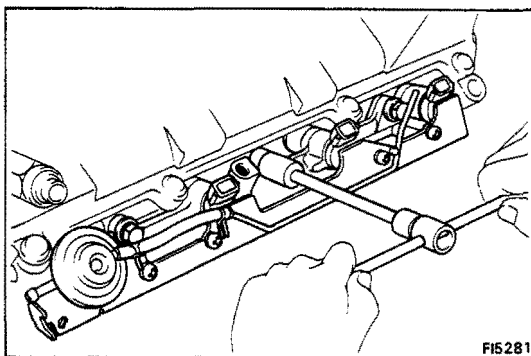

FI5281

## INSPECTION OF INJECTORS

### 1. INSPECT INJECTOR RESISTANCE

Using an ohmmeter, measure the resistance between the terminals.

**Resistance:** 2 – 4 Ω

If the resistance is not as specified, replace the injector.

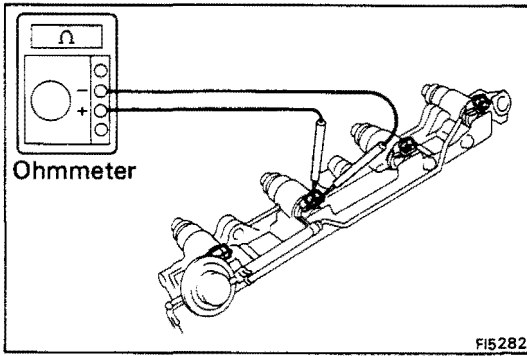

### 2. INSPECT INJECTOR INJECTION

**CAUTION:** Keep injector clear of sparks during the test.

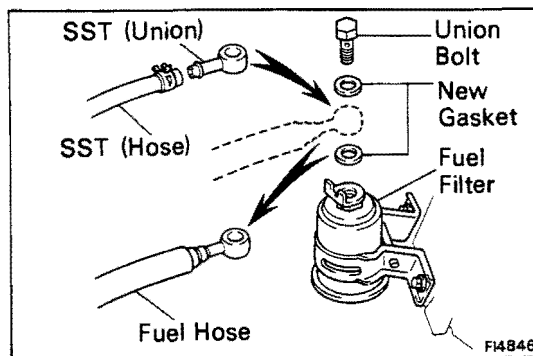
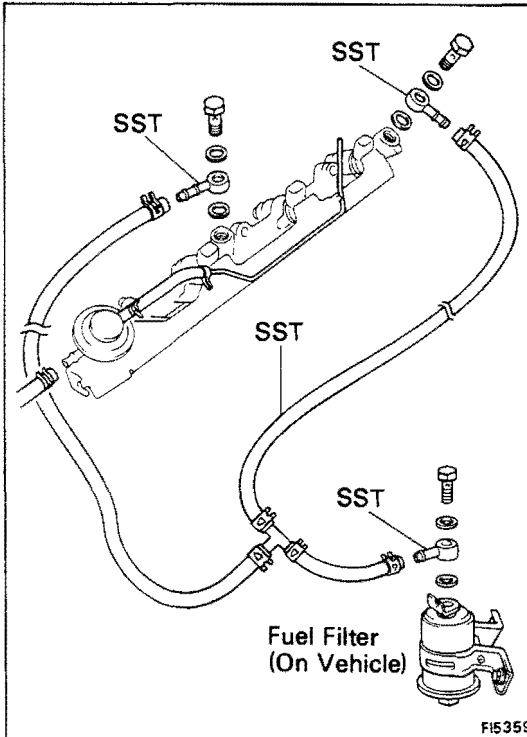

- (a) Disconnect the fuel hose from the fuel filter outlet.
- (b) Connect SST (union and hose) to the fuel filter outlet with two new gaskets and the union bolt.

SST 09268-41045 (09405-09015)

HINT: Use the vehicle's fuel filter.

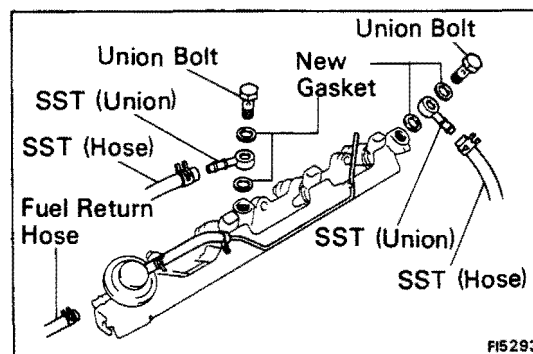

- (c) Install SST (unions) and hoses to the delivery pipe. SST 09268-41045 (09268-41080, 90405-09015)
- (d) Connect the fuel return hose to the pressure regulator.
- (e) Connect SST (hose) to the two unions.
- (f) Put the injector into the graduated cylinder.
- (g) Reconnect the battery negative (–) cable.
- (h) Turn the ignition switch ON.

**NOTICE:** Do not start the engine.

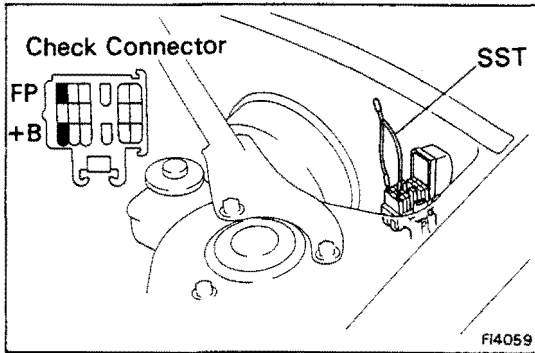

- (i) Using SST, connect terminals +B and FP of the check connector.

SST 09843-18020

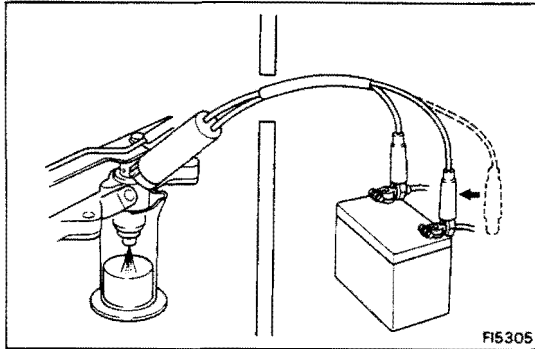

- (j) Connect SST (wire) to the injector and battery for 15 seconds, and measure the injection volume with a graduated cylinder.  
Test each injector two or three times.

SST 09842-30060

**Volume: 101 – 114 cc (6.2 – 7.0 cu in.) per 15 sec.**

**Difference between each injector:**

**5 cc (0.3 cu in.) or less**

If the injection volume is not as specified, replace the injector.

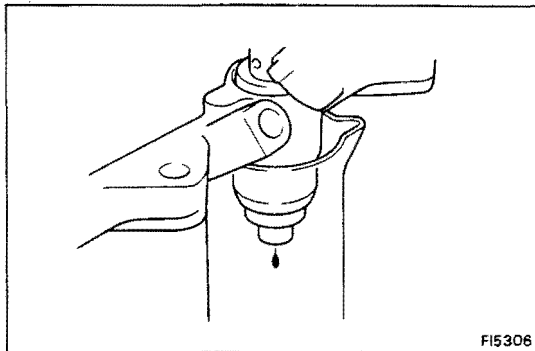

**3. INSPECT LEAKAGE**

- (a) In the condition above, disconnect the test probes of SST (wire) from the battery and check the fuel leakage from the injector.

SST 09842-30060

**Fuel drop: One drop or less per minute.**

- (b) Disconnect the battery negative (-) cable.

- (c) Remove SST.

SST 09268-41045 and 09843-18020

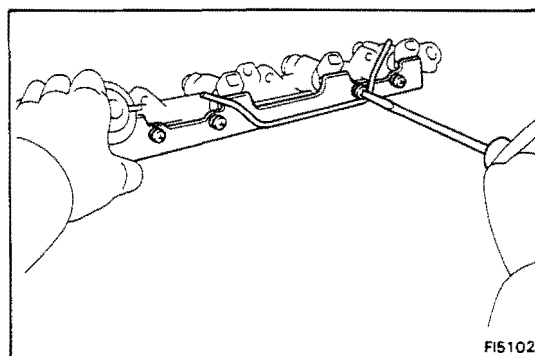

**4. IF NECESSARY, REPLACE INJECTORS**

- (a) Remove the four screws, injector cover and four insulators.

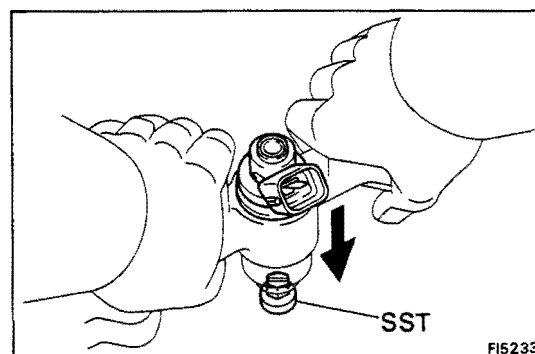

- (b) Using SST, remove the injector from the delivery pipe.

SST 09268-74010

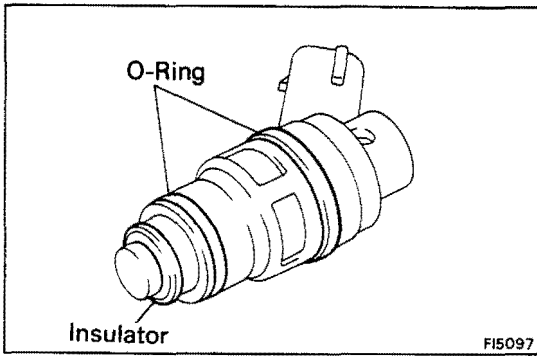

- (c) Apply a light coat of gasoline to two new O-rings and install them to the injector.
- (d) Install a new insulator to the injector.

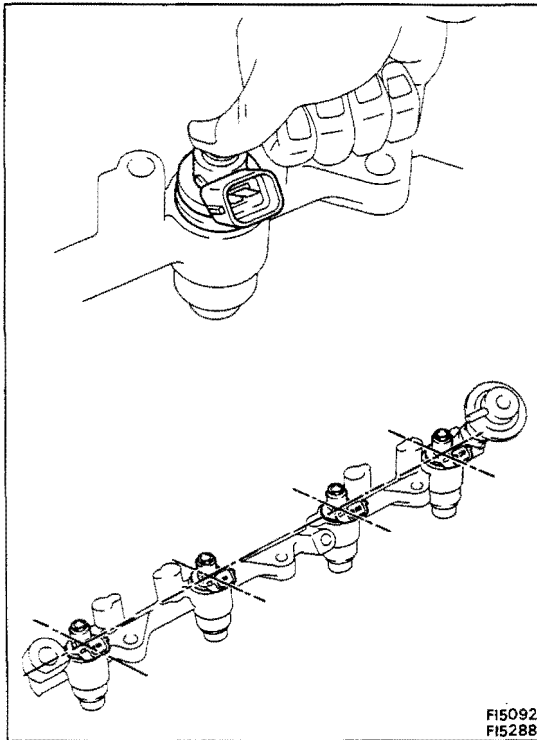

- (e) Push the injector so that injector connector is positioned as shown in the illustration.

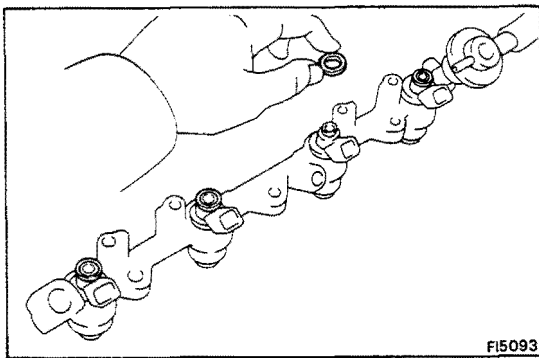

- (f) Install a new insulator to the injector.

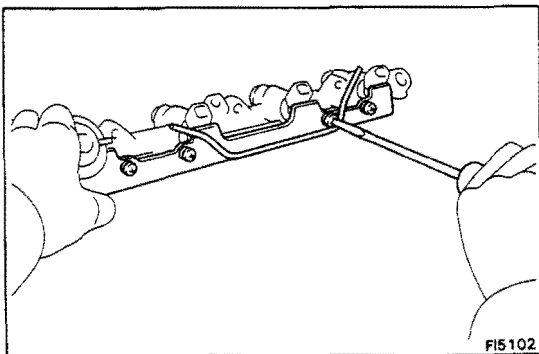

- (g) Install the injector cover with the four screws.

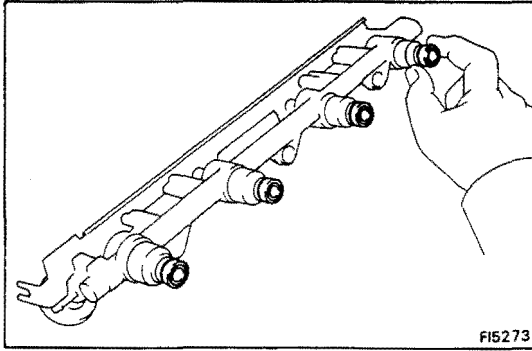

FI5273

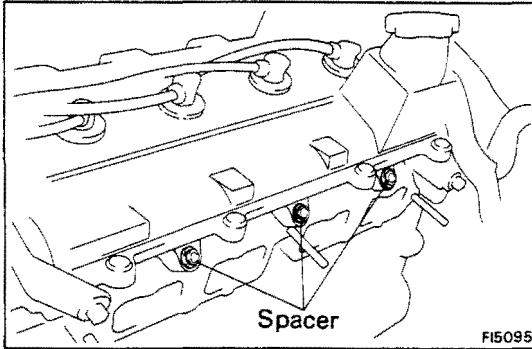

FI5095

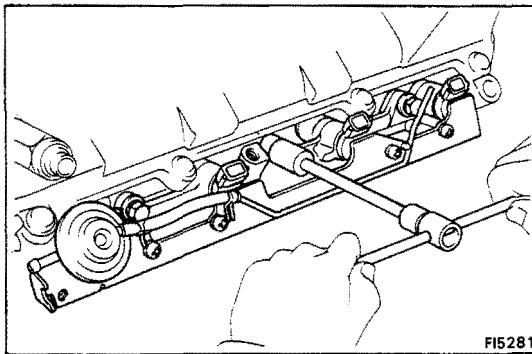

FI5281

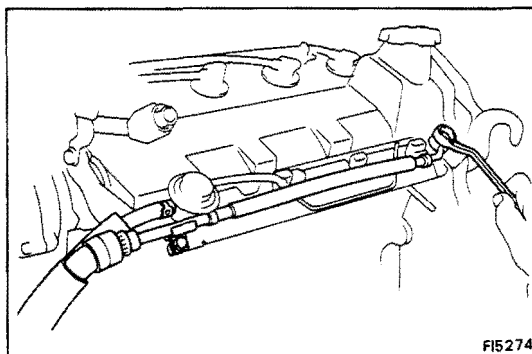

FI5274

## INSTALLATION OF INJECTORS

### 1. INSTALL INJECTORS AND DELIVERY PIPE

- (a) Install four new insulators to the delivery pipe.
- (b) Place the three spacers in position on the cylinder head.
- (c) Place the four injectors together with the delivery pipe in position on the cylinder head.
- (d) Install the three bolts holding the delivery pipe to the cylinder head.

**Torque: 195 kg-cm (14 ft-lb, 19 N·m)**

### 2. CONNECT FUEL INLET HOSE TO DELIVERY PIPE

- (a) Connect the fuel inlet hose to the delivery pipe with the union bolt.
- Torque: 300 kg-cm (22 ft-lb, 29 N·m)**
- (b) Install the fuel inlet hose clamp bolt.

### 3. CONNECT FUEL RETURN HOSE TO PRESSURE REGULATOR

### 4. CONNECT INJECTOR CONNECTORS

### 5. INSTALL T-VIS VALVE AND INTAKE MANIFOLD (See steps 10 to 13 on pages EM-141, 142)

### 6. INSTALL COLD START INJECTOR PIPE (See step 2 on page FI-126)

### 7. INSTALL THROTTLE BODY (See steps 2 to 12 on pages FI-171, 172)

# AIR INDUCTION SYSTEM

## Air Flow Meter (3S-GTE only)

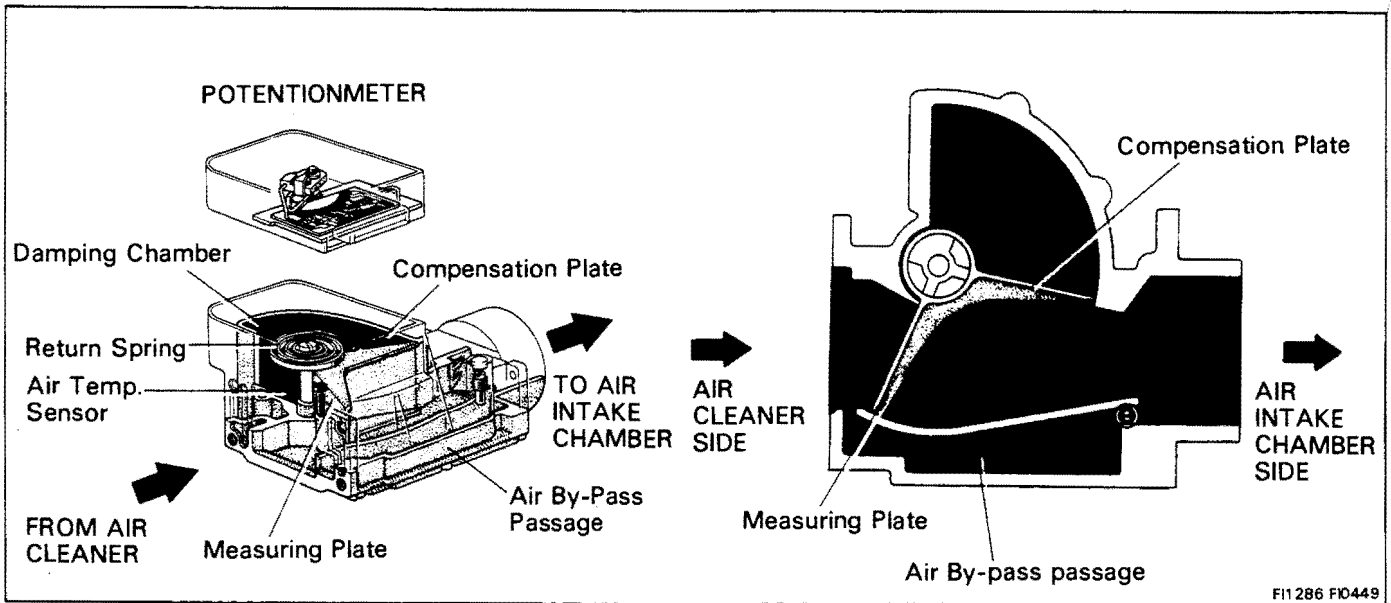

FI1286 FI0449

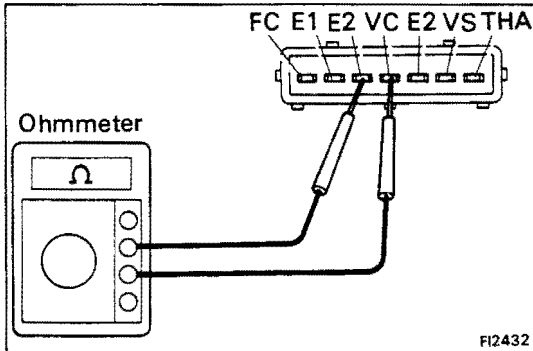

FI2432

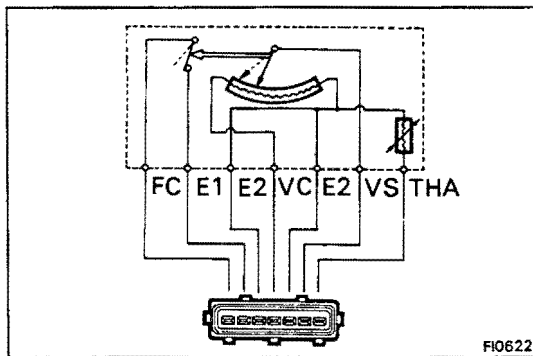

FI0622

### ON-VEHICLE INSPECTION

#### INSPECT RESISTANCE OF AIR FLOW METER

- Disconnect the air flow meter connector.
- Using an ohmmeter, measure the resistance between each terminal.

Between terminals	Resistance ( $\Omega$ )	Temp. $^{\circ}\text{C}$ ( $^{\circ}\text{F}$ )
E2 - VS	200 - 600	-
E2 - VC	200 - 400	-
E2 - THA	10,000 - 20,000	-20 (-4)
	4,000 - 7,000	0 (32)
	2,000 - 3,000	20 (68)
	900 - 1,300	40 (104)
	400 - 700	60 (140)
E1 - FC	Infinity	-

If the resistance is not as specified, replace the air flow meter.

- Reconnect the air flow meter connector.

### REMOVAL OF AIR FLOW METER

- DISCONNECT AIR FLOW METER CONNECTOR
- DISCONNECT ACCELERATOR CABLE
- DISCONNECT AIR CLEANER HOSE
- REMOVE AIR CLEANER CAP AND AIR FLOW METER ASSEMBLY

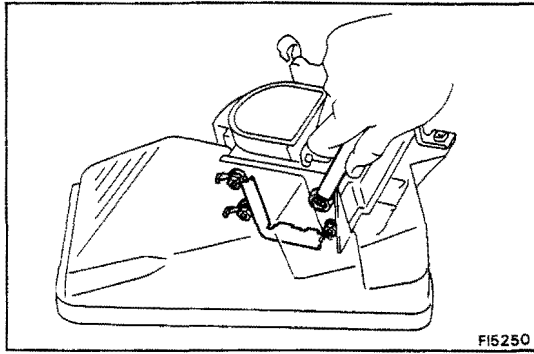

**5. REMOVE AIR FLOW METER FROM AIR CLEANER CAP**

Pry off the lock plates, and remove the bolt, four nuts, four plates, air flow meter and gasket.

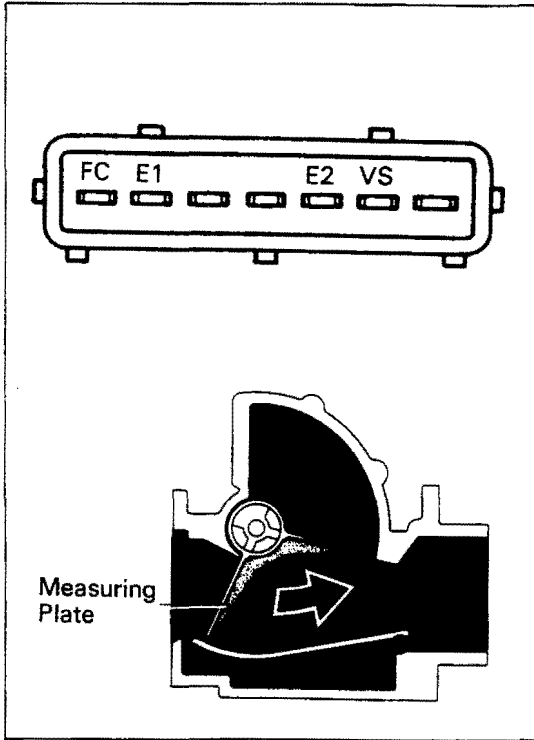

**INSPECTION OF AIR FLOW METER**

**INSPECT RESISTANCE OF AIR FLOW METER**

Using an ohmmeter, measure the resistance between each terminal by moving the measuring plate.

Between terminals	Resistance ( $\Omega$ )	Measuring plate opening
E2 - VS	200 - 600	Fully closed
	20 - 1,200	Fully open

**HINT:** Resistance between terminals E2 and VS will change in a wave pattern as the measuring plate slowly opens.

If the resistance is not as specified, replace the meter.

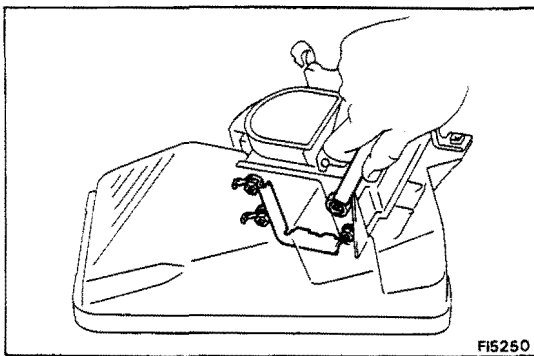

**INSTALLATION OF AIR FLOW METER**

**1. INSTALL AIR FLOW METER TO AIR CLEANER CAP**

Install the air flow meter with the gasket, lock plate, four plate washers, four nuts and bolt. Pry the lock plate on the nut.

**2. INSTALL AIR CLEANER CAP AND AIR FLOW METER ASSEMBLY**

**3. CONNECT AIR CLEANER HOSE**

**4. CONNECT ACCELERATOR CABLE TO CLAMP**

**5. CONNECT AIR FLOW METER CONNECTOR**

# Throttle Body (5S-FE w/o ECT)

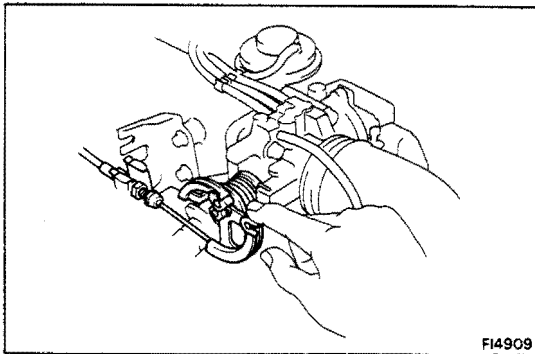
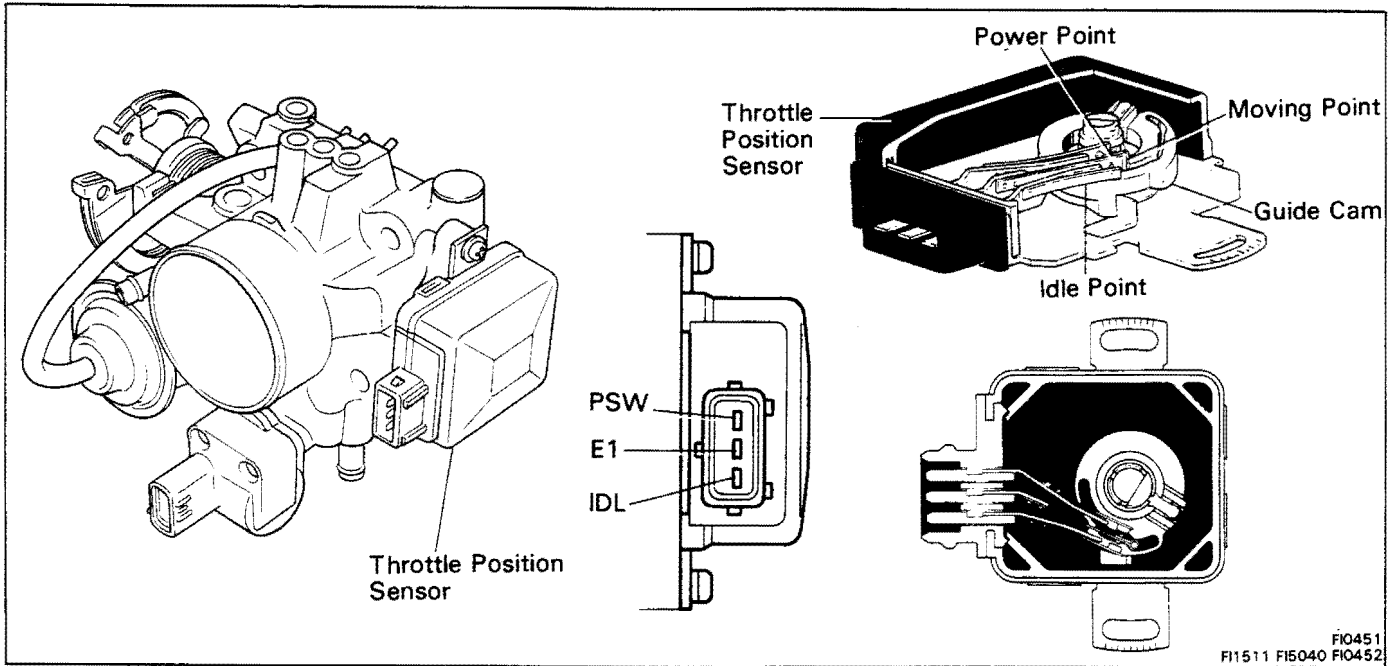

## ON-VEHICLE INSPECTION

### 1. INSPECT THROTTLE BODY

(a) Check that the throttle linkage moves smoothly.

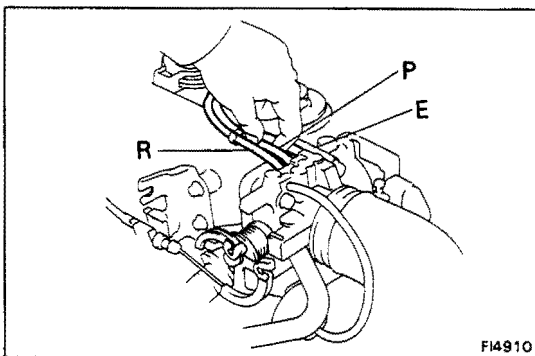

(b) Check the vacuum at each port.

- Start the engine.
- Check the vacuum with your finger.

Port name	At idling	Other than idling
P	No vacuum	Vacuum
E	No vacuum	Vacuum
R	No vacuum	No vacuum

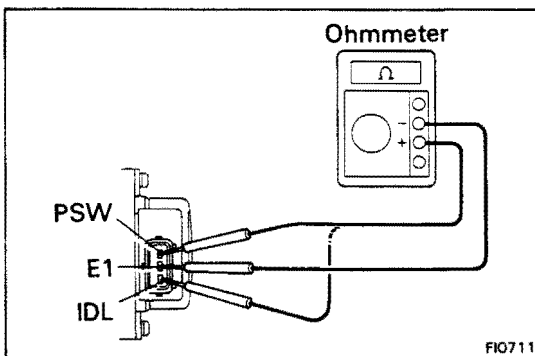

### 2. INSPECT THROTTLE POSITION SENSOR

- (a) Apply vacuum to the throttle opener.
- (b) Disconnect the sensor connector.
- (c) Insert a thickness gauge between the throttle stop screw and stop lever.
- (d) Using an ohmmeter, measure the resistance between each terminal.



Clearance between lever and stop screw	Continuity between terminals	
	IDL – E1	PSW – E1
0.50 mm (0.020 in.)	Continuity	No continuity
0.90 mm (0.035 in.)	No continuity	No continuity
Throttle valve fully opened	No continuity	Continuity

(e) Reconnect the sensor connector.

**3. INSPECT THROTTLE OPENER**

**A. Warm up engine**

Allow the engine to reach normal operating temperature.

**B. Check idle speed**

**Idle speed: 700 ± 50 rpm**

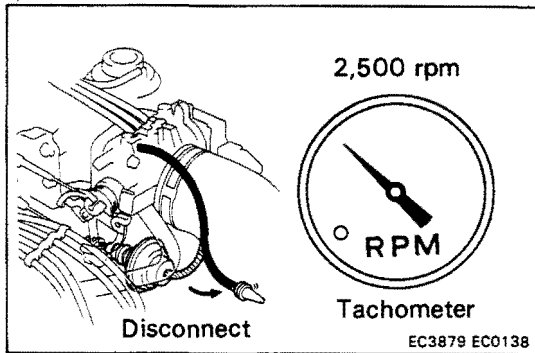

**C. Check and adjust throttle opener setting speed**

(a) Disconnect the vacuum hose from the throttle opener, and plug the hose end.

(b) Maintain the engine at 2,500 rpm.

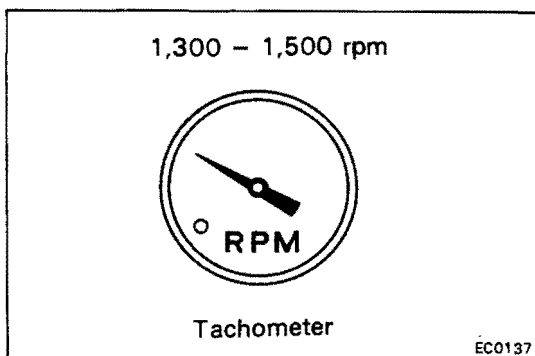

(c) Release the throttle valve.

(d) Check that the throttle opener is set.

**Throttle opener setting speed: 1,300 – 1,500 rpm (w/ Cooling fan OFF)**

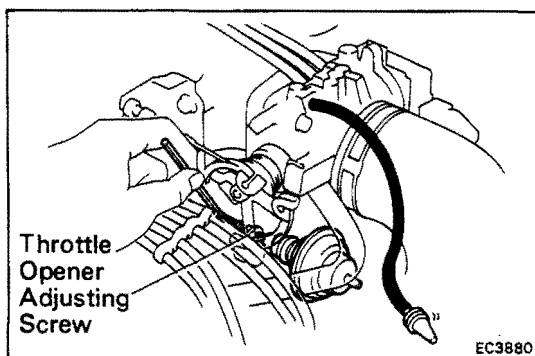

(e) Using a hexagon wrench, adjust the throttle opener setting speed by turning the throttle opener adjusting screw.

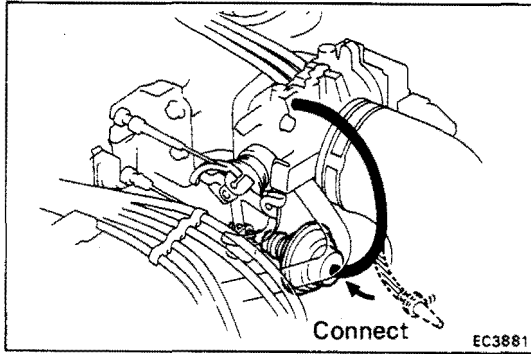

(f) Reconnect the vacuum hose to the throttle opener.

## REMOVAL OF THROTTLE BODY

1. DISCONNECT CABLE FROM NEGATIVE TERMINAL OF BATTERY
2. DRAIN ENGINE COOLANT (See page CO-6)
3. (A/T)  
DISCONNECT THROTTLE CABLE FROM THROTTLE LINKAGE
4. DISCONNECT ACCELERATOR CABLE FROM THROTTLE LINKAGE
5. REMOVE AIR CLEANER CAP AND AIR CLEANER HOSE
6. DISCONNECT THROTTLE POSITION SENSOR CONNECTOR
7. DISCONNECT ISC VALVE CONNECTOR

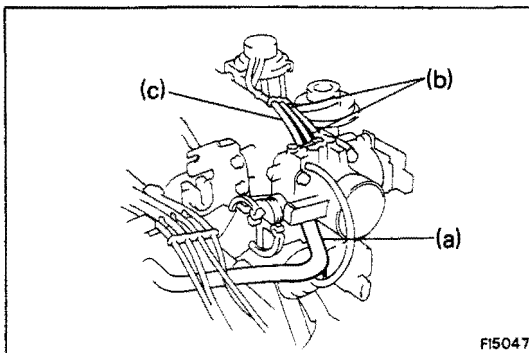

### 8. DISCONNECT HOSES FROM THROTTLE BODY

- (a) PCV hose
- (b) Two vacuum hoses from EGR vacuum modulator
- (c) Vacuum hose from EVAP BSV

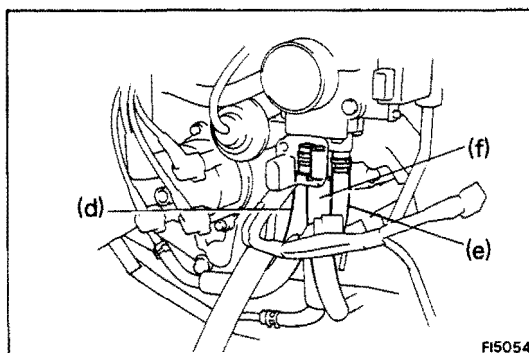

- (d) Water by-pass hose from water outlet
- (e) Water by-pass hose from water by-pass pipe
- (f) Air hose from air tube

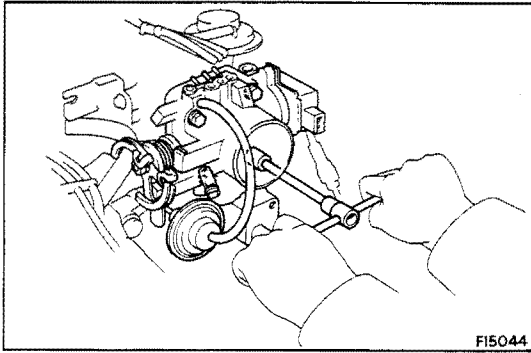

FI5044

**9. REMOVE THROTTLE BODY**

Remove the four bolts, throttle body and gasket.

**10. IF NECESSARY, REMOVE ISC VALVE FROM THROTTLE BODY**

(See step 2 on page FI-175)

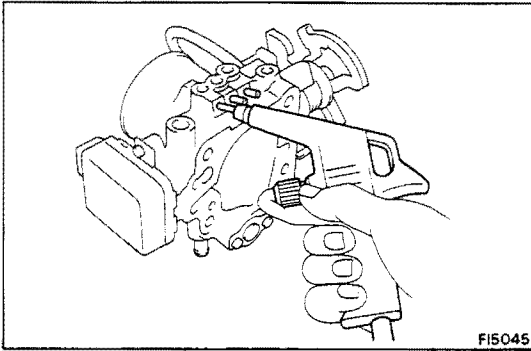

FI5045

**INSPECTION OF THROTTLE BODY**

**1. CLEAN THROTTLE BODY**

- (a) Using a soft brush and carburetor cleaner, clean the cast parts.
- (b) Using compressed air, clean all the passages and apertures.

**NOTICE:** To prevent deterioration, do not clean the throttle position sensor.

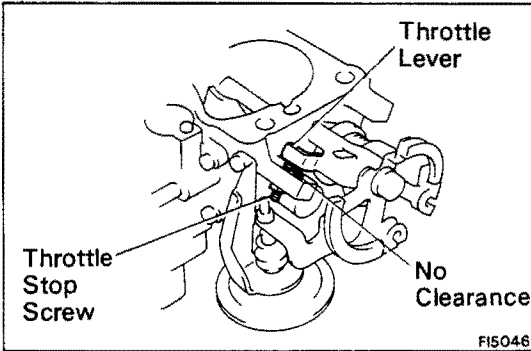

FI5046

**2. INSPECT THROTTLE VALVE**

- (a) Apply vacuum to the throttle opener.
- (b) Check that there is no clearance between the throttle stop screw and throttle lever when the throttle valve is fully closed.

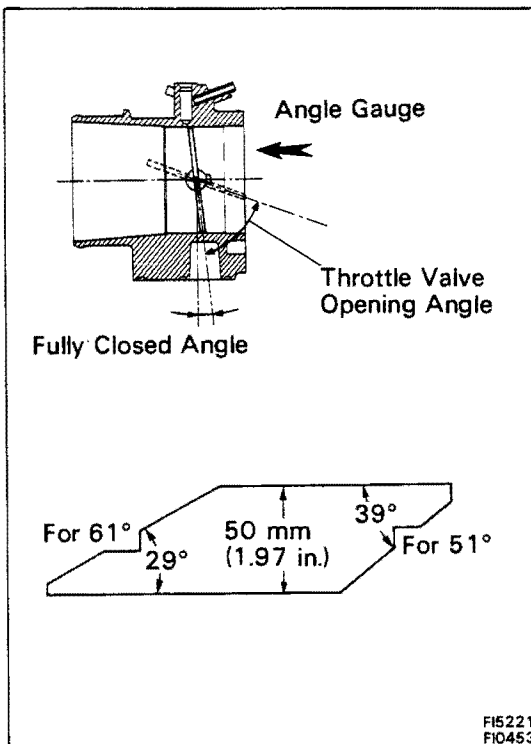

FI5221  
FI0453

**3. INSPECT THROTTLE POSITION SENSOR**

- (a) Apply vacuum to the throttle opener.
- (b) Make an angle gauge as shown in the illustration.
- (c) Set the throttle valve opening to 51° or 61° from the vertical position (incl. throttle valve fully closed angle 6°).

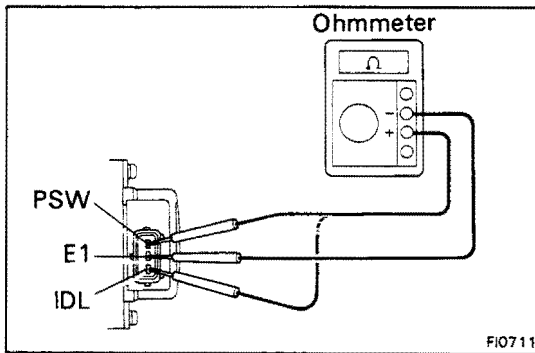

- (d) Using an ohmmeter, check the continuity between each terminal.

Throttle valve opening angle	Continuity	
	IDL – E1	PSW – E1
51° from vertical	No continuity	No continuity
61° from vertical	No continuity	Continuity
Less than 7.5° from vertical	Continuity	No continuity

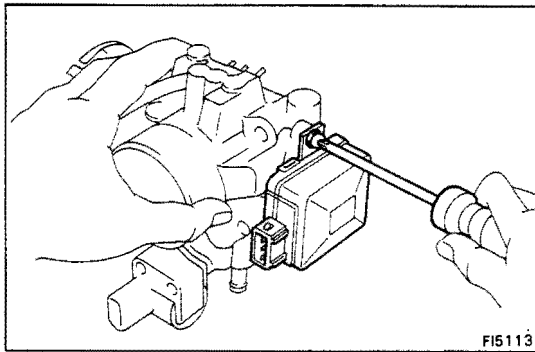

**4. IF NECESSARY, ADJUST THROTTLE POSITION SENSOR**

- (a) Loosen the two set screws of the sensor.

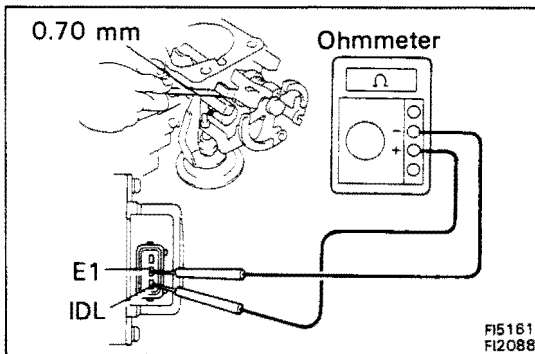

- (b) Apply vacuum to the throttle opener.  
 (c) Insert a 0.70 mm (0.028 in.) thickness gauge, between the throttle stop screw and stop lever.  
 (d) Connect the test probe of an ohmmeter to the terminals IDL and E1 of the sensor.  
 (e) Gradually turn the sensor clockwise until the ohmmeter indicator deflects, and secure it with the two set screws.

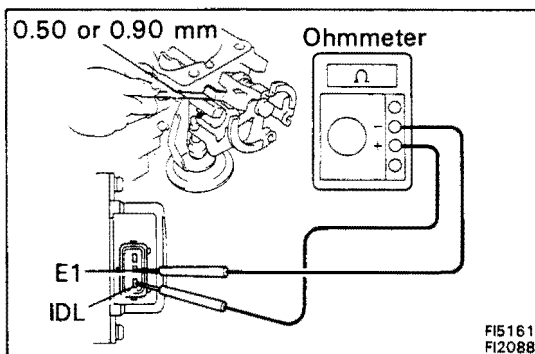

- (f) Recheck the continuity between terminals IDL and E1.

Clearance between lever and stop screw	Continuity (IDL – E1)
0.50 mm (0.002 in.)	Continuity
0.90 mm (0.035 in.)	No continuity

## INSTALLATION OF THROTTLE BODY

1. **INSTALL ISC VALVE TO THROTTLE BODY**  
(See step 1 on page FI-175)

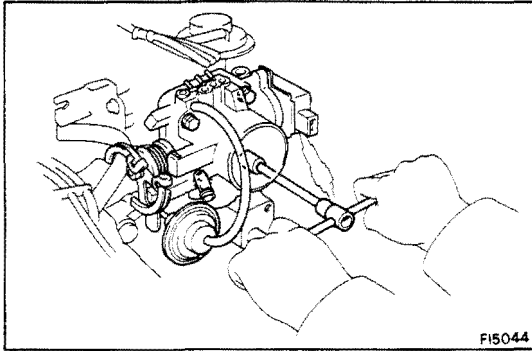

2. **INSTALL THROTTLE BODY**

Install a new gasket and the throttle body with the four bolts.

**Torque: 195 kg-cm (14 ft-lb, 19 N·m)**

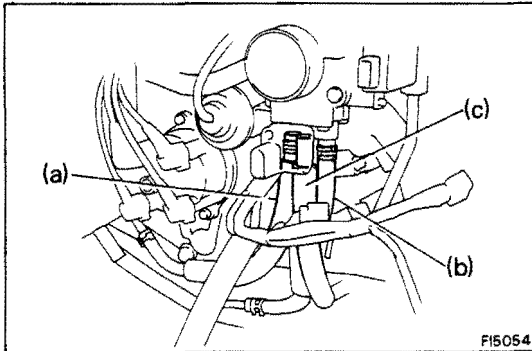

3. **CONNECT HOSES TO THROTTLE BODY**

- (a) Water by-pass hose from water outlet
- (b) Water by-pass hose from water by-pass pipe
- (c) Air hose from air tube

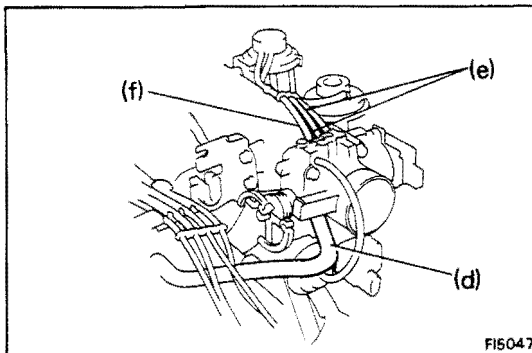

- (d) PCV hose
- (e) Two vacuum hoses from EGR vacuum modulator
- (f) Vacuum hose from EVAP BSV

4. **CONNECT ISC VALVE CONNECTOR**

5. **CONNECT THROTTLE POSITION SENSOR CONNECTOR**

6. **CONNECT AIR CLEANER HOSE**

7. **CONNECT ACCELERATOR CABLE, AND ADJUST IT**

8. (A/T)  
**CONNECT THROTTLE CABLE, AND ADJUST IT**

9. **FILL WITH ENGINE COOLANT (See page CO-6)**

10. **CONNECT CABLE TO NEGATIVE TERMINAL OF BATTERY**

## Throttle Body (5S-FE w/ ECT)

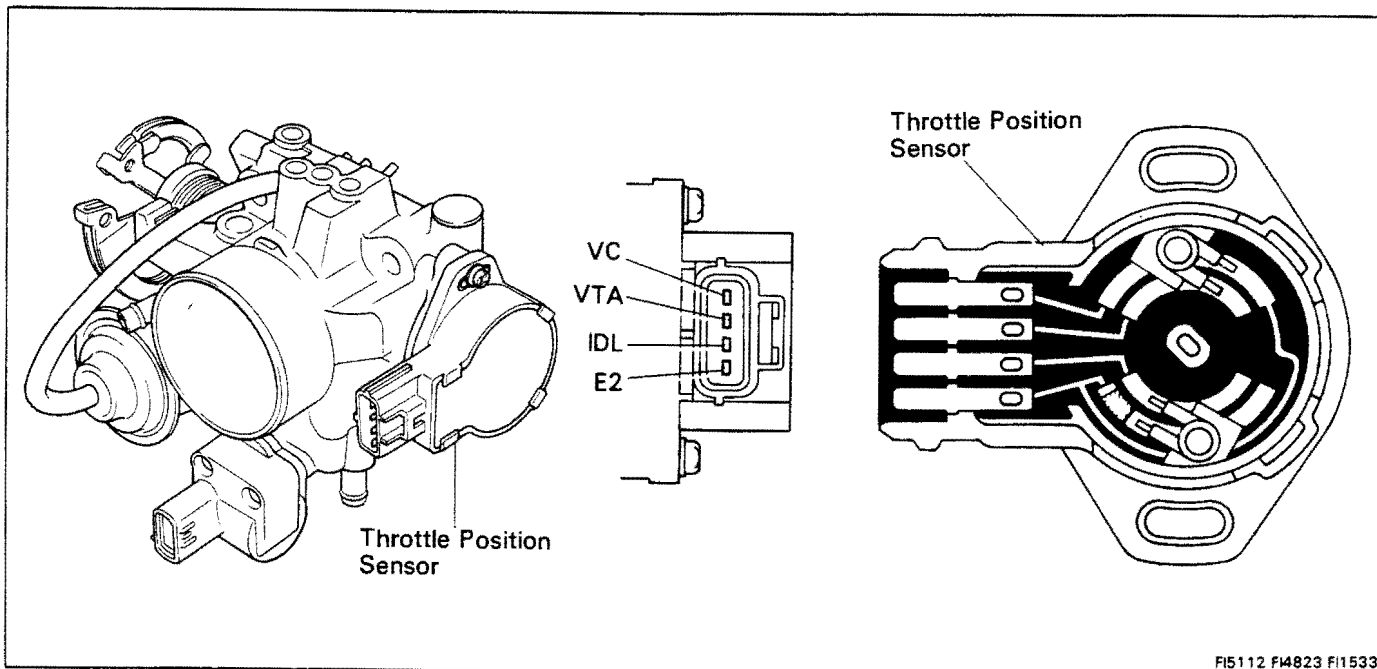

### ON-VEHICLE INSPECTION

#### 1. INSPECT THROTTLE BODY (See step 1 on page FI-157)

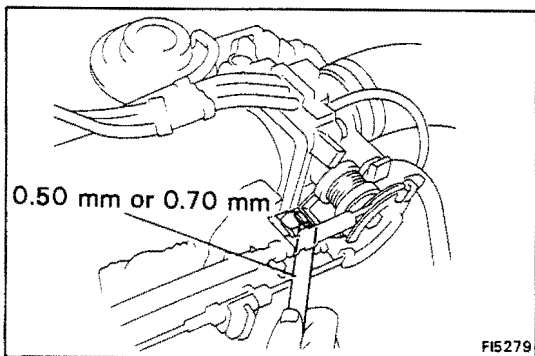

#### 2. INSPECT THROTTLE POSITION SENSOR

- (a) Apply vacuum to the throttle opener.
- (b) Disconnect the sensor connector.
- (c) Insert a thickness gauge between the throttle stop screw and stop lever.
- (d) Using an ohmmeter, measure the resistance between each terminal.

Clearance between lever and stop screw	Between terminals	Resistance
0 mm (0 in.)	VTA - E2	0.2 - 0.8 k $\Omega$
0.50 mm (0.020 in.)	IDL - E2	2.3 k $\Omega$ or less
0.70 mm (0.028 in.)	IDL - E2	Infinity
Throttle valve fully opened	VTA - E2	3.3 - 10 k $\Omega$
-	VC - E2	3 - 7 k $\Omega$

- (e) Reconnect the sensor connector.

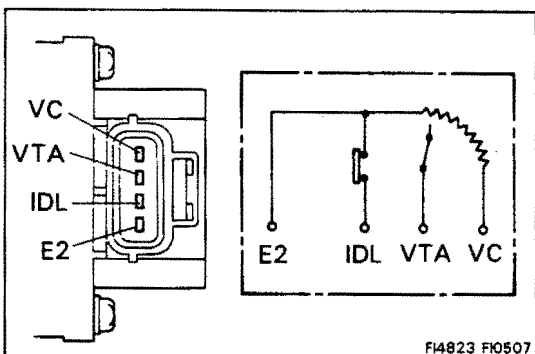

#### 3. INSPECT THROTTLE OPENER (See step 3 on page FI-157)

## REMOVAL OF THROTTLE BODY

(See page FI-159)

## INSPECTION OF THROTTLE BODY

1. **CLEAN THROTTLE BODY**  
(See step 1 on page FI-160)
2. **INSPECT THROTTLE VALVE**  
(See step 2 on page FI-160)
3. **INSPECT THROTTLE POSITION SENSOR**  
(See step 2 on page FI-163)
4. **IF NECESSARY, ADJUST THROTTLE POSITION SENSOR**

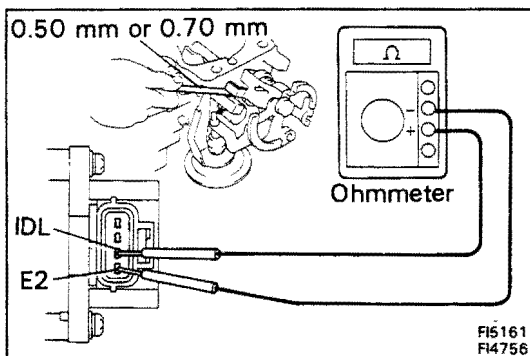
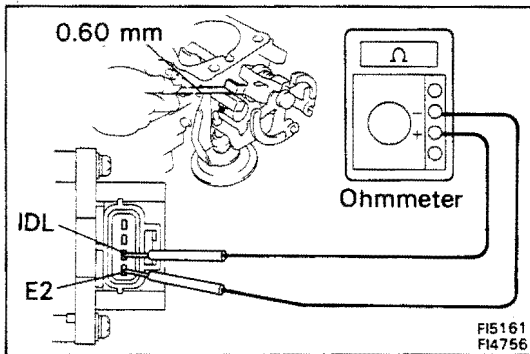
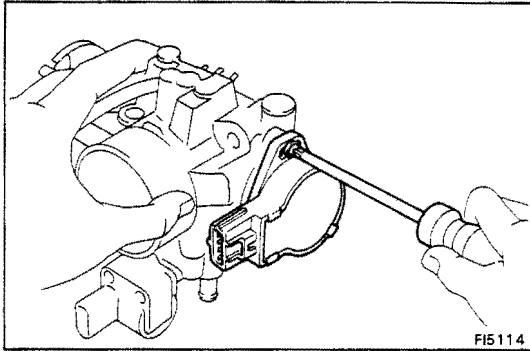

- (a) Loosen the two set screws of the sensor.
- (b) Apply vacuum to the throttle opener.
- (c) Insert a 0.60 mm (0.024 in.) thickness gauge, between the throttle stop screw and stop lever.
- (d) Connect the test probe of an ohmmeter to the terminals IDL and E2 of the sensor.
- (e) Gradually turn the sensor clockwise until the ohmmeter indicator deflects, and secure it with the two set screws.
- (f) Recheck the continuity between terminals IDL and E2.

Clearance between lever and stop screw	Continuity (IDL – E2)
0.50 mm (0.020 in.)	Continuity
0.70 mm (0.028 in.)	No continuity

## INSTALLATION OF THROTTLE BODY

(See page FI-162)

## Throttle Body (3S-GE)

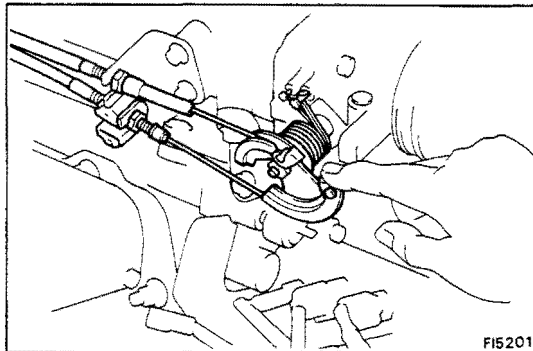
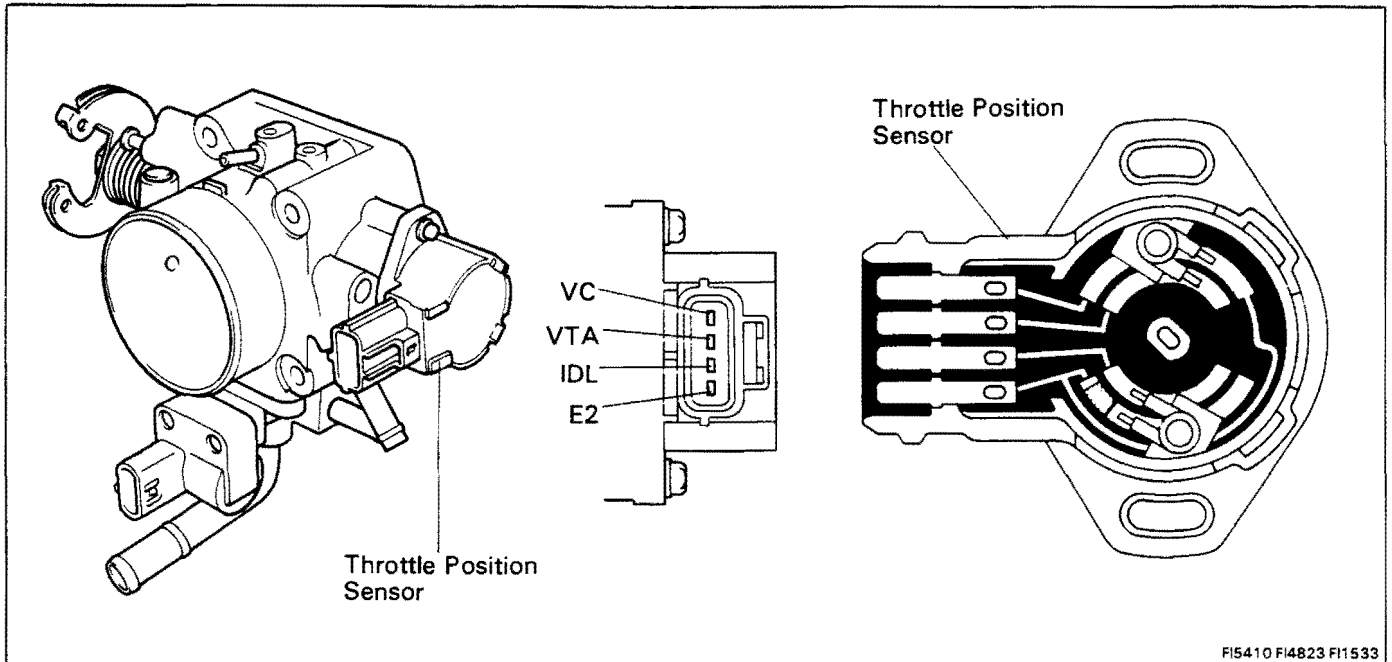

FI5201

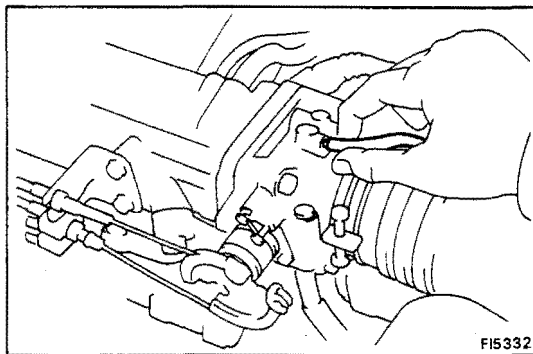

FI5332

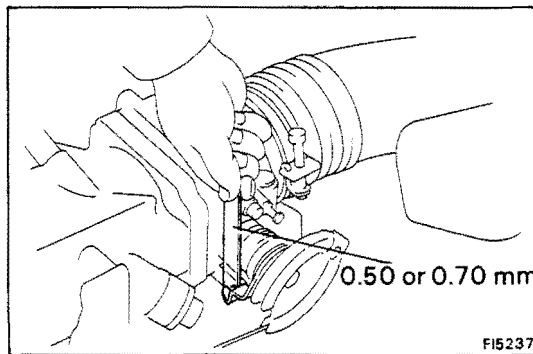

FI5237

### ON-VEHICLE INSPECTION

#### 1. INSPECT THROTTLE BODY

- (a) Check that the throttle linkage moves smoothly.

- (b) Check the vacuum at P port.
- Start the engine.
  - Check the vacuum with your finger.

**At idling** - - - - - **No vacuum**  
**Other than idling** - - - **Vacuum**

#### 2. INSPECT THROTTLE POSITION SENSOR

- (a) Disconnect the sensor connector.
- (b) Insert a thickness gauge between the throttle stop screw and stop lever.
- (c) Using an ohmmeter, measure the resistance between each terminal.



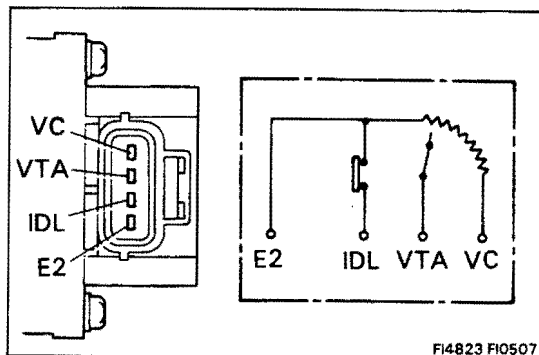

Clearance between lever and stop screw	Between terminals	Resistance
0 mm (0 in.)	VTA - E2	0.2 - 0.8 k $\Omega$
0.50 mm (0.020 in.)	IDL - E2	2.3 k $\Omega$ or less
0.70 mm (0.028 in.)	IDL - E2	Infinity
Throttle valve fully opened	VTA - E2	3.3 - 10 k $\Omega$
-	VC - E2	3 - 7 k $\Omega$

(d) Reconnect the sensor connector.

## REMOVAL OF THROTTLE BODY

1. **DISCONNECT CABLE FROM NEGATIVE TERMINAL OF BATTERY**
2. **DRAIN ENGINE COOLANT (See page CO-6)**
3. (A/T)  
**DISCONNECT THROTTLE CABLE FROM THROTTLE LINKAGE**
4. **DISCONNECT ACCELERATOR CABLE FROM THROTTLE LINKAGE**
5. **REMOVE AIR CLEANER CAP AND AIR CLEANER HOSE**
6. **DISCONNECT THROTTLE POSITION SENSOR CONNECTOR**
7. **DISCONNECT ISC VALVE CONNECTOR**
8. **DISCONNECT HOSES FROM THROTTLE BODY**
  - (a) PCV hose
  - (b) (w/ TWC)  
Vacuum hose from EVAP BVSV
  - (d) Water by-pass hose from water outlet
  - (e) Water by-pass hose from water by-pass pipe
9. **REMOVE THROTTLE BODY**  
Remove the four bolts, throttle body and gasket.
10. **IF NECESSARY, REMOVE ISC VALVE FROM THROTTLE BODY**  
(See step 2 on page FI-177)

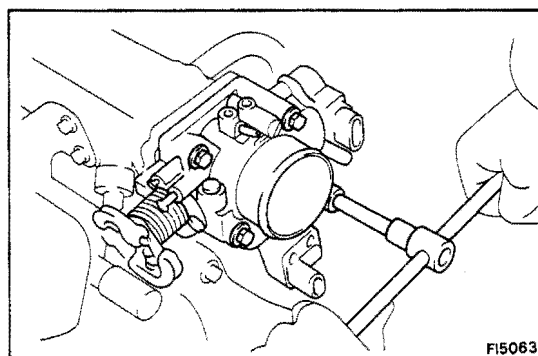
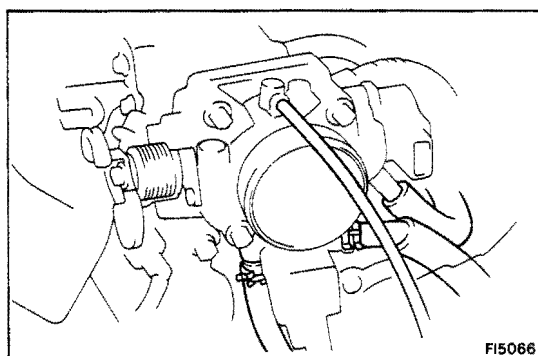

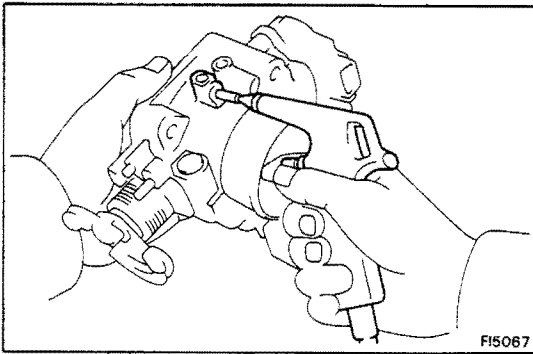

## INSPECTION OF THROTTLE BODY

### 1. CLEAN THROTTLE BODY

- (a) Using a soft brush and carburetor cleaner, clean the cast parts.
- (b) Using compressed air, clean all the passages and apertures.

**NOTICE:** To prevent deterioration, do not clean the throttle position sensor.

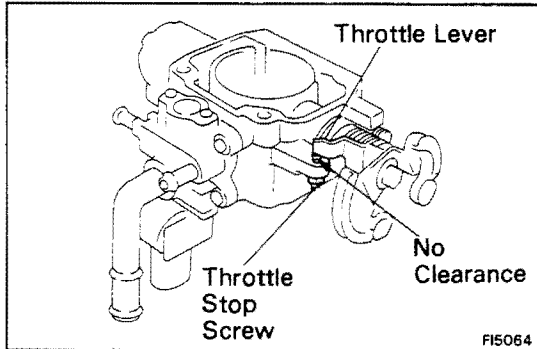

### 2. INSPECT THROTTLE VALVE

Check that there is no clearance between the throttle stop screw and throttle lever when the throttle valve is fully closed.

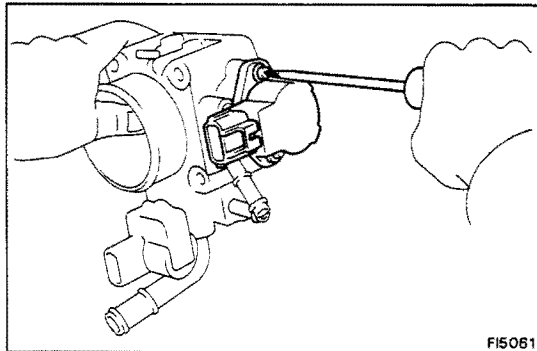

### 3. INSPECT THROTTLE POSITION SENSOR (See step 2 on page FI-165)

### 4. IF NECESSARY, ADJUST THROTTLE POSITION SENSOR

- (a) Loosen the two set screws of the sensor.
- (b) Insert a 0.60 mm (0.024 in.) thickness gauge, between the throttle stop screw and stop lever.
- (c) Connect the test probe of an ohmmeter to the terminals IDL and E2 of the sensor.
- (d) Gradually turn the sensor clockwise until the ohmmeter indicator deflects, and secure it with the two set screws.

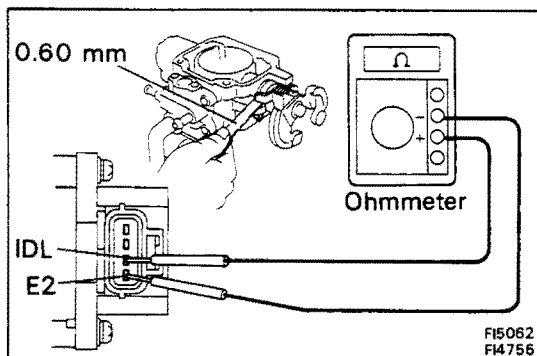

- (e) Recheck the continuity between terminals IDL and E2.

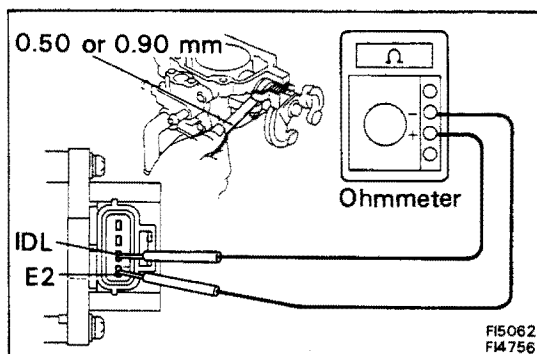

Clearance between lever and stop screw	Continuity (IDL – E2)
0.50 mm (0.020 in.)	Continuity
0.70 mm (0.028 in.)	No continuity

## INSTALLATION OF THROTTLE BODY

1. **INSTALL ISC VALVE TO THROTTLE BODY**  
(See step 1 on page FI-177)

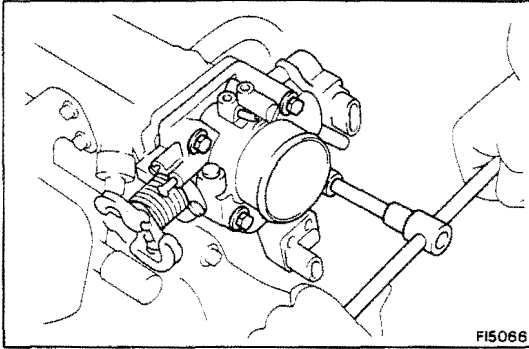

2. **INSTALL THROTTLE BODY**

Install a new gasket and the throttle body with the four bolts.

**Torque: 195 kg-cm (14 ft-lb, 19 N·m)**

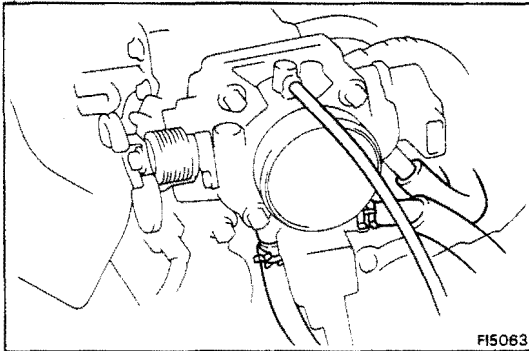

3. **CONNECT HOSES TO THROTTLE BODY**

- (a) PCV hose
- (b) (w/ TWC)  
Vacuum hose from EVAP BVS
- (c) Water by-pass hose from water outlet
- (d) Water by-pass hose from water by-pass pipe

4. **CONNECT ISC VALVE CONNECTOR**

5. **CONNECT THROTTLE POSITION SENSOR CONNECTOR**

6. **CONNECT AIR CLEANER HOSE**

7. **CONNECT ACCELERATOR CABLE, AND ADJUST IT**

8. (A/T)  
**CONNECT THROTTLE CABLE, AND ADJUST IT**

9. **FILL WITH ENGINE COOLANT (See page CO-6)**

10. **CONNECT CABLE TO NEGATIVE TERMINAL OF BATTERY**

# Throttle Body (3S-GTE)

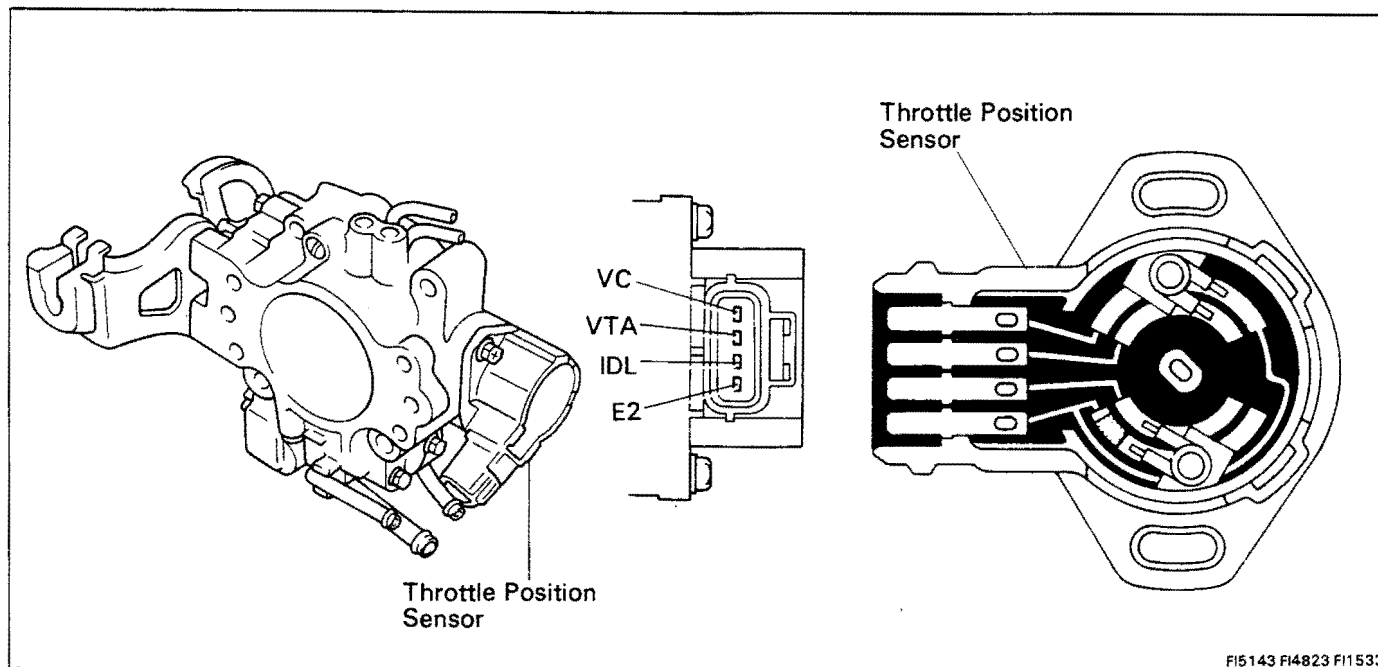

FI5143 FI4823 FI1533

## ON-VEHICLE INSPECTION

### 1. INSPECT THROTTLE BODY

(a) Check that the throttle linkage moves smoothly.

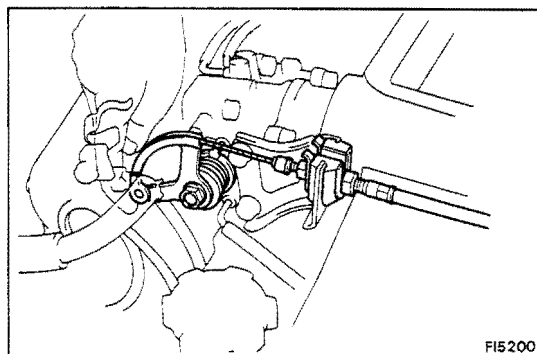

(b) Check the vacuum at each port.

- Start the engine.
- Check the vacuum with your finger.

Port name	At idling	Other than idling
P	No vacuum	Vacuum
E	No Vacuum	Vacuum

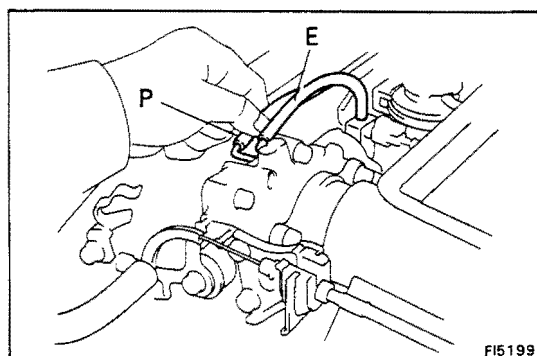

### 2. INSPECT THROTTLE POSITION SENSOR

- (a) Disconnect the sensor connector.
- (b) Insert a thickness gauge between the throttle stop screw and stop lever.
- (c) Using an ohmmeter, measure the resistance between each terminal.

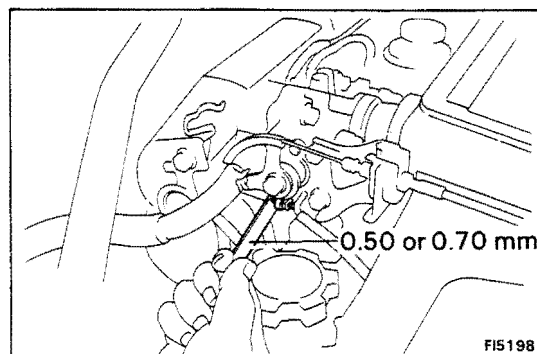

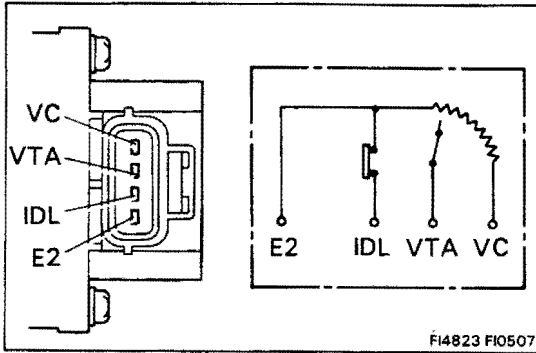

Clearance between lever and stop screw	Between terminals	Resistance
0 mm (0 in.)	VTA - E2	0.2 - 0.8 kΩ
0.50 mm (0.020 in.)	IDL - E2	2.3 kΩ or less
0.70 mm (0.028 in.)	IDL - E2	Infinity
Throttle valve fully opened	VTA - E2	3.3 - 10 kΩ
-	VC - E2	3 - 7 kΩ

(d) Reconnect the sensor connector.

### REMOVAL OF THROTTLE BODY

1. **DISCONNECT CABLE FROM NEGATIVE TERMINAL OF BATTERY**
2. **DRAIN ENGINE COOLANT** (See page CO-6)
3. **DISCONNECT ACCELERATOR CABLE FROM THROTTLE LINKAGE**
4. **REMOVE INTERCOOLER**  
(See steps 4 to 6 on page TC-9)
5. **REMOVE AIR CONNECTOR**  
Remove the four bolts and air connector.

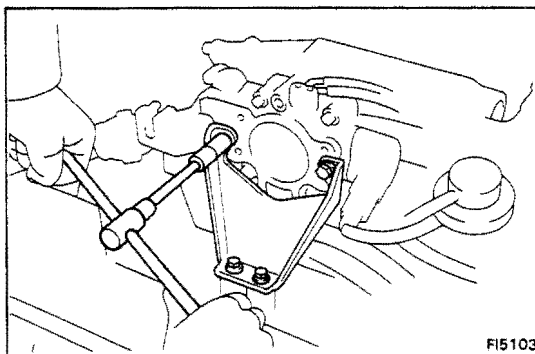
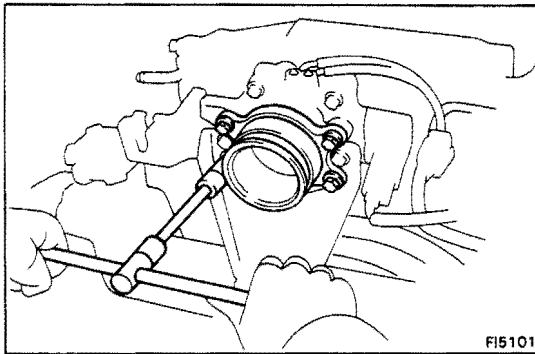

6. **REMOVE AIR CONNECTOR STAY**  
Remove the four bolts, air connector stay.
7. **DISCONNECT THROTTLE POSITION SENSOR CONNECTOR**
8. **DISCONNECT ISC VALVE CONNECTOR**

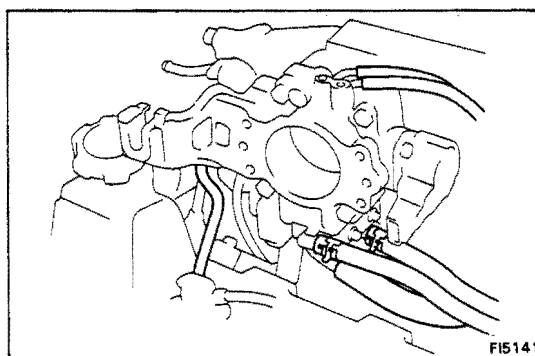

9. **DISCONNECT HOSES FROM THROTTLE BODY**
  - (a) PCV hose
  - (b) Water by-pass hoses from by-pass pipe
  - (c) Two vacuum hoses for EGR
  - (d) Air hose from by-pass pipe

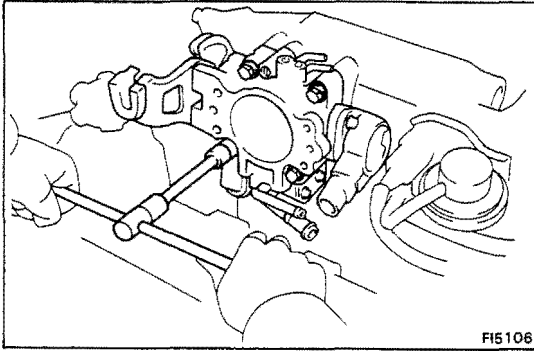

**10. REMOVE THROTTLE BODY**

Remove the four bolts, throttle body and gasket.

**11. IF NECESSARY, REMOVE ISC VALVE FROM THROTTLE BODY**

(See step 2 on page FI-179)

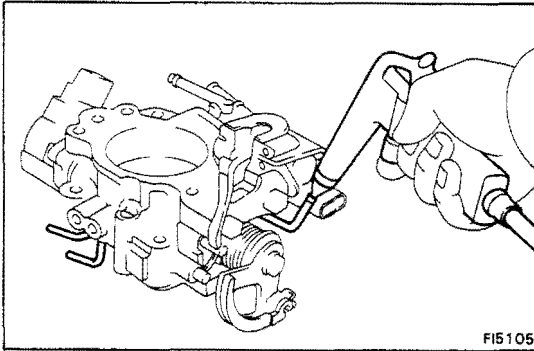

**INSPECTION OF THROTTLE BODY**

**1. CLEAN THROTTLE BODY**

- (a) Using a soft brush and carburetor cleaner, clean the cast parts.
- (b) Using compressed air, clean all the passages and apertures.

**NOTICE:** To prevent deterioration, do not clean the throttle position sensor.

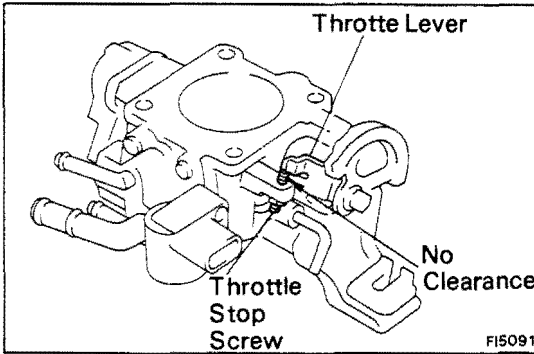

**2. INSPECT THROTTLE VALVE**

Check that there is no clearance between the throttle stop screw and throttle lever when the throttle valve is fully closed.

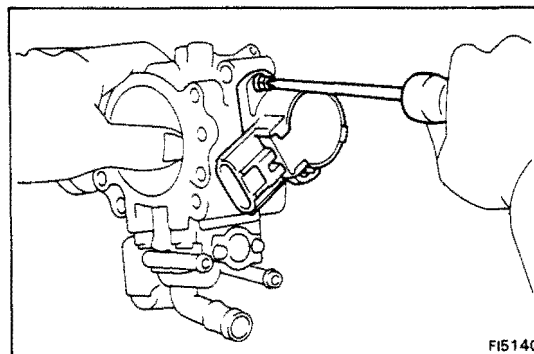

**3. INSPECT THROTTLE POSITION SENSOR**

(See page 2 on page FI-169)

**4. IF NECESSARY, ADJUST THROTTLE POSITION SENSOR**

- (a) Loosen the two mount screws of the sensor.
- (b) Insert a thickness gauge 0.60 mm (0.024 in.) between the throttle stop screw and throttle lever.
- (c) Connect the test probe of an ohmmeter to the terminals IDL and E2 of the sensor.
- (d) Gradually turn the sensor clockwise until the ohmmeter indicator deflects, and secure it with the screws.

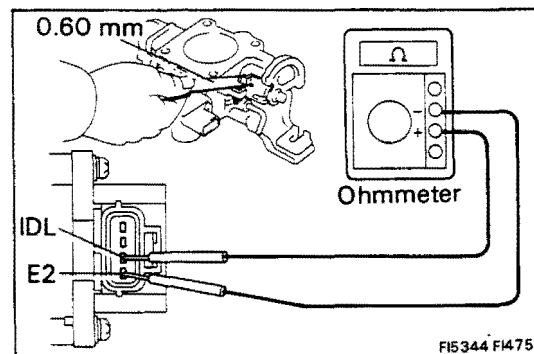

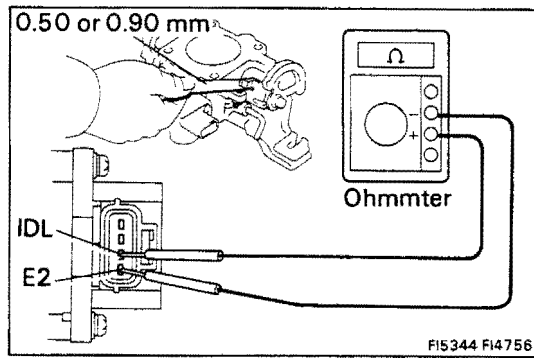

(e) Recheck the continuity between terminals IDL and E2.

Clearance between lever and stop screw	Continuity (IDL – E1)
0.50 mm (0.020 in.)	Continuity
0.90 mm (0.035 in.)	No continuity

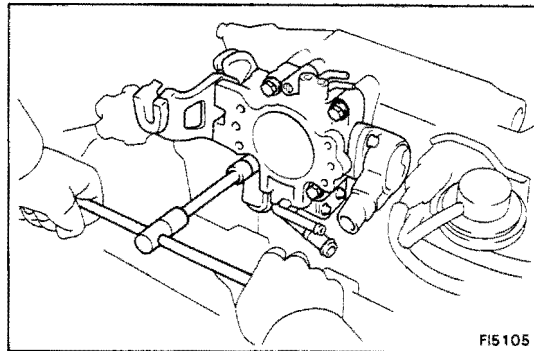

## INSTALLATION OF THROTTLE BODY

1. **INSTALL ISC VALVE TO THROTTLE BODY**  
(See step 1 on page FI-179)

2. **INSTALL THROTTLE BODY**

Install a new gasket and the throttle body with the four bolts.

**Torque: 195 kg-cm (14 ft-lb, 19 N·m)**

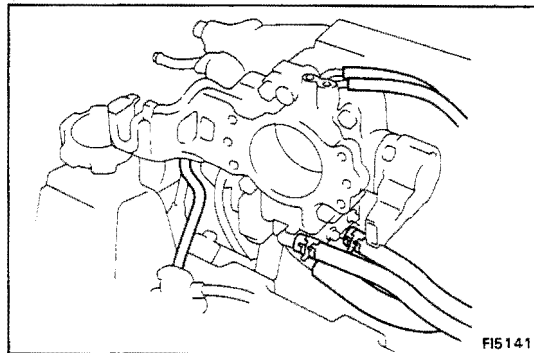

3. **CONNECT HOSES TO THROTTLE BODY**

- (a) PCV hose
- (b) Water by-pass hoses from by-pass pipe
- (c) Two vacuum hoses for EGR
- (d) Air hose from by-pass pipe

4. **CONNECT ISC VALVE CONNECTOR**

5. **CONNECT THROTTLE POSITION SENSOR CONNECTOR**

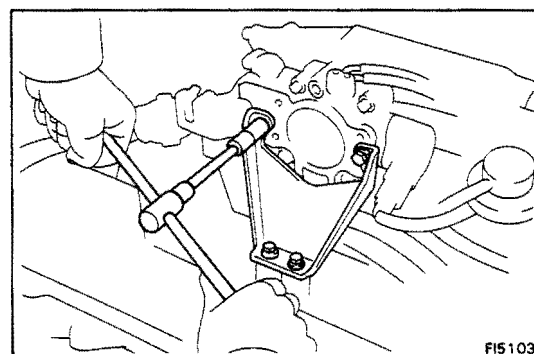

6. **INSTALL AIR CONNECTOR STAY**

Install the air connector stay with the four bolts.

**Torque:**

- 10 mm bolt head 80 kg-cm (69 in.-lb, 7.8 N·m)
- 12 mm bolt head 195 kg-cm (14 ft-lb, 19 N·m)

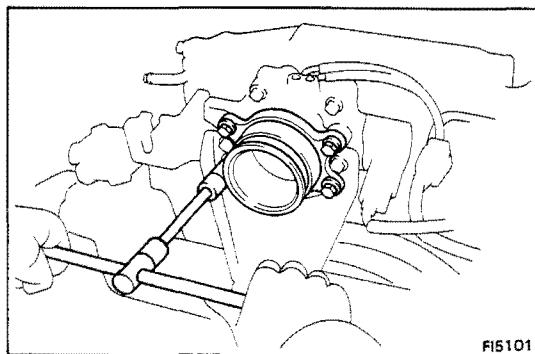
**7. INSTALL AIR CONNECTOR**

Install the air connector with the four bolts.

**Torque: 195 kg-cm (14 ft-lb, 19 N·m)**

**8. INSTALL INTERCOOLER**

(See step 11 to 13 on page TC-16)

**9. CONNECT ACCELERATOR CABLE, AND ADJUST IT****10. CONNECT CABLE TO NEGATIVE TERMINAL OF BATTERY****11. FILL ENGINE WITH COOLANT (See page CO-6)****12. CHECK FOR FUEL LEAKAGE (See page FI-11)**



## Idle Speed Control (ISC) Valve (5S-FE)

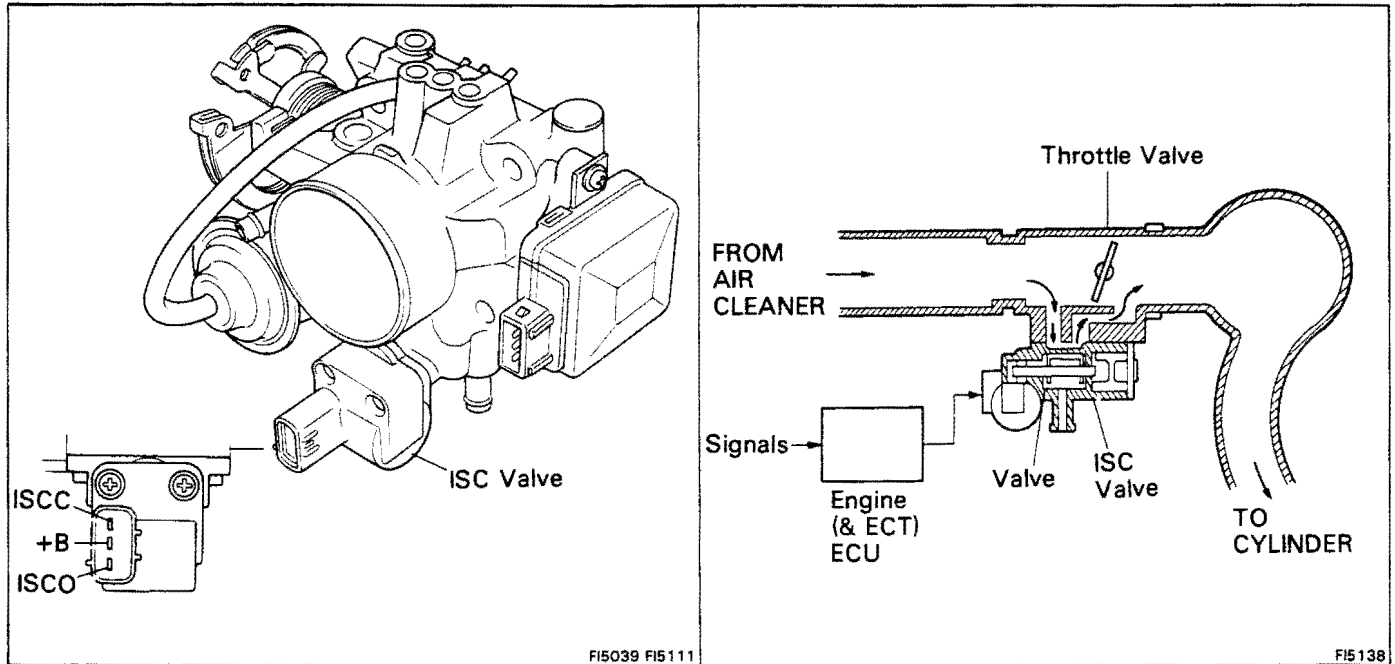

### ON-VEHICLE INSPECTION

#### 1. INSPECT ISC VALVE OPERATION

##### (a) Initial conditions:

- Engine at normal operating temperature
- Idle speed set correctly
- Transmission in N range

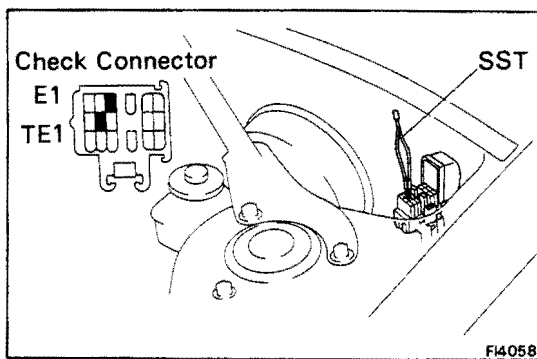

##### (b) Using SST, connect terminals TE1 and E1 of the check connector.

SST 09843-18020

##### (c) After engine rpm are kept at 1,000 – 1,300 rpm for 5 seconds, check that the rpm drop to about to idle speed.

If the rpm operation is not as specified, check the ISC valve, wiring and engine (and ECT) ECU.

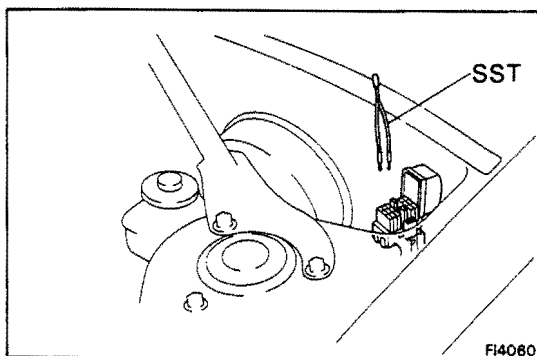

##### (d) Remove SST.

SST 09843-18020

##### (e) Check the idle speed.

**Idle speed: 700 ± 50 rpm**

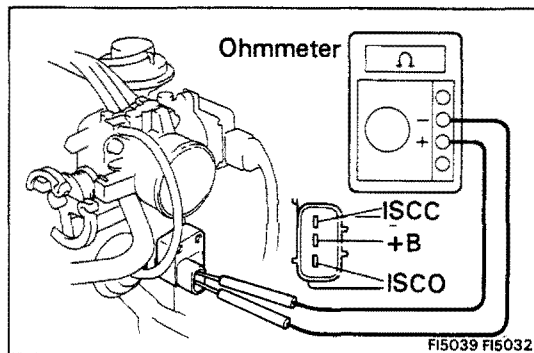

## 2. INSPECT ISC VALVE RESISTANCE

- (a) Disconnect the ISC valve connector.
- (b) Using an ohmmeter, measure the resistance between terminal +B and other terminals (ISCC, ISCO).

**Resistance: 19.3 – 22.3  $\Omega$**

If resistance is not as specified, replace the ISC valve.

- (c) Reconnect the ISC valve connector.

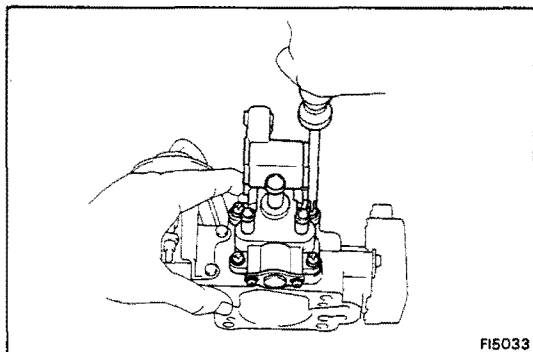

## REMOVAL OF ISC VALVE

1. REMOVE THROTTLE BODY  
(See steps 1 to 9 on page FI-159)

## 2. REMOVE ISC VALVE

Remove the four screws, ISC valve and gasket.

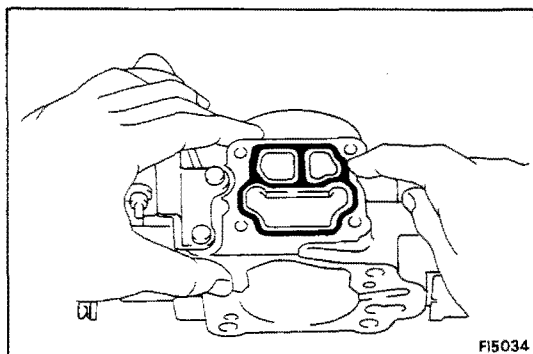

## INSTALLATION OF ISC VALVE

### 1. INSTALL ISC VALVE

- (a) Place a new gasket on the throttle body.

- (b) Install the ISC valve with the four screws.

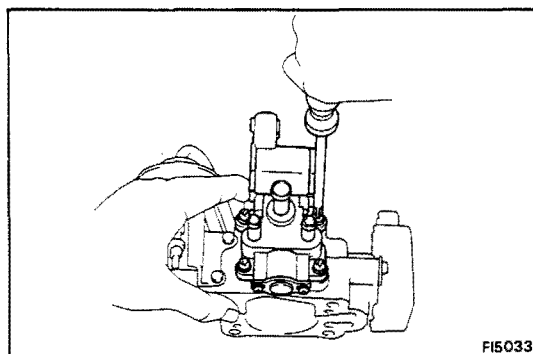

### 2. INSTALL THROTTLE BODY

(See steps 2 to 10 on page FI-162)

# Idle Speed Control (ISC) Valve (3S-GE)

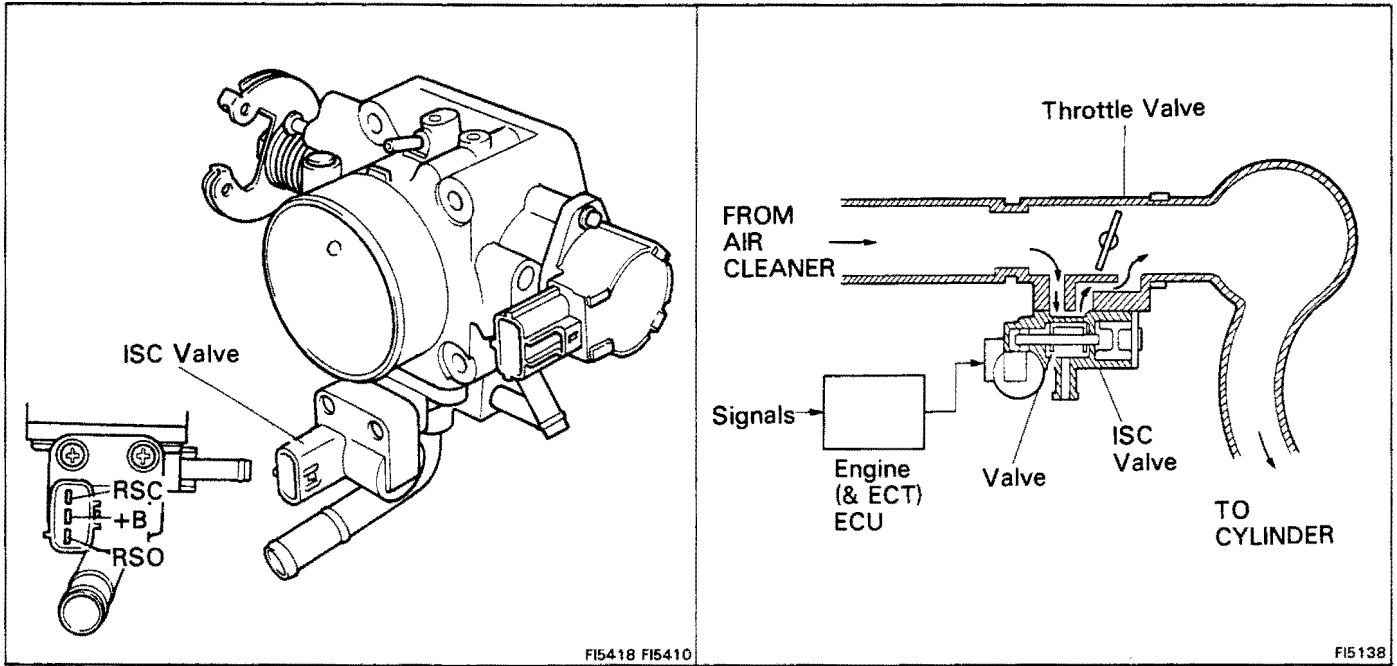

FI5418 FI5410

FI5138

## ON-VEHICLE INSPECTION

### 1. INSPECT ISC VALVE OPERATION

(a) Initial conditions:

- Engine at normal operating temperature
- Idle speed set correctly
- Transmission in N range

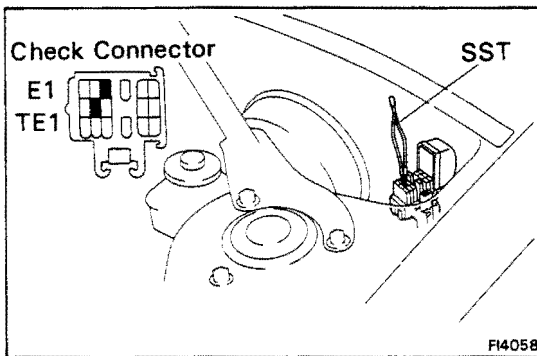

FI4058

(b) Using SST, connect terminals TE1 and E1 of the check connector.

SST 09843-18020

(c) After engine rpm are kept at 1,000 – 1,300 rpm for 5 seconds, check that the rpm drop to about idle speed.

If the rpm operation is not as specified, check the ISC valve, wiring and engine (and ECT) ECU.

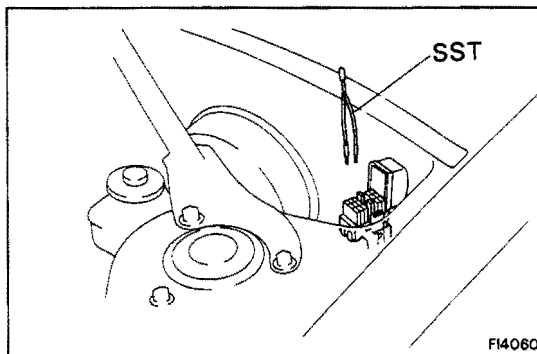

FI4060

(d) Remove SST.

SST 09843-18020

(e) Check the idle speed.

**Idle speed: 800 ± 50 rpm**

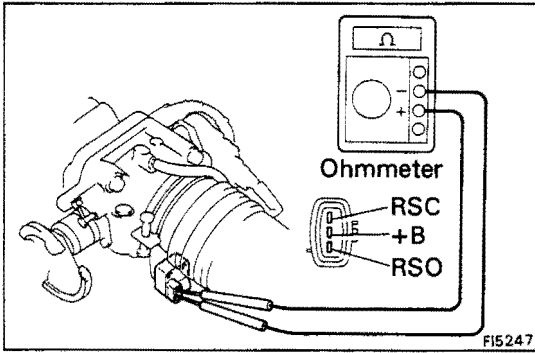

**2. INSPECT ISC VALVE RESISTANCE**

- (a) Disconnect the ISC valve connector.
- (b) Using an ohmmeter, measure the resistance between terminal +B and other terminals (RSC, RSO).

**Resistance: 19.3 – 22.3 Ω**

If resistance is not as specified, replace the ISC valve.

- (c) Reconnect the ISC valve connector.

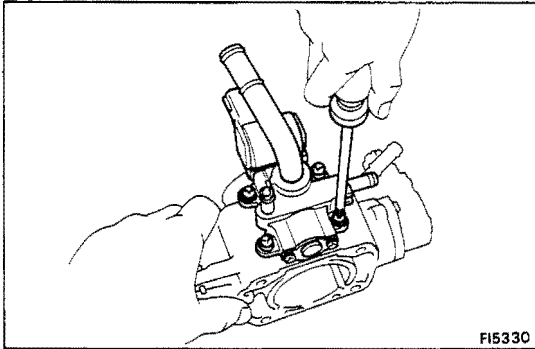

**REMOVAL OF ISC VALVE**

- 1. REMOVE THROTTLE BODY**  
 (See steps 1 to 9 on page FI-166)

**2. REMOVE ISC VALVE**

Remove the four screws, ISC valve and gasket.

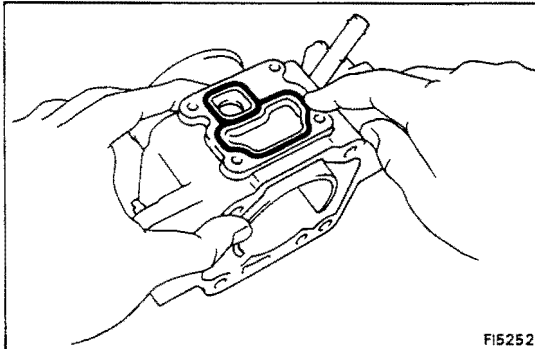

**INSTALLATION OF ISC VALVE**

**1. INSTALL ISC VALVE**

- (a) Place a new gasket on the throttle body.

- (b) Install the ISC valve with the four screws.

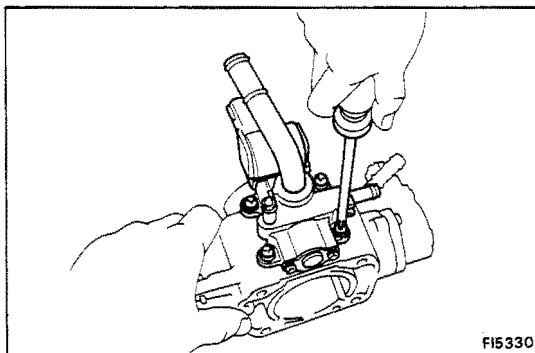

**2. INSTALL THROTTLE BODY**

(See steps 2 to 10 on page FI-168)

## Idle Speed Control (ISC) Valve (3S-GTE)

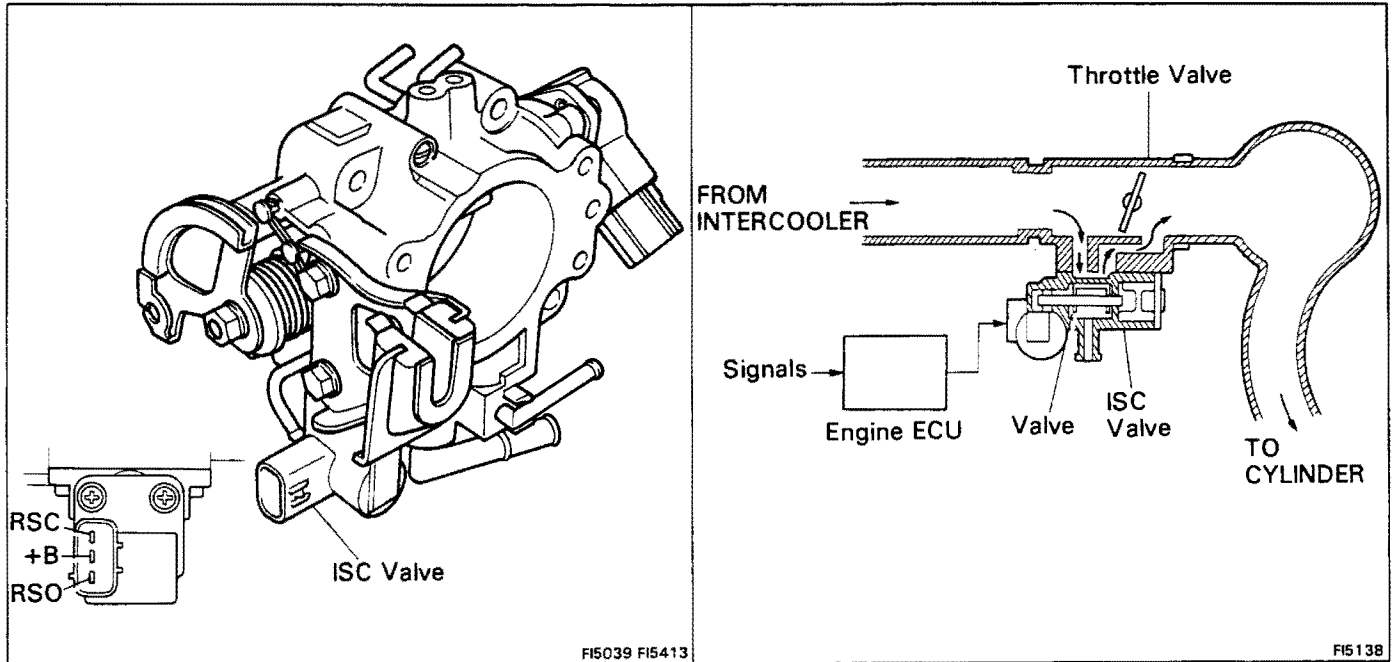

### ON-VEHICLE INSPECTION

#### 1. INSPECT ISC VALVE OPERATION

##### (a) Initial conditions:

- Engine at normal operating temperature
- Idle speed set correctly

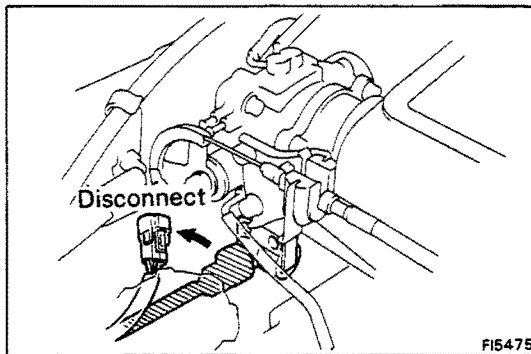

##### (b) Disconnect the ISC valve connector.

##### (c) Check the engine rpm.

**Engine rpm: 1,000 rpm or more**

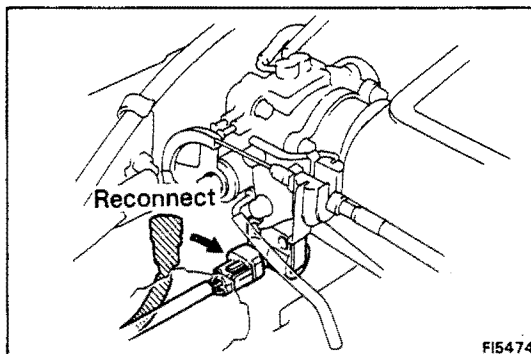

##### (d) Reconnect the ISC valve connector.

##### (e) Check that they return to the idle speed.

**Idle speed: 800 ± 50 rpm**

If the rpm operation is not as specified, check the ISC valve, wiring and ECU.

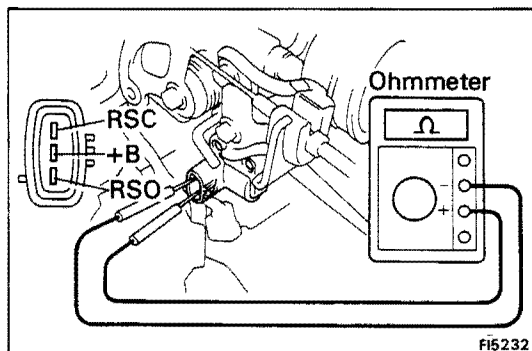

## 2. INSPECT ISC VALVE RESISTANCE

- (a) Disconnect the ISC valve connector.
- (b) Using an ohmmeter, measure the resistance between terminal +B and other terminals (RSC, RSO).

**Resistance: 19.3 – 22.3  $\Omega$**

If resistance is not as specified, replace the ISC valve.

- (c) Reconnect the ISC valve connector.

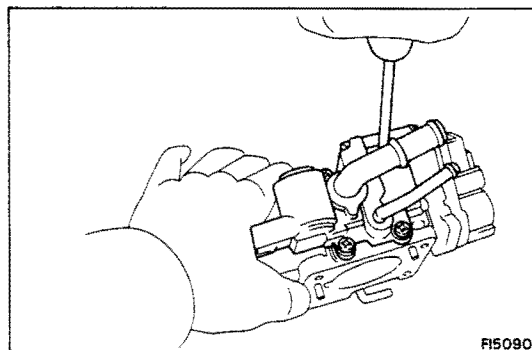

## REMOVAL OF ISC VALVE

1. REMOVE THROTTLE BODY  
(See steps 1 to 10 on pages FI-170, 171)

### 2. REMOVE ISC VALVE

Remove the four screws, ISC valve and gasket.

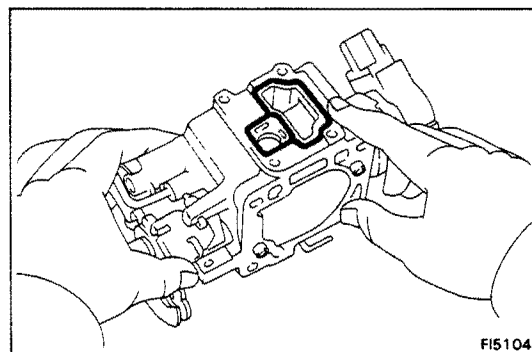

## INSTALLATION OF ISC VALVE

### 1. INSTALL ISC VALVE

- (a) Place a new gasket on the throttle body.

- (b) Install the ISC valve with the four screws.

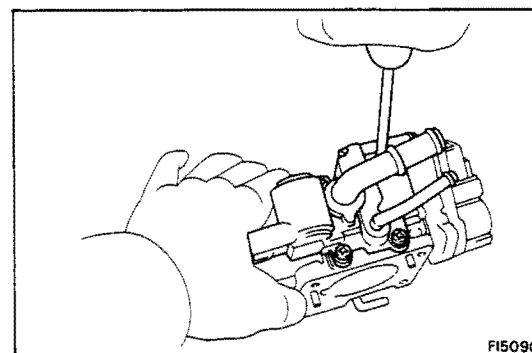

### 2. INSTALL THROTTLE BODY

(See steps 2 to 12 on pages FI-171, 173)

# ELECTRONIC CONTROL SYSTEM

## Location of Electronic Control Parts

### ECU and Circuit Opening Relay

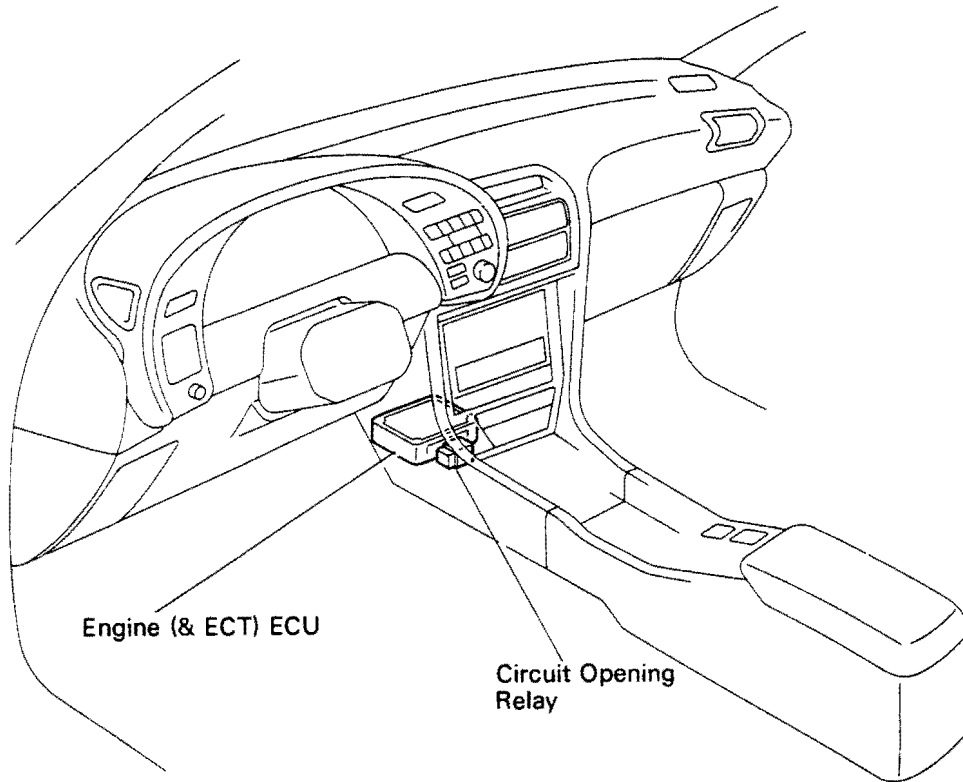

F15450

### Other Control Parts (5S-FE)

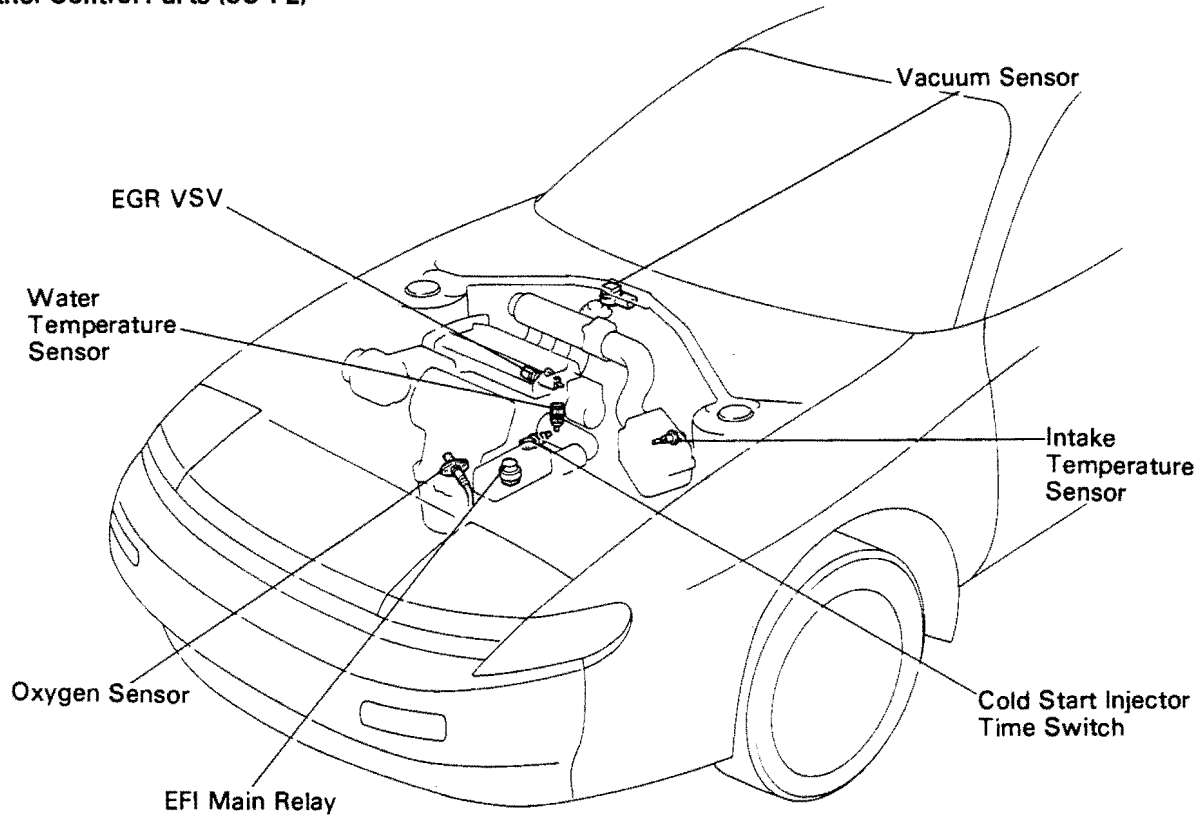

F15341

# Location of Electronic Control Parts (Cont'd)

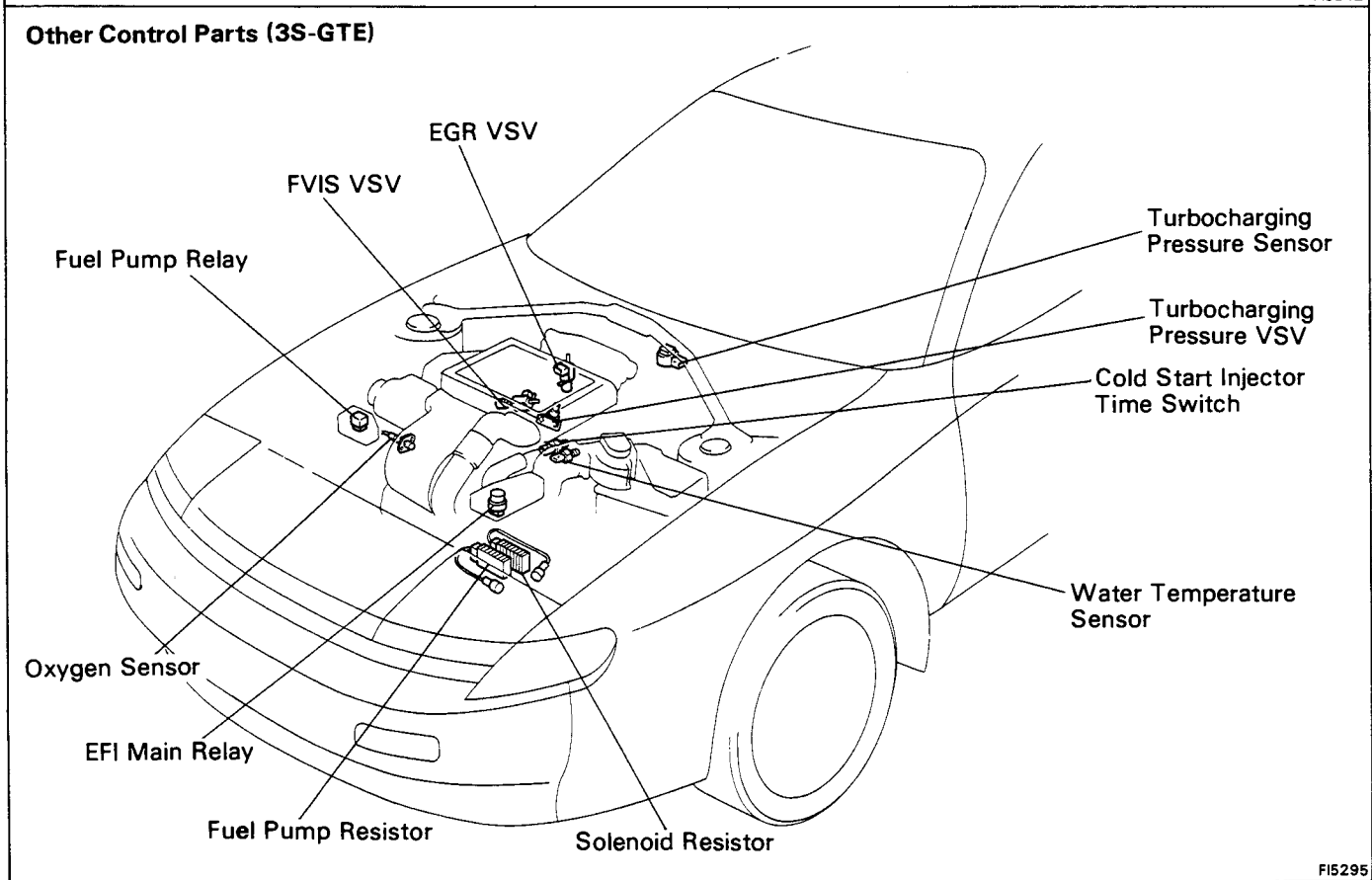
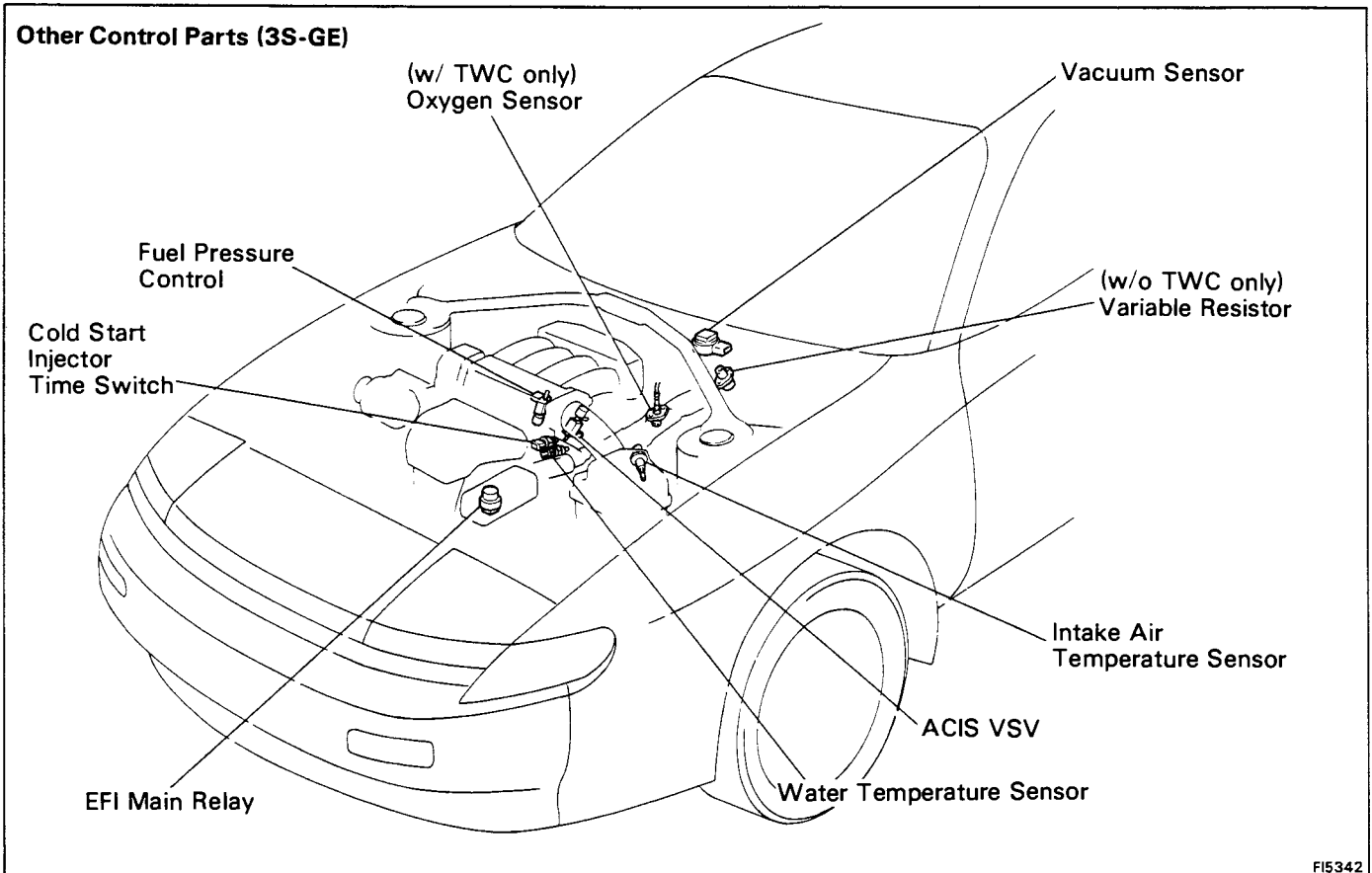



# Location of Electronic Control Parts (Cont'd)

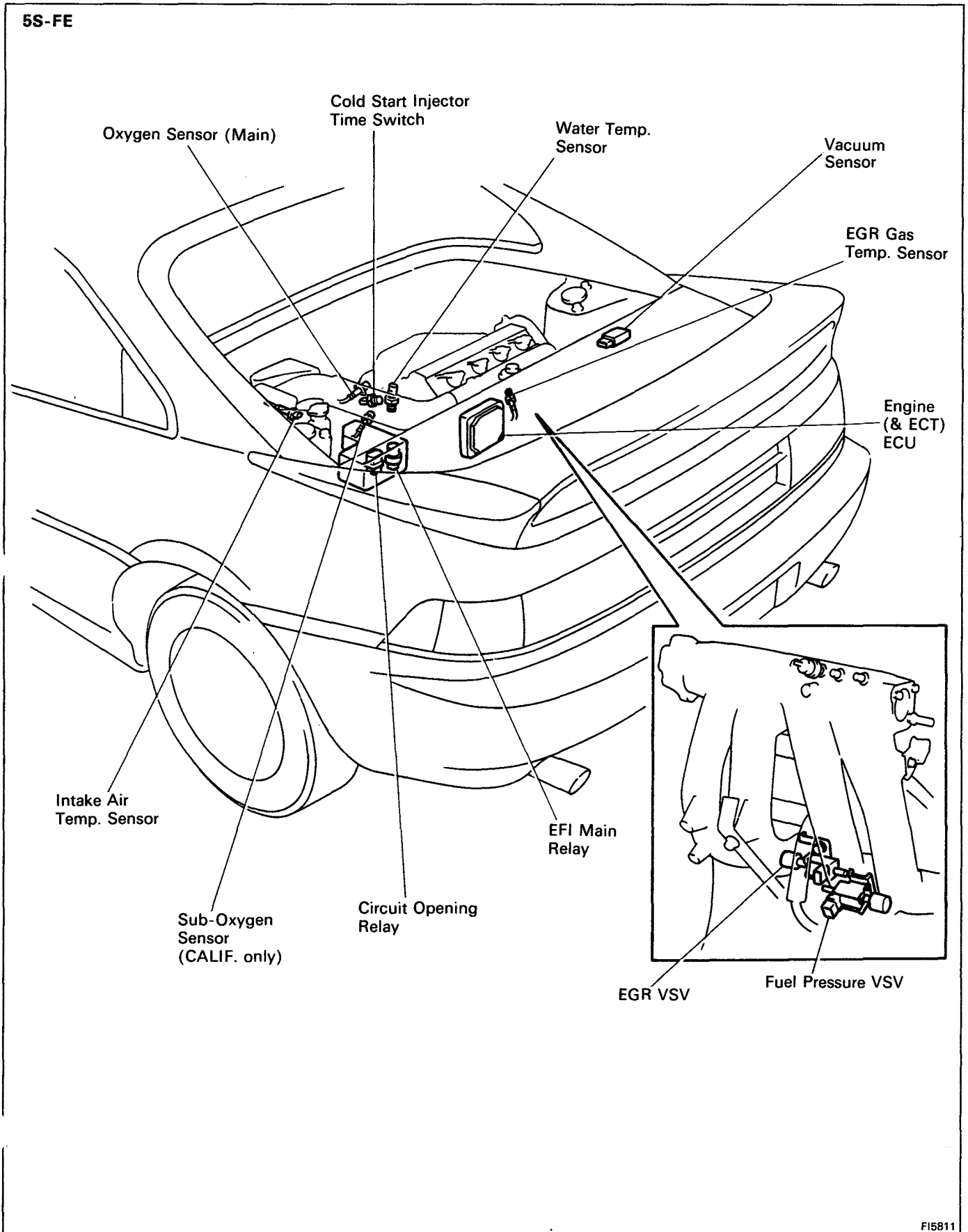

# ELECTRONIC CONTROL SYSTEM

## Location of Electronic Control Parts

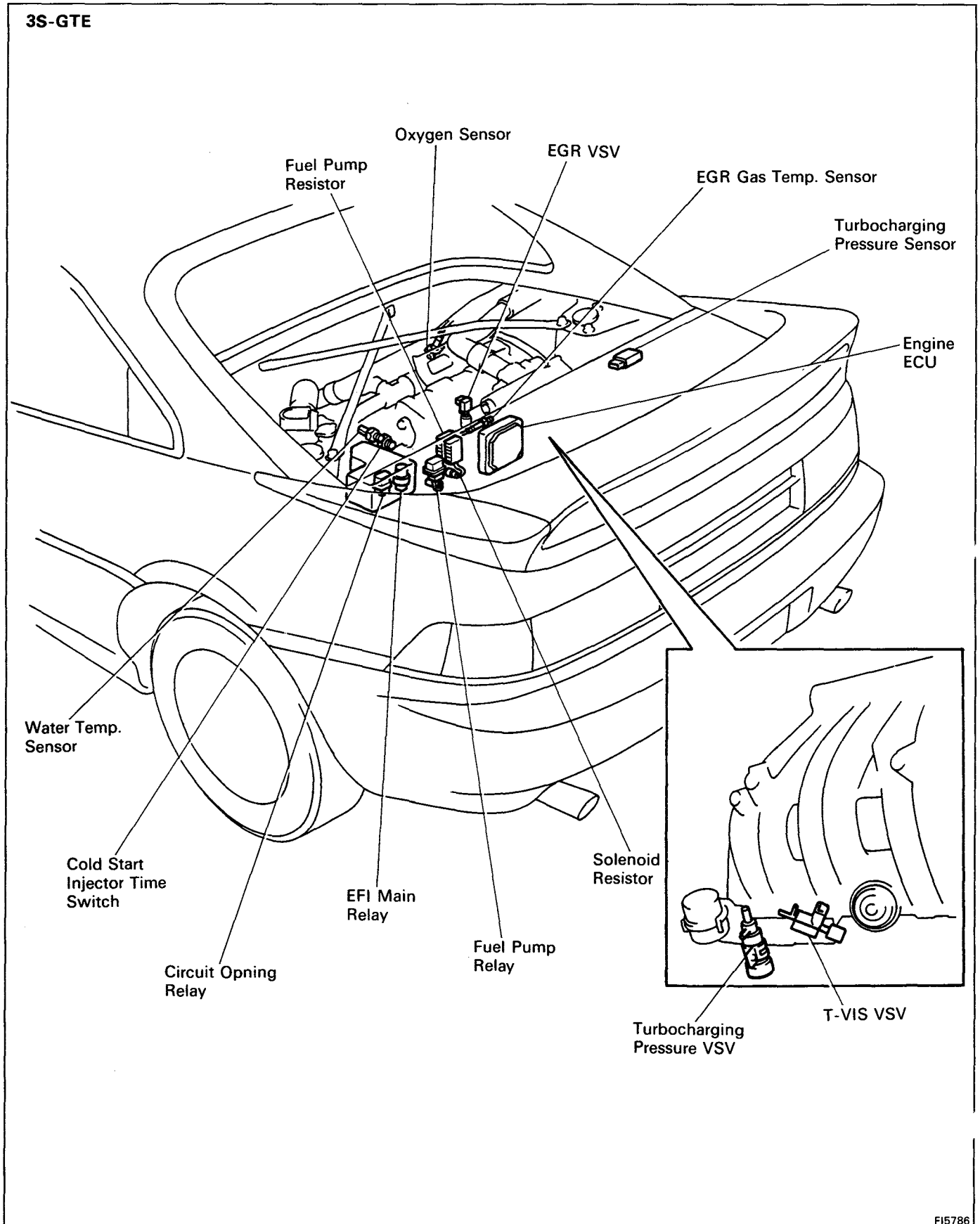

# EFI Main Relay

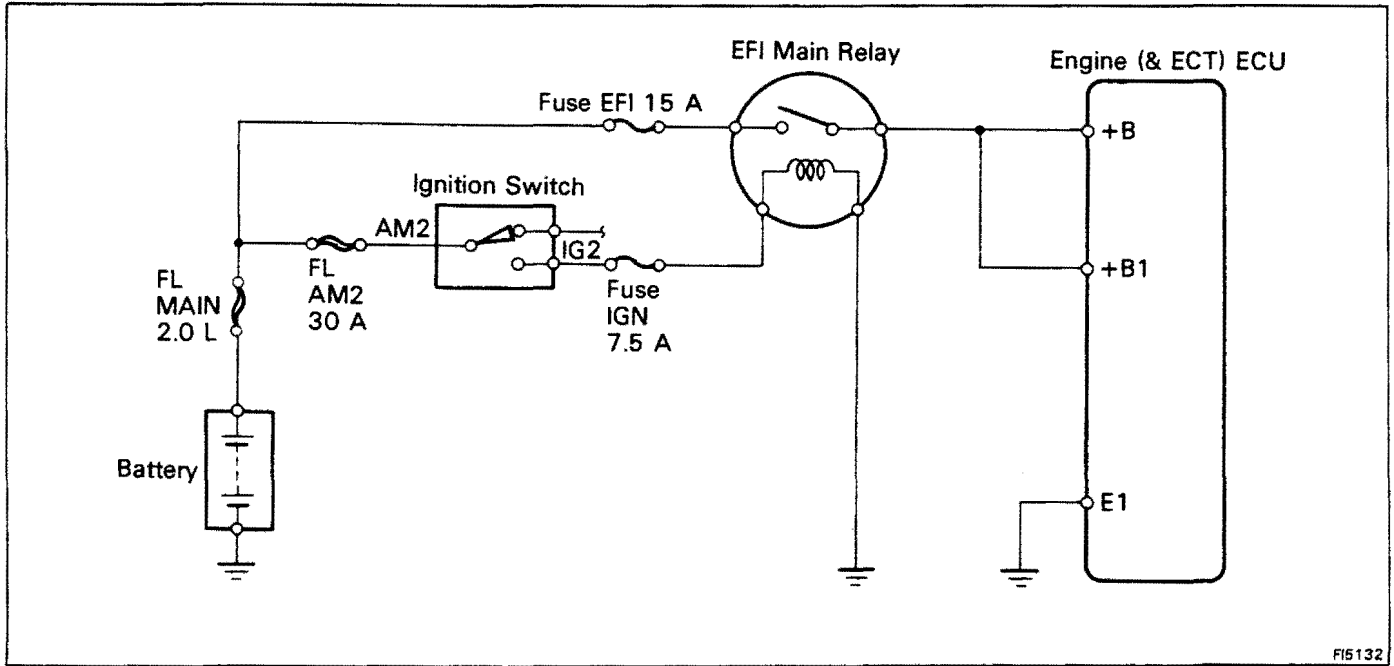

FI5132

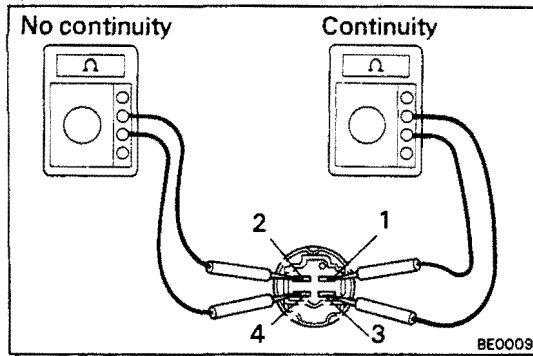

BE0003

## INSPECTION OF EFI MAIN RELAY

### 1. INSPECT RELAY CONTINUITY

- (a) Using an ohmmeter, check that there is continuity between terminals 1 and 3.
- (b) Check that there is no continuity between terminals 2 and 4.

If continuity is not as specified, replace the relay.

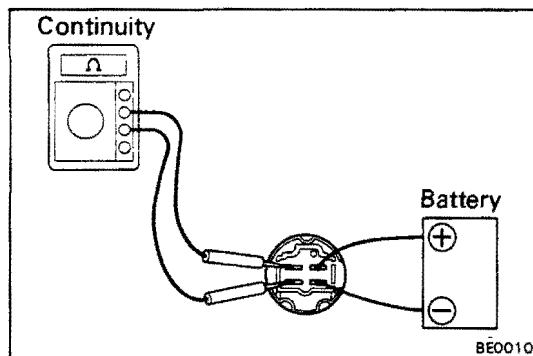

BE0010

### 2. INSPECT RELAY OPERATION

- (a) Apply battery voltage across terminals 1 and 3.
- (b) Using an ohmmeter, check that there is continuity between terminals 2 and 4.

If operation is not as specified, replace the relay.

# Circuit Opening Relay

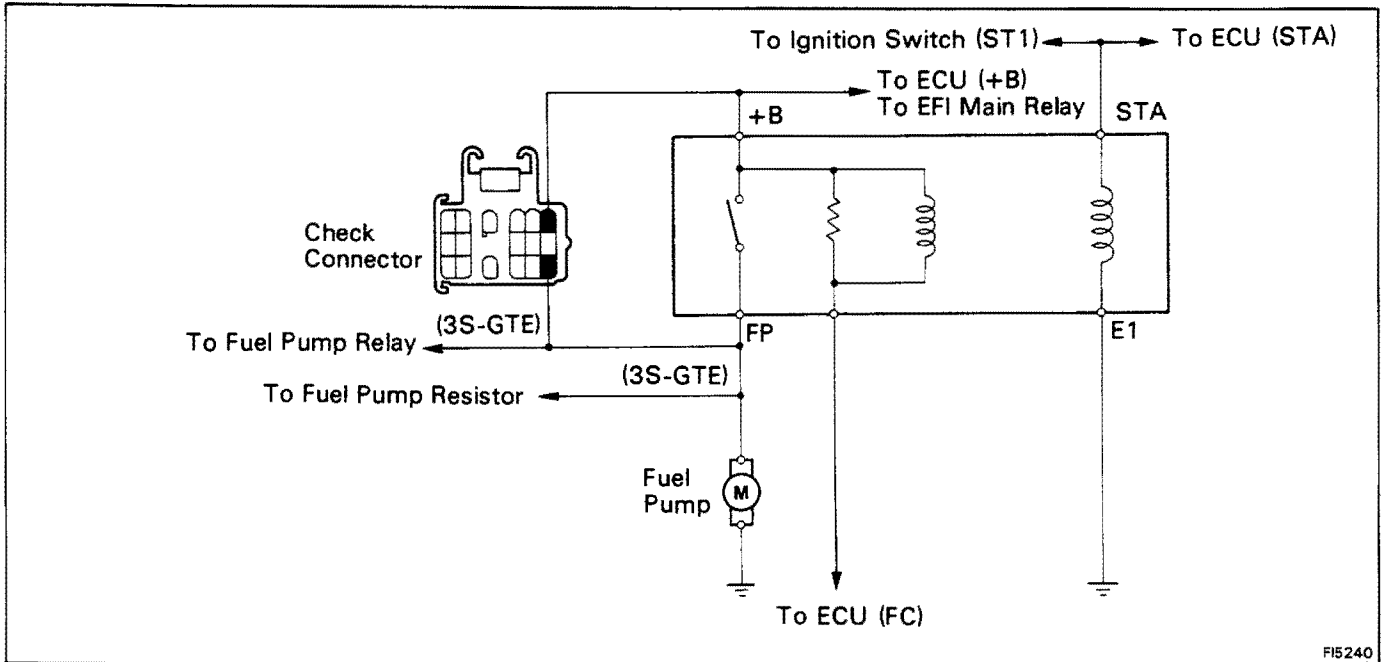

## INSPECTION OF CIRCUIT OPENING RELAY

### 1. INSPECT RELAY CONTINUITY

- (a) Using an ohmmeter, check that there is continuity between terminals STA and E1.
- (b) Check that there is continuity between terminals B and FC.
- (c) Check that there is no continuity between terminals B and FP.

If continuity is not as specified, replace the relay.

### 2. INSPECT RELAY OPERATION

- (a) Apply battery voltage across terminals STA and E1.
- (b) Using an ohmmeter, check that there is continuity between terminals B and FP.

- (c) Apply battery voltage across terminals B and FC.
- (d) Check that there is continuity between terminals B and FP.

If operation is not as specified, replace the relay.

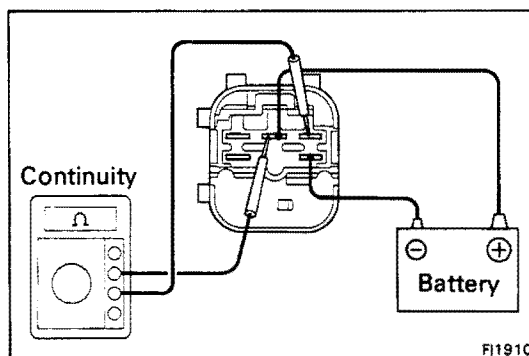
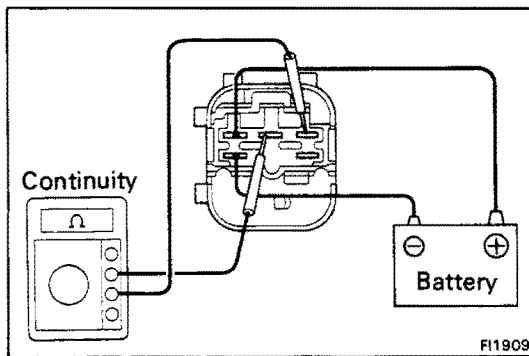
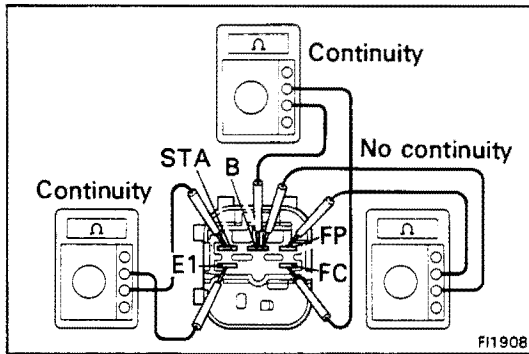

## Solenoid Resistor (3S-GTE only)

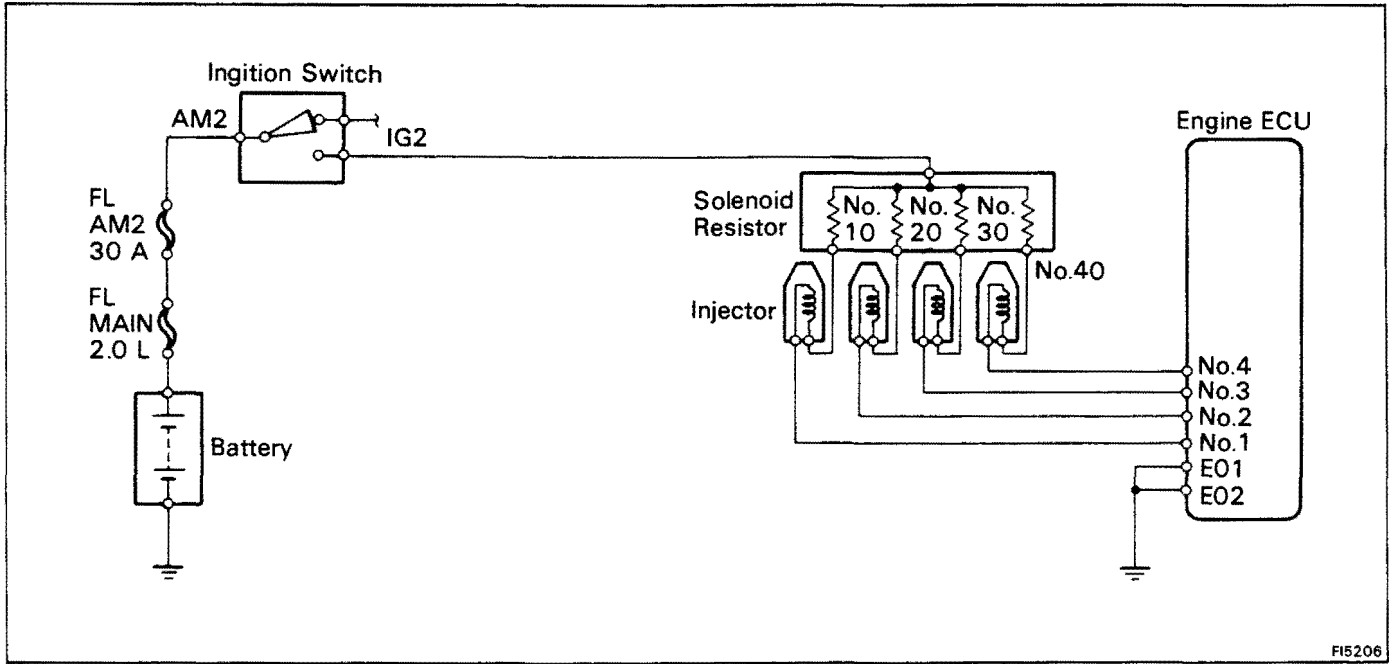

FI5206

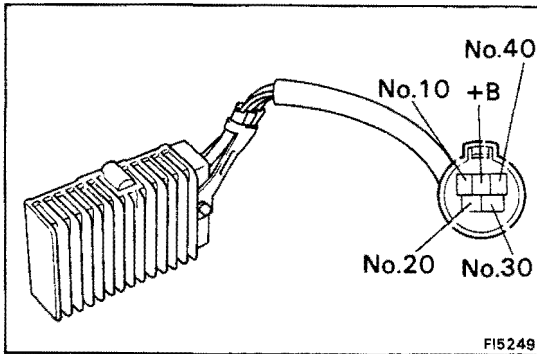

FI5249

### INSPECTION OF SOLENOID RESISTOR

#### INSPECT SOLENOID RESISTOR

Using an ohmmeter, measure the resistance between terminal +B and other terminals.

**Resistance: 4 – 6 Ω each**

If the resistance is not as specified, replace the resistor.

## Cold Start Injector Time Switch

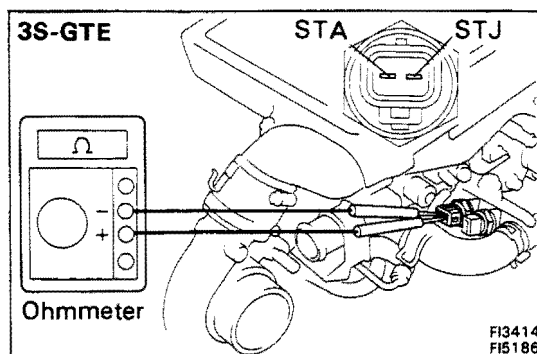
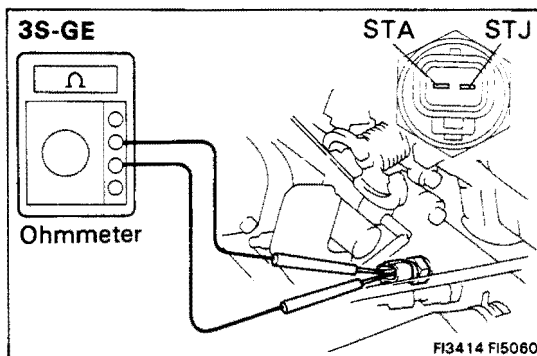
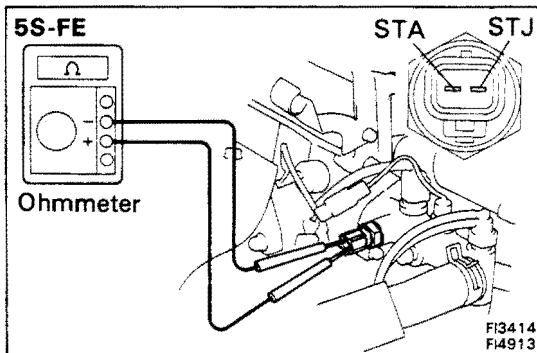
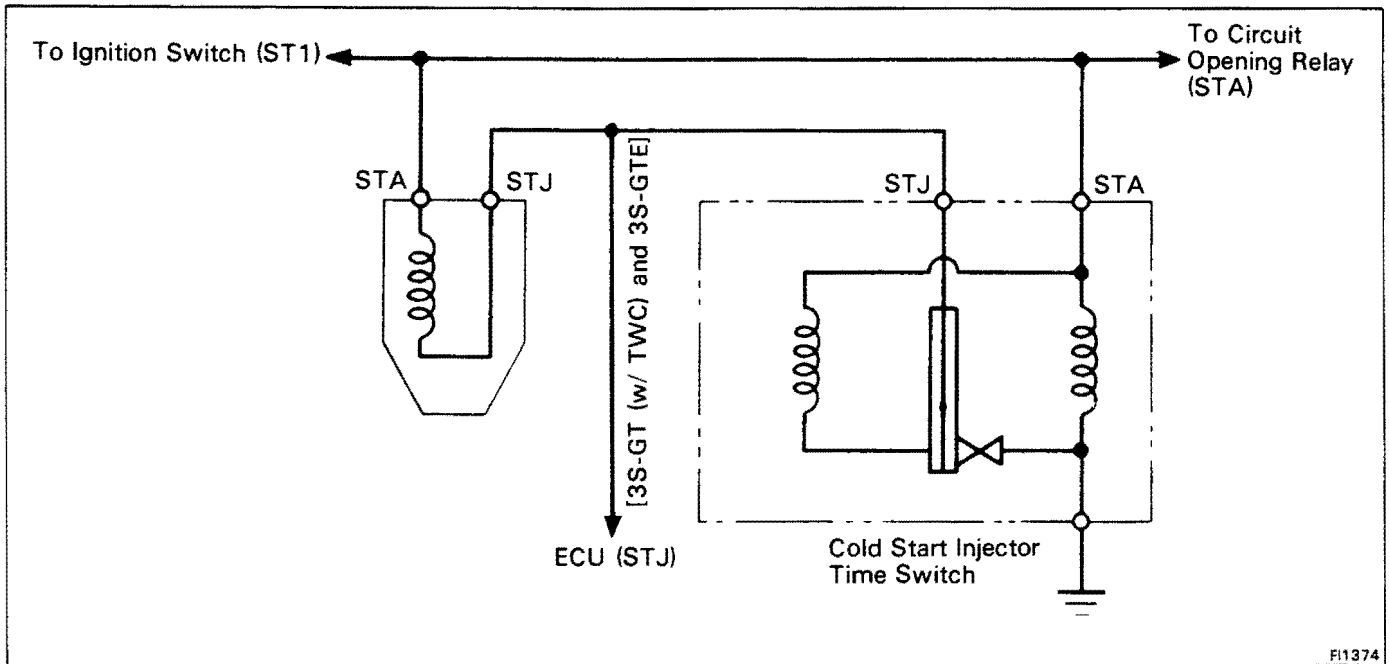

### INSPECTION OF COLD START INJECTOR TIME SWITCH

#### INSPECT RESISTANCE OF COLD START INJECTOR TIME SWITCH

Using an ohmmeter, measure the resistance between each terminal.

**Resistance:**

**5S-FE**

STA - STJ

20 - 40  $\Omega$  below 30° (86°F)

40 - 60  $\Omega$  above 40° (104°F)

STA - Ground

20 - 80  $\Omega$

**3S-GE (w/o TWC)**

STA - STJ

25 - 45  $\Omega$  below 15° (59°F)

65 - 85  $\Omega$  above 30° (86°F)

STA - Ground

25 - 85  $\Omega$

**3S-GE (w/ TWC) and 3S-GTE**

STA - STJ

30 - 50  $\Omega$  below 10° (50°F)

70 - 90  $\Omega$  above 25° (77°F)

STA - Ground

30 - 90  $\Omega$

If the resistance is not as specified, replace the switch.

# Water Temperature Sensor

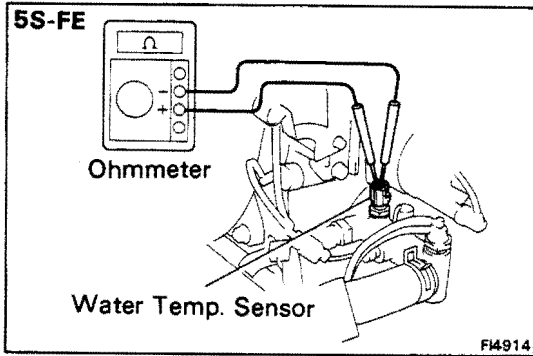
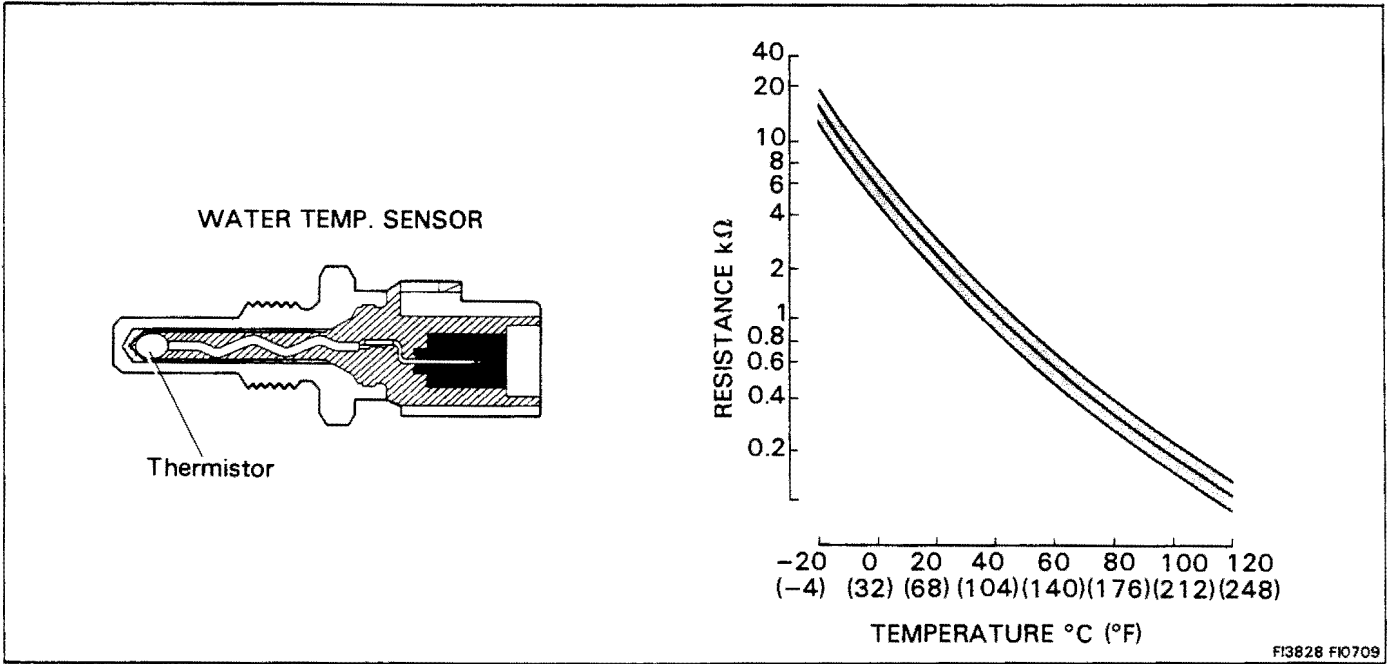

## INSPECTION OF WATER TEMPERATURE SENSOR

### INSPECT RESISTANCE OF WATER TEMPERATURE SENSOR

Using an ohmmeter, measure the resistance between the terminals.

**Resistance: Refer to chart**

If the resistance is not as specified, replace the sensor.

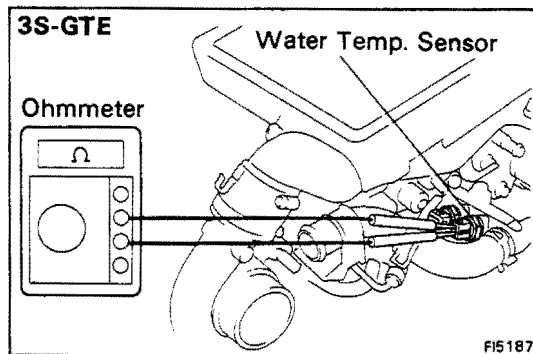
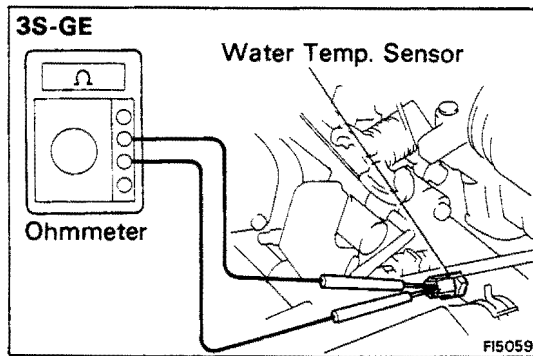

## Fuel Pump Relay and Resistor (3S-GTE only)

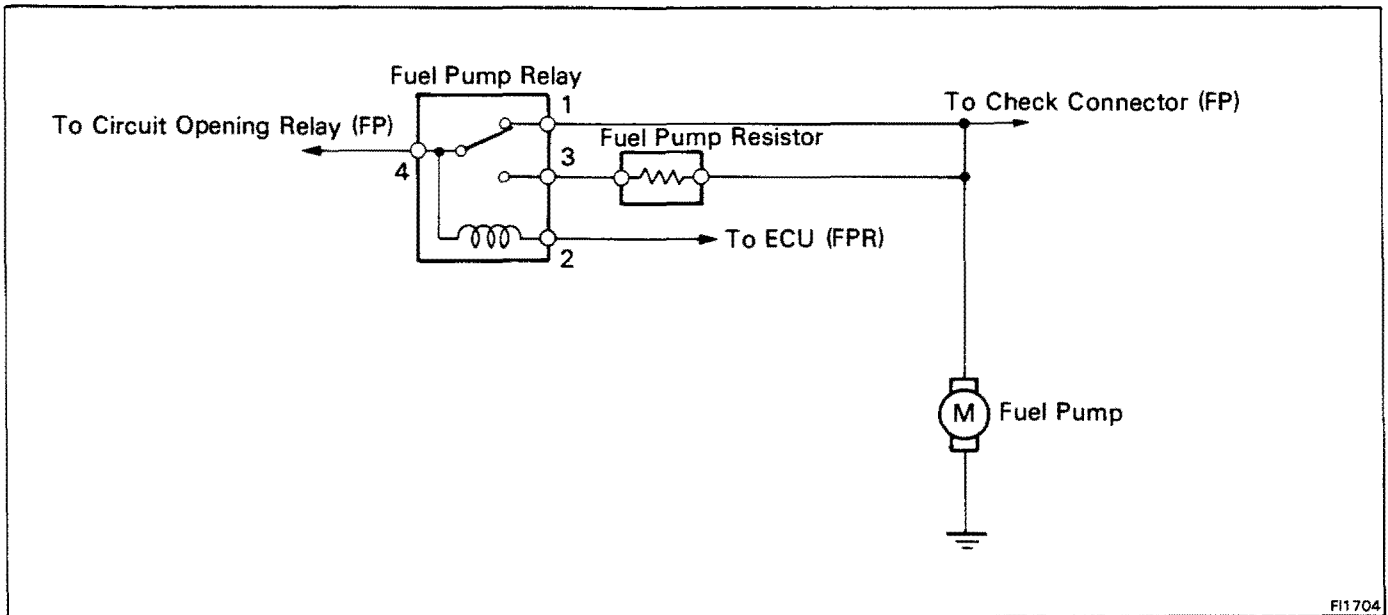

FI1704

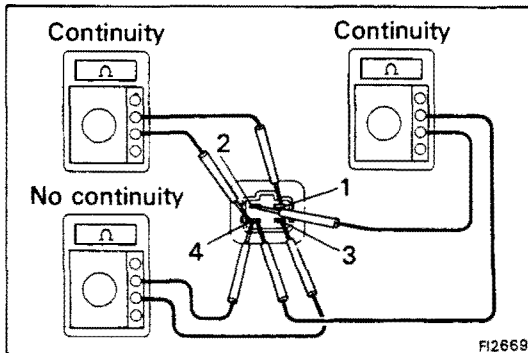

FI2669

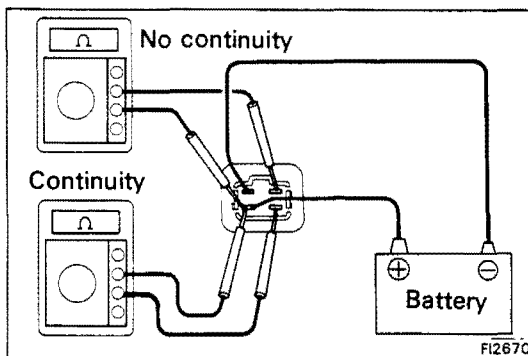

FI2670

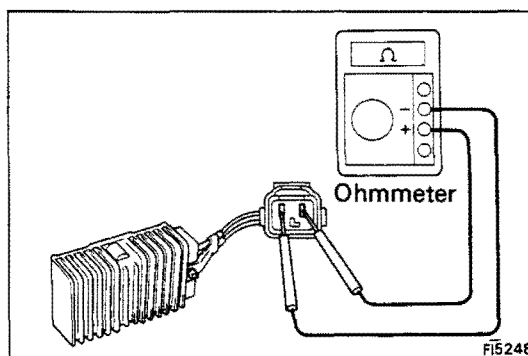

FI5248

### INSPECTION OF FUEL PUMP RELAY AND RESISTOR

#### 1. INSPECT FUEL PUMP RELAY

##### A. Inspect relay continuity

- Using an ohmmeter, check that there is continuity between terminals 1 and 4.
- Check that there is continuity between terminals 2 and 4.
- Check that there is no continuity between terminals 3 and 4.

If continuity is not as specified, replace the relay.

##### B. Inspect relay operation

- Apply battery voltage across terminals 2 and 4.
- Using an ohmmeter, check that there is no continuity between terminals 1 and 4.
- Check that there is continuity between terminals 3 and 4.

If operation is not as specified, replace the relay.

#### 2. INSPECT FUEL PUMP RESISTOR

Using an ohmmeter, measure the resistance between terminals.

**Resistance: Approx. 0.73  $\Omega$**

If the resistance is not as specified, replace the resistor.



# Intake Air Temperature Sensor (5S-FE and 3S-GE only)

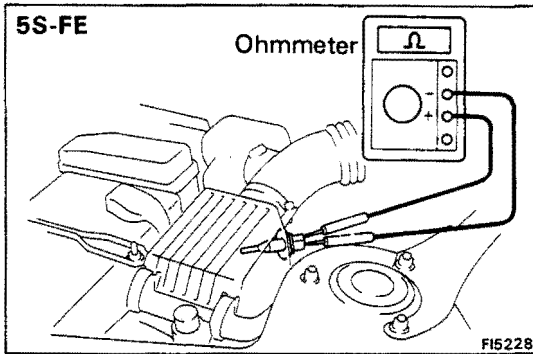
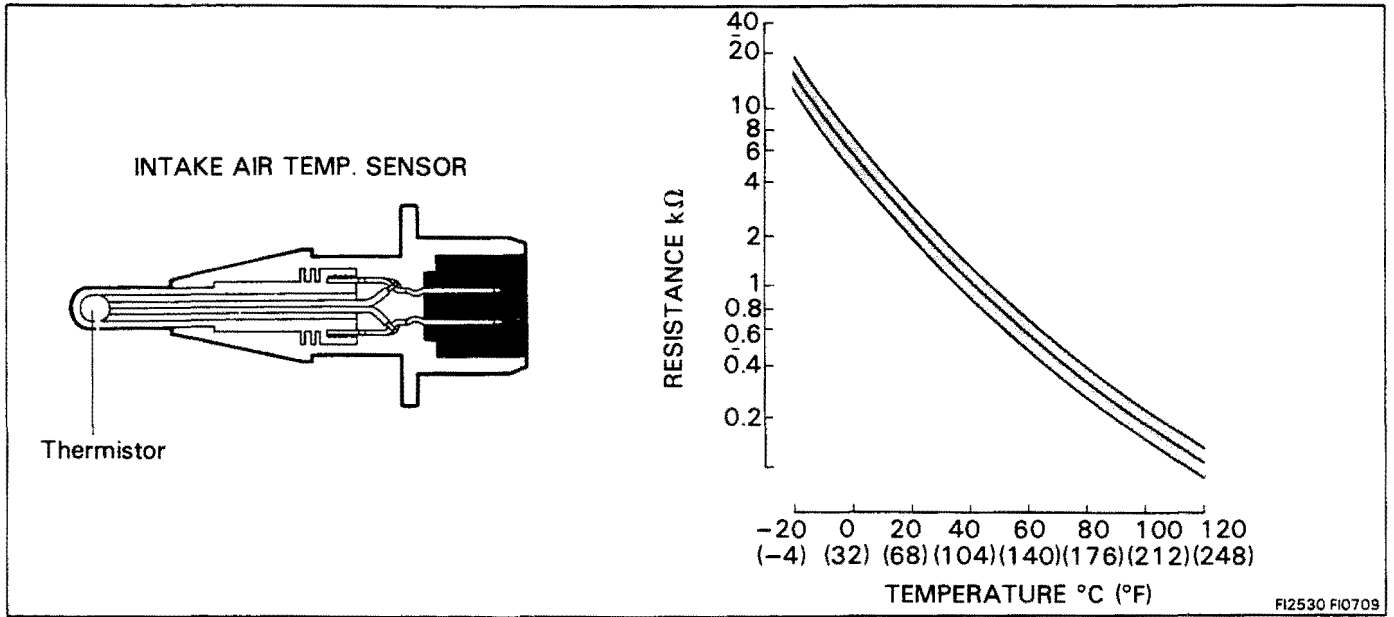

## INSPECTION OF INTAKE AIR TEMPERATURE SENSOR

### INSPECT RESISTANCE OF INTAKE AIR TEMPERATURE SENSOR

Using an ohmmeter, measure the resistance between the terminals.

**Resistance:** Refer to chart

If the resistance is not as specified, replace the sensor.

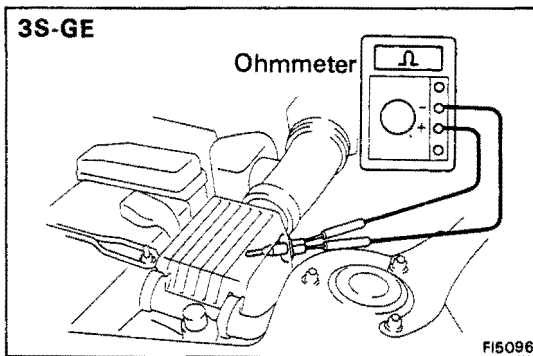

## Vacuum Sensor (5S-FE and 3S-GE only) (Manifold Absolute Pressure Sensor)

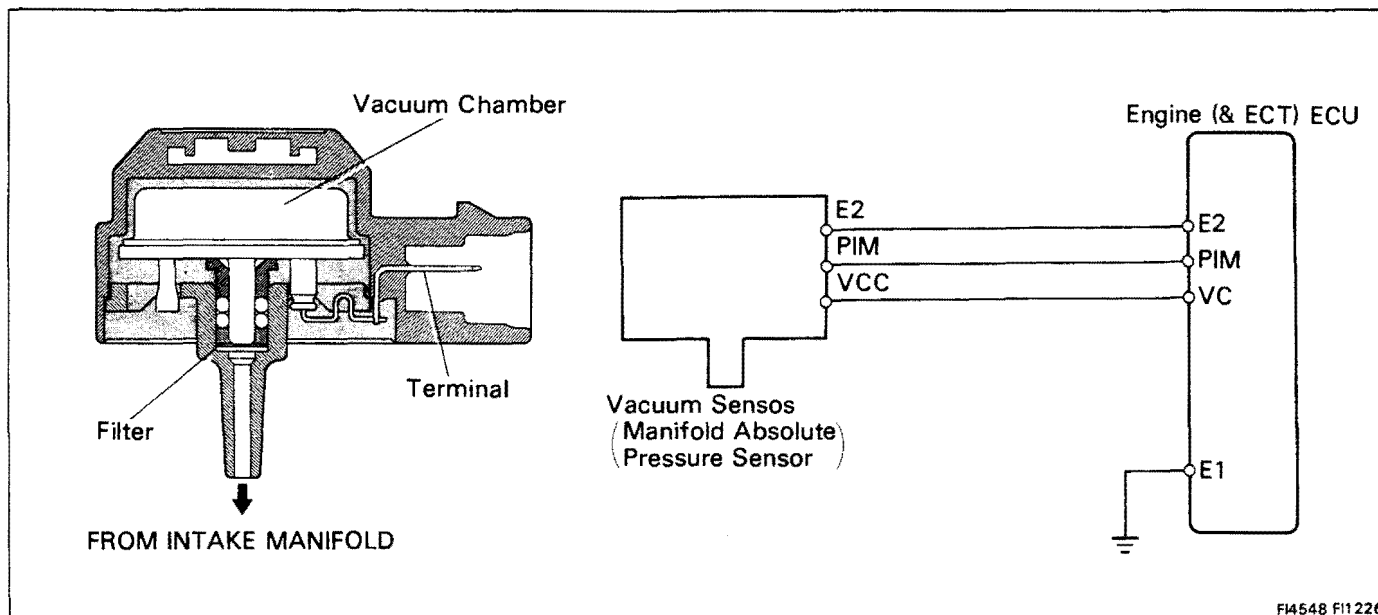

FI4548 FI1226

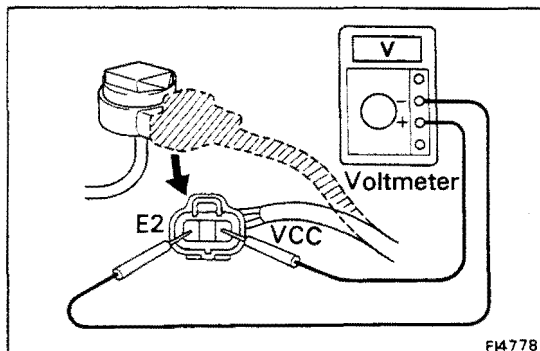

FI4778

### INSPECTION OF VACUUM SENSOR

#### 1. INSPECT POWER SOURCE VOLTAGE OF VACUUM SENSOR

- (a) Disconnect the vacuum sensor connector.
- (b) Turn the ignition switch ON.
- (c) Using a voltmeter, measure the voltage between terminals VCC and E2 of the vacuum sensor connector.

**Voltage: 4 – 6 V**

- (d) Reconnect the vacuum sensor connector.

#### 2. INSPECT POWER OUTPUT OF VACUUM SENSOR

- (a) Turn the ignition switch ON.
- (b) Disconnect the vacuum hose on the air intake manifold (chamber) side.
- (c) Connect a voltmeter to terminals PIM and E2 of the engine (and ECT) ECU, and measure the record of the output voltage under ambient atmospheric pressure.
- (d) Apply vacuum to the vacuum sensor in 100 mmHg (3.94 in.Hg, 13.3 kPa) segments to 500 mmHg (19.69 in.Hg, 66.7 kPa).
- (e) Measure the voltage drop from step (c) above for each segment.

**Voltage drop**

Applied Vacuum mmHg (in.Hg, kPa)	100 (3.94 13.3)	200 (7.87 26.7)	300 (11.81 40.0)	400 (15.75 53.3)	500 (19.69 66.7)
Voltage drop (V)	0.3 – 0.5	0.7 – 0.9	1.1 – 1.3	1.5 – 1.7	1.9 – 2.1

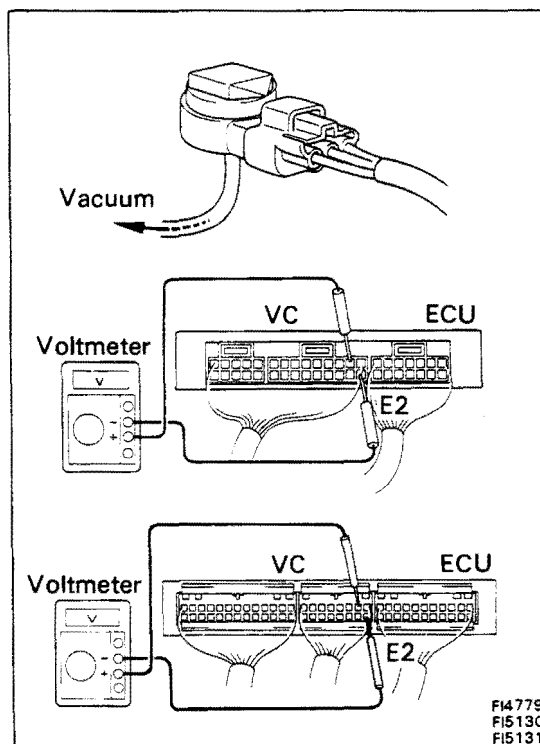

FI4779  
 FI5130  
 FI5131

## Variable Resistor (3S-GE (w/o TWC) only)

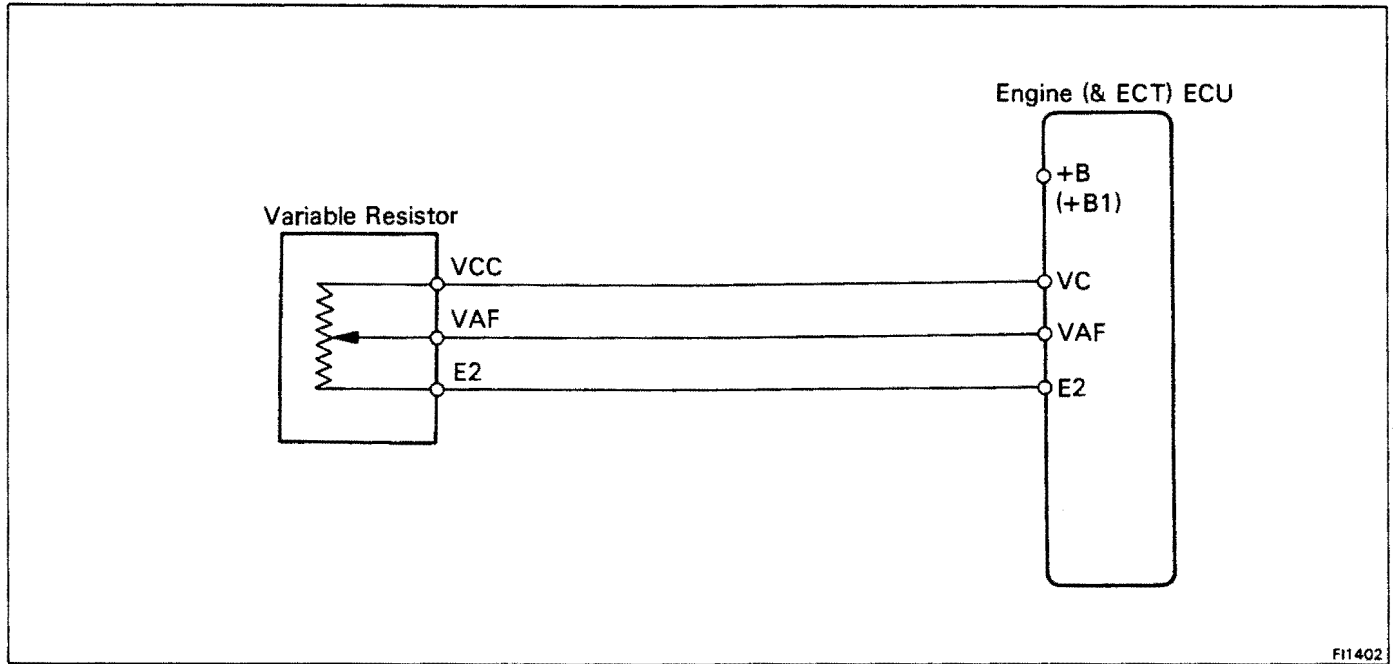

FI1402

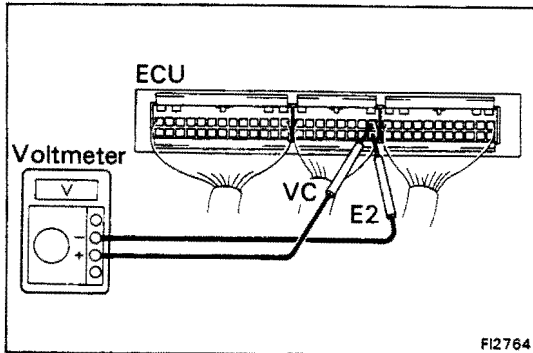

FI2764

### INSPECTION OF VARIABLE RESISTOR

#### 1. INSPECT POWER SOURCE VOLTAGE OF VARIABLE RESISTOR

- (a) Disconnect the variable resistor connector.
- (b) Turn the ignition switch ON.
- (c) Using a voltmeter, measure the voltage between terminals VCC and E2 of the variable resistor.

**Voltage: 4 – 6 V**

- (d) Reconnect the variable resistor connector.

#### 2. INSPECT POWER OUTPUT OF VARIABLE RESISTOR

- (a) Turn the ignition switch ON.
- (b) Measure the voltage between terminals VAF and E2 of the engine (and ECT) ECU while slowly turning idle mixture adjusting screw first fully counterclockwise, and then fully clockwise.
- (c) Check that voltage changes smoothly from 0 V to approx. 5 V.

**HINT:** There is not suddenly jump up to 5 V or down to 0 V.

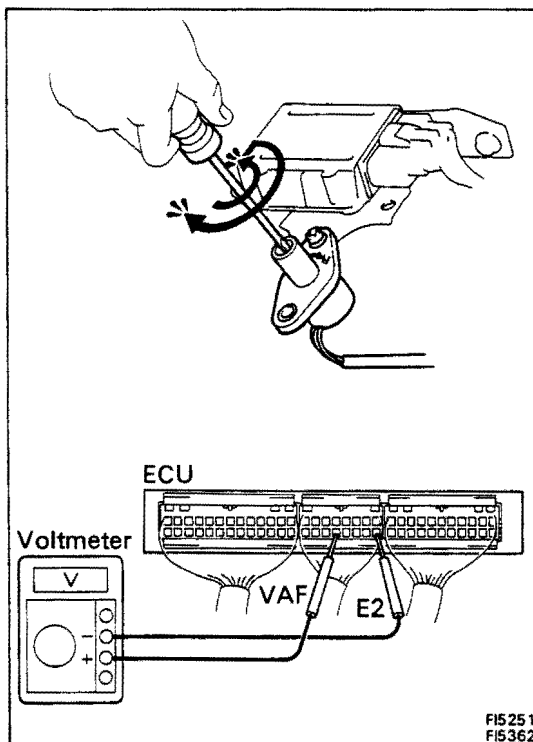

FI5251  
 FI5362

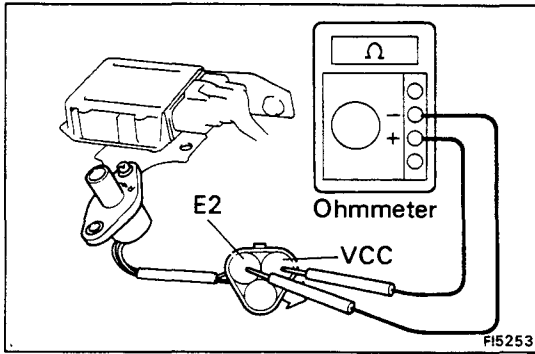

### 3. INSPECT RESISTANCE OF VARIABLE RESISTOR

- (a) Disconnect the variable resistor connector.
- (b) Using an ohmmeter, measure the resistance between terminals VCC and E2.

Resistance: 4 – 6 k $\Omega$

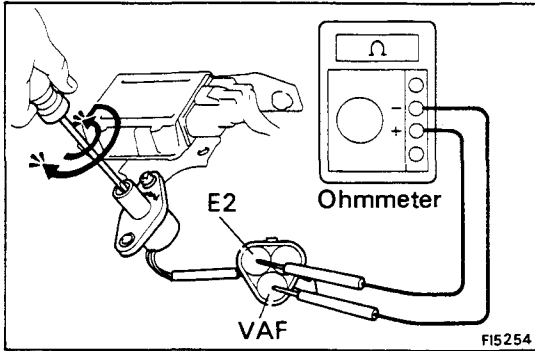

- (c) Turn the idle mixture adjusting screw fully counterclockwise.
- (d) Connect the ohmmeter probes to terminals VAF and E2. Turn the adjusting screw fully clockwise and check that the resistance value changes from approx. 5 k $\Omega$  to 0  $\Omega$  accordingly.
- (e) Reconnect the variable resistor connector.

# ACIS VSV (3S-GE only)

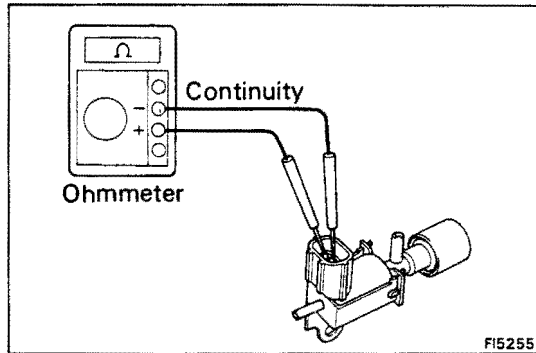
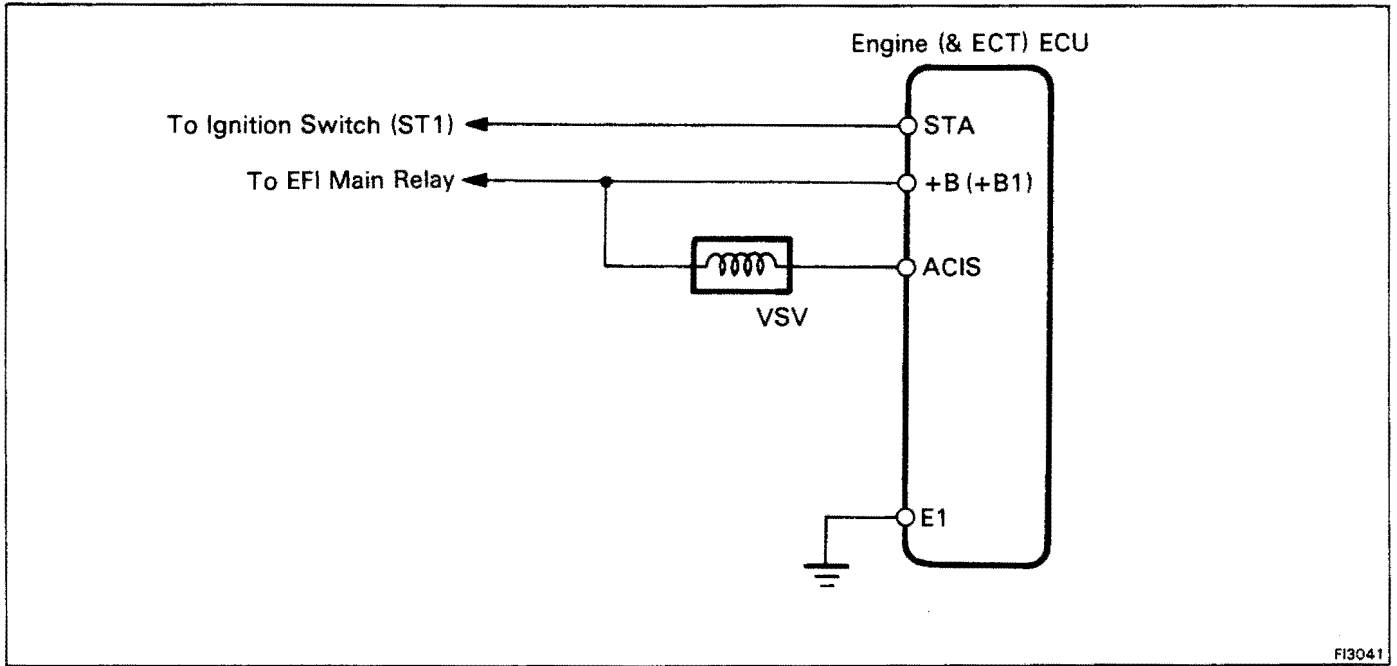

## INSPECTION OF ACIS VSV

### 1. INSPECT VSV FOR OPEN CIRCUIT

Using an ohmmeter, check that there is continuity between the terminals.

**Resistance (Cold): 33 – 39 Ω**

If there is no continuity, replace the VSV.

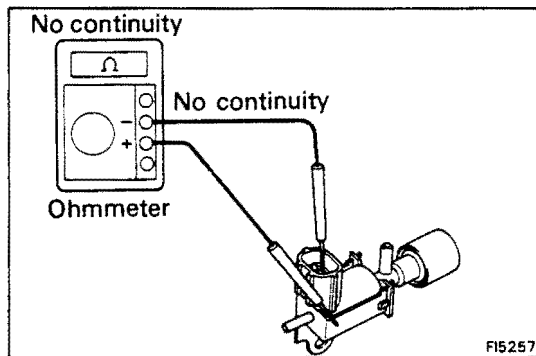

### 2. INSPECT VSV FOR GROUND

Using an ohmmeter, check that there is no continuity between each terminal and the body.

If there is continuity, replace the VSV.

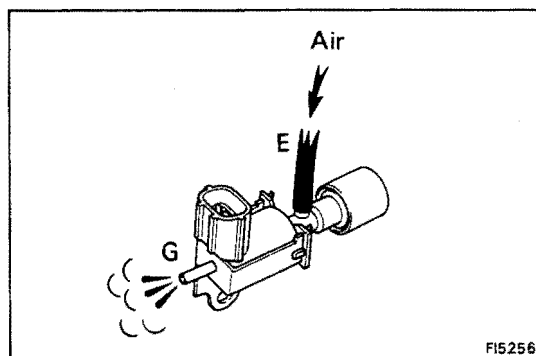

### 3. INSPECT VSV OPERATION

- (a) Check that air flow from pipes E to G.

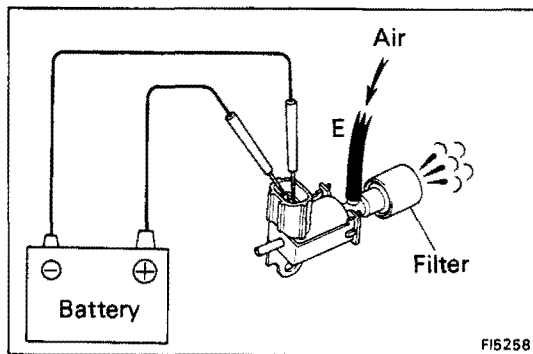

- (b) Apply battery voltage across the terminals.
  - (c) Check that air flows from pipe E to the filter.
- If operation is not as specified, replace the VSV.

## T-VIS VSV (3S-GTE only)

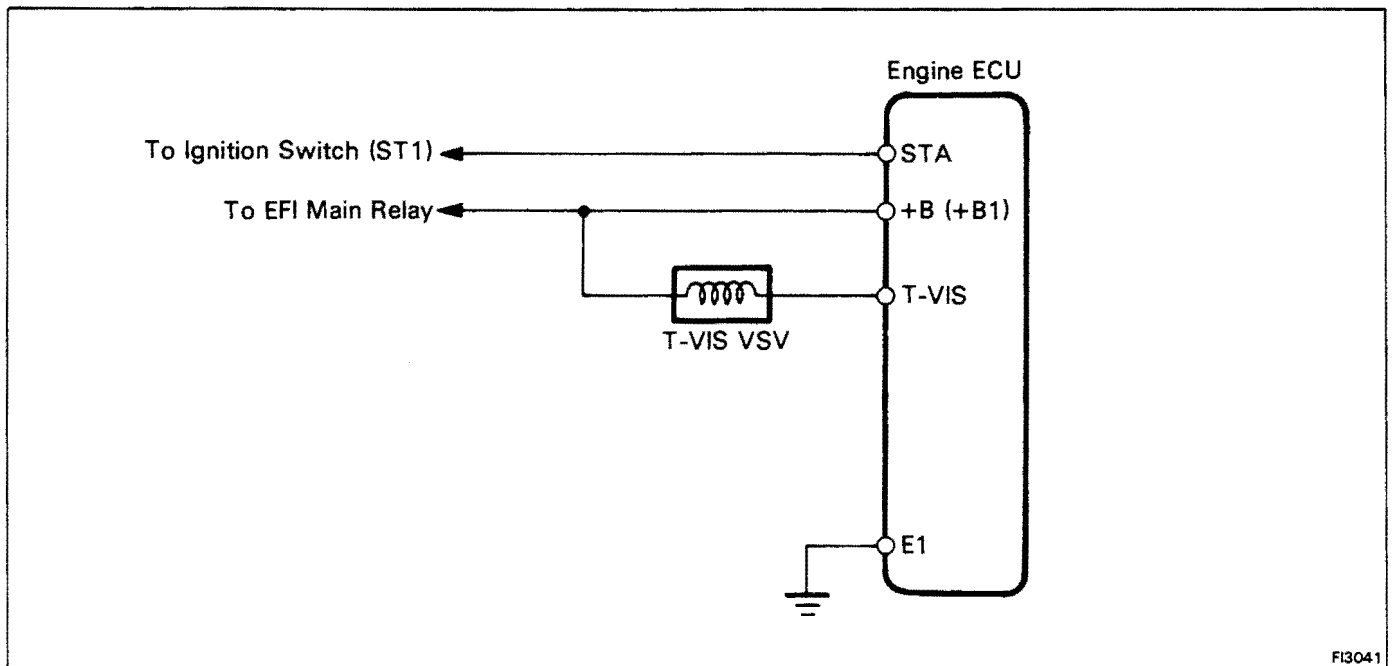

F13041

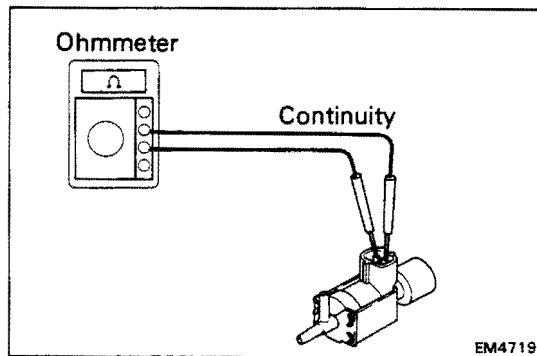

EM4719

### INSPECTION OF T-VIS VSV

#### 1. INSPECT VSV FOR OPEN CIRCUIT

Using an ohmmeter, check that there is continuity between the terminals.

**Resistance (Cold): 33 – 39 Ω**

If there is no continuity, replace the VSV.

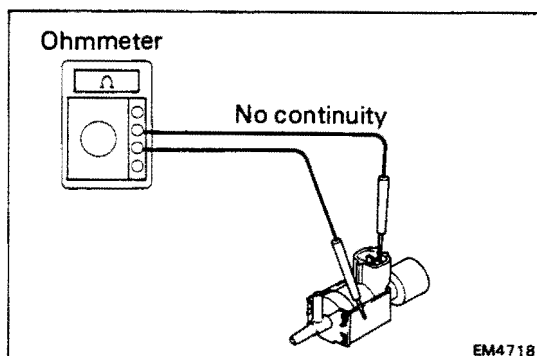

EM4718

#### 2. INSPECT VSV FOR GROUND

Using an ohmmeter, check that there is no continuity between each terminal and the body.

If there is continuity, replace the VSV.

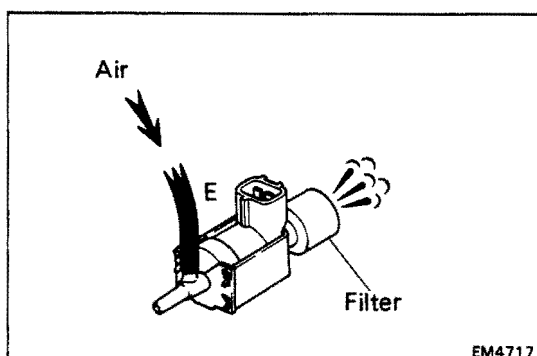

EM4717

#### 3. INSPECT VSV OPERATION

(a) Check that air flow from pipe E to the filter.

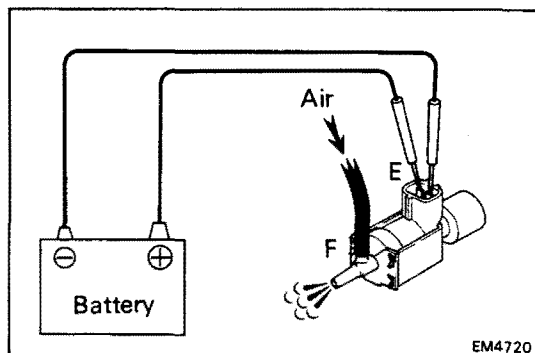

- (b) Apply battery voltage across the terminals.  
(c) Check that air flows from pipes E to F.  
If operation is not as specified, replace the VSV.



## EGR VSV (5S-FE and 3S-GTE only)

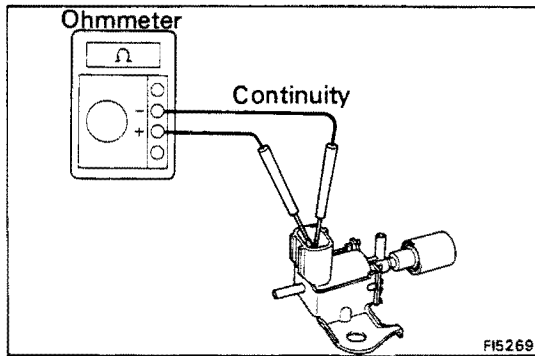
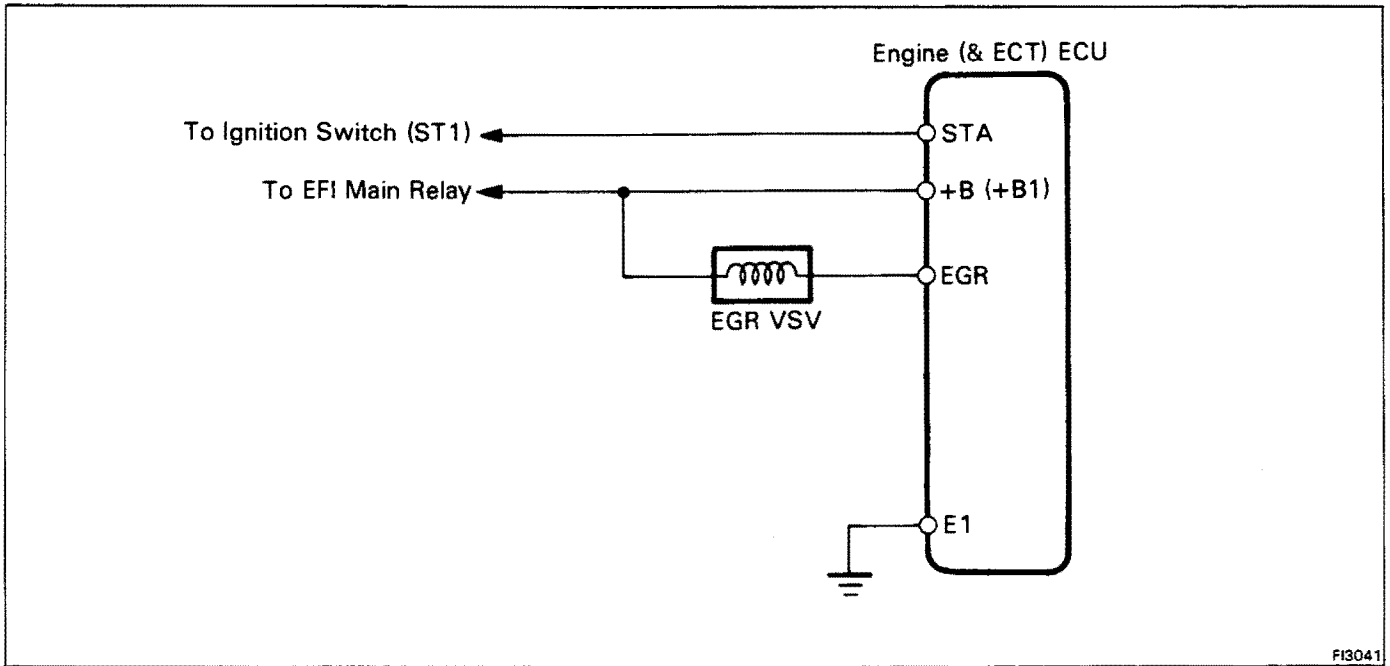

### INSPECTION OF EGR VSV (5S-FE)

#### 1. INSPECT VSV FOR OPEN CIRCUIT

Using an ohmmeter, check that there is continuity between the terminals.

**Resistance (Cold): 33 – 39 Ω**

If there is no continuity, replace the VSV.

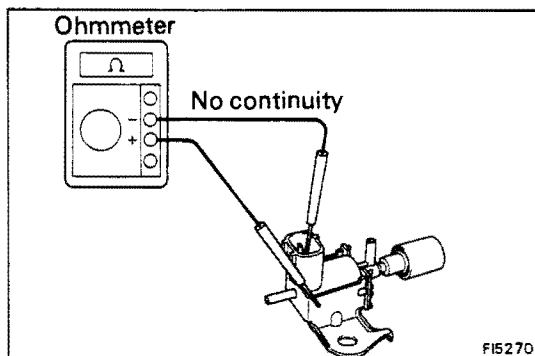

#### 2. INSPECT VSV FOR GROUND

Using an ohmmeter, check that there is no continuity between each terminal and the body.

If there is continuity, replace the VSV.

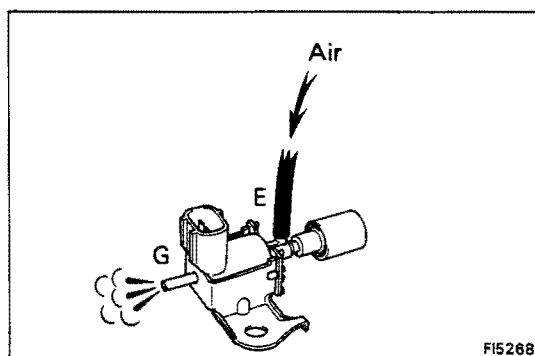

#### 3. INSPECT VSV OPERATION

- (a) Check that air flow from pipes E to G.

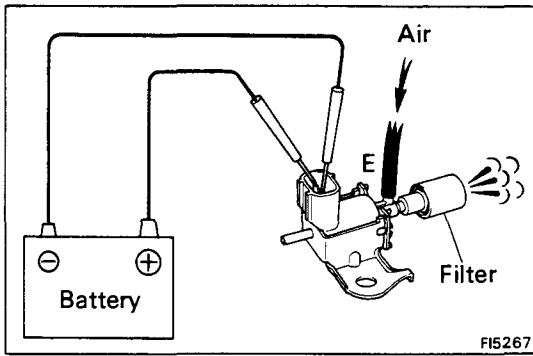

- (b) Apply battery voltage across the terminals.
  - (c) Check that air flows from pipe E to the filter.
- If operation is not as specified, replace the VSV.

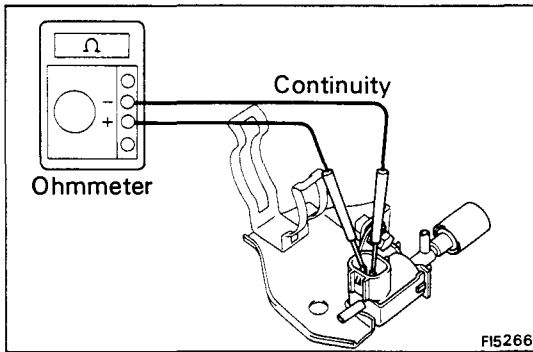

## INSPECTION OF EGR VSV (3S-GTE)

### 1. INSPECT VSV FOR OPEN CIRCUIT

Using an ohmmeter, check that there is continuity between the terminals.

**Resistance (Cold): 33 – 39 Ω**

If there is no continuity, replace the VSV.

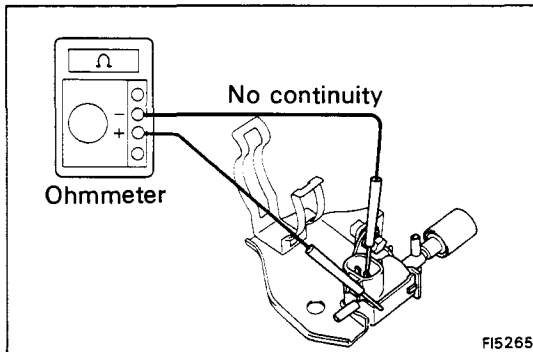

### 2. INSPECT VSV FOR GROUND

Using an ohmmeter, check that there is no continuity between each terminal and the body.

If there is continuity, replace the VSV.

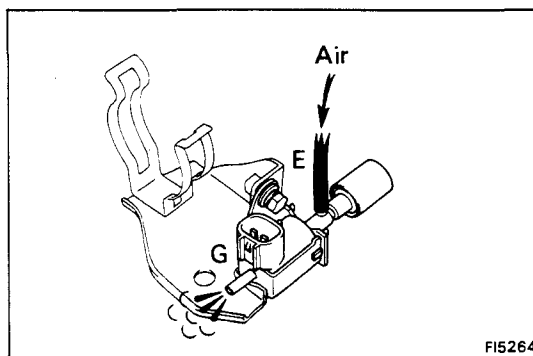

### 3. INSPECT VSV OPERATION

- (a) Check that air flow from pipe E to G.

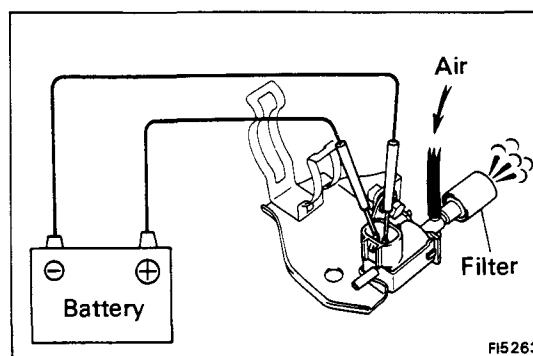

- (b) Apply battery voltage across the terminals.
  - (c) Check that air flows from pipe E to the filter.
- If operation is not as specified, replace the VSV.

# Turbocharging Pressure Sensor (3S-GTE only)

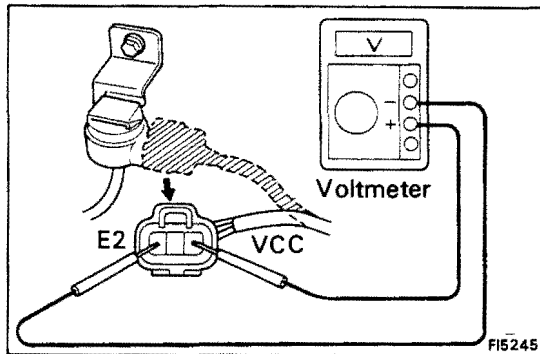
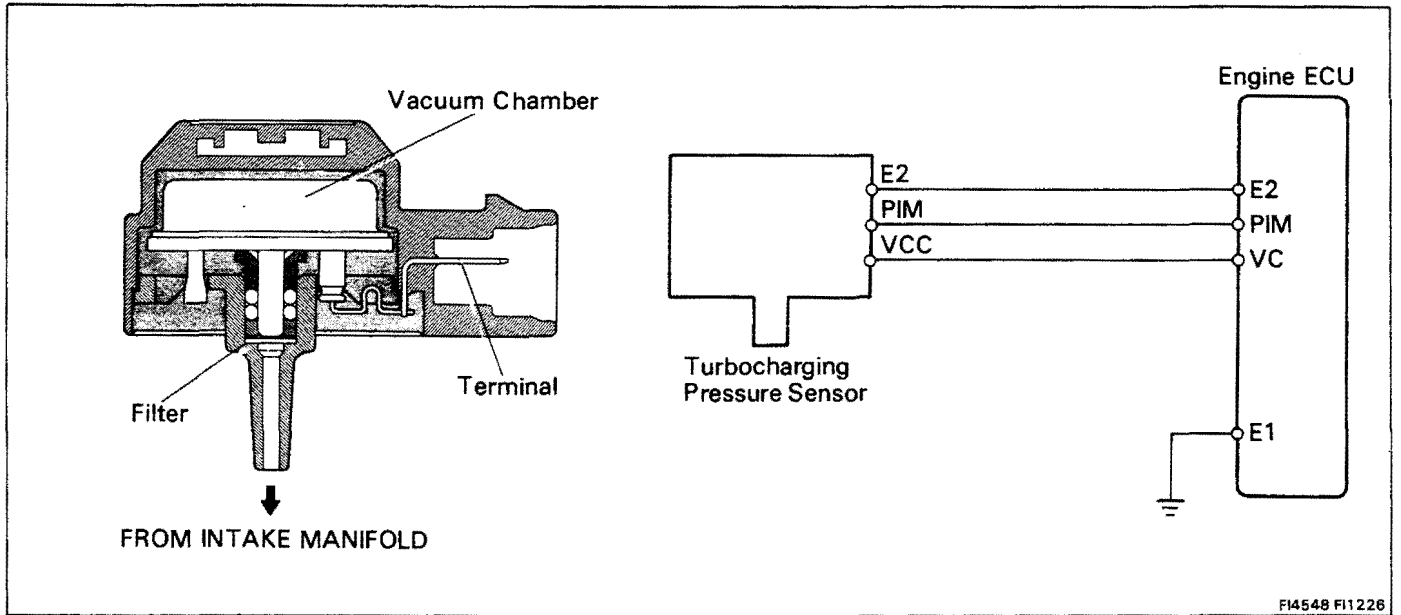

## INSPECTION OF TURBOCHARGING PRESSURE SENSOR

### 1. INSPECT POWER SOURCE VOLTAGE OF TURBOCHARGING PRESSURE SENSOR

- (a) Disconnect the turbocharging pressure sensor connector.
- (b) Turn the ignition switch ON.
- (c) Using a voltmeter, measure the voltage between terminals VCC and E2 of the vacuum sensor connector.

**Voltage: 4 – 6 V**

- (d) Reconnect the turbocharging pressure sensor connector.

### 2. INSPECT POWER OUTPUT OF TURBOCHARGING PRESSURE SENSOR

- (a) Turn the ignition switch ON.
- (b) Disconnect the vacuum hose of the air intake manifold (chamber) side.
- (c) Connect a voltmeter to terminals PIM and E2 of the pressure sensor, and measure and record the output voltage under ambient atmospheric pressure.
- (d) Apply vacuum to the pressure sensor in 100 mmHg (3.94 in.Hg, 13.3 kPa) segments to 500 mmHg (19.69 in.Hg, 66.7 kPa).
- (e) Measure the voltage drop from step (c) above for each segment.

**Voltage drop**

Applied Vacuum mmHg (in.Hg, kPa)	100 (3.94 13.3)	200 (7.87 26.7)	300 (11.81 40.0)	400 (15.75 53.3)	500 (19.69 66.7)
Voltage drop (V)	0.15 – 0.35	0.4 – 0.6	0.65 – 0.85	0.9 – 1.1	1.15 – 1.35

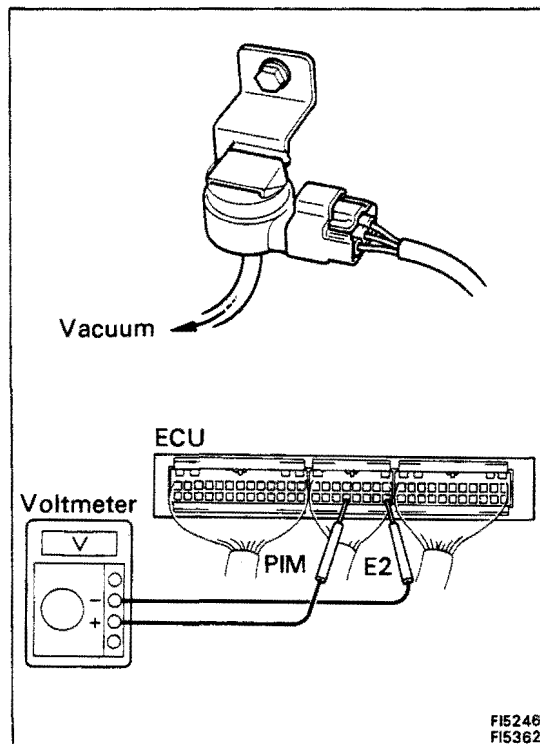

## Turbocharging pressure VSV (3S-GTE only)

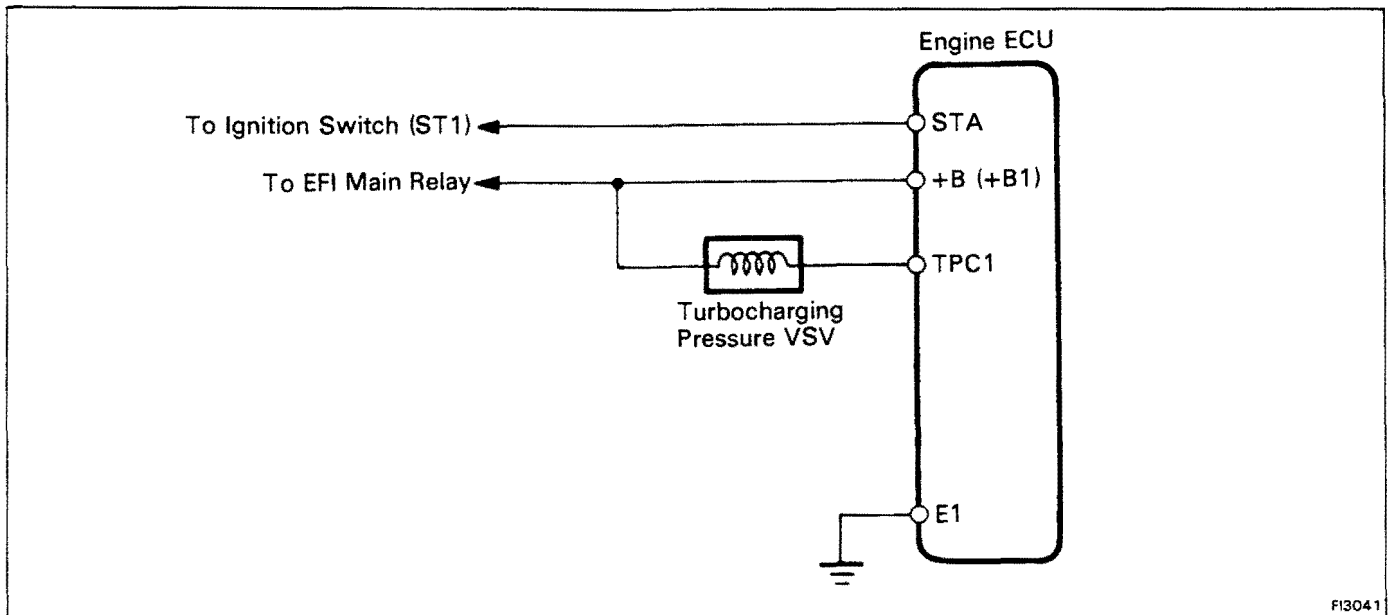

FI3041

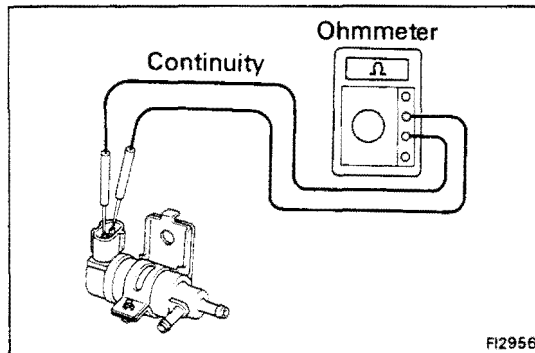

FI2956

### INSPECTION OF TURBOCHARGING PRESSURE VSV

#### 1. INSPECT VSV FOR OPEN CIRCUIT

Using an ohmmeter, check that there is continuity between the terminals.

**Resistance (Cold): 24 – 30 Ω**

If there is no continuity, replace the VSV.

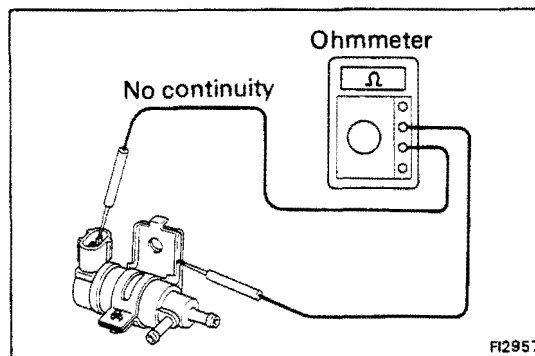

FI2957

#### 2. INSPECT VSV FOR GROUND

Using an ohmmeter, check that there is no continuity between each terminal and the body.

If there is continuity, replace the VSV.

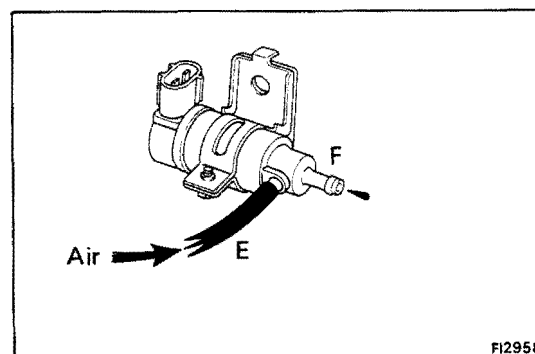

FI2958

#### 3. INSPECT VSV OPERATION

- (a) Check that air does not flow from pipes E to F.

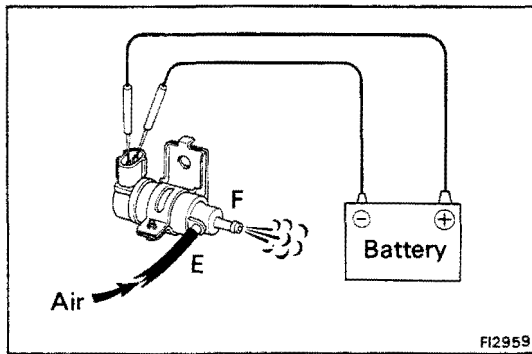

- (b) Apply battery voltage across the terminals.
  - (c) Check that air flows from pipes E to F.
- If operation is not as specified, replace the VSV.

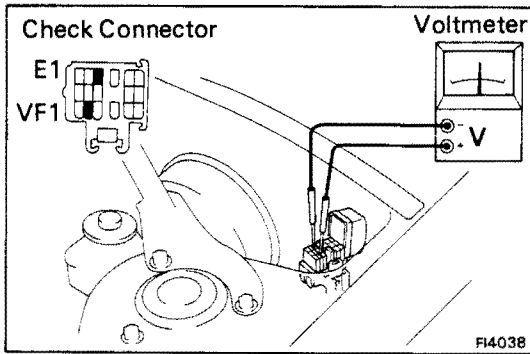

# Oxygen Sensor (w/ TWC only)

## INSPECTION OF OXYGEN SENSOR

### 1. WARM UP ENGINE

Allow the engine to reach normal operating temperature.

### 2. INSPECT FEEDBACK VOLTAGE

Connect the positive (+) probe of a voltmeter to terminal VF1 of the check connector, and negative (-) probe to terminal E1. Perform the test as follows:

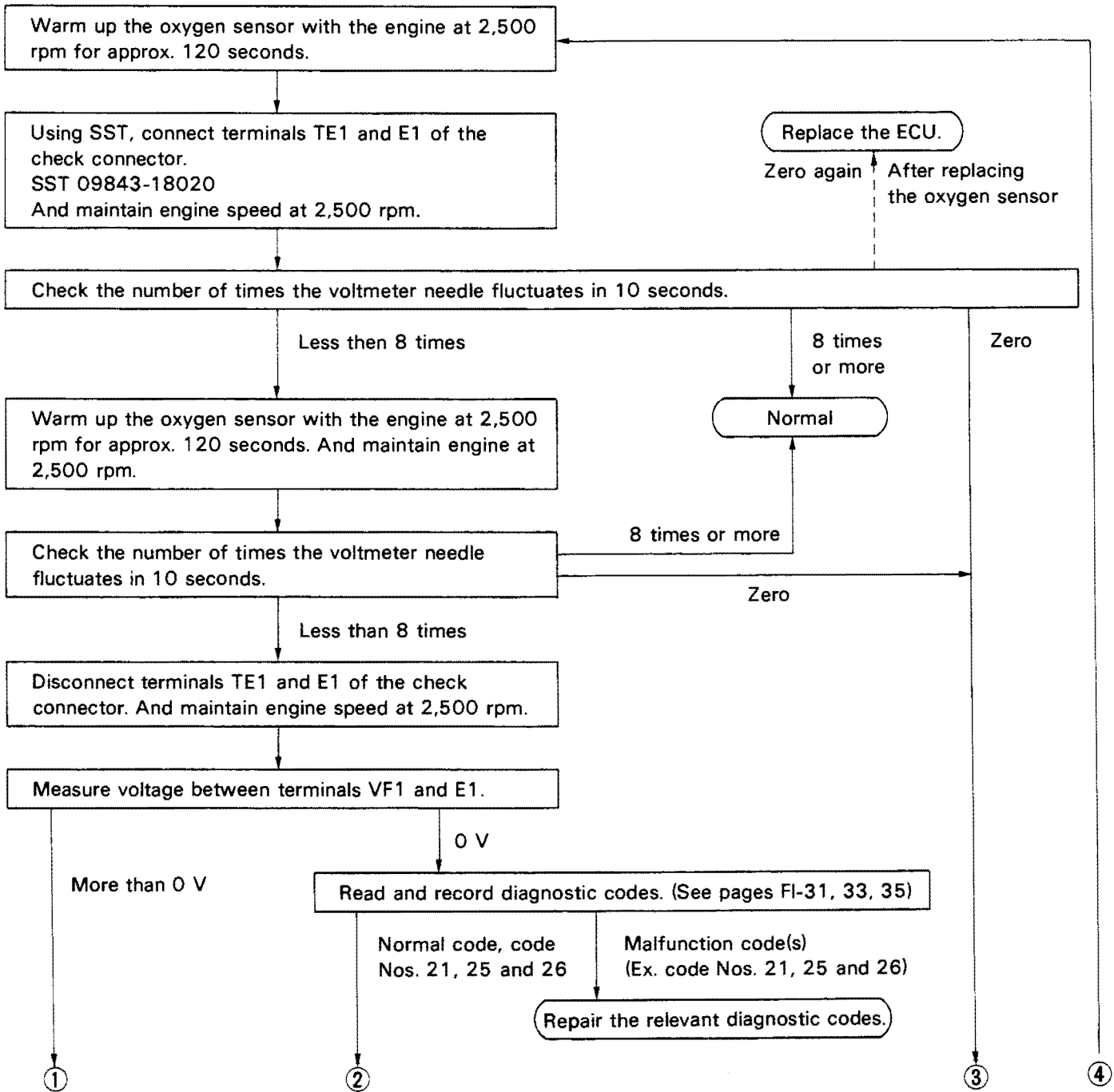

CONTINUED ON PAGE FI-202

CONTINUED FROM PAGE FI-201

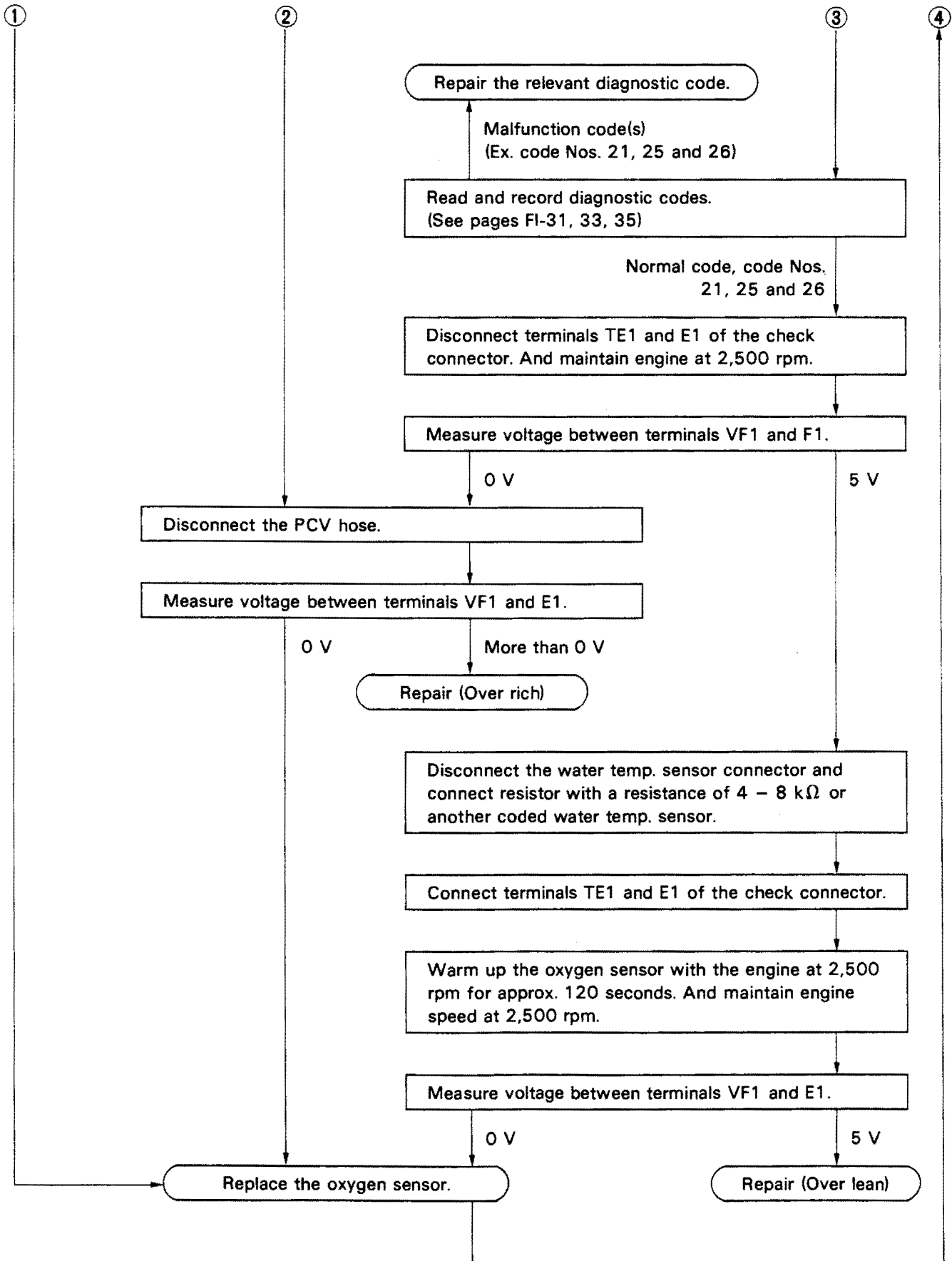

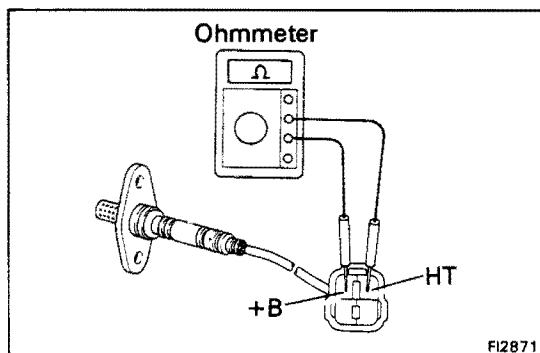
**3. (3S-GE and 3S-GTE only.)****INSPECT HEATER RESISTANCE OF OXYGEN SENSOR**

Using an ohmmeter, measure the resistance between the terminal +B and HT.

**Resistance (Cold): 5.1 – 6.3  $\Omega$  at 20°C (68°F)**

If the resistance is not as specified, replace the sensor.



# Engine (and ECT) Electronic Controlled Unit (ECU)

## INSPECTION OF ENGINE (AND ECT) ECU

**HINT:** The EFI circuit can be checked by measuring the resistance and voltage at the wiring connectors of the engine (and ECT) ECU.

### 1. INSPECT VOLTAGE OF ENGINE (AND ECT) ECU

Check the voltage between each terminal of the wiring connectors.

- Turn the ignition switch ON.
- Measure the voltage at each terminal.

**HINT:**

- Perform all voltage measurements with the connectors connected.
- Verify that the battery voltage is 11 V or more when the ignition switch is ON.

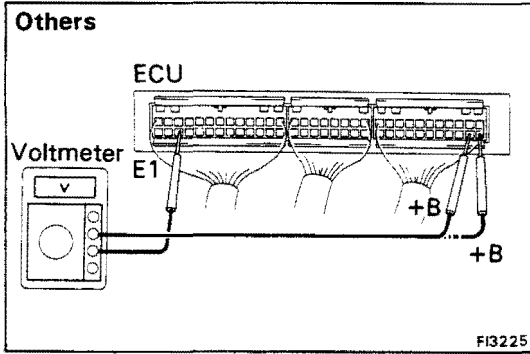
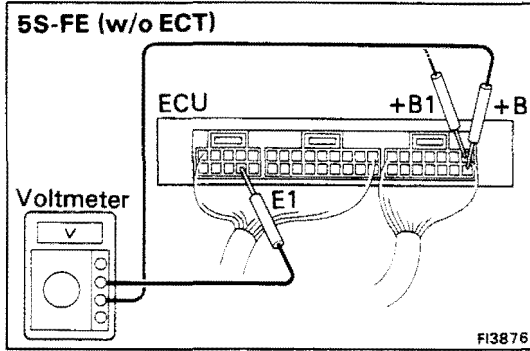

### Voltage at Engine ECU Wiring Connectors (5S-FE (w/o ECT))

Terminals	Condition		STD voltage (V)
+B +B1 - E1	IG SW ON		10 - 14
BATT - E1	-		10 - 14
IDL - E1	IG SW ON	Throttle valve open	8 - 14
PSW - E1		Throttle valve fully closed (Throttle opener must be cancelled first)	4 - 6
VC - E2	IG SW ON		4 - 6
PIM - E2			2.5 - 4.5
No.10 E01 No.20 E02	IG SW ON		10 - 14
THA - E2	IG SW ON	Intake air temp. 20°C (68°F)	1 - 3
THW - E2	IG SW ON	Coolant temp. 80°C (176°F)	0.1 - 1.0
STA - E1	Cranking		6 - 14
IGT - E1	Idling		0.7 - 1.0
ISCC ISCO - E1	IG SW ON	Engine ECU connectors disconnected	8 - 14
W - E1	No trouble ("CHECK" engine warning light off) and engine running		10 - 14
A/C - E1	IG SW ON	Air conditioning ON	8 - 14
T - E1	IG SW ON	Check connector TE1 - E1 not connect	10 - 14
		Check connector TE1 - E1 connect	1 or less
NSW - E1	IG SW ON	Shift position P or N range	0 - 2
		Ex. shift position P or N range	6 - 14
B/K - E1	Stop light SW ON (Brake pedal depressed)		10 - 14

**Engine ECU Terminals**

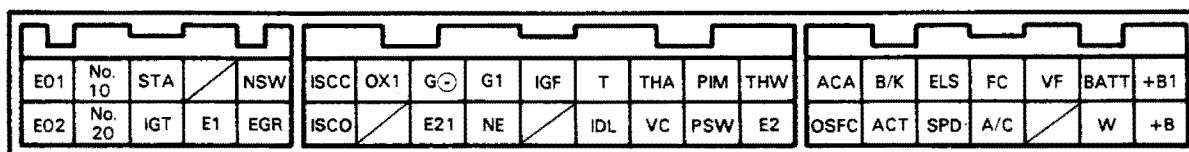

**Voltage at Engine (and ECT) ECU  
 Wiring Connectors (5S-FE (w/ ECT))**

Terminals	Condition		STD voltage (V)
+B +B1 - E1	IG SW ON		10 - 14
BATT - E1	-		10 - 14
IDL - E2	IG SW ON	Throttle valve open	8 - 14
VTA - E2		Throttle valve fully closed (Throttle opener must be cancelled first)	0.1 - 1.0
		Throttle valve open	4 - 5
VC - E2	IG SW ON		4 - 6
PIM - E2			2.5 - 4.5
No.10 - E01 No.20 - E02	IG SW ON		10 - 14
THA - E2	IG SW ON	Intake air temp. 20°C (68°F)	1 - 3
THW - E2	IG SW ON	Coolant temp. 80°C (176°F)	0.1 - 1.0
STA - E1	Cranking		6 - 14
IGT - E1	Idling		0.7 - 1.0
ISCC - E1 ISCO - E1	IG SW ON	Engine and ECT ECU connectors disconnected	8 - 14
W - E1	No trouble ("CHECK" engine warning light off) and engine running		10 - 14
A/C - E1	IG SW ON	Air conditioning ON	8 - 14
T - E1	IG SW ON	Check connector TE1 - E1 not connect	10 - 14
		Check connector TE1 - E1 connect	1 or less
NSW - E1	IG SW ON	Shift position P or N range	0 - 2
		Ex. shift position P or N range	6 - 14
B/K - E1	Stop light SW ON (Brake pedal depressed)		10 - 14

**Engine and ECT ECU Terminals**

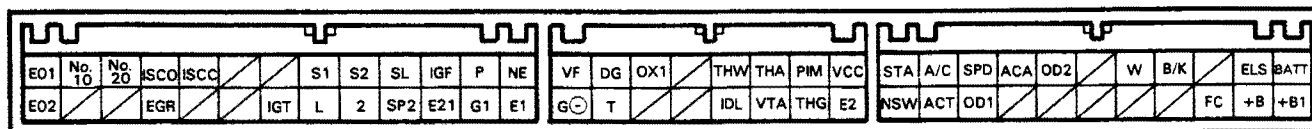

### Voltage at Engine ECU Wiring Connectors (3S-GE)

Terminals	Condition		STD voltage (V)
+B +B1 - E1	IG SW ON		10 - 14
BATT - E1	-		10 - 14
IDL - E2	IG SW ON	Throttle valve open	4 - 6
VTA - E2		Throttle valve fully closed	0.1 - 1.0
		Throttle valve open	4 - 5
VC - E2	IG SW ON		4 - 6
PIM - E2			2.5 - 4.5
No.1 No.2 - E01 No.3 - E02 No.4	IG SW ON		10 - 14
THA - E2	IG SW ON	Intake air temp. 20°C (68°F)	1 - 3
THW - E2	IG SW ON	Coolant temp. 80°C (176°F)	0.1 - 1.0
STA - E1	Cranking		6 - 14
IGT - E1	Idling		0.7 - 1.0
RSC RSO - E1	IG SW ON	Engine (and ECT) ECU connectors disconnected	8 - 14
W - E1	No trouble ("CHECK" engine warning light off) and engine running		10 - 14
AC1 - E1	IG SW ON	Air conditioning ON	8 - 14
ACIS - E1	Idling		2.0 or less
	5,100 rpm or more		10 - 14
T - E1	IG SW ON	Check connector TE1 - E1 not connect	10 - 14
		Check connector TE1 - E1 connect	1 or less
NSW - E1	IG SW ON	Shift position P or N range	0 - 2
		Ex. shift position P or N range	6 - 14

Engine (and ECT) ECU Terminals

\*1 w/o ECT \*2 w/ ECT

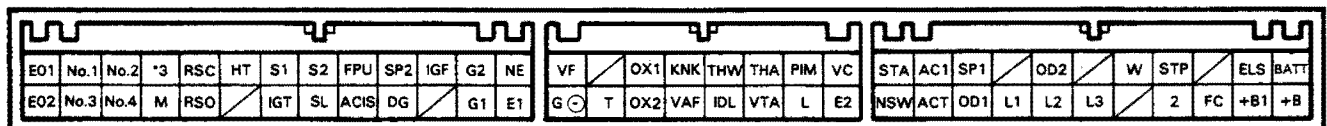

\*3 w/ TWC → STJ  
 w/o ECT → P

### Voltage at Engine ECU Wiring Connectors (3S-GTE)

Terminals	Condition		STD voltage (V)
+B +B1 - E1	IG SW ON		10 - 14
BATT - E1	-		10 - 14
IDL - E2	IG SW ON	Throttle valve open	4 - 6
VTA - E2		Throttle valve fully closed	0.1 - 1.0
		Throttle valve open	4 - 5
VC - E2		-	4 - 6
VS - E2		Measuring plate fully closed	3.7 - 4.3
		Measuring plate fully open	0.2 - 0.5
	Idling	2.3 - 3.8	
		3,000 rpm	1.0 - 2.0
No.1 No.2 - E01 No.3 - E02 No.4	IG SW ON		10 - 14
THA1 - E2	IG SW ON	Intake air temp. 20°C (68°F)	1 - 3
THW - E2	IG SW ON	Coolant temp. 80°C (176°F)	0.1 - 1.0
STA - E1	Cranking		6 - 14
IGT - E1	Idling		0.7 - 1.0
RSC RSO - E1	IG SW ON	Engine ECU connectors disconnected	8 - 14
W - E1	No trouble ("CHECK" engine warning light off) and engine running		10 - 14
AC1 - E1	IG SW ON	Air conditioning ON	8 - 14
PIM - E2	IG SW ON		2.5 - 4.5
*1 T-VIS - E1	IG SW ON	Throttle valve fully closed	2.0 or less
		Throttle valve open	10 - 14
*2 T-VIS - E1	Idling		10 - 14
	4,200 rpm or more		2.0 or less
T - E1	IG SW ON	Check connector TE1 - E1 not connect	10 - 14
		Check connector TE1 - E1 connect	1 or less

**Engine ECU Terminals**

\*1 w/ Regular Unleaded Gasoline  
 \*2 w/ Premium Unleaded Gasoline

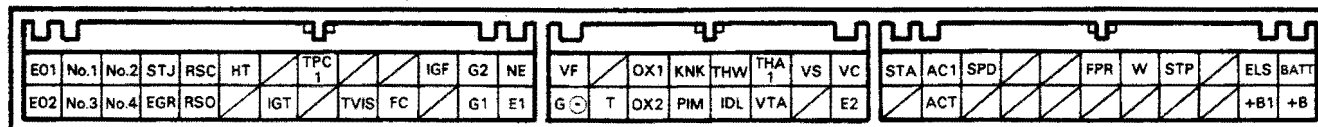

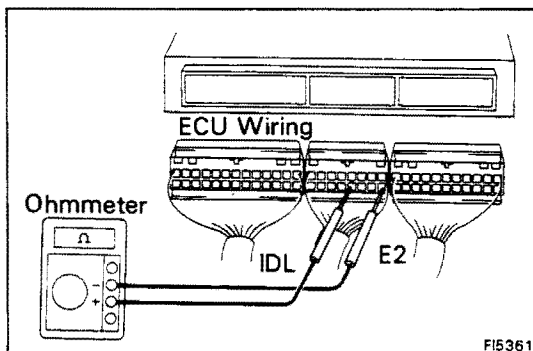
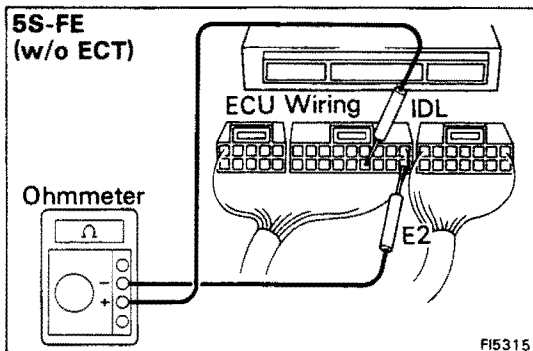

**2. INSPECT RESISTANCE OF ENGINE ECU**

**NOTICE:**

- Do not touch the engine ECU terminals.
- The tester probe should be inserted into the wiring connector from the wiring side.

Check the resistance between each terminal of the wiring connectors.

- Disconnect the connectors from the engine ECU.
- Measure the resistance at each terminal.

**Resistance of Engine ECU Wiring Connectors (5S-FE w/o ECT)**

Terminals	Condition	Resistance ( $\Omega$ )
IDL - E1	Throttle valve open	Infinity
	Throttle valve fully closed (Throttle opener must be cancelled first)	0
PSW - E1	Throttle valve fully open	0
	Throttle valve fully closed (Throttle opener must be cancelled first)	Infinity
THA - E2	Intake air temp. 20°C (68°F)	2,000 - 3,000
THW - E2	Coolant temp. 80°C (176°F)	200 - 400
G1 NE - G⊖	-	170 - 210
ISCC - +B ISCO - +B1	-	19.3 - 22.3

**Engine ECU Terminals**

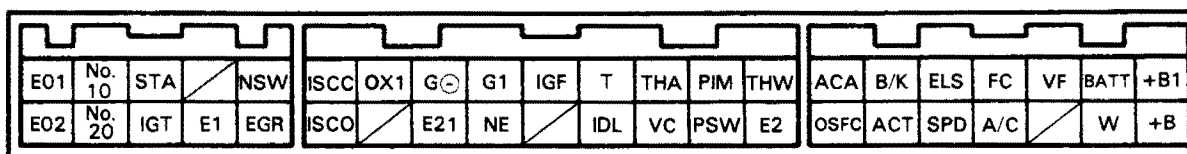

### Resistance of Engine ECU Wiring Connectors (5S-FE w/ ECT)

Terminals	Condition	Resistance (Ω)
IDL - E2	Throttle valve open	Infinity
	Throttle valve fully closed (Throttle opener must be cancelled first)	2,300 or less
VTA - E2	Throttle valve fully open	3,500 - 10,000
	Throttle valve fully closed (Throttle opener must be cancelled first)	200 - 800
VC - E2	-	3,000 - 7,000
THA - E2	Intake air temp. 20°C (68°F)	2,000 - 3,000
THW - E2	Coolant temp. 80°C (176°F)	200 - 400
G1 NE - G⊖	-	170 - 210
ISCC +B ISCO - +B1	-	19.3 - 22.3

**Engine and ECT ECU Terminals**

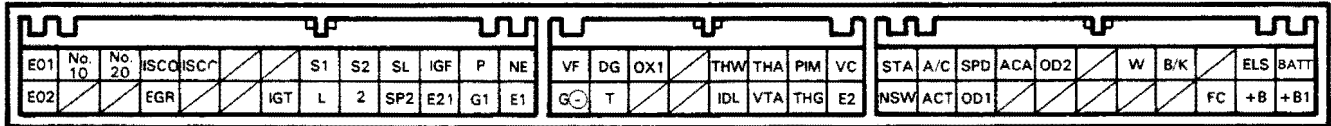

FI2796

### Resistance of Engine ECU Wiring Connectors (3S-GE)

Terminals	Condition	Resistance (Ω)
IDL - E2	Throttle valve open	Infinity
	Throttle valve fully closed	2,300 or less
VTA - E2	Throttle valve fully open	3,500 - 10,000
	Throttle valve fully closed	200 - 800
VC - E2	-	3,000 - 7,000
THA - E2	Intake air temp. 20°C (68°F)	2,000 - 3,000
THW - E2	Coolant temp. 80°C (176°F)	200 - 400
G1 G2 - G⊖	-	140 - 180
NE - G⊖	-	180 - 220
RSC +B RSO - +B1	-	19.3 - 22.3

**Engine (and ECT ECU) Terminals**

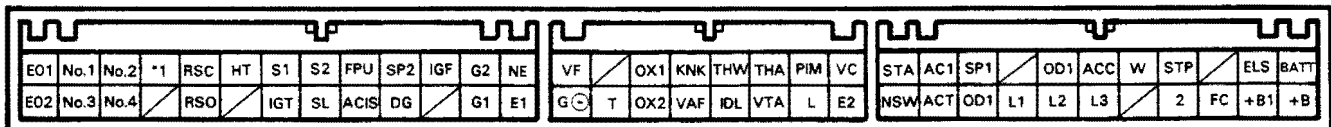

\*1 w/ TWC → STJ  
w/o ECT → P

FI2796

### Resistance of Engine ECU Wiring Connectors (3S-GTE)

Terminals	Condition	Resistance ( $\Omega$ )
IDL - E2	Throttle valve open	Infinity
	Throttle valve fully closed	2,300 or less
VTA - E2	Throttle valve fully open	3,500 - 10,000
	Throttle valve fully closed	200 - 800
VC - E2	-	200 - 400
VS - E2	Measuring plate fully closed	200 - 600
	Measuring plate fully open	20 - 1,200
THA1 - E2	Intake air temp. 20°C (68°F)	2,000 - 3,000
THW - E2	Coolant temp. 80°C (176°F)	200 - 400
G1 G2 - G $\ominus$	-	140 - 180
NE - G $\ominus$	-	180 - 220
RSC +B RSO +B1	-	19.3 - 22.3

Engine ECU Terminals

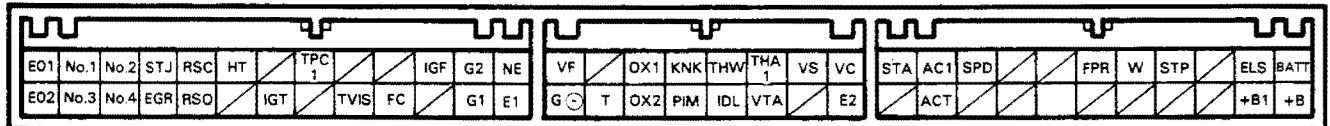



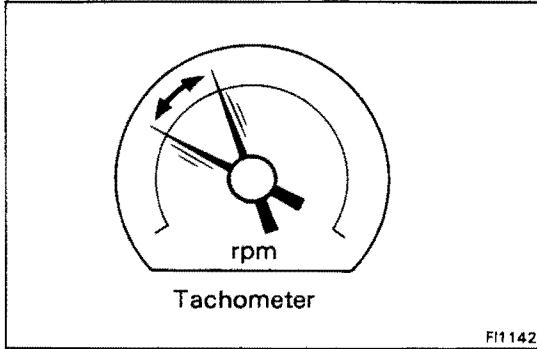
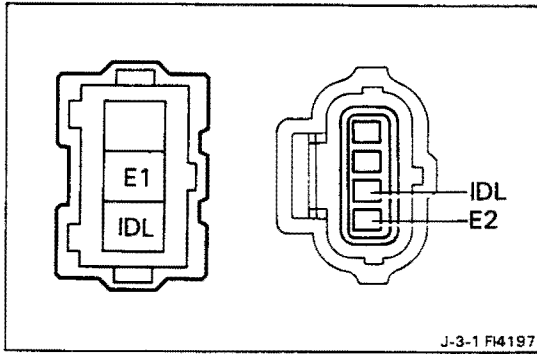

## Fuel Cut RPM

### INSPECTION OF FUEL CUT RPM

#### 1. WARM UP ENGINE

Allow the engine to reach normal operating temperature.

#### 2. INSPECT FUEL CUT RPM

- (a) Disconnect the connector from the throttle position sensor.
- (b) Connect terminals IDL and E1 (5S-FE w/o ECT) or E2 (others) of the wiring connector.
- (c) Gradually raise the engine rpm and check that there is fluctuation between the fuel cut and fuel return points.

#### HINT:

- The vehicle should be stopped.
- Accessories switched OFF.

<b>Fuel cut rpm:</b>	<b>5S-FE</b>	<b>1,700 rpm</b>
	<b>3S-GE</b>	<b>2,000 rpm</b>
	<b>3S-GTE</b>	<b>2,000 rpm</b>
<b>Fuel return rpm:</b>	<b>5S-FE</b>	<b>1,100 rpm</b>
	<b>3S-GE</b>	<b>1,700 rpm</b>
	<b>3S-GTE</b>	<b>1,600 rpm</b>

## Fuel Pressure Control System (3S-GE only)

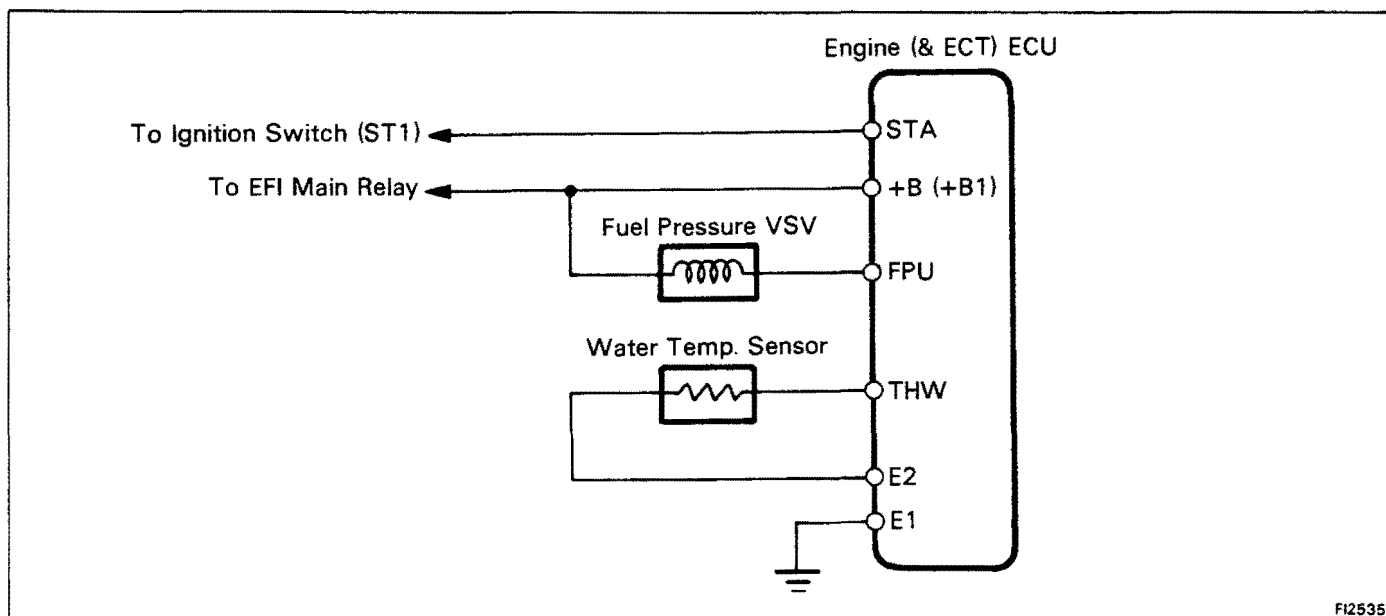

FI2535

### INSPECTION OF FUEL PRESSURE CONTROL SYSTEM

1. INSPECT WATER TEMPERATURE SENSOR  
 (See page FI-186)

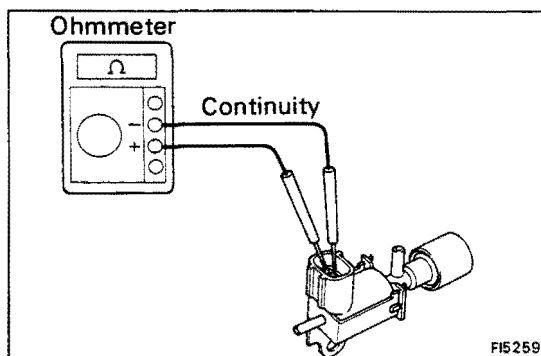

FI5259

2. INSPECT FUEL PRESSURE VSV

#### A. Inspect VSV for open circuit

Using an ohmmeter, check that there is continuity between the terminals.

Resistance (Cold):  $33 - 39 \Omega$

If there is no continuity, replace the VSV.

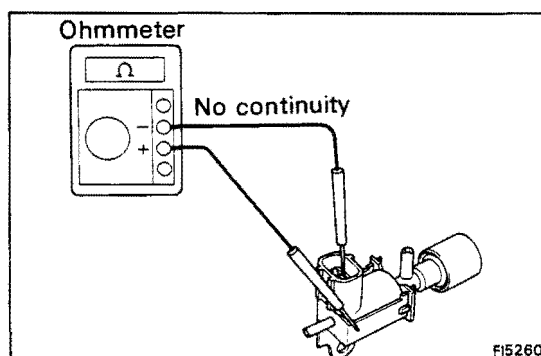

FI5260

#### B. Inspect VSV for ground

Using an ohmmeter, check that there is no continuity between each terminal and the body.

If there is continuity, replace the VSV.

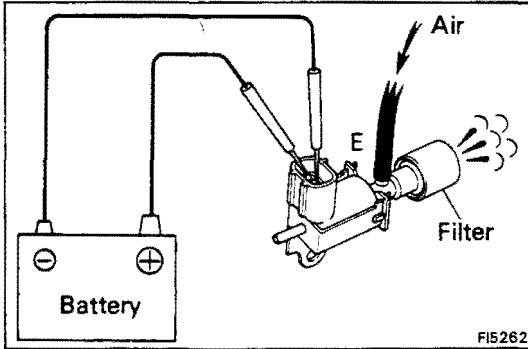
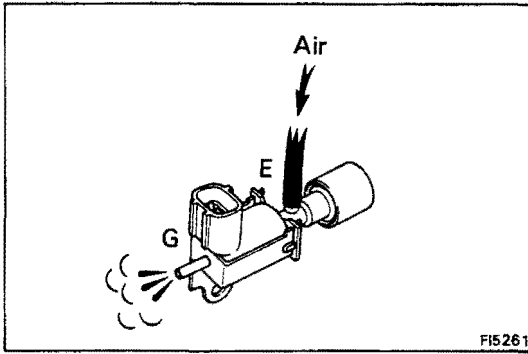
**C. Inspect VSV operation**

(a) Check that air flows from pipes E to G.

(b) Apply battery voltage across the terminals.

(c) Check that air flows from pipe E to the filter.

If operation is not as specified, replace the VSV.

---

# COOLING SYSTEM

	<b>Page</b>
<b>DESCRIPTION</b> .....	<b>CO-2</b>
<b>TROUBLESHOOTING</b> .....	<b>CO-5</b>
<b>CHECK AND REPLACEMENT OF ENGINE</b>	
<b>COOLANT</b> .....	<b>CO-6</b>
<b>WATER PUMP</b> .....	<b>CO-7</b>
<b>THERMOSTAT</b> .....	<b>CO-12</b>
<b>RADIATOR</b> .....	<b>CO-14</b>
<b>ELECTRIC COOLING FAN</b> .....	<b>CO-15</b>

# DESCRIPTION

This engine utilizes a pressurized water circulation cooling system which includes a thermostat equipped with a by-pass valve mounted on the inlet side.

## 5S-FE

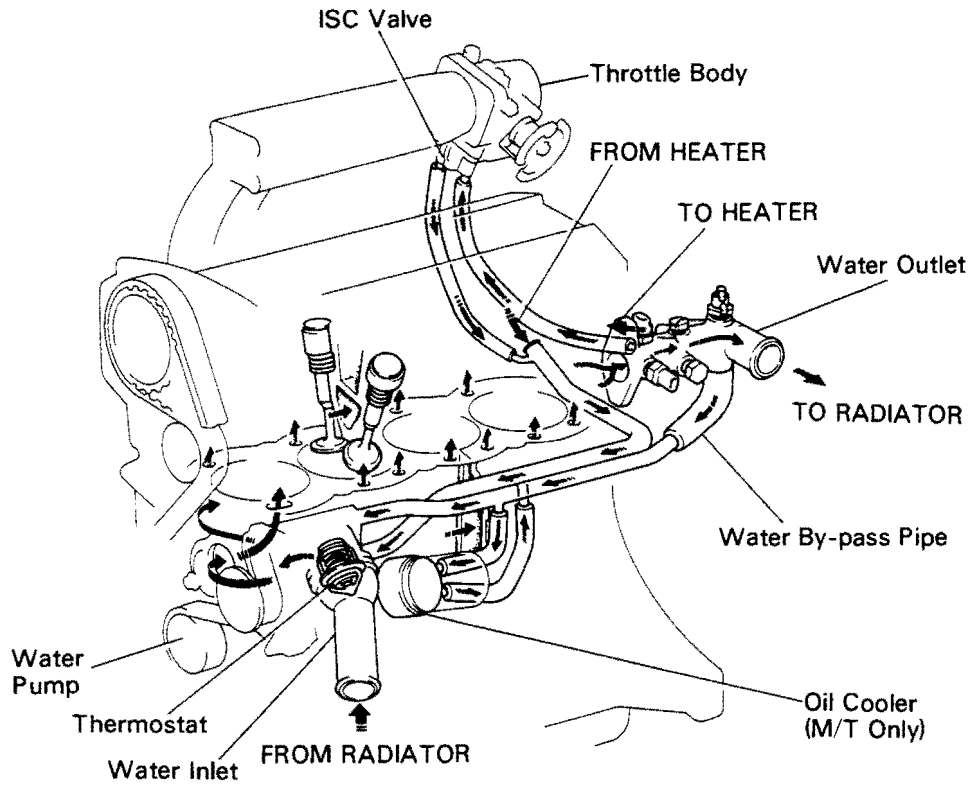

## 3S-GE

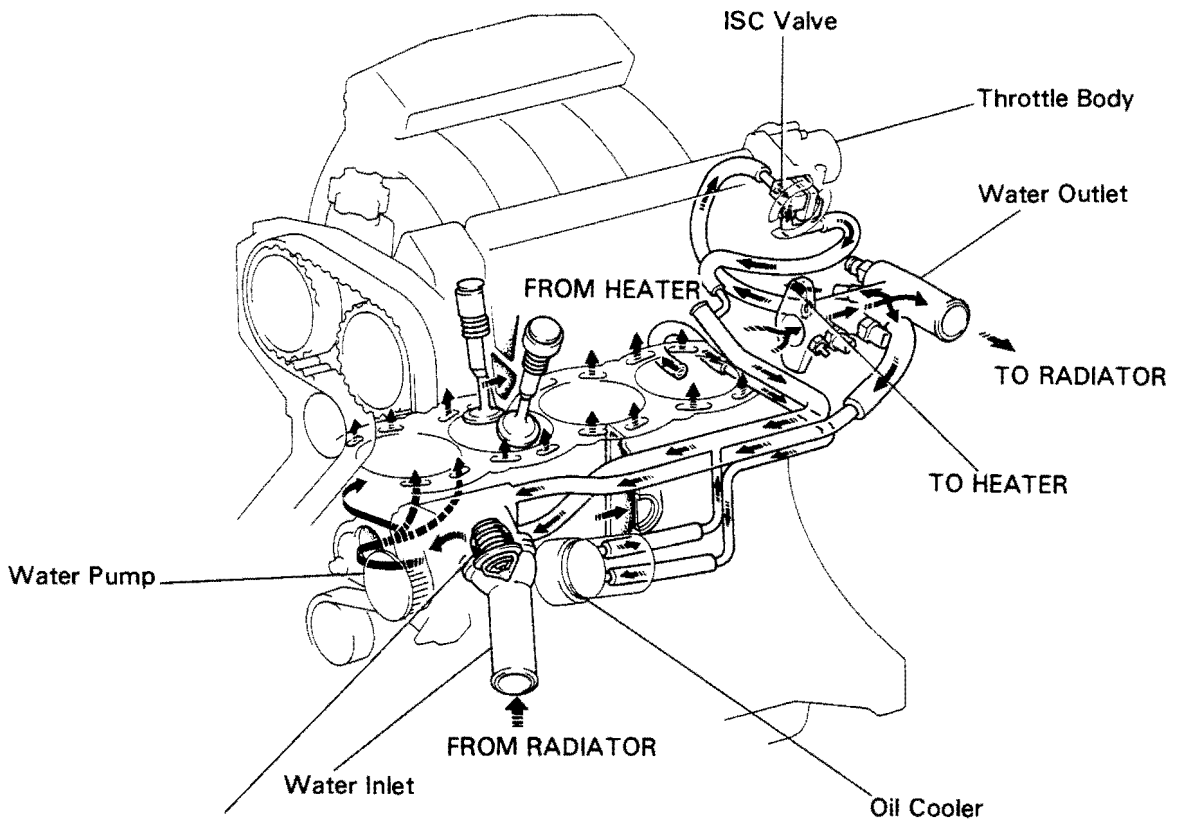

3S-GTE

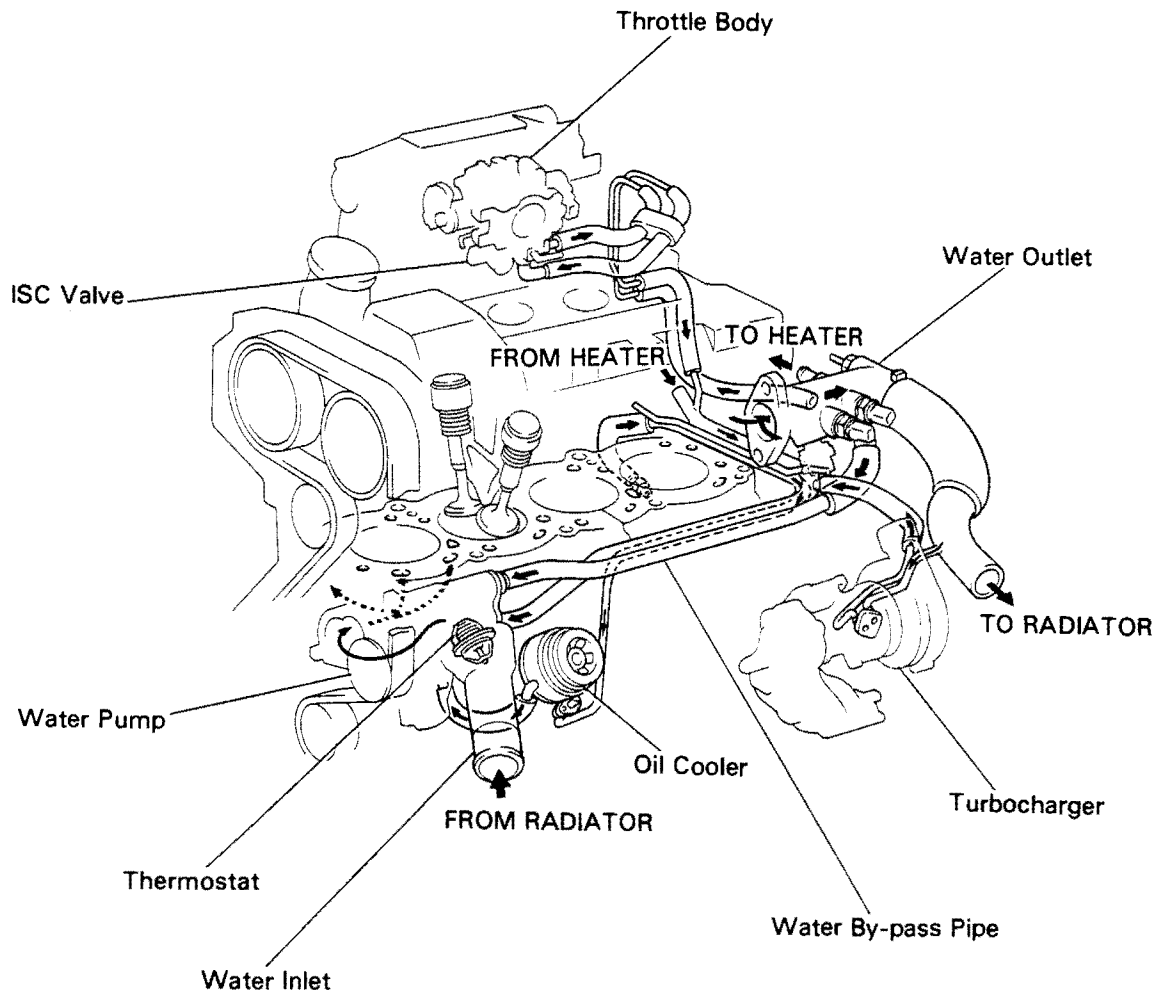

The cooling system is composed of the water jacket (inside the cylinder block and cylinder head), radiator, water pump thermostat, electric fan, hoses and other components.

Coolant which is heated in the water jacket is pumped to the radiator through which an electric fan blows air to cool the coolant as it passes through. Coolant which has been cooled is then sent back to the engine by the water pump, where it cools the engine.

The water jacket is a network of channels in the shell of the cylinder block and cylinder head through which coolant passes. It is designed to provide adequate cooling of the cylinders and combustion chambers which become hot during engine operation.

### **RADIATOR**

The radiator performs the function of cooling the coolant which has passed through the water jacket and become hot, and it is mounted in the front of the vehicle. The radiator consists of an upper tank and lower tank, and a core which connects the two tanks. The upper tank contains coolant from the water jacket and the filler inlet. It also has a hose attached through which excess coolant can flow. The lower tank has an outlet and drain cock for the coolant. The core contains many tubes through which coolant flows from the upper tank to the lower tank as well as cooling fins which radiator heat away from the coolant in the tubes. The air sucked through the radiator by the electric fan, as well as the wind generated by the vehicle's travel, passes through the radiator, cooling the coolant. Models with automatic transmission include an automatic transmission fluid cooler built into the lower tank of the radiator. A fan with an electric motor is mounted behind the radiator to assist the flow of air through the radiator. The fan operates when the coolant temperature becomes high in order to prevent it from becoming too high.

### **RADIATOR CAP**

The radiator cap is a pressure type cap which seals the radiator, resulting in pressurization of the radiator as the coolant expands. The pressurization prevents the coolant from boiling even when the coolant temperature exceeds 100°C (212°F). A relief valve (pressurization valve) and a vacuum valve (negative pressure valve) are built into the radiator cap. The relief valve opens and lets steam escape through the overflow pipe when the pressure generated inside the cooling system exceeds the limit (coolant temperature: 110 – 120°C, 230 – 248°F, pressure: 0.3 – 1.0 kg/cm<sup>2</sup>, 4.3-14.2 psi, 29.4-98.1 kPa). The vacuum valve opens to alleviate the vacuum which develops in the coolant system after the engine is stopped and the coolant temperature drops. The valve's opening allows the coolant in the reservoir tank to return to the cooling system.

### **RESERVOIR TANK**

The reservoir tank is used to catch coolant which overflows the cooling system as a result of volumetric expansion when the coolant is heated. The coolant in the reservoir tank returns to the radiator when the coolant temperature drops, thus keeping the radiator full at all times and avoiding needless coolant loss. Check the reservoir tank level to learn if the coolant needs to be replenished.

### **WATER PUMP**

The water pump is used for forced circulation of coolant through the cooling system. It is mounted on the front of the cylinder block and driven by a timing belt.

### **THERMOSTAT**

The thermostat has a wax type by-pass valve and is mounted in the water inlet housing. The thermostat includes a type of automatic valve operated by fluctuations in the temperature. This valve closes when the coolant temperature drops, preventing the circulation of coolant through the engine and thus permitting the engine to warm up rapidly. The valve opens when the coolant temperature has risen, allowing the circulation of coolant. Wax inside the thermostat expands when heated and contracts when cooled. Heating the wax thus generates pressure which overpowers the force of the spring which keeps the valve closed, thus opening the valve. When the wax cools, its contraction causes the force of the spring to take effect once more, closing the valve. The thermostat in this engine operates at a temperature of 82°C (180°F).

## TROUBLESHOOTING

Problem	Possible cause	Remedy	Page
Engine overheats	Dirt, leaves or insects in radiator or condenser	Clean radiator or condenser	CO-14
	Hoses, water pump, thermostat housing, radiator, heater, core plugs or head gasket leakage	Repair as necessary	
	Thermostat faulty	Check thermostat	CO-12
	Incorrect ignition timing	Reset timing	EM-22, 23
	Electric cooling system faulty	Inspect electric cooling system	CO-15
	Radiator hose plugged or rotted	Replace hose	
	Water pump faulty	Replace water pump	CO-7
	Radiator plugged or cap faulty	Check radiator and cap	CO-14
	Cylinder head or block cracked or water passage clogged	Repair as necessary	

**HINT:** If the engine tends to overheat, removal of the thermostat will adversely effect cooling efficiency.



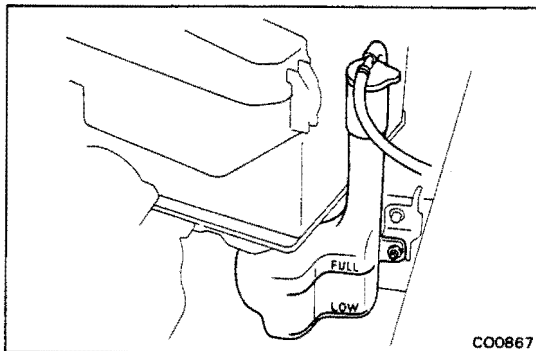

CO0867

## CHECK AND REPLACEMENT OF ENGINE COOLANT

### 1. CHECK ENGINE COOLANT LEVEL AT RESERVE TANK

The coolant level should be between the "LOW" and "FULL" lines.

If low, check for leaks and add coolant up to the "FULL" line.

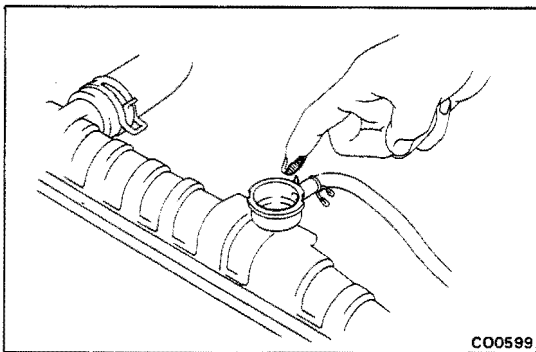

CO0599

### 2. CHECK ENGINE COOLANT QUALITY

There should not be any excessive deposits of rust or scales around the radiator cap or radiator filler, hole, and the coolant should be free from oil.

If excessively dirty, replace the coolant.

### 3. REPLACE ENGINE COOLANT

(a) Remove the radiator cap.

**CAUTION:** To avoid the danger of being burned, do not remove the cap while the engine and radiator are still hot, as fluid and steam can be blown out under pressure.

(b) Drain the coolant from the radiator and rear left of engine block.

(c) Close the drain cocks.

**Torque (Engine drain cock):** 130 kg-cm  
(9 ft-lb, 13 N-m)

(d) Slowly fill the system with coolant.

Use a good brand of ethylene-glycol or TOYOTA radiator conditioner or equivalent anticorrosive, mixed according to the maker's directions.

Ethylene-glycol type: This type has an antifreeze and anticorrosive effect.

TOYOTA radiator conditioner: This has only an anti-corrosive effect.

#### NOTICE:

- Do not use an alcohol type coolant.
- The coolant should be mixed with demineralized water or distilled water.

**Capacity (w/ Heater):**

#### 5S-FE

M/T 6.5 liters (6.8 US qts, 5.7 Imp. qts)

A/T 6.6 liters (7.0 US qts, 5.8 Imp. qts)

#### 3S-GE, 3S-GTE

M/T 6.0 liters (6.3 US qts, 5.3 Imp. qts)

A/T 6.5 liters (6.9 US qts, 5.7 Imp. qts)

(e) Reinstall the radiator cap.

(f) Warm up the engine and check for leaks.

(g) Recheck the coolant level and refill as necessary.

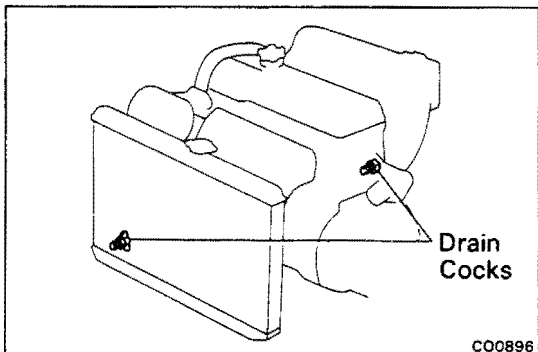

CO0896

## WATER PUMP COMPONENTS

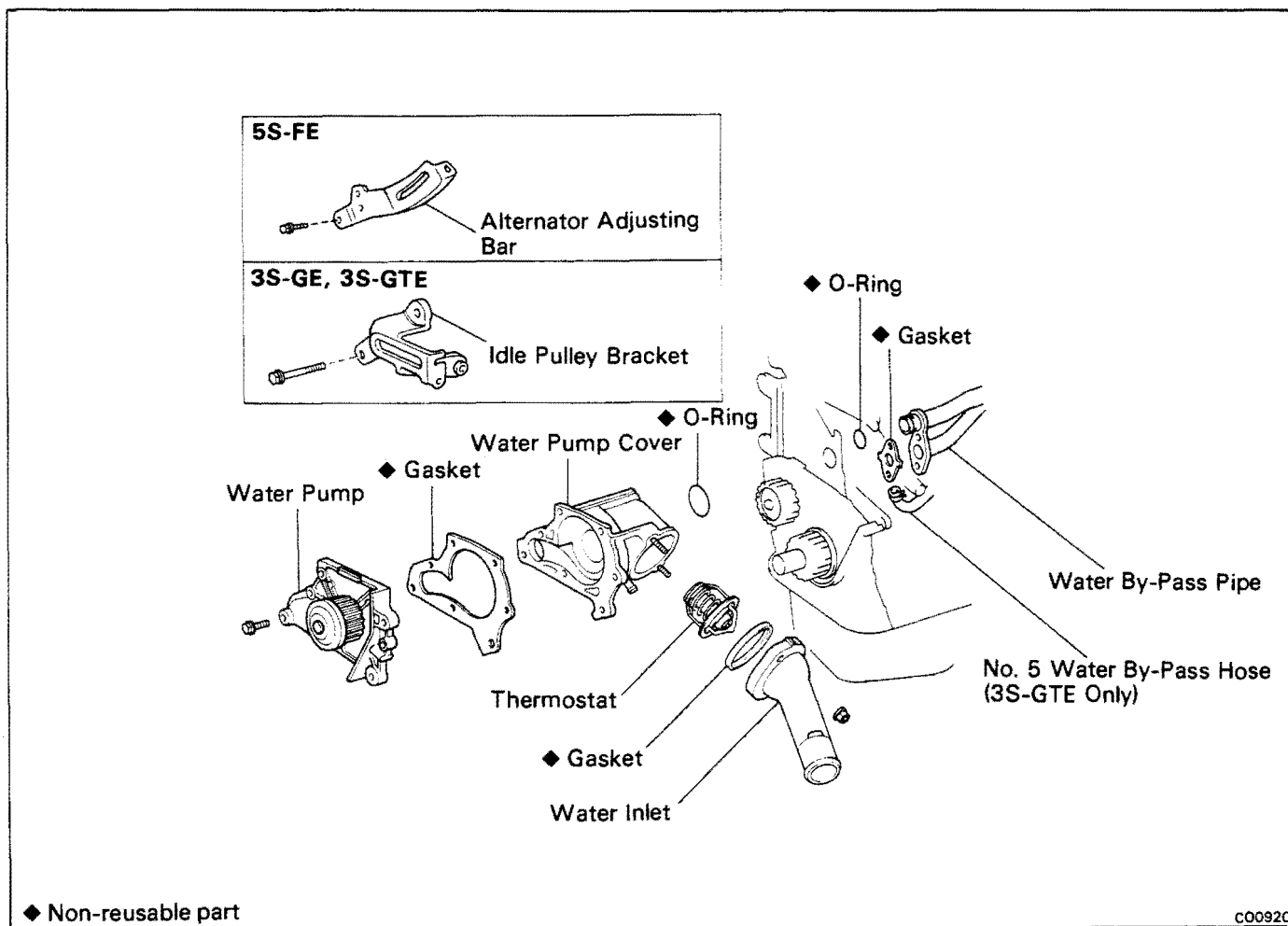

### REMOVAL OF WATER PUMP

1. DRAIN ENGINE COOLANT (See page CO-6)
2. REMOVE TIMING BELT  
(5S-FE: See steps 1 to 12 on pages EM-33 to 37)  
(3S-GE, 3S-GTE: See steps 1 to 17 on pages EM-45 to 49)
3. REMOVE IDLER PULLEYS  
(5S-FE: See steps 13, 14 on page EM-37)  
(3S-GE, 3S-GTE: See steps 18, 19 on page EM-50)

5S-FE

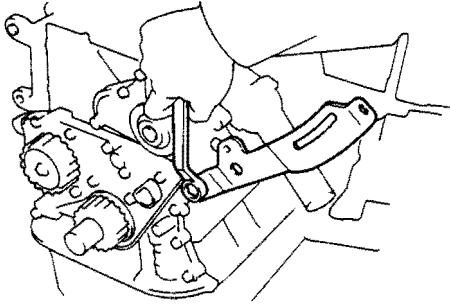

3S-GE, 3S-GTE

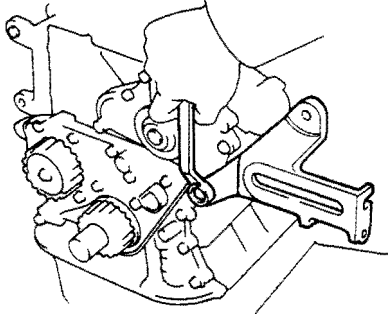
CO0874  
CO0904

**4. (5S-FE)  
REMOVE ALTERNATOR BELT ADJUSTING BAR**

Remove the bolt and adjusting bar.

**(3S-FE, 3S-GTE)  
REMOVE IDLER PULLEY BRACKET**

Remove the bolt and pulley bracket.

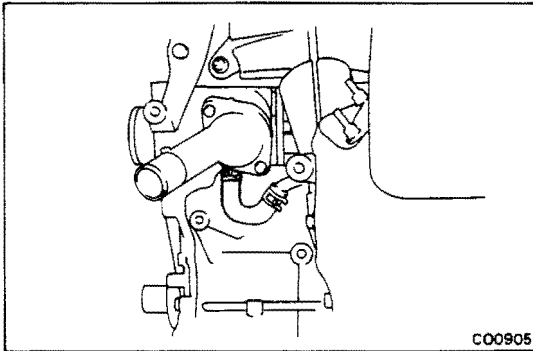

CO0905

**5. (3S-GTE)  
DISCONNECT OIL COOLER WATER BY-PASS HOSE**

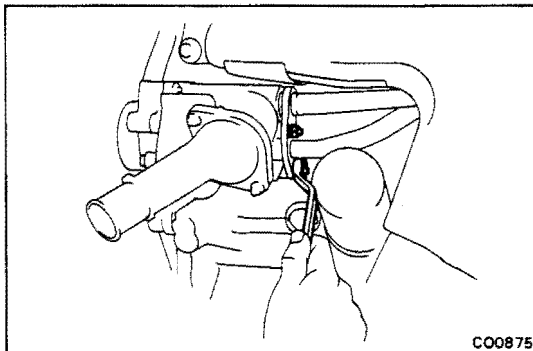

CO0875

**6. REMOVE WATER PUMP AND WATER PUMP COVER ASSEMBLY**

(a) Remove the two nuts holding the pump to the water by-pass pipe.

(b) Remove the three bolts in the sequence shown.

(c) Pull out the water pump together with the water pump cover.

(d) Remove the gasket and two O-rings from the water pump and water by-pass pipe.

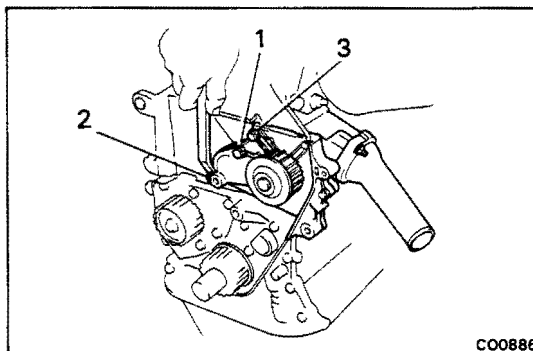

CO0886

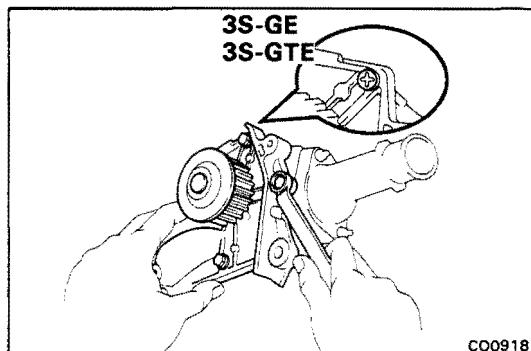

### 7. SEPARATE WATER PUMP AND WATER PUMP COVER

Remove the three bolts, water pump gasket from the water pump cover.

### 8. REMOVE WATER INLET AND THERMOSTAT FROM WATER PUMP COVER (See step 4 on page CO-12)

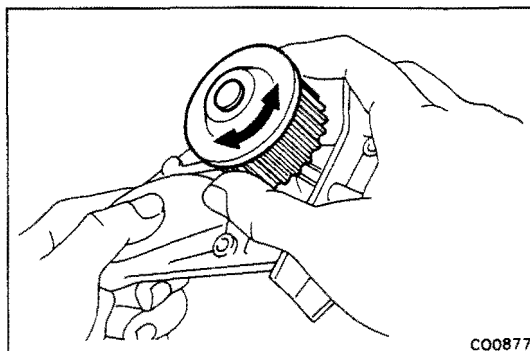

## INSPECTION OF WATER PUMP

### INSPECT WATER PUMP

Turn the pulley and check that the water pump bearing moves smoothly and quietly.

## INSTALLATION OF WATER PUMP

(See page CO-7)

### 1. INSTALL THERMOSTAT AND WATER INLET TO WATER PUMP COVER

(See steps 1 and 2 on page CO-13)

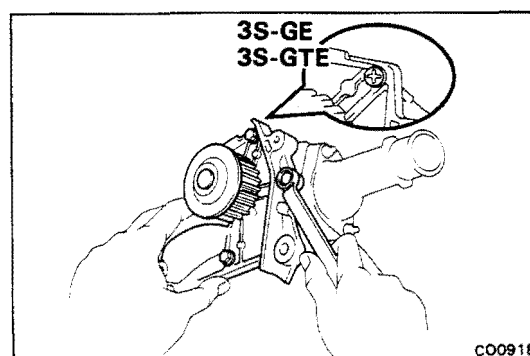

### 2. ASSEMBLE WATER PUMP AND WATER PUMP COVER

Install a new gasket and the water pump to the pump cover with the three bolts.

**Torque: 95 kg-cm (82 in.-lb, 9.3 N-m)**

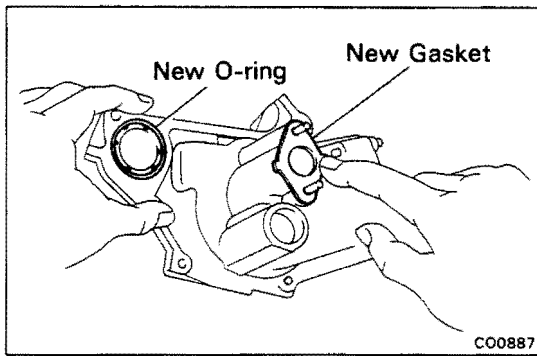

### 3. INSTALL WATER PUMP AND WATER PUMP COVER ASSEMBLY

(a) Install new O-ring and gasket to the water pump cover.

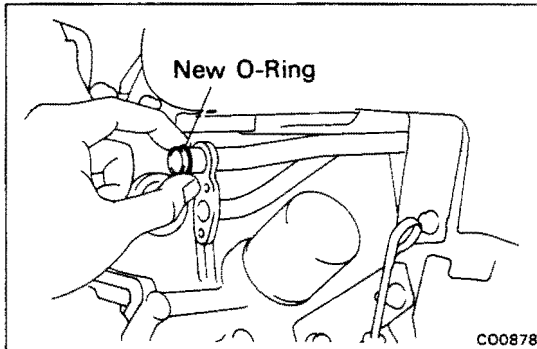

(b) Install a new O-ring to the water by-pass pipe.

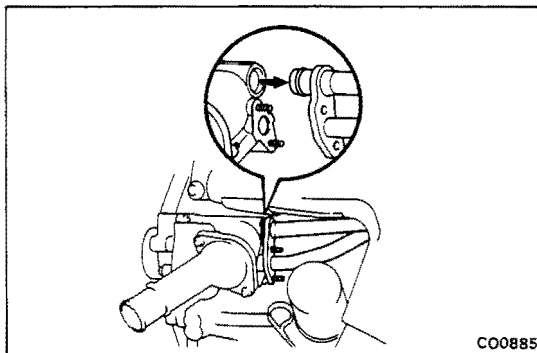

(c) Apply soapy water to the O-ring the water by-pass pipe.

(d) Connect the pump cover to the water by-pass pipe. Do not install nuts yet.

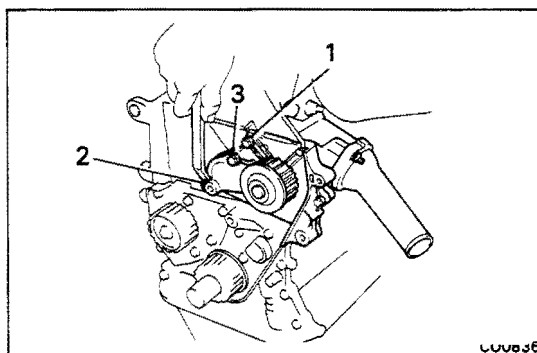

(e) Install the water pump with the three bolts. Tighten the bolts in the sequence shown.

**Torque: 95 kg-cm (82 in.-lb, 9.3 N-m)**

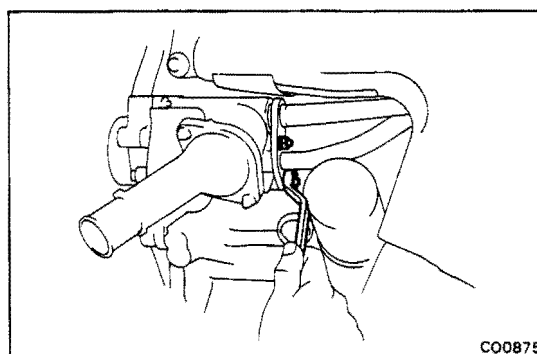

(f) Install the two nuts holding the water pump cover to the water by-pass pipe.

**Torque: 95 kg-cm (82 in.-lb, 9.3 N-m)**

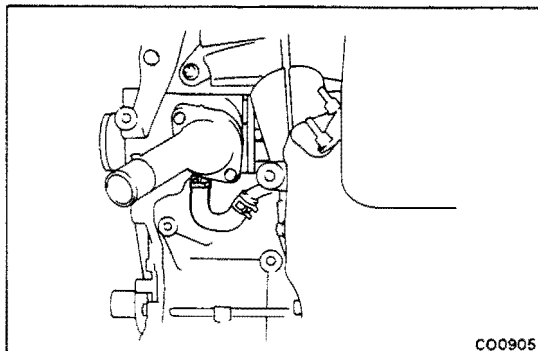

3. **(3S-GTE)**  
**CONNECT OIL COOLER WATER BY-PASS HOSE**

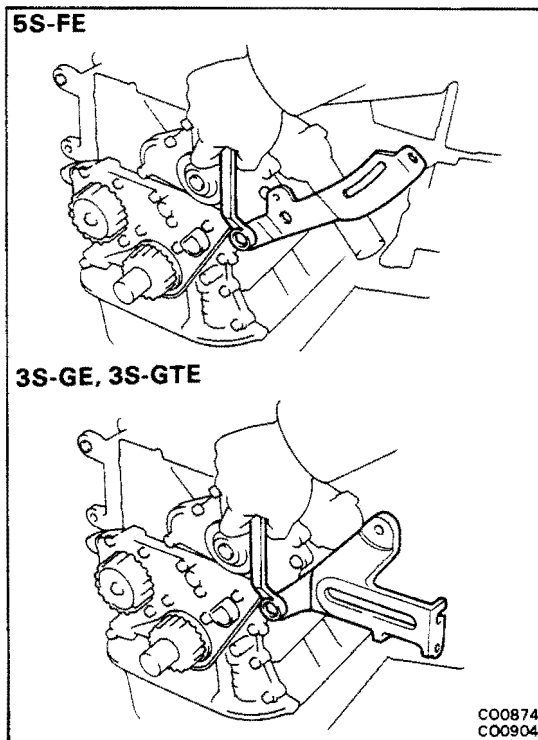

4. **(5S-FE)**  
**INSTALL ALTERNATOR BELT ADJUSTING BAR**  
Temporarily install the adjusting bar with the bolt.

- (3S-GE, 3S-GTE)**  
**INSTALL IDLER PULLEY BRACKET**  
Temporarily install pulley bracket with the bolt.

6. **INSTALL IDLER PULLEYS**  
(5S-FE: See steps 3, 4 on page EM-40)  
(3S-GE, 3S-GTE: See steps 2, 3 on page EM-53)
7. **INSTALL TIMING BELT**  
(5S-FE: See steps 5 to 17 on pages EM-40 to 44)  
(3S-GE, 3S-GTE: See steps 4 to 24 on pages EM-53 to 58)
8. **FILL WITH ENGINE COOLANT (See page CO-6)**

# THERMOSTAT

## REMOVAL OF THERMOSTAT

1. DRAIN ENGINE COOLANT (See page CO-6)
2. (3S-GTE)  
REMOVE ALTERNATOR AIR DUCTS

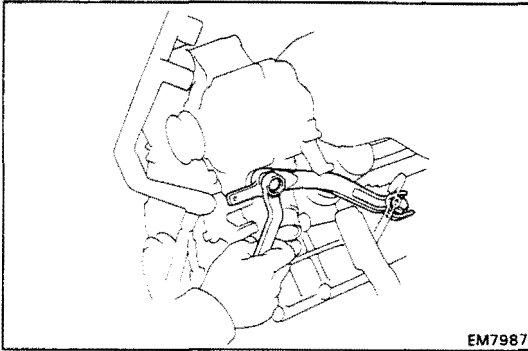

3. (3S-GE, 3S-GTE)  
REMOVE ALTERNATOR BRACKET

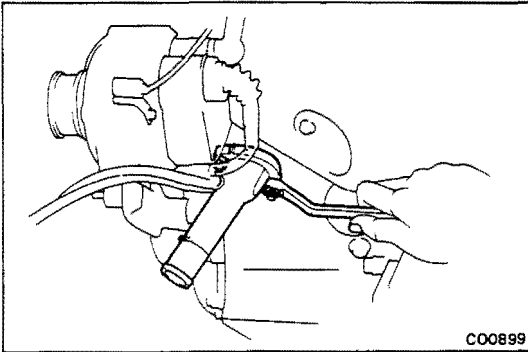

4. REMOVE WATER INLET AND THERMOSTAT

- (a) Remove the two nuts and water inlet from the water pump.
- (b) Remove the thermostat.
- (c) Remove the gasket from the thermostat.

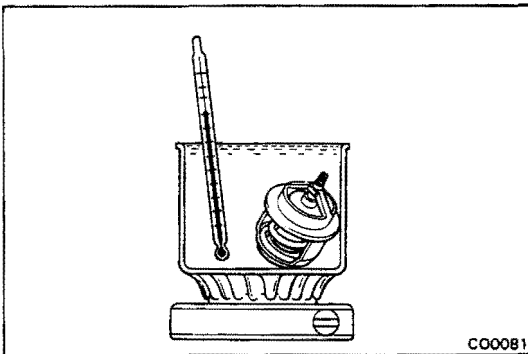

## INSPECTION OF THERMOSTAT

### INSPECT THERMOSTAT

**HINT:** The thermostat is numbered with the valve opening temperature.

- (a) Immerse the thermostat in water and gradually heat the water.
- (b) Check the valve opening temperature.

**Valve opening temperature: 80 – 84°C  
(176 – 183°F)**

If the valve opening temperature is not as specified, replace the thermostat.

- (c) Check the valve lift.

**Valve lift: 8 mm (0.31 in.) or more at 95°C (203°F)**

If the valve lift is less than specification, replace the thermostat.

- (d) Check that the valve spring is tight when the thermostat is fully closed.

If necessary, replace the thermostat.

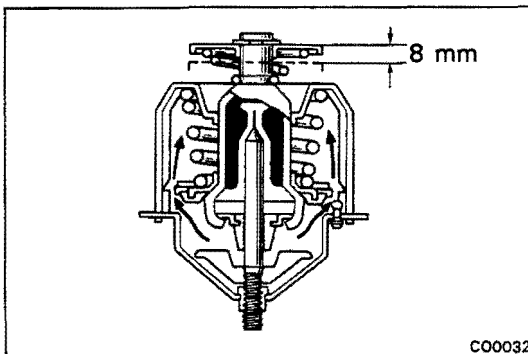

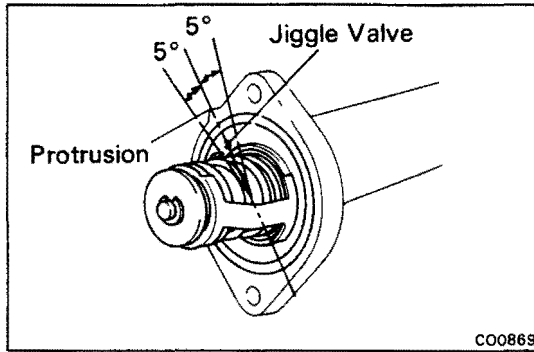

## INSTALLATION OF THERMOSTAT

### 1. PLACE THERMOSTAT IN WATER INLET

- (a) Install a new gasket to the thermostat.
- (b) Align the jiggle valve of the thermostat with the protrusion, and insert the thermostat in the water inlet.

**HINT:** The jiggle valve may be set within 10° of either side of the prescribed position.

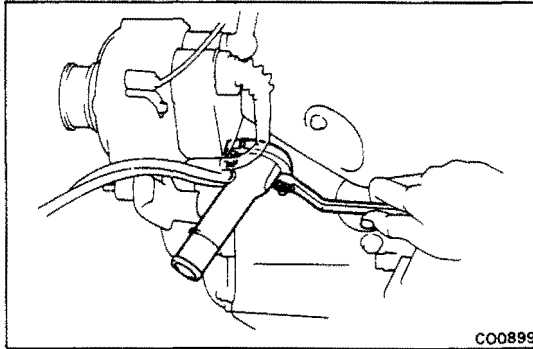

### 2. INSTALL WATER INLET

Install the water inlet with the two nuts.

**Torque:** 90 kg-cm (78 in.-lb, 8.8 N-m)

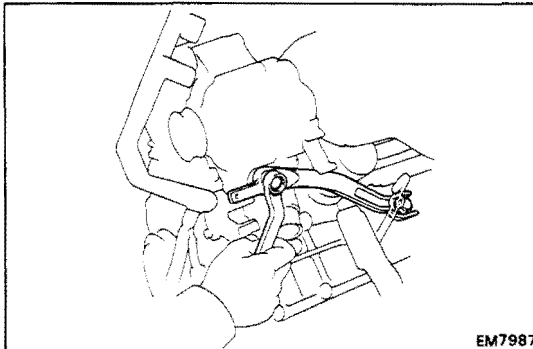

### 3. (3S-GE, 3S-GTE)

**INSTALL ALTERNATOR BRACKET**

### 4. (3S-GTE)

**INSTALL ALTERNATOR AIR DUCTS**

### 5. FILL WITH ENGINE COOLANT (See page CO-6)

### 6. START ENGINE AND CHECK FOR LEAKS



# RADIATOR

## CLEANING OF RADIATOR

Using water or a steam cleaner, remove any mud and dirt from the radiator core.

**NOTICE:** If using a high pressure type cleaner, be careful not to deform the fins of the radiator core. If the cleaner nozzle pressure is 30 – 35 kg/cm<sup>2</sup> (427 – 498 psi, 2,942 – 3,432), keep a distance of at least 40 – 50 cm (15.75 – 19.69 in.) between the radiator core and cleaner nozzle.

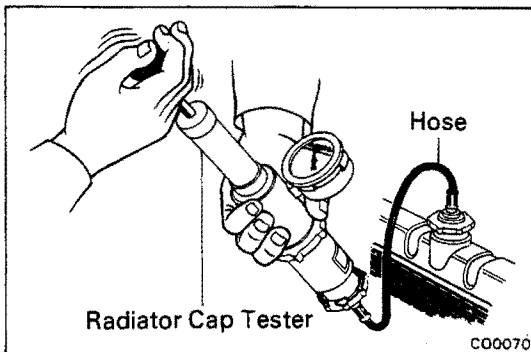
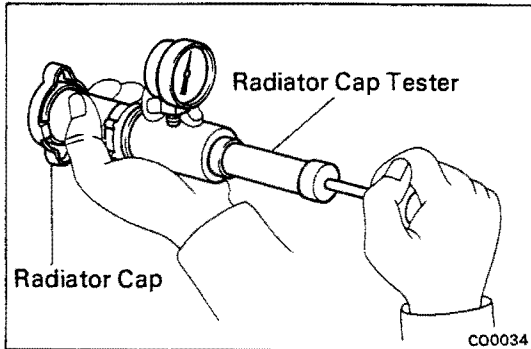

## INSPECTION OF RADIATOR

### 1. INSPECT RADIATOR CAP

Using a radiator cap tester, pump the tester and measure the relief valve opening pressure.

**Standard opening pressure:**

0.75 – 1.05 kg/cm<sup>2</sup>

(10.7 – 14.9 psi, 74 – 103 kPa)

**Minimum opening pressure:** 0.6 kg/cm<sup>2</sup>

(8.5 psi, 59 kPa)

If the opening pressure is less than minimum replace the radiator cap.

### 2. INSPECT COOLING SYSTEM FOR LEAKS

- (a) Fill the radiator with coolant and attach a radiator cap tester.
- (b) Warm up the engine.
- (c) Pump it to 1.2 kg/cm<sup>2</sup> (17.1 psi, 118 kPa), check that pressure does not drop.

If the pressure drops, check for leaks in the hoses, radiator or water pump. If no external leaks are found, check the heater core, cylinder block and head.

# ELECTRIC COOLING FANS SYSTEM CIRCUIT

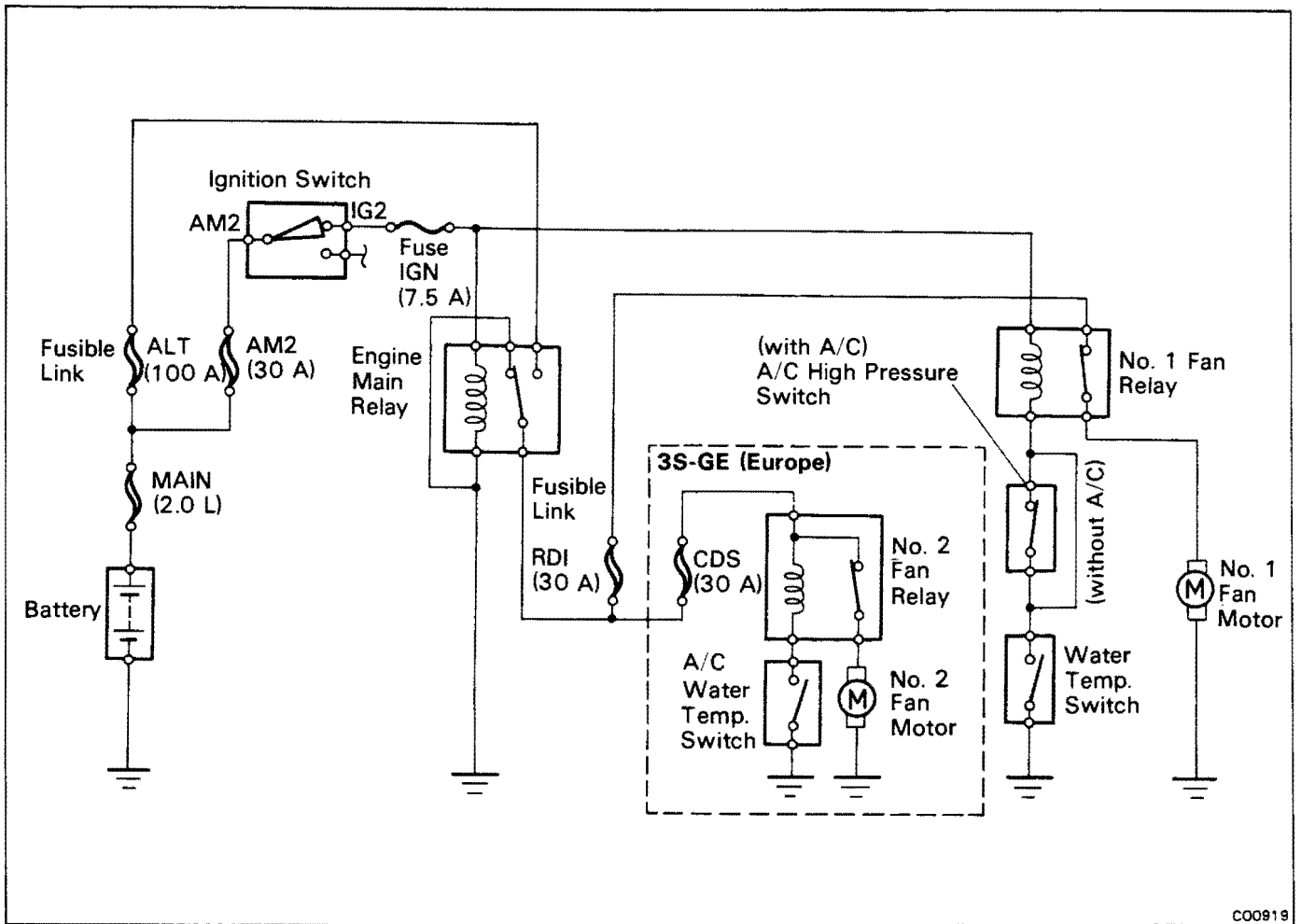

CO0919

## COMPONENTS

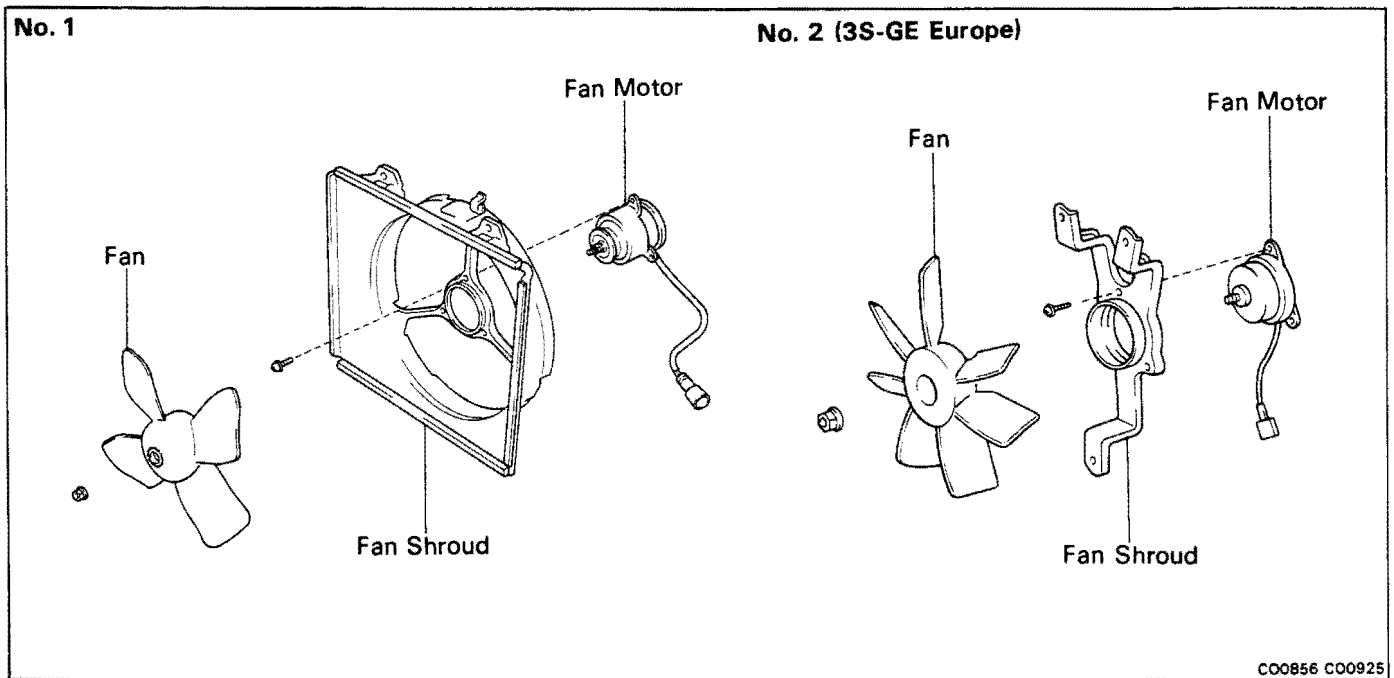

CO0856 CO0925

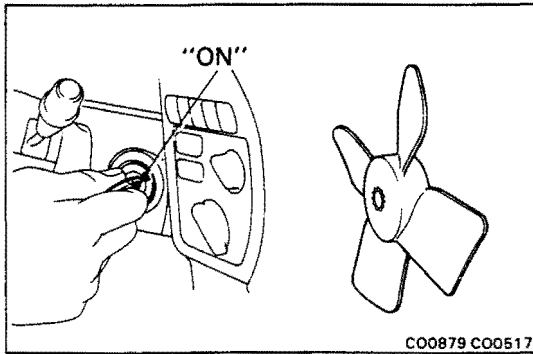

## ON-VEHICLE INSPECTION

HINT: 3S-GE engine (Europe) is equipped with No. 2 fan motor also.

### Low Temperature (Below 83°C (181°F)) No. 1 (Below 93°C (199°F)) No. 2

#### 1. TURN IGNITION SWITCH "ON"

Check that the cooling fan stops.

If not, check the cooling fan relays and water temp. switch, and check for a separated connector or severed wire between the cooling fan relay and water temp. switch.

#### 2. DISCONNECT WATER TEMP. SWITCH CONNECTOR

Check that the cooling fan rotates.

If not, check the cooling fan relays, cooling fan, engine main relay and fuse, and check for a short circuit between the cooling fan relay and water temp. switch.

#### 3. CONNECT WATER TEMP. SWITCH CONNECTOR

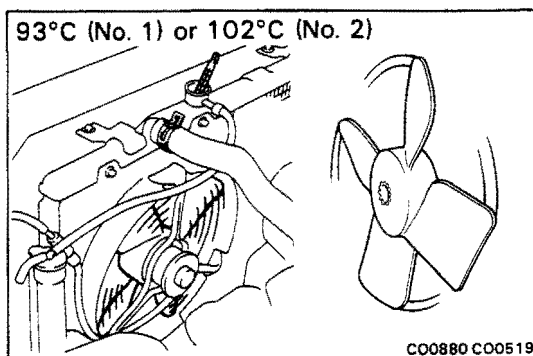
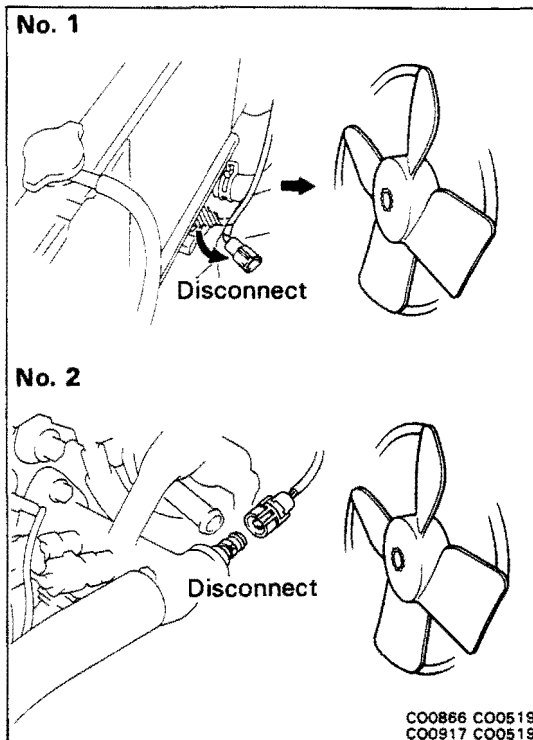

### High Temperature (Above 93°C (199°F)) No. 1 (Above 102°C (216°F)) No. 2

#### 4. START ENGINE

(a) Raise coolant temperature to above 93°C (199°F) or 102 °C (216°F)

(b) Check that the cooling fan rotates.

If not, replace the water temp. switch.

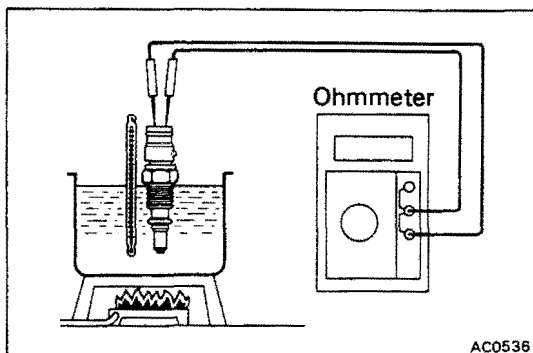

## INSPECTION OF ELECTRIC COOLING FAN COMPONENTS

### 1. INSPECT No. 1 WATER TEMP. SWITCH

- (a) Using an ohmmeter, check that there is no continuity between the terminals when the coolant temperature is above 93°C (199°F).
- (b) Using an ohmmeter, check that there is continuity between the terminals when the coolant temperature is below 83°C (181°F).

If continuity is not as specified, replace the switch.

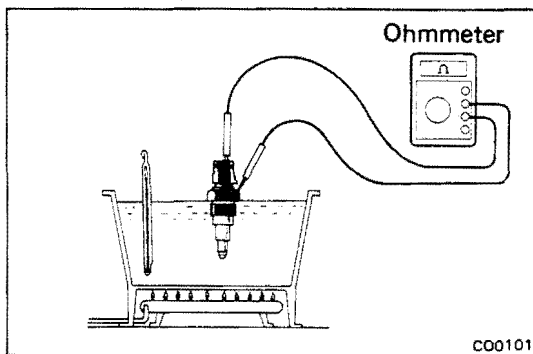

### 2. (3S-GE EUROPE) INSPECT No. 2 WATER TEMP. SWITCH

LOCATION: In the water outlet

- (a) Using an ohmmeter, check that there is no continuity between the terminal and switch body when the coolant temperature is above 102°C (216°F).
- (b) Using an ohmmeter, check that there is continuity between the terminal and switch body when the coolant temperature is below 93°C (199°F).

If continuity is not as specified, replace the switch.

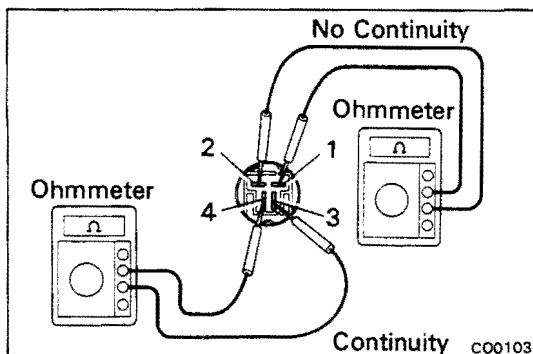

### 3. INSPECT No. 1 COOLING FAN RELAY

LOCATION: In the No. 2 junction block

#### A. Inspect relay continuity

- (a) Using an ohmmeter, check that there is continuity between terminals 1 and 2.
- (b) Check that there is continuity between terminals 3 and 4.

If continuity is not as specified, replace the relay.

#### B. Inspect relay operation

- (a) Apply battery voltage across terminals 1 and 2.
- (b) Using an ohmmeter, check that there is no continuity between terminals 3 and 4.

If operation is not as specified, replace the relay.

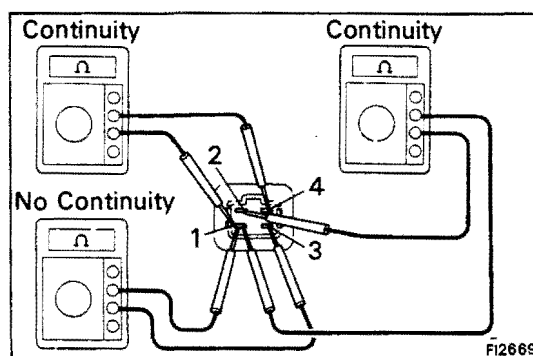
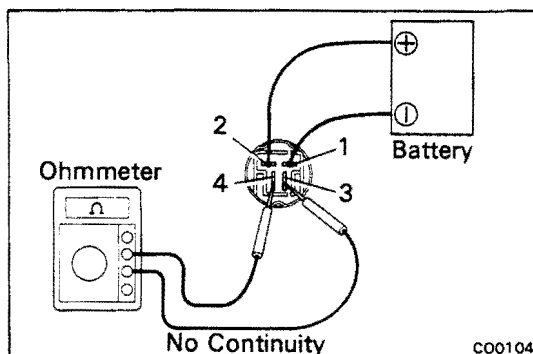

### 4. (3S-GE EUROPE) INSPECT No. 2 COOLING FAN RELAY

LOCATION: In the No. 5 relay block

#### A. Inspect relay continuity

- (a) Using an ohmmeter, check that there is continuity between terminals 1 and 4.
- (b) Check that there is continuity between terminals 1 and 2.
- (c) Check that there is no continuity between terminals 1 and 3.

If continuity is not as specified, replace the relay.

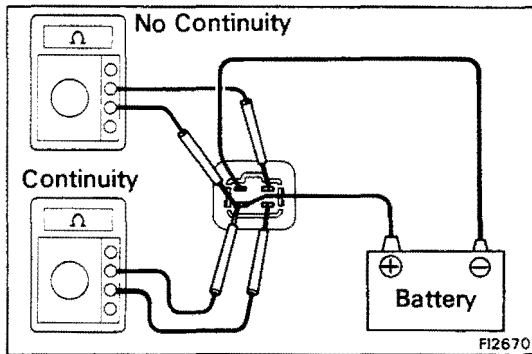
**B. Inspect relay operation**

- (a) Apply battery voltage to terminals 1 and 2.
- (b) Using an ohmmeter, check that there is continuity between terminals 1 and 3.
- (c) Check that there is no continuity between terminals 1 and 4.

If operation is not as specified, replace the relay.

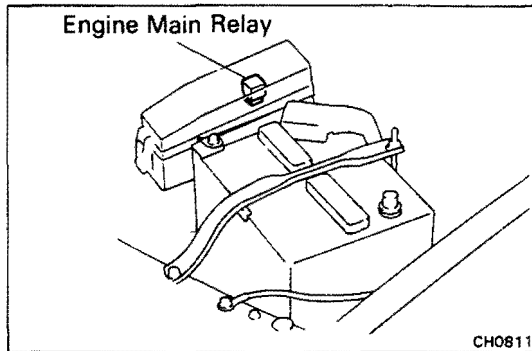
**5. INSPECT ENGINE MAIN RELAY**

LOCATION: In the engine compartment relay box.

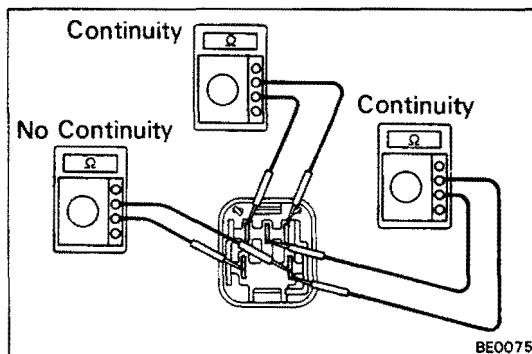
**A. Inspect Relay Continuity**

- (a) Using an ohmmeter, check that there is continuity between terminals 1 and 3.
- (b) Check that there is continuity between terminals 2 and 4.
- (c) Check that there is continuity between terminals 4 and 5.

If continuity is not as specified, replace the relay.

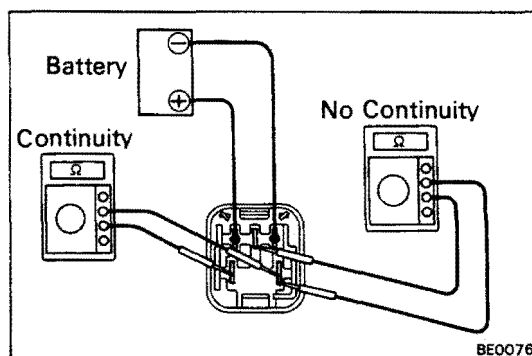
**B. Inspect Relay Operation**

- (a) Apply battery voltage across terminals 1 and 3.
- (b) Using an ohmmeter, check that there is continuity between terminals 4 and 5.
- (c) Check that there is no continuity between terminals 2 and 4.

If operation is not as specified, replace the relay.

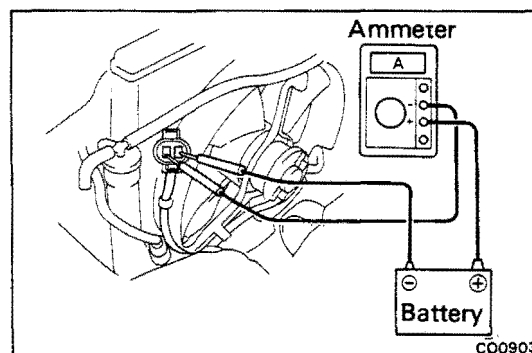
**6. INSPECT COOLING FAN**

- (a) Connect battery and ammeter to the cooling fan connector.
- (b) Check that the cooling fan rotates smoothly, and check the reading on the ammeter.

Standard amperage:

80W Type 5.4 – 7.4 A  
120W Type 8.8 – 10.8 A

# DESCRIPTION

This engine utilizes a pressurized forced circulation cooling system which includes a thermostat equipped with a by-pass valve mounted on the inlet side.

## 3S-GTE

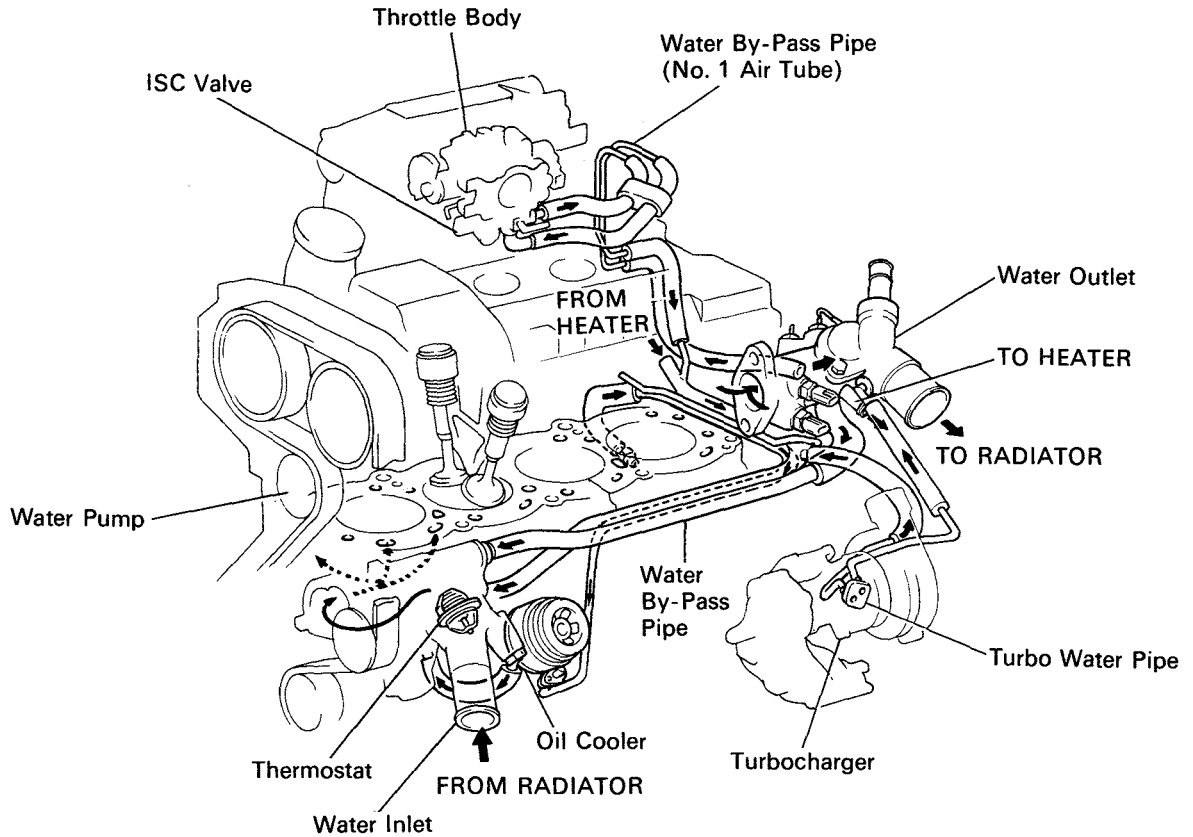

C00980

## 5S-FE

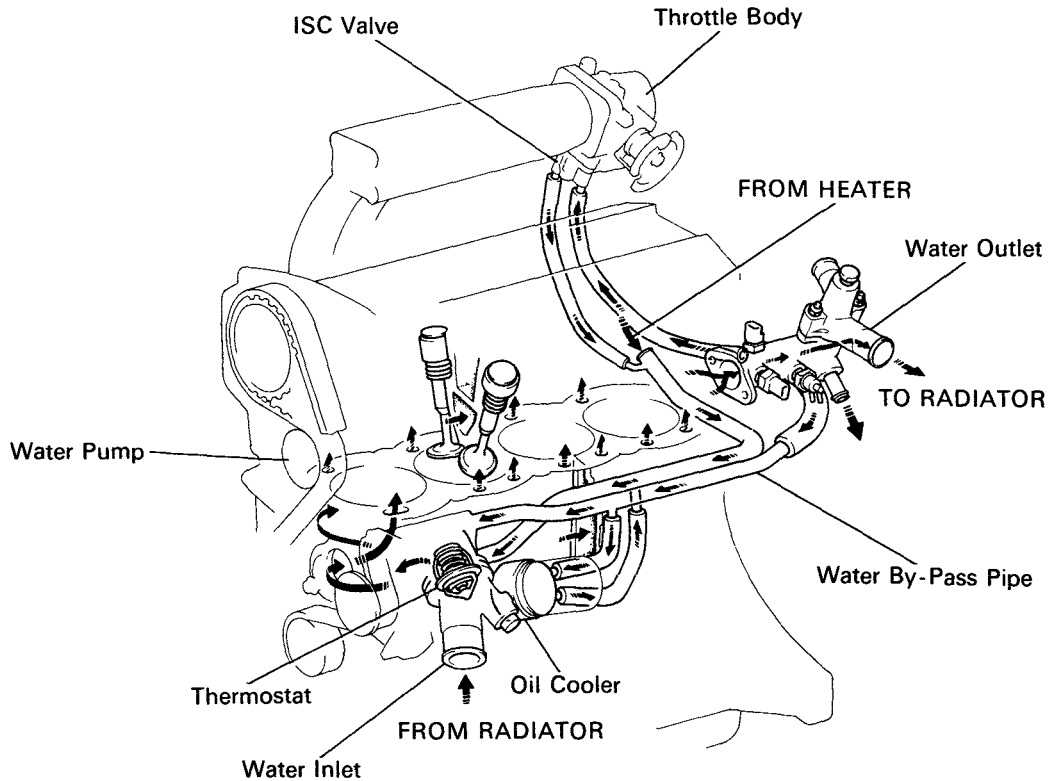

C00981

The cooling system is composed of the water jacket (inside the cylinder block and cylinder head), radiator, water pump, thermostat, electric fan, hoses and other components.

Coolant which is heated in the water jacket is pumped to the radiator, through which an electric fan blows air to cool the coolant as it passes through. Coolant which has been cooled is then sent back to the engine by the water pump, where it cools the engine.

The water jacket is a network of channels in the shell of the cylinder block and cylinder head through which coolant passes. It is designed to provide adequate cooling of the cylinders and combustion chambers which become heated during engine operation.

## **RADIATOR**

The radiator performs the function of cooling the coolant which has passed through the water jacket and become hot, and it is mounted in the front of the vehicle. The MR2 radiator is different from that in other models, in that it is a cross flow type in which the coolant flows horizontally. It includes side tanks and a core which connects them. The inlet for coolant from the water jacket and the drain cock for draining out coolant are located in the left tank. The outlet coolant and an air drain, which facilitates the supply of coolant to the engine are located in the right tank. The core contains many tubes through which coolant flows from left tank to the right tank as well as cooling fins which radiate heat away from the coolant in the tubes. Air sucked in by the electric cooling fan, as well as the wind generated by the vehicle's travel, passes through the radiator, cooling the coolant heated by the water jacket as it passes through the tubes in the core. Models with automatic transmission include an automatic transmission fluid cooler incorporated into the cooling pipes. A fan with an electric motor is mounted behind the radiator to assist the flow of air through the radiator. The fan operates when the coolant temperature becomes high in order to prevent it from becoming too high.

## **RADIATOR CAP**

The radiator cap is a pressure type cap which seals the radiator, resulting in pressurization of the radiator as the coolant expands. The pressurization prevents the coolant from boiling even when the coolant temperature exceeds 100°C (212°F). A relief valve (pressurization valve) and a vacuum valve (negative pressure valve) are built into the radiator cap. The relief valve opens and lets steam escape through the overflow pipe when the pressure generated inside the cooling system exceeds the limit (coolant temperature: 110 – 120°C, 230 – 248°F, pressure; 0.3 – 1.0 kg/cm<sup>2</sup>, 4.3 – 14.2 psi, 29.4 – 98.1 kPa). The vacuum valve opens to alleviate the vacuum which develops in the coolant system after the engine is stopped and the coolant temperature drops. The valve's opening allows the coolant in the reservoir tank to return to the cooling system.

## **RESERVOIR TANK**

The reservoir tank is used to catch coolant which overflows the cooling system as a result of volumetric expansion when the coolant is heated. The coolant in the reservoir tank returns to the radiator when the coolant temperature drops, thus keeping the radiator full at all times and avoiding needless coolant loss. Check the reservoir tank level to learn if the coolant needs to be replenished.

## **WATER PUMP**

The water pump is used for forced circulation of coolant through the cooling system. It is mounted on the front of the cylinder block and driven by a timing belt.

## **THERMOSTAT**

The thermostat has a wax type by-pass valve and is mounted in the water inlet housing. The thermostat includes a type of automatic valve operated by fluctuations in the coolant temperature. This valve closes when the coolant temperature drops, preventing the circulation of coolant through the engine and thus permitting the engine to warm up rapidly. The valve opens when the coolant temperature has risen, allowing the circulation of coolant. Wax inside the thermostat expands when heated and contracts when cooled. Heating the wax thus generates pressure which overpowers the force of the spring which keeps the valve closed, thus opening the valve. When the wax cools, its contraction causes the force of the spring to take effect once more, closing the valve. The thermostat in this engine operates at a temperature of 82°C (180°F).

## TROUBLESHOOTING

Problem	Possible cause	Remedy	Page
Engine overheats	Dirt, leaves or insects in radiator or condenser	Clean radiator or condenser	CO-16
	Hoses, water pump, thermostat housing, radiator, heater, core plugs or head gasket leakage	Repair as necessary	
	Thermostat faulty	Check thermostat	CO-14
	Incorrect ignition timing	Reset timing	IG-17, 22
	Electric cooling system faulty	Inspect electric cooling system	CO-22, 33
	Radiator hose plugged or rotted	Replace hose	
	Water pump faulty	Replace water pump	CO-10
	Radiator plugged or cap faulty	Check radiator and cap	CO-16
	Cylinder head or block cracked or water passage clogged	Repair as necessary	

**HINT:** Removal of the thermostat would have an adverse effect, causing a lowering of cooling efficiency. Do not remove the thermostat, even if the engine tends to overheat.

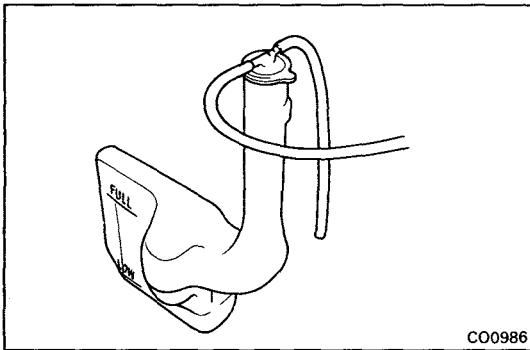

## ENGINE COOLANT CHECK

### 1. CHECK ENGINE COOLANT LEVEL AT RESERVE TANK

The coolant level should be between the "LOW" and "FULL" lines.

If low, check for leaks and add coolant up to the "FULL" line.

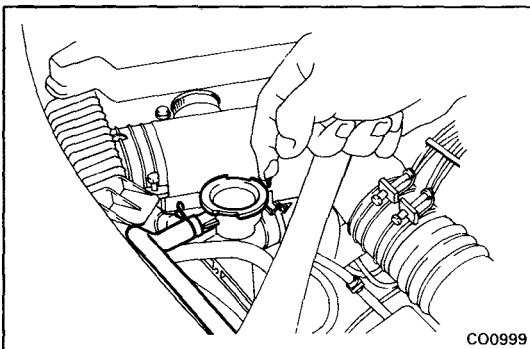

### 2. CHECK ENGINE COOLANT QUALITY

There should not be any excessive deposits of rust or scales around the radiator (water filler) cap or water filler hole, and the coolant should be free from oil.

If excessively dirty, replace the coolant.



# REPLACEMENT OF ENGINE COOLANT

## ENGINE COOLANT CIRCUIT

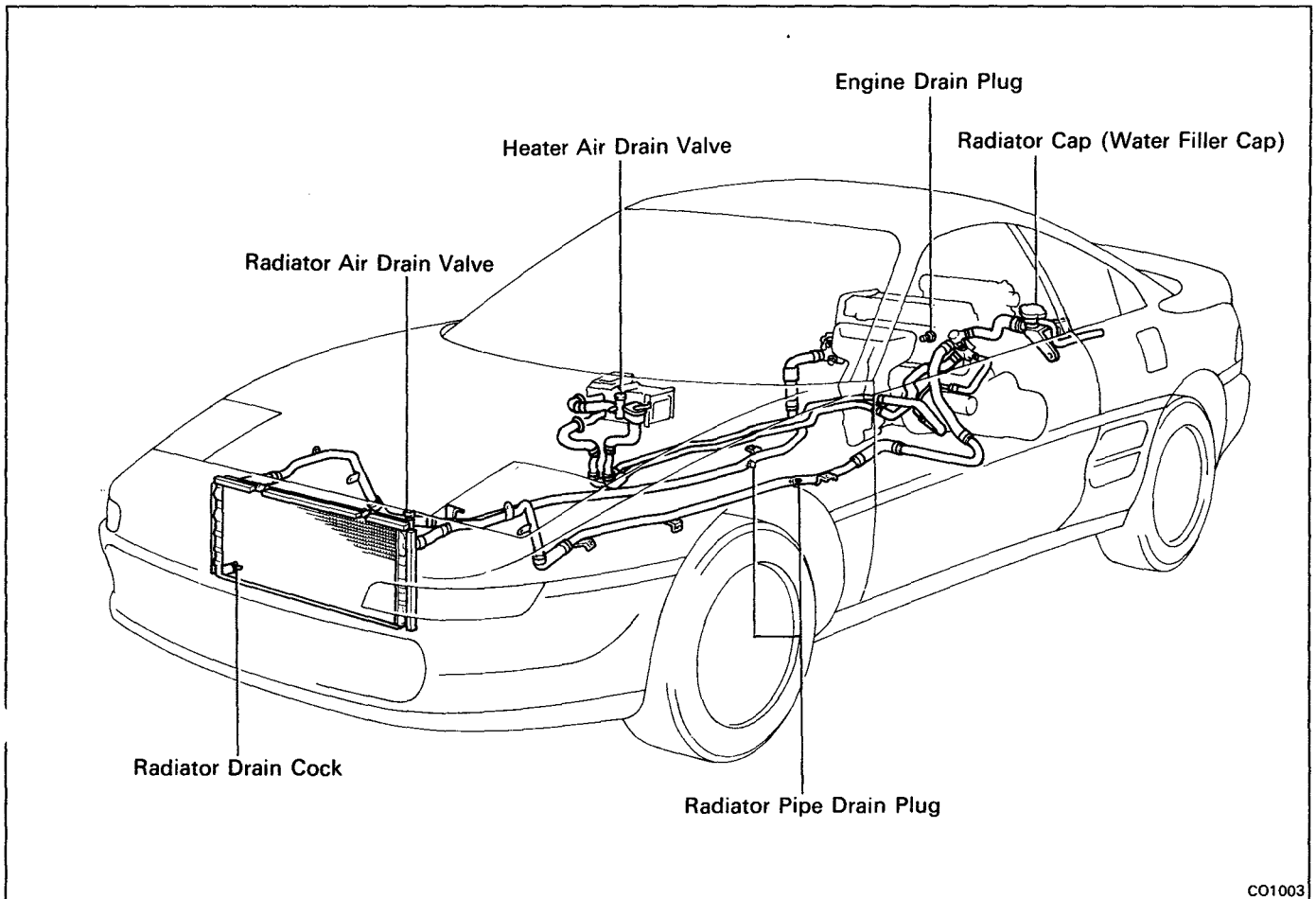

### NOTICE:

- To avoid the danger of burns, do not begin work until the engine and coolant are properly cooled down.
- To ensure that coolant is poured in properly, perform the operation at a level area. Performing work with the vehicle inclined may cause improper removal of coolant or improper air removal when pouring coolant.
- When replacement has been performed, check the water level in the water filler and reservoir tank once or twice within 500 km (311 miles) of driving or within one week.

### DRAINAGE OF ENGINE COOLANT

1. REMOVE REAR FUEL TANK PROTECTOR
2. REMOVE FRONT LUGGAGE UNDER COVERS

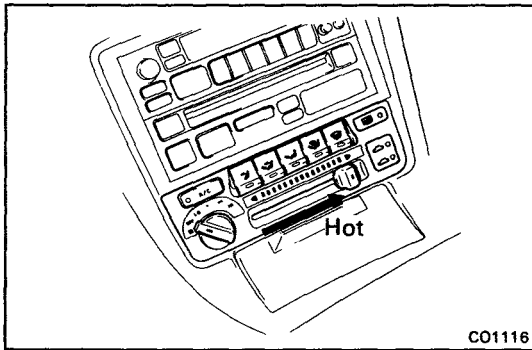

### 3. DRAIN ENGINE COOLANT

- (a) Set the heater control lever to hot.

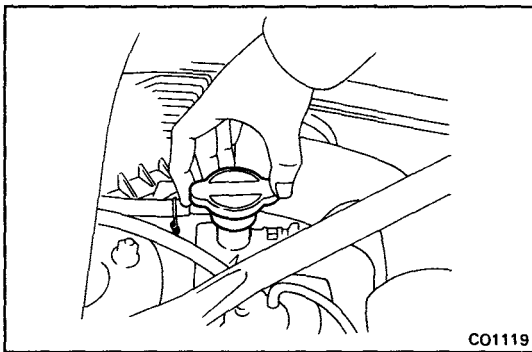

- (b) Remove the radiator cap.

**CAUTION:** To avoid the danger of being burned, do not remove the radiator cap while the engine and radiator are still hot, as fluid and steam can be blown out under pressure.

- (c) Drain the coolant from the radiator cock and engine drain plug (engine drain plug are at the rear left of engine block) and two radiator pipe plugs.

- (d) Close the drain cocks.

**Torque:**

<b>Engine drain plug</b>	
3S-GTE	250 kg-cm (18 ft-lb, 25 N·m)
5S-FE	130 kg-cm (9 ft-lb, 13 N·m)
<b>Radiator drain plug</b>	170 kg-cm (12 ft-lb, 17 N·m)

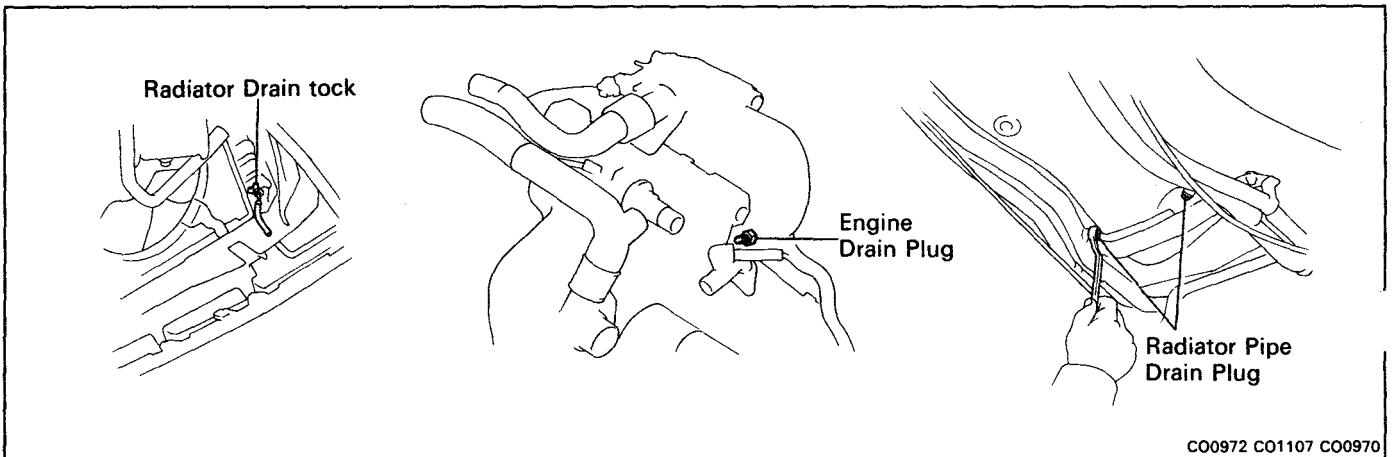

## REFILL OF ENGINE COOLANT

1. REMOVE SPARE TIRE
2. REMOVE FRONT LUGGAGE COMPARTMENT TRIM
3. REMOVE UPPER RADIATOR SUPPORT SEAL

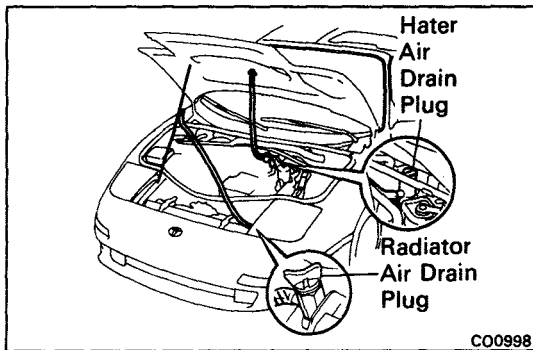

### 4. SET SERVICE HOSES

- (a) Connect the service hoses to the radiator air drain and heater valve.
- (b) Suspend the opposite end to the service hose connected to radiator air drain to the front hood stay.
- (c) Suspend the opposite end to the service hose connected to heater valve to the front hood.

**NOTICE:** Do not close-off or pinch any of the service hoses.

### 5. FILL WITH ENGINE COOLANT

- (a) Set the heater control lever to hot.

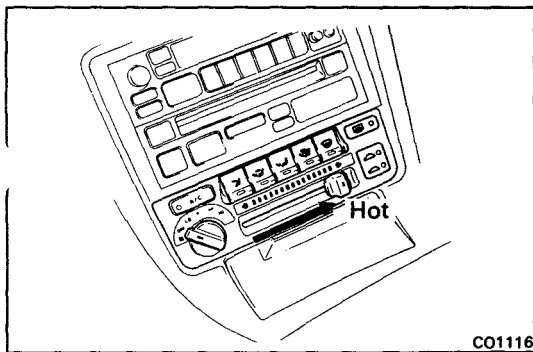

- (b) Open the radiator and heater air drain plugs above three turns.

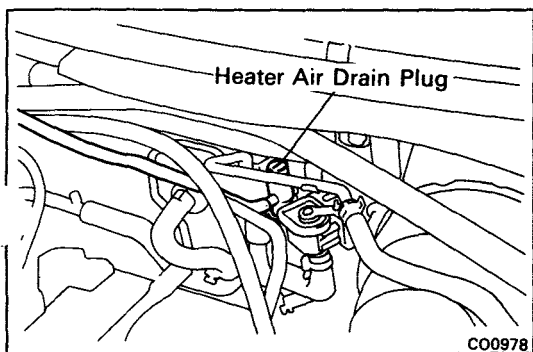
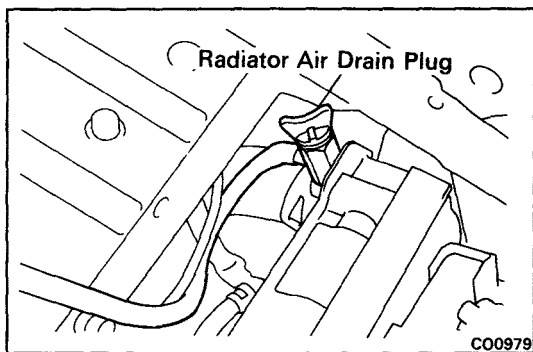

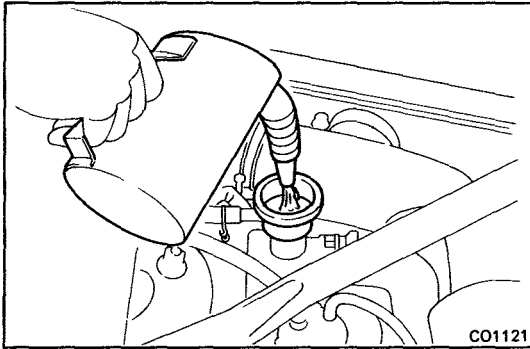

(c) Slowly fill the water filler with coolant.

- Use a good brand of ethylene-glycol base coolant, mixed according to the manufacturer's directions.
- Using coolant which includes more than 50 % ethylene-glycol (but not more than is recommended).

**NOTICE:**

- Do not use alcohol type coolant.
- The coolant should be mixed with demineralized water or distilled water.

**Capacity (w/ Heater):**

- |        |  |
|--------|--|
| 3S-GTE | 13.6 liters (14.4 US qts, 12.0 Imp. qts) |
| 5S-FE  | 13.0 liters (13.7 US qts, 11.4 Imp. qts) |

(d) Check that air is absent from the air drain plugs of the radiator and heater while filling the water filler inlet to the top with coolant.

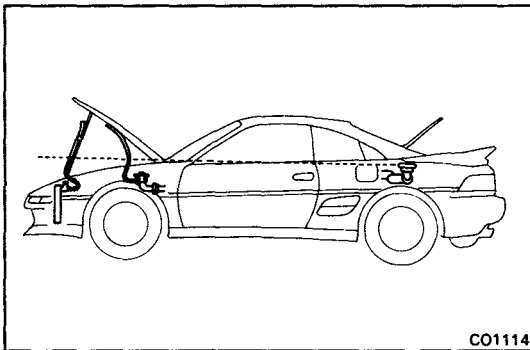

(e) Visually check that the level of coolant in the air drain service hoses of the radiator and heater are the same as in the water filler.

**NOTICE:** If the water level in the air drain service hose is clearly lower, air removal has been incomplete so check if the service hose is crushed or bent, then perform step (c).

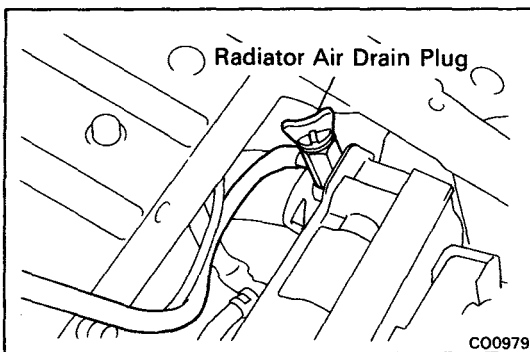

(f) When the coolant level in the air drain service hoses stops dropping, close the air drain plugs of the radiator and heater.

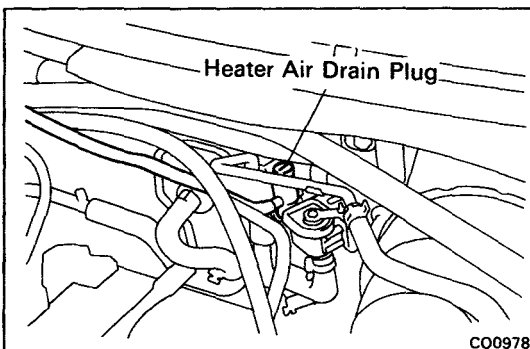

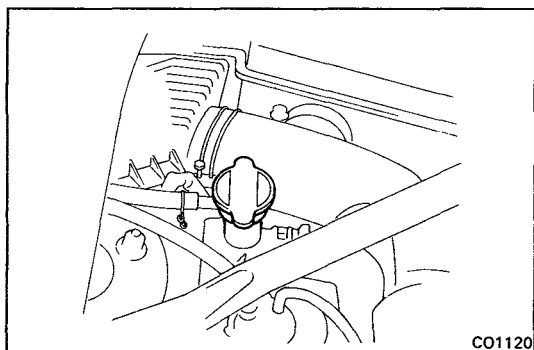

(g) Fasten the radiator cap to the first stop point.

**NOTICE:** Do not tighten the radiator cap completely (to the second stop point).

(h) Start the engine and run at fast idle for approx. 3 minutes, and stop the engine.

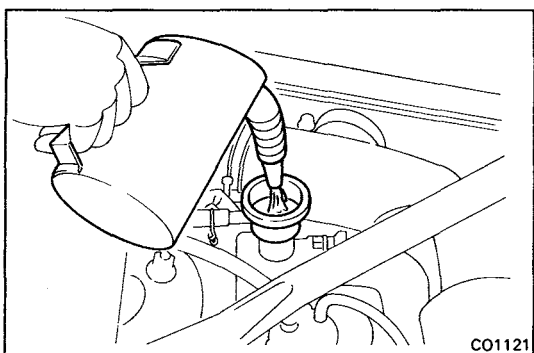

(i) Add more coolant and repeat steps (h) and (i).

**HINT:** By performing steps (h) and (i), 0.2 – 0.5 liters (0.2 – 0.5 US qts, 0.2 – 0.4 Imp. qts) can normally be added.

(j) Check that the coolant level in the water filler has not dropped.

If the coolant level has dropped, add coolant and repeat the steps from (g) onward.

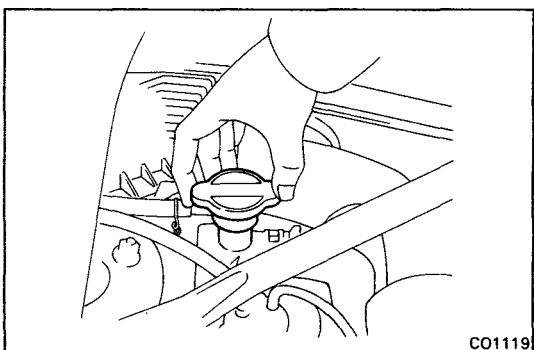

(k) Completely tighten the radiator cap.

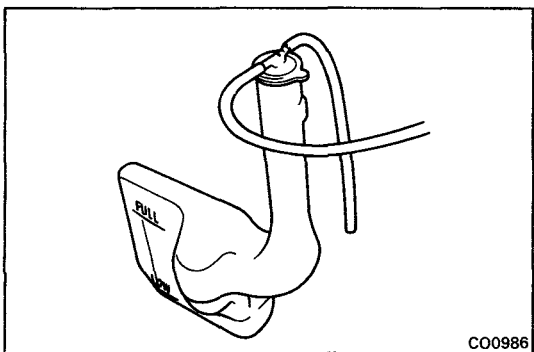

(l) Fill coolant into the reservoir tank up to the "FULL" line.

6. INSTALL UPPER RADIATOR SUPPORT SEAL
7. INSTALL FRONT LUGGAGE COMPARTMENT TRIM
8. INSTALL SPARE TIRE
9. INSTALL REAR FUEL TANK PROTECTOR
10. INSTALL FRONT LUGGAGE UNDER COVERS

# WATER PUMP COMPONENTS

3S-GTE

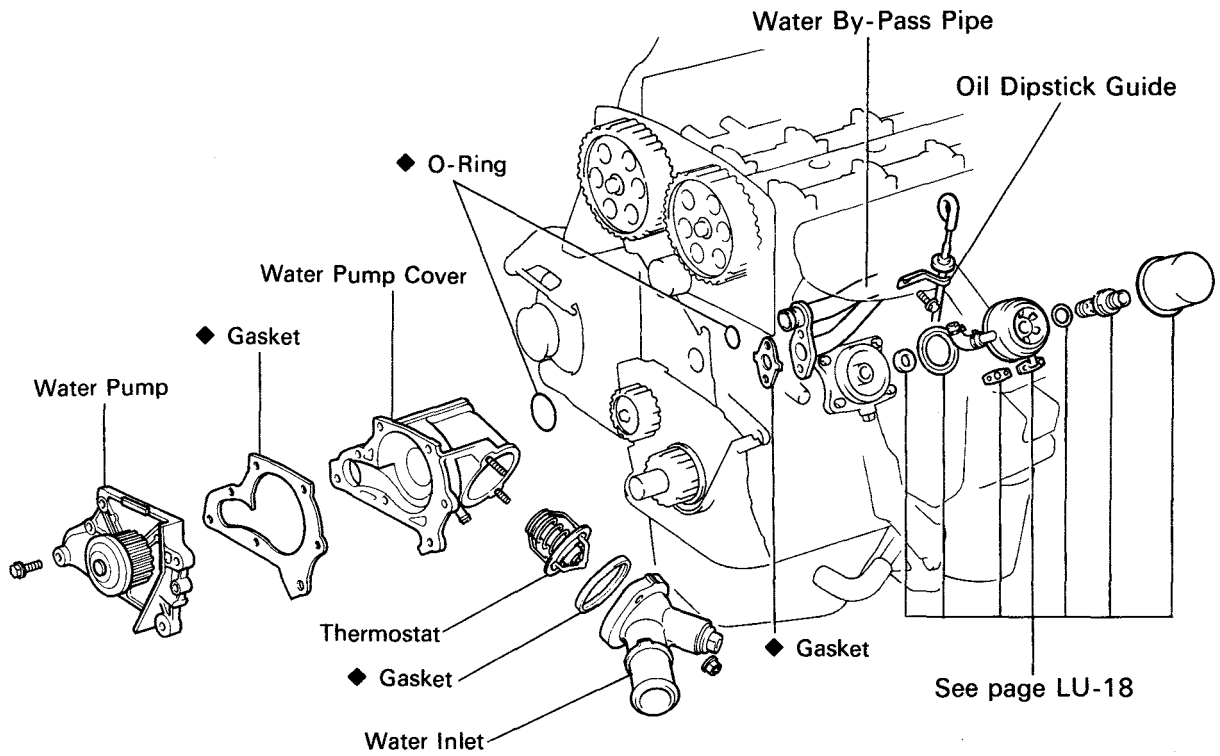

◆ Non-reusable part

C01117

5S-FE

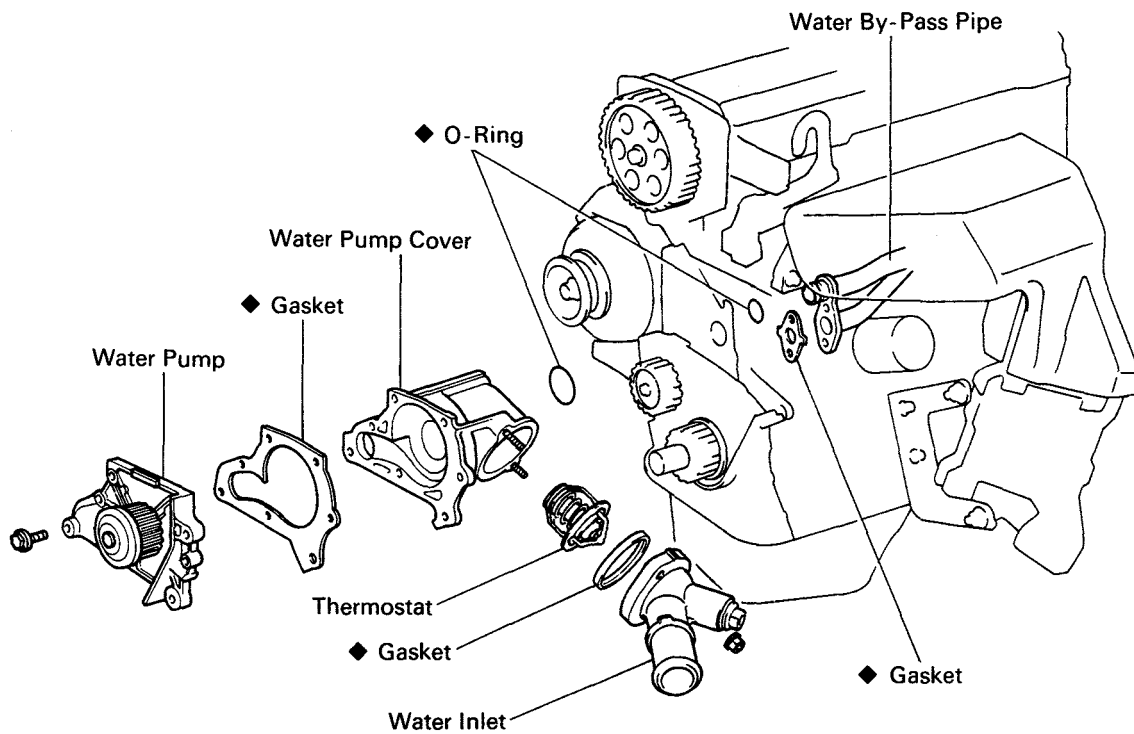

◆ Non-reusable part

C01113

**REMOVAL OF WATER PUMP**

(See page CO-10)

1. DRAIN ENGINE COOLANT (See page CO-6)
2. DISCONNECT RADIATOR HOSE FROM WATER INLET
3. REMOVE TIMING BELT  
3S-GTE (See steps 1 to 25 on pages EM-26 to 31)  
5S-FE (See steps 1 to 21 on pages EM-47 to 52)
4. (5S-FE)  
REMOVE A/C COMPRESSOR IDLER PULLEY  
(See steps 31 ((b) to (d)) on page EM-187)
5. REMOVE NO.2 IDLER PULLEY  
3S-GTE (See step 27 on page EM-32)  
5S-FE (See step 23 on page EM-52)
6. (5S-FE)  
REMOVE TIMING BELT TENSION SPRING
7. (3S-GTE)  
REMOVE OIL COOLER  
(See steps 7 to 10 on pages EM-18 and 19)
8. REMOVE WATER PUMP AND WATER PUMP COVER ASSEMBLY
  - (a) Remove the two nuts holding the water pump to the water by-pass pipe.

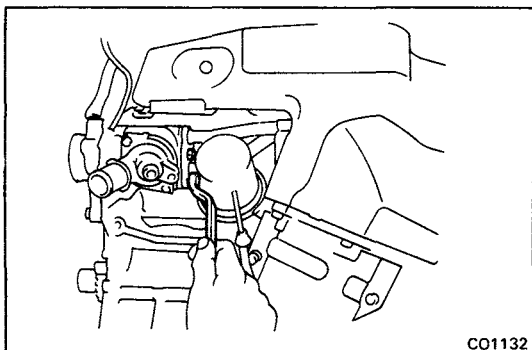

CO1132

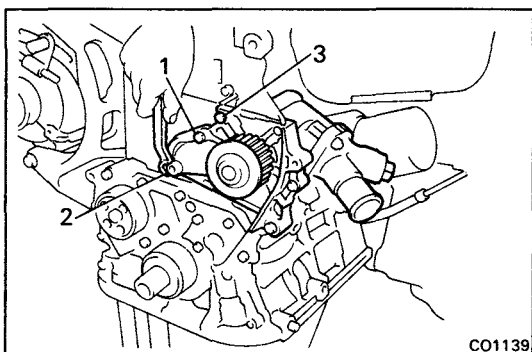

CO1139

- (b) Remove the three bolts in the sequence shown.
- (c) Pull out the water pump together with the water pump cover.
- (d) Remove the gasket and two O-rings from the water pump and water by-pass pipe.

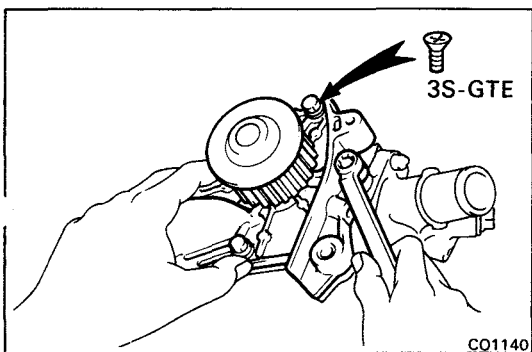

CO1140

9. SEPARATE WATER PUMP AND WATER PUMP COVER  
Remove the three bolts, water pump and gasket from the water pump cover.
10. REMOVE WATER INLET AND THERMOSTAT FROM WATER PUMP COVER (See step 4 on page CO-14)

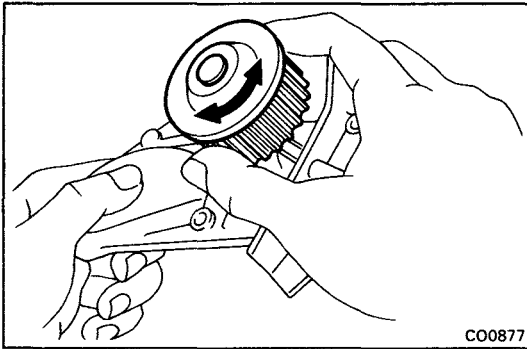

## INSPECTION OF WATER PUMP

### INSPECT WATER PUMP

Turn the pulley and check that the water pump bearing moves smoothly and quietly.

## INSTALLATION OF WATER PUMP

(See page CO-10)

1. **INSTALL THERMOSTAT AND WATER INLET TO WATER PUMP COVER**  
(See steps 1 and 2 on page CO-15)

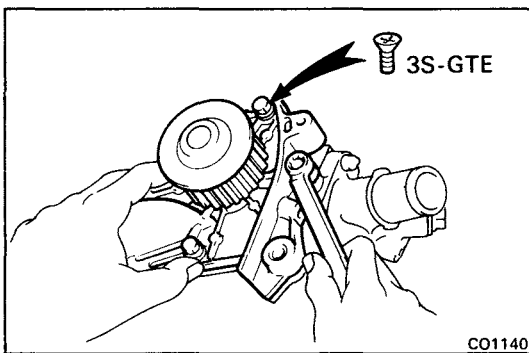

2. **ASSEMBLE WATER PUMP AND WATER PUMP COVER**

Install a new gasket and the water pump to the pump cover with the three bolts.

Torque: 95 kg-cm (82 in.-lb, 9.3 N·m)

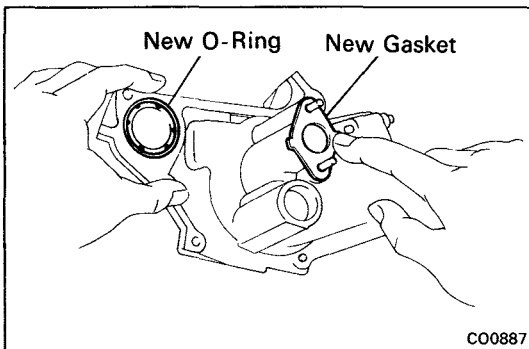

3. **INSTALL WATER PUMP AND WATER PUMP COVER ASSEMBLY**

(a) Install new O-ring and gasket to the water pump cover.

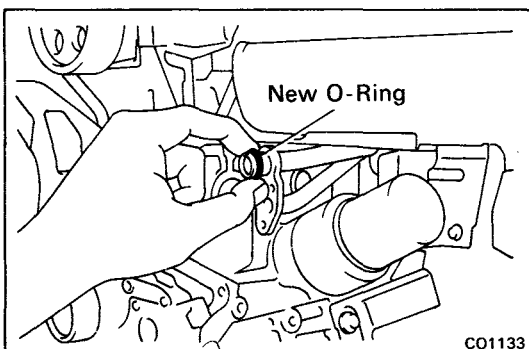

(b) Install a new O-ring to the water by-pass pipe.



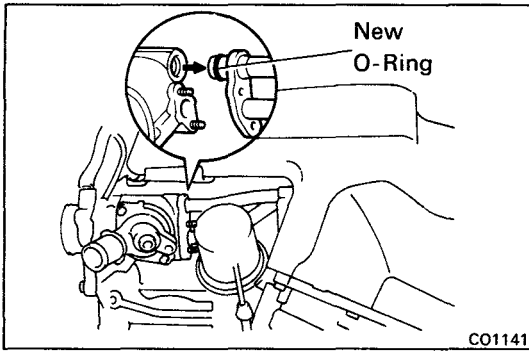

- (c) Apply soapy water to the O-ring on the water by-pass pipe.
- (d) Connect the pump cover to the water by-pass pipe. Do not install the nuts yet.

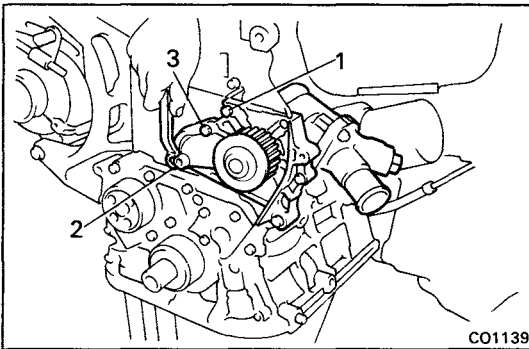

- (e) Install the water pump with the three bolts. Tighten the bolts in the sequence shown.

**Torque:**

**3S-GTE 80 kg-cm (69 in.-lb, 8.0 N·m)**  
**5S-FE 95 kg-cm (82 in.-lb, 9.3 N·m)**

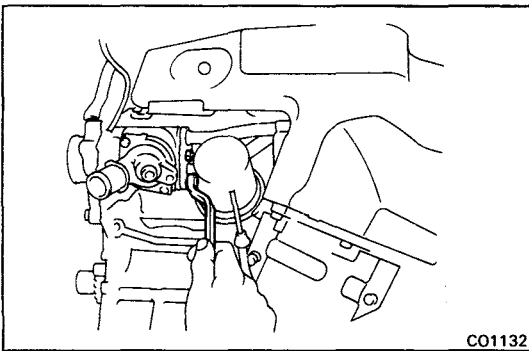

- (f) Install the two nuts holding the water pump cover to the water by-pass pipe.

**Torque:**

**3S-GTE 120 kg-cm (9 ft-lb, 12 N·m)**  
**5S-FE 95 kg-cm (82 in.-lb, 9.3 N·m)**

4. **(3S-GTE)**  
**INSTALL OIL COOLER**  
**(See steps 2 to 5 on pages LU-21 and 22)**
5. **(5S-FE)**  
**INSTALL TIMING BELT TENSION SPRING**
6. **INSTALL NO.2 IDLER PULLEY**  
**3S-GTE (See step 3 on page EM-35)**  
**5S-FE (See step 3 on page EM-55)**
7. **(5S-FE)**  
**INSTALL A/C COMPRESSOR IDLER PULLEY**  
**(See step 13 ((b) to (e)) on page EM-221)**
8. **INSTALL TIMING BELT**  
**3S-GTE (See steps 5 to 32 on pages EM-35 to 41)**  
**5S-FE (See steps 5 to 26 on pages EM-55 to 60)**
9. **CONNECT RADIATOR HOSE TO WATER INLET**
10. **FILL WITH ENGINE COOLANT (See page CO-7)**

# THERMOSTAT

## REMOVAL OF THERMOSTAT

1. DRAIN ENGINE COOLANT (See page CO-6)
2. DISCONNECT RADIATOR HOSE FROM WATER INLET
3. (3S-GTE)  
DISCONNECT OIL DIPSTICK GUIDE FROM WATER INLET (See step 8 on page LU-19)
4. REMOVE WATER INLET AND THERMOSTAT
  - (a) Remove the two nuts and water inlet from the water pump.
  - (b) Remove the thermostat.
  - (c) Remove the gasket from the thermostat.

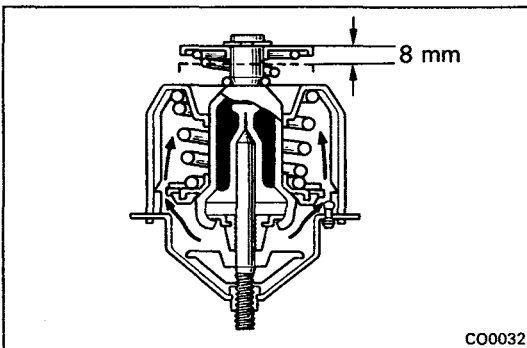
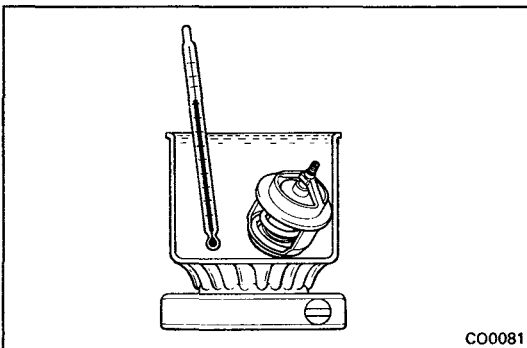
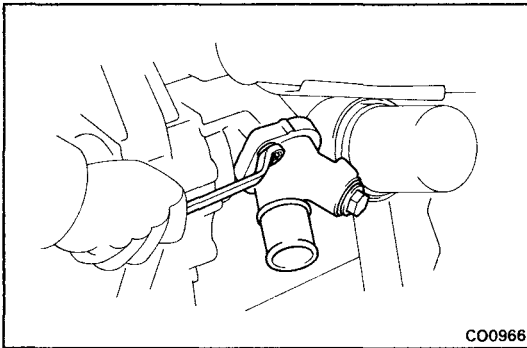

## INSPECTION OF THERMOSTAT

### INSPECT THERMOSTAT

**HINT:** The thermostat is numbered with the valve opening temperature.

- (a) Immerse the thermostat in water and gradually heat the water.

- (b) Check the valve opening temperature.

**Valve opening temperature:**  
80 – 84°C (176 – 183°F)

If the valve opening temperature is not as specified, replace the thermostat.

- (c) Check the valve lift.

**Valve lift:**  
8 mm (0.31 in.) or more at 95°C (203°F)

If the valve lift is less than specification, replace the thermostat.

- (d) Check that the valve spring is tight when the thermostat is fully closed.

If necessary, replace the thermostat.

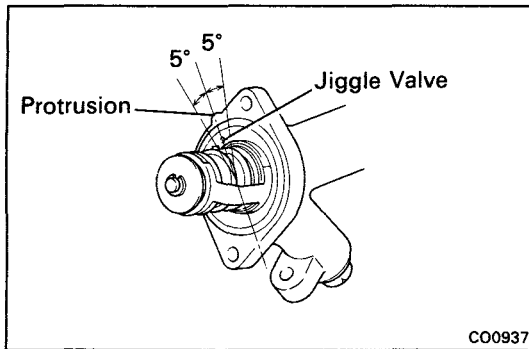

## INSTALLATION OF THERMOSTAT

### 1. PLACE THERMOSTAT IN WATER PUMP

- (a) Install a new gasket to the thermostat.
- (b) Align the jiggle valve of the thermostat with the upper side of the stud bolt, and insert the thermostat in the water pump.

**HINT:** The jiggle valve may be set within 5° of either side of the prescribed position.

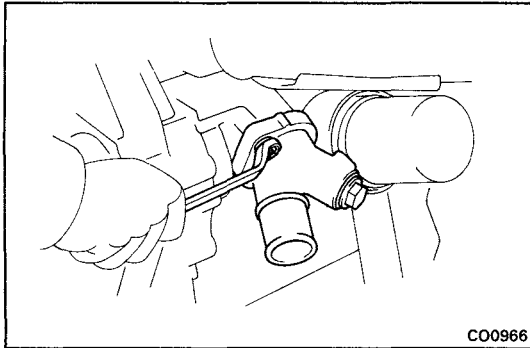

### 2. INSTALL WATER INLET

Install the water inlet with the two nuts.

**Torque:**

3S-GTE	80 kg-cm (69 in.-lb, 7.8 N·m)
5S-FE	90 kg-cm (78 in.-lb, 8.8 N·m)

3. (3S-GTE)  
CONNECT OIL DIPSTICK GUIDE TO WATER INLET  
(See step 4 on page LU-22)
4. CONNECT RADIATOR HOSE TO WATER INLET
5. FILL WITH ENGINE COOLANT (See page CO-7)
6. START ENGINE AND CHECK FOR LEAKS

# RADIATOR

## CLEANING OF RADIATOR

Using water or a steam cleaner, remove any mud and dirt from the radiator core.

**NOTICE:** If using a high pressure type cleaner, be careful not to deform the fins of the radiator core. If the cleaner nozzle pressure is 30 – 35 kg/cm<sup>2</sup> (427 – 498 psi, 2,942 – 3,432), keep a distance at least 40 – 50 cm (15.75 – 19.69 in.) between the radiator core and cleaner nozzle.

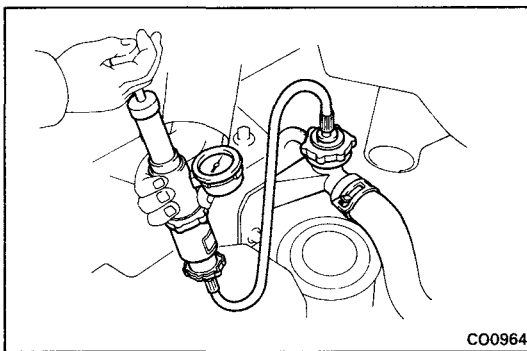
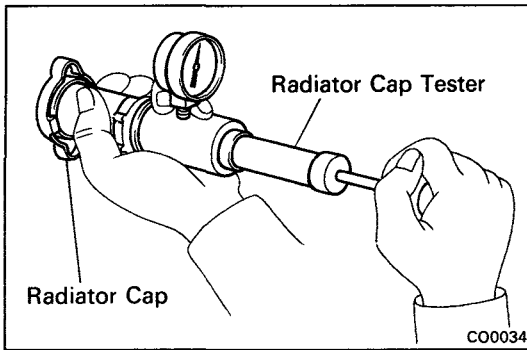

## INSPECTION OF RADIATOR

### 1. INSPECT RADIATOR (WATER FILLER) CAP

Using a radiator cap tester, pump the tester and measure the relief valve opening pressure.

**Standard opening pressure:**

0.75 – 1.05 kg/cm<sup>2</sup>  
(10.7 – 14.9 psi, 74 – 103 kPa)

**Minimum opening pressure:**

0.6 kg/cm<sup>2</sup> (8.5 psi, 59 kPa)

If the opening pressure is less than minimum, replace the radiator cap.

### 2. INSPECT COOLING SYSTEM FOR LEAKS

- (a) Fill the radiator with coolant and attach a radiator cap tester to the radiator (water filler) cap.
- (b) Warm up the engine.
- (c) Pump it to 1.2 kg/cm<sup>2</sup> (17.1 psi, 118 kPa), check that pressure does not drop.

If the pressure drops, check for leaks on the hoses, radiator or water pump. If no external leaks are found, check the heater core, cylinder block and head.

## REMOVAL OF RADIATOR

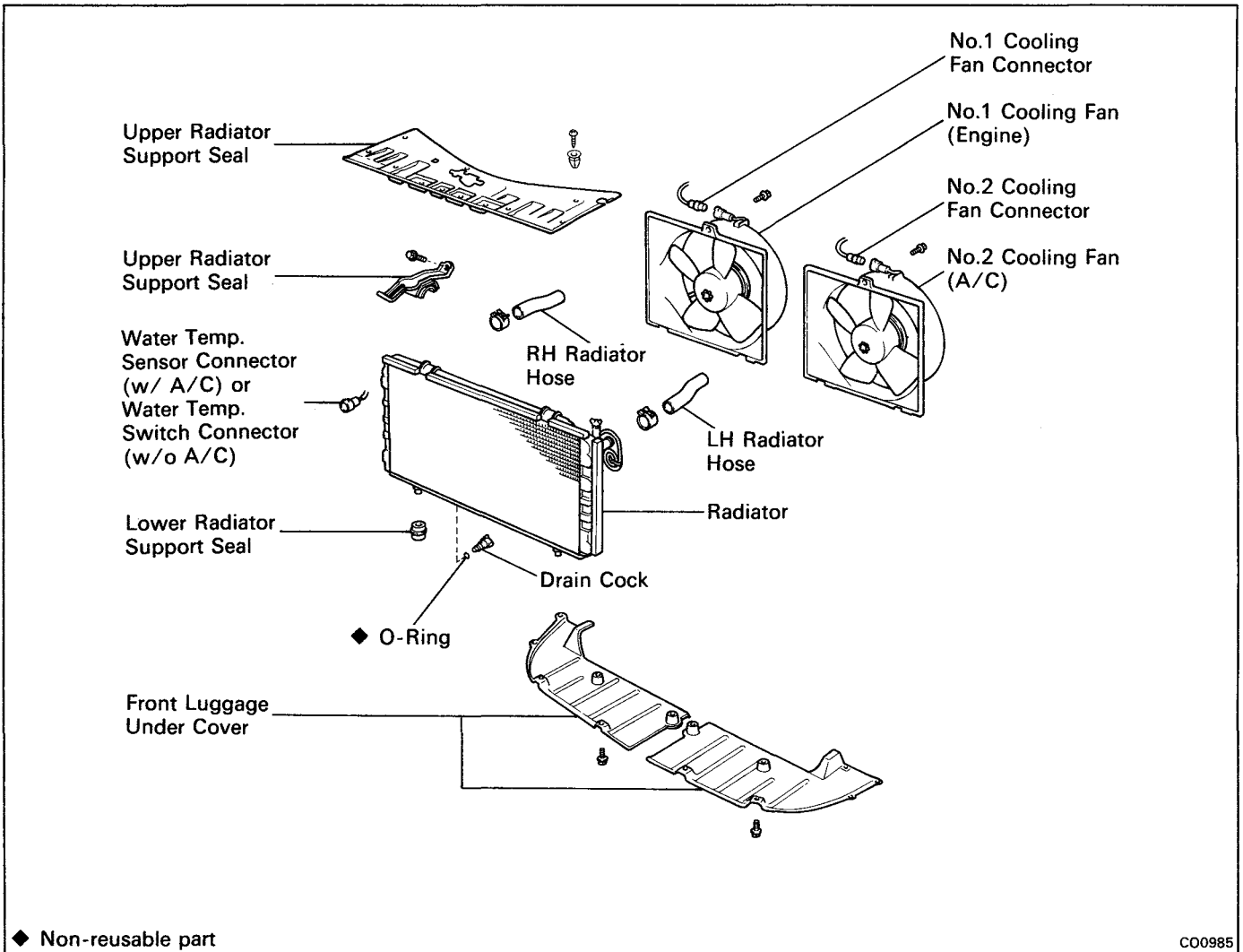

**1. DISCONNECT CABLE FROM NEGATIVE TERMINAL OF BATTERY**

**CAUTION:** Work must be started after approx. 20 seconds or longer from the time the ignition switch is turned to the "LOCK" position and the negative (-) terminal cable is disconnected from the battery.

**2. REMOVE FRONT LUGGAGE UNDER COVERS**

**3. DRAIN ENGINE COOLANT (See page CO-6)**

**4. REMOVE UPPER RADIATOR SUPPORT SEAL**

Remove the seven clips and support seal.

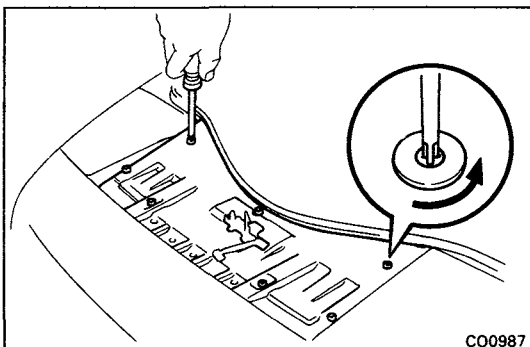

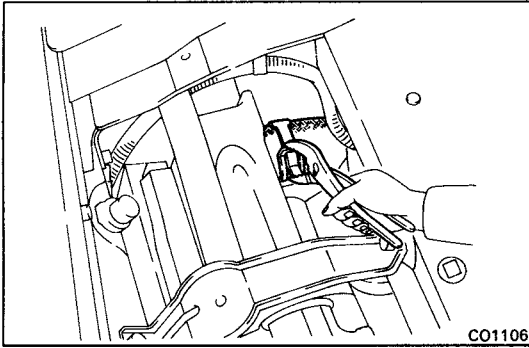

**5. DISCONNECT RADIATOR HOSES**

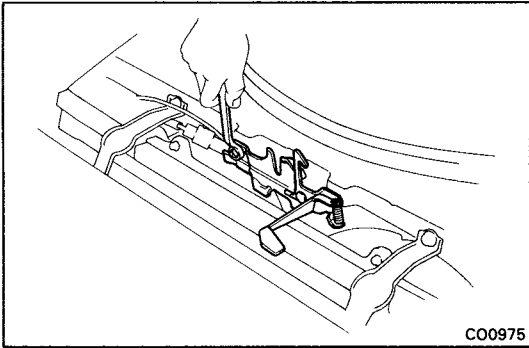

**6. REMOVE FRONT HOOD LOCK**

Remove the two bolts and hood lock.

**7. DISCONNECT RADIATOR COOLING FAN CONNETORS**

**8. DISCONNECT WATER TEMPERATURE SENSOR (w/A/C) or SWITCH (w/o A/C) CONNECTOR**

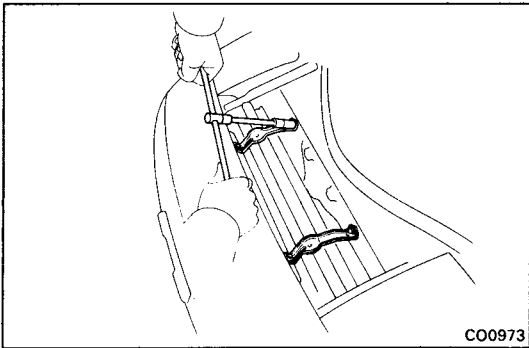

**9. REMOVE RADIATOR AND COOLING FANS**

(a) Remove the two bolts and upper support. Remove the two upper supports.

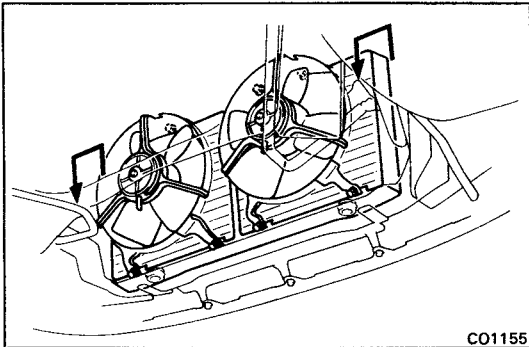

(b) Remove the radiator and two cooling fan assembly.

(c) Remove the two lower supports.

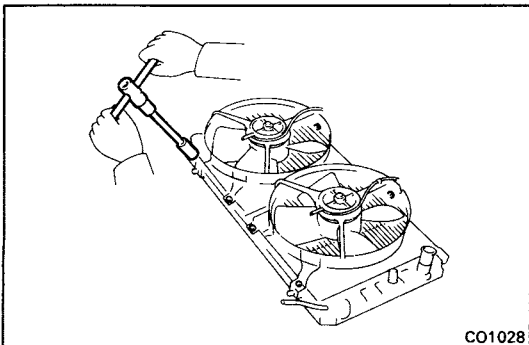

**10. REMOVE NO.1 AND NO.2 COOLING FANS FROM RADIATOR**

Remove the three bolts and cooling fan. Remove the two cooling fans.

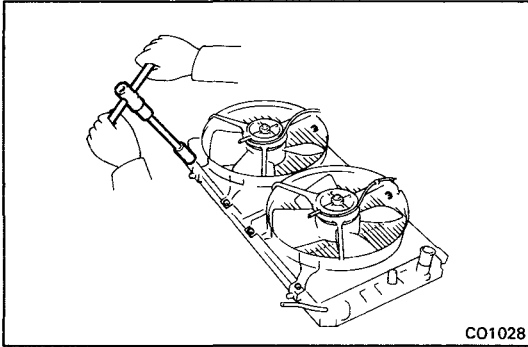

## INSTALLATION OF RADIATOR

(See page CO-17)

### 1. INSTALL NO.1 AND NO.2 COOLING FANS TO RADIATOR

Install the cooling fan with the three bolts. Install the two cooling fans.

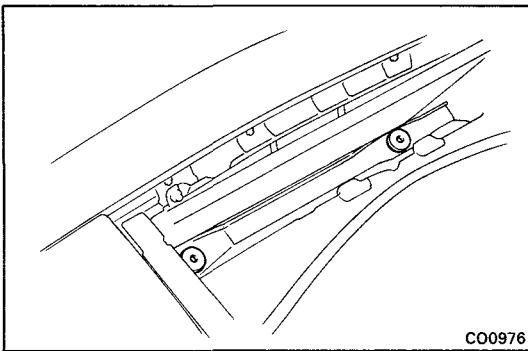

### 2. INSTALL RADIATOR AND COOLING FANS

(a) Place the two lower supports in position on the body.

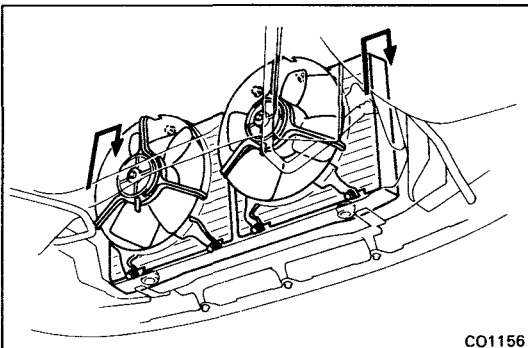

(b) Place the radiator and two cooling fan assembly in position on the body.

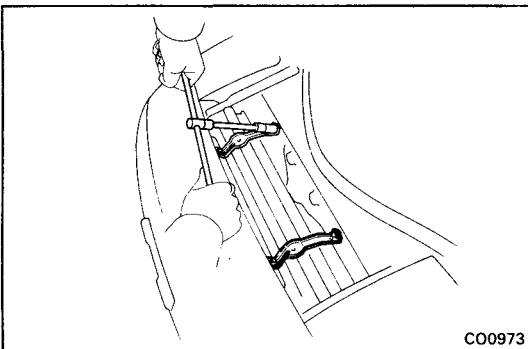

(c) Install the upper supports with the two bolts. Install the two upper supports.

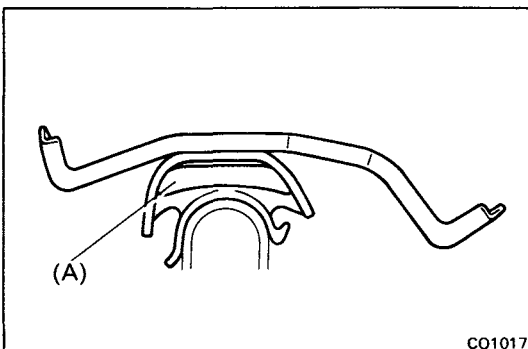

**HINT:** After installation, check that the rubber cushion (A) of the supports are not depressed.

### 3. CONNECT WATER TEMPERATURE SENSOR (w/ A/C) OR SWITCH (w/o A/C) CONNECTOR

### 4. CONNECT RADIATOR COOLING FAN CONNECTORS

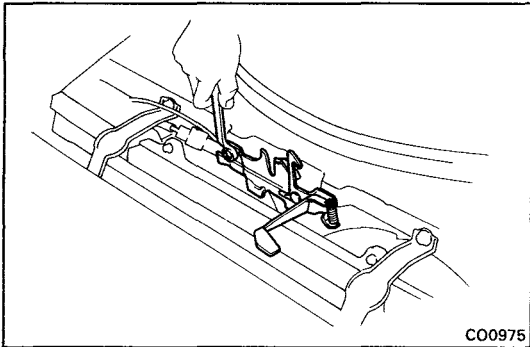
**5. INSTALL FRONT HOOD LOCK**

Install the hood lock with the two bolts.

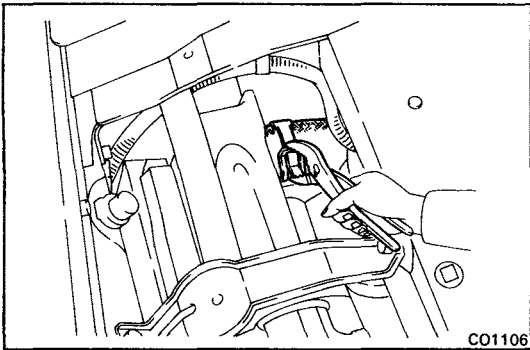
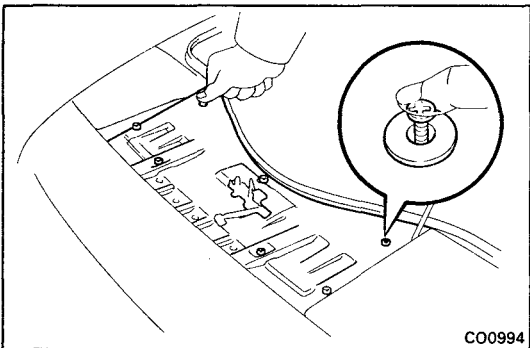
**6. CONNECT RADIATOR HOSES****7. CONNECT CABLE TO NEGATIVE TERMINAL OF BATTERY****8. FILL WITH ENGINE COOLANT (See page CO-7)****9. START ENGINE AND CHECK FOR LEAKS****10. INSTALL UPPER RADIATOR SUPPORT SEAL**

Install the support seal with the seven clips.

**11. INSTALL FRONT LUGGAGE UNDER COVERS**



# ELECTRIC COOLING FANS

## Radiator Cooling Fans (w/ A/C)

### SYSTEM CIRCUIT

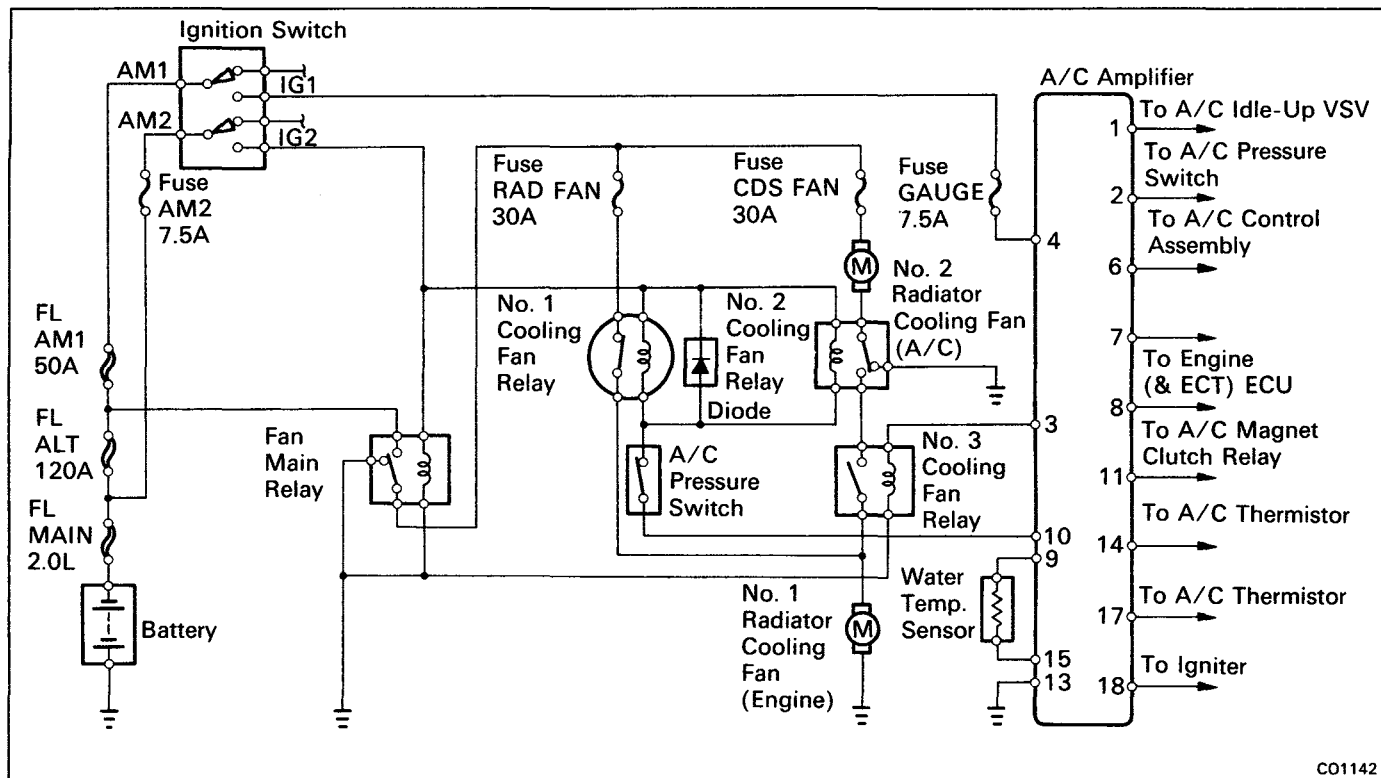

CO1142

### LOCATION OF RADIATOR COOLING FAN COMPONENTS

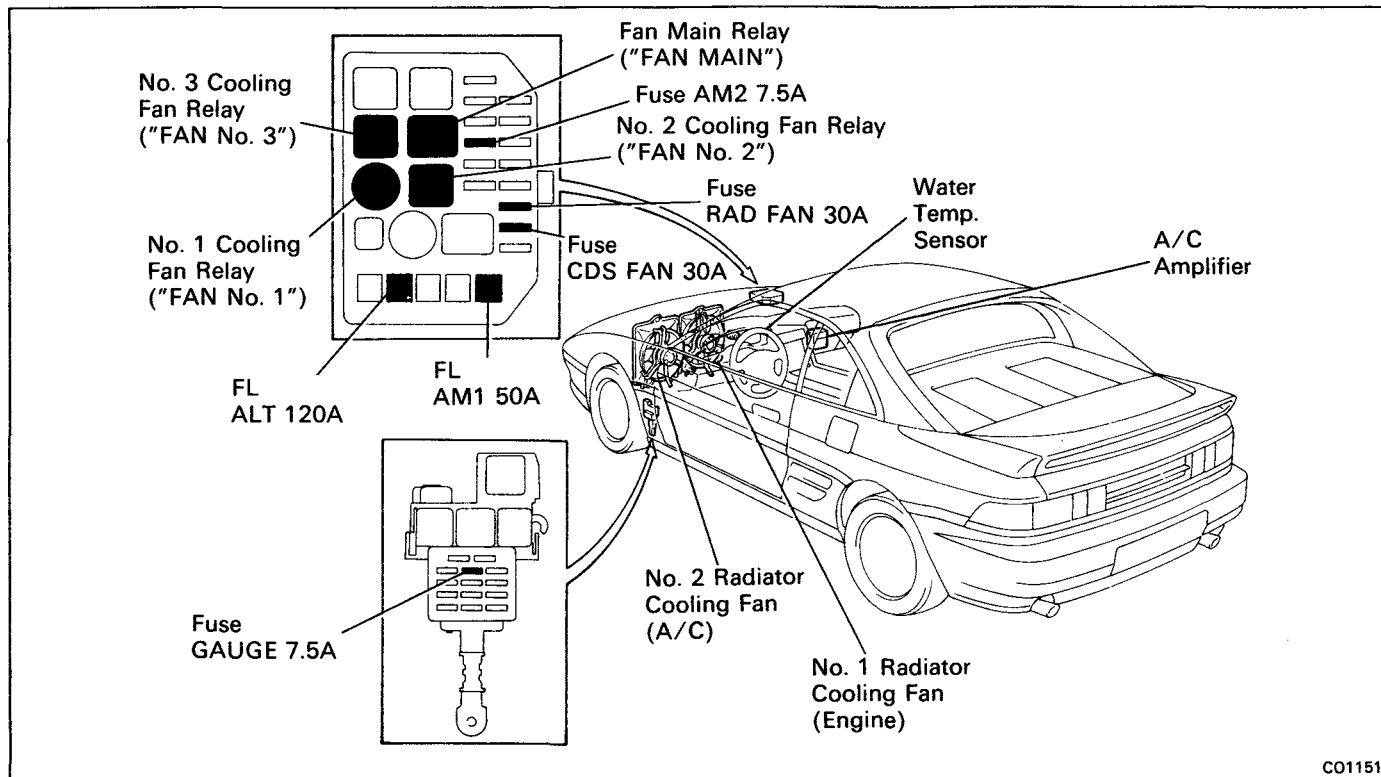

CO1151

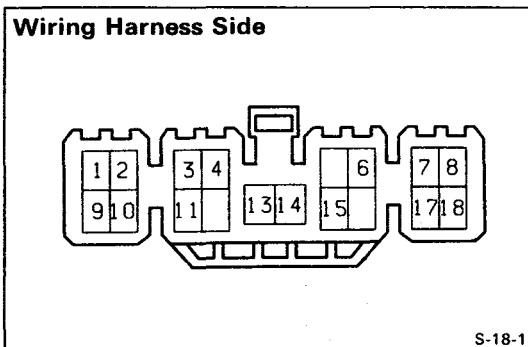
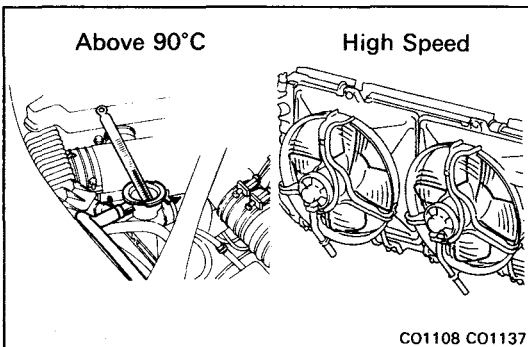
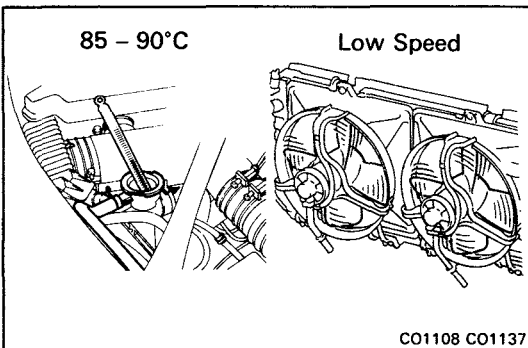
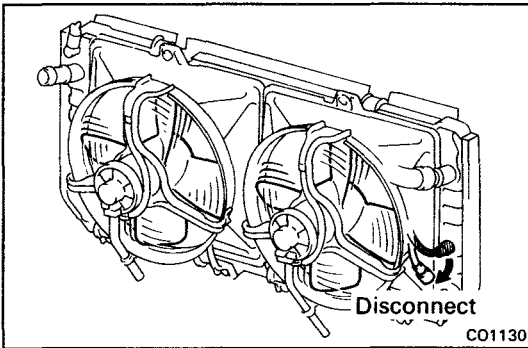
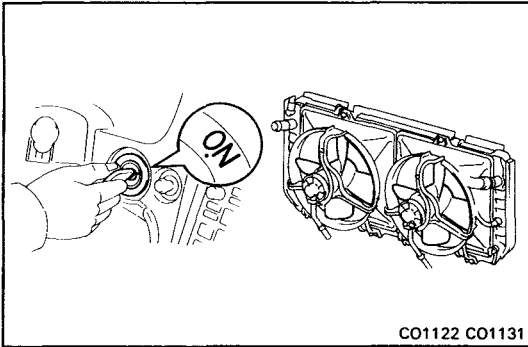

## ON-VEHICLE INSPECTION

### Low Temperature (Below 85°C (185°F))

#### 1. TURN IGNITION SWITCH "ON"

Check that the cooling fans stops.

If not, check the cooling fan relays and water temperature sensor, and check for a separated connector or severed wire between the cooling fan relay and water temperature sensor.

#### 2. DISCONNECT RADIATOR WATER TEMPERATURE SENSOR CONNECTOR

Check that the cooling fans rotates.

If not, check the fan main relay, cooling fan relays, A/C amplifier, cooling fan and fuses, and check for a short circuit between the cooling fan relay and water temperature sensor.

#### 3. CONNECT RADIATOR WATER TEMPERATURE SENSOR CONNECTOR

### High Temperature (85 – 90°C (185 – 194°F))

#### 4. START ENGINE

(a) Raise coolant temperature to 85 – 90°C (185 – 194°F).

(b) Check that the cooling fans rotates (at low speed).

If not, replace the water temperature sensor.

### High Temperature (Above 90°C (194°F))

#### 5. START ENGINE

(a) Raise coolant temperature to above 90°C (194°F).

(b) Check that the cooling fans rotates (at high speed).

If not, replace the water temperature sensor.

## INSPECTION OF RADIATOR COOLING FAN COMPONENTS

#### 1. INSPECT A/C AMPLIFIER FOR CIRCUIT

Disconnect the A/C amplifier connector, and check the connector on the wiring harness side as shown in the chart on the next page.

Check for	Tester connection	Condition	Specified value	
Continuity	3 – Ground	–	Continuity	
Voltage	4 – Ground	Ignition switch ON	Battery voltage	
Resistance	9 – 15	Coolant temp.	85°C (185°F)	Approx. 1.35 kΩ
			90°C (194°F)	Approx. 1.19 kΩ
			95°C (203°F)	Approx. 1.05 kΩ
Voltage	10 – Ground	Ignition switch ON	Battery voltage	
Continuity	13 – Ground	–	Continuity	

**2. INSPECT FAN MAIN RELAY ("FAN MAIN")**  
(See page CH-18)

Check the relay in the same way as the Ignition Main Relay.

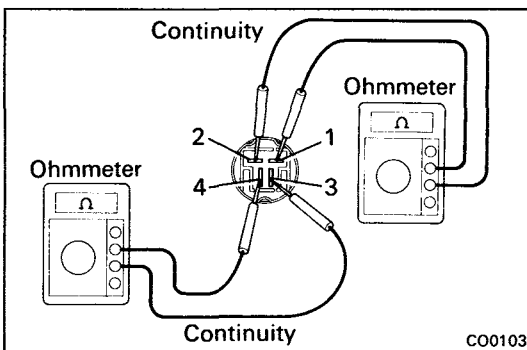

**3. INSPECT NO.1 COOLING FAN RELAY ("FAN NO.1")**

**A. Inspect relay continuity**

- (a) Using an ohmmeter, check that there is continuity between terminals 1 and 2.
- (b) Check that there is continuity between terminals 3 and 4.

If continuity is not as specified, replace the relay.

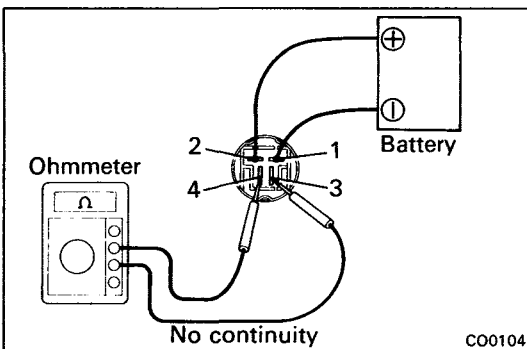

**B. Inspect relay operation**

- (a) Apply battery voltage across terminal 1 and 2.
- (b) Using an ohmmeter, check that there is no continuity between terminals 3 and 4.

If operation is not as specified, replace the relay.

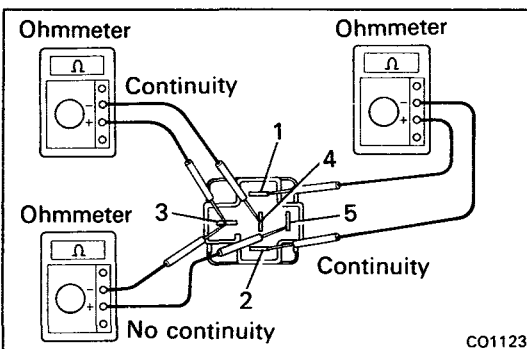

**4. INSPECT NO.2 COOLING FAN RELAY ("FAN NO.2")**

**A. Inspect relay continuity**

- (a) Using an ohmmeter, check that there is continuity between terminals 1 and 2.
- (b) Check that there is continuity between terminals 3 and 4.
- (c) Check that there is no continuity between terminals 3 and 5.

If continuity is not as specified, replace the relay.

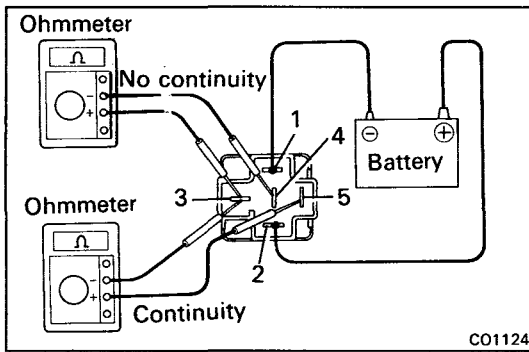
**B. Inspect relay operation**

- Apply battery voltage across terminal 1 and 2.
- Using an ohmmeter, check that there is no continuity between terminals 3 and 4.
- Check that there is continuity between terminals 3 and 5.

If operation is not as specified, replace the relay.

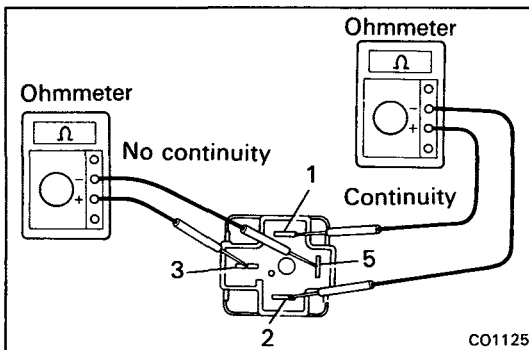
**5. INSPECT NO.3 COOLING FAN RELAY ("FAN NO.3")****A. Inspect relay continuity**

- Using an ohmmeter, check that there is continuity between terminals 1 and 2.
- Check that there is no continuity between terminals 3 and 5.

If continuity is not as specified, replace the relay.

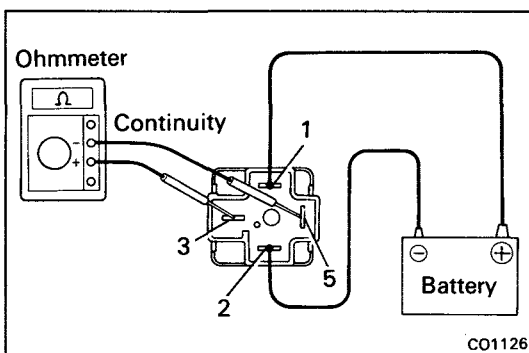
**B. Inspect relay operation**

- Apply battery voltage across terminal 1 and 2.
- Using an ohmmeter, check that there is continuity between terminals 3 and 5.

If operation is not as specified, replace the relay.

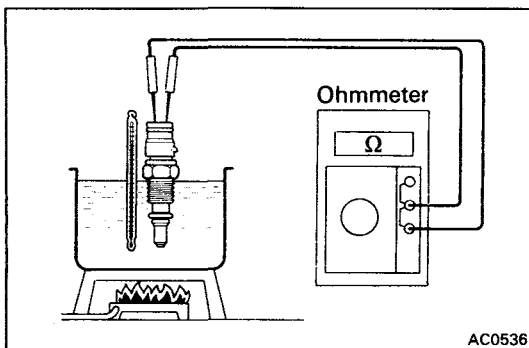
**6. INSPECT RADIATOR WATER TEMPERATURE SENSOR**

Using an ohmmeter, measure the resistance between the terminals.

**Resistance:**

Approx. 1.35 k $\Omega$  at 85°C (185°F)

Approx. 1.19 k $\Omega$  at 90°C (194°F)

Approx. 1.05 k $\Omega$  at 95°C (203°F)

If resistance is not as specified, replace the sensor.

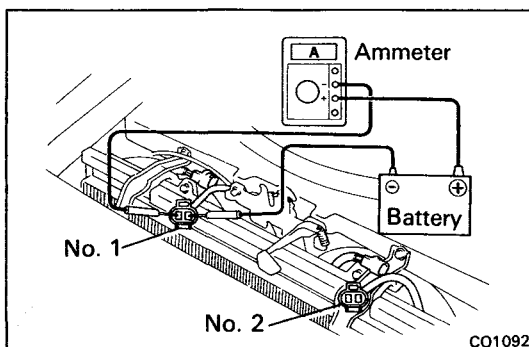
**7. INSPECT NO. 1 AND NO. 2 RADIATOR COOLING FANS**

- Connect battery and ammeter to the cooling fan connector.
- Check that the cooling fan rotates smoothly, and check the reading on the ammeter.

Standard amperage: M/T 5.8 – 7.4 A  
A/T 8.8 – 10.8 A

## REMOVAL OF RADIATOR COOLING FANS

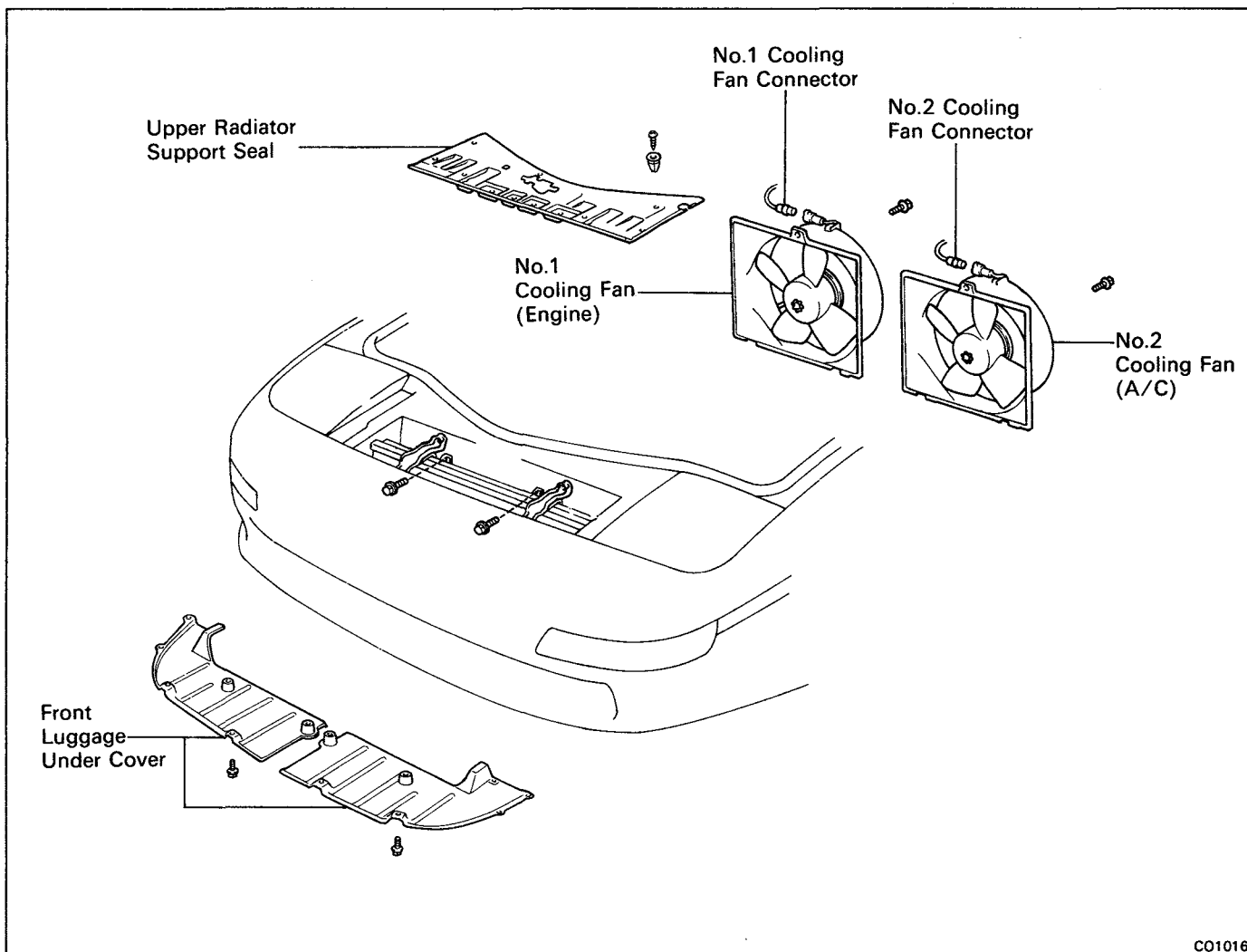

CO1016

**1. DISCONNECT CABLE FROM NEGATIVE TERMINAL OF BATTERY**

**CAUTION:** Work must be started after approx. 20 seconds or longer from the time the ignition switch is turned to the "LOCK" position and the negative (-) terminal cable is disconnected from the battery.

**2. DISCONNECT FRONT LUGGAGE UNDER COVERS**

**3. DISCONNECT UPPER RADIATOR SUPPORT SEAL (See step 4 on page CO-17)**

**4. DISCONNECT RADIATOR COOLING FAN CONNECTORS**

**5. REMOVE RADIATOR COOLING FANS**

Remove the three bolts and cooling fan. Remove the two cooling fans.

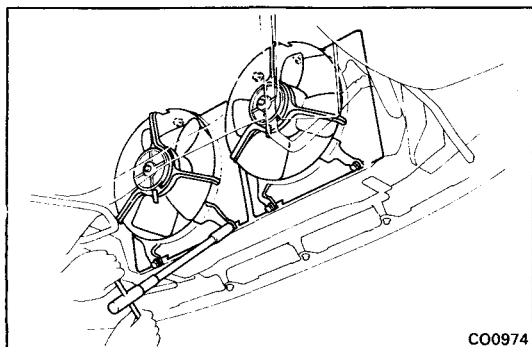

CO0974

## COMPONENTS

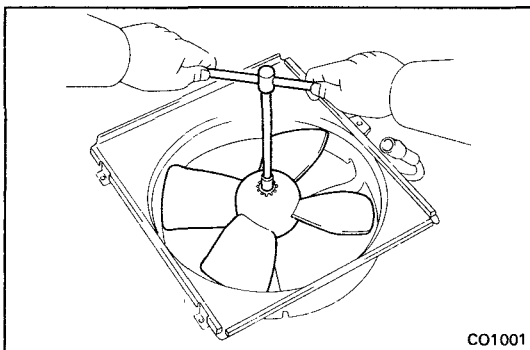
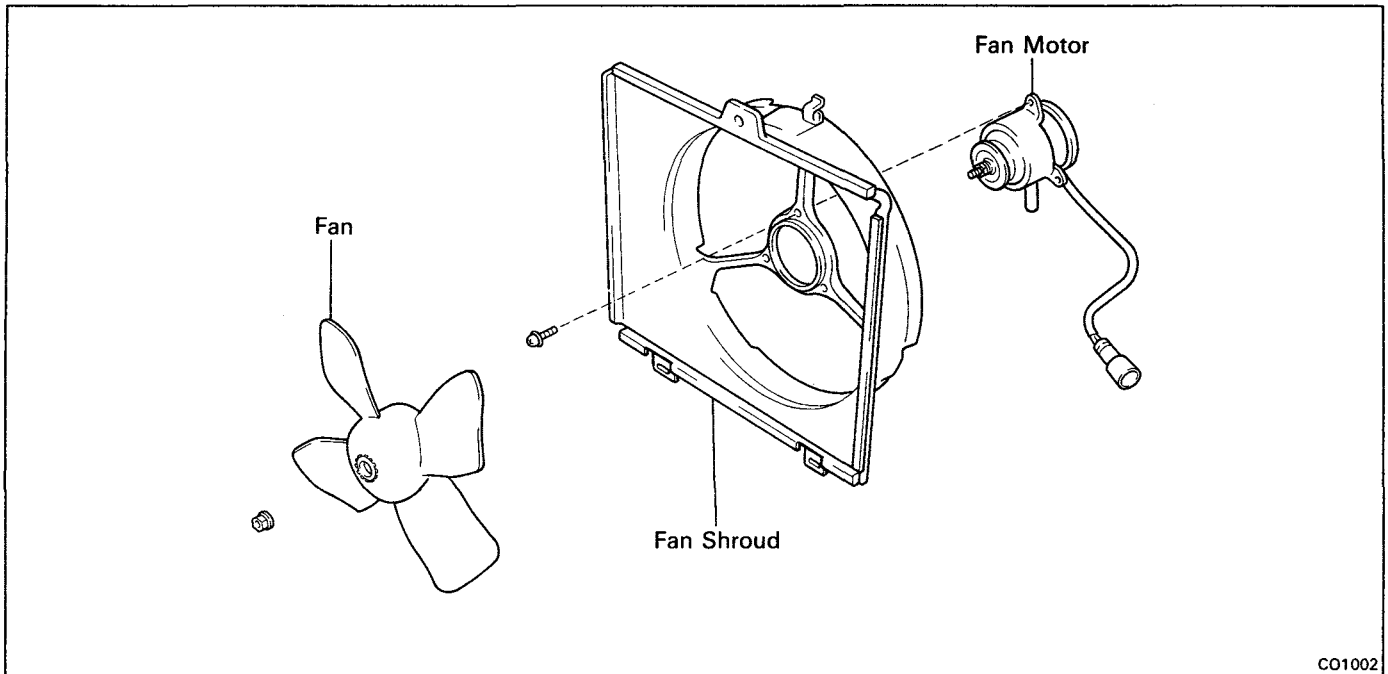

### DISASSEMBLY OF RADIATOR COOLING FANS

- 1. REMOVE FAN**  
Remove the nut and fan.

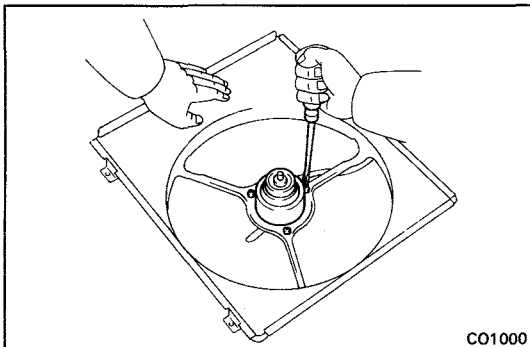

- 2. REMOVE FAN MOTOR**  
Remove the three screws and fan motor.

### ASSEMBLY OF RADIATOR COOLING FANS

- 1. INSTALL FAN MOTOR**
- 2. INSTALL FAN**

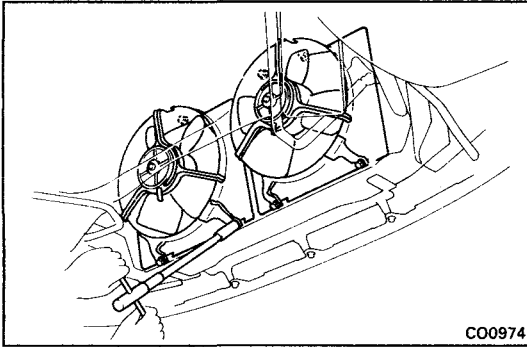

## INSTALLATION OF RADIATOR COOLING FANS

(See page CO-25)

### 1. INSTALL RADIATOR COOLING FANS

Install the cooling fan with the three bolts. Install the two cooling fans.

### 2. CONNECT RADIATOR COOLING FAN CONNECTORS

### 3. CONNECT UPPER RADIATOR SUPPORT SEAL (See step 10 on page CO-20)

### 4. CONNECT FRONT LUGGAGE UNDER COVERS

### 5. CONNECT CABLE TO NEGATIVE TERMINAL OF BATTERY

# Radiator Cooling Fan (w/o A/C) SYSTEM CIRCUIT

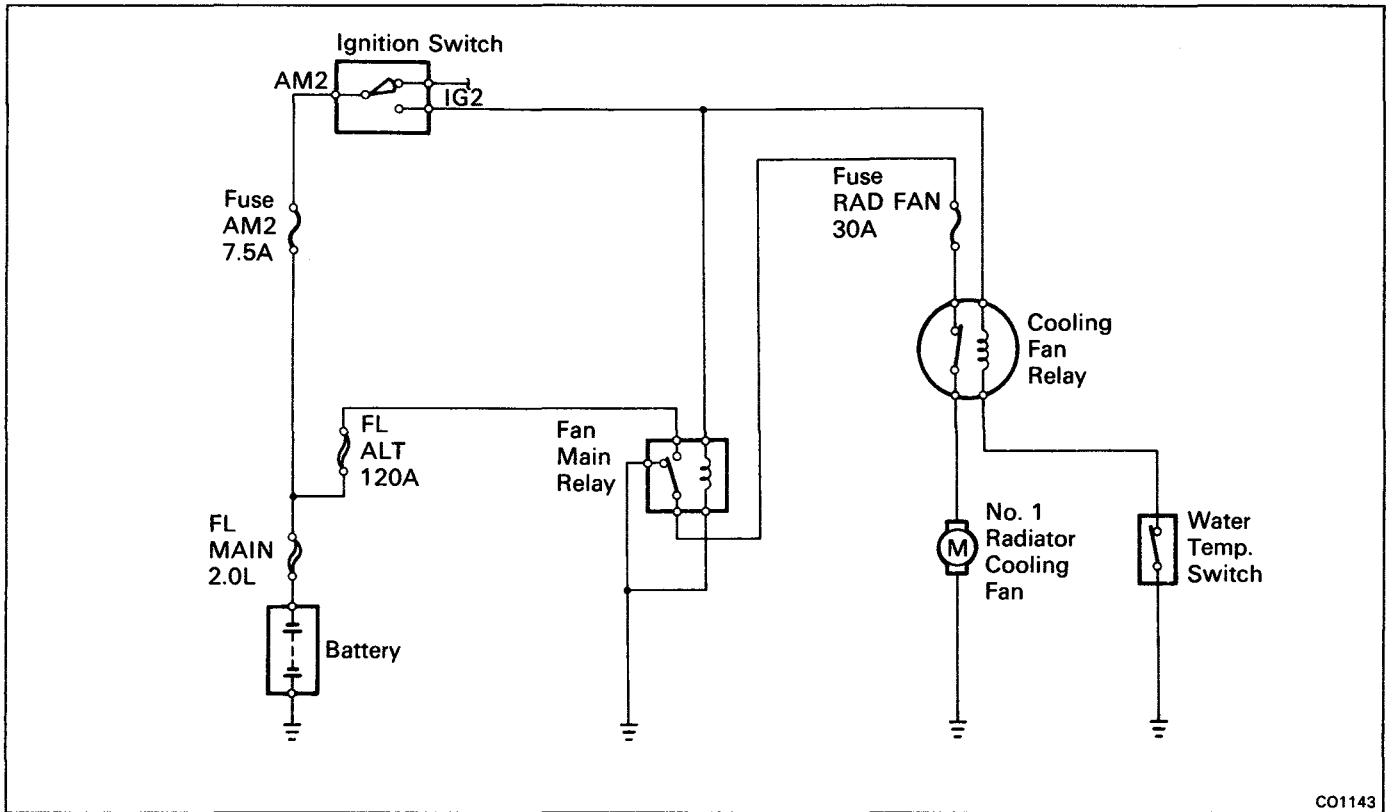

CO1143

## LOCATION OF RADIATOR COOLING FAN COMPONENTS

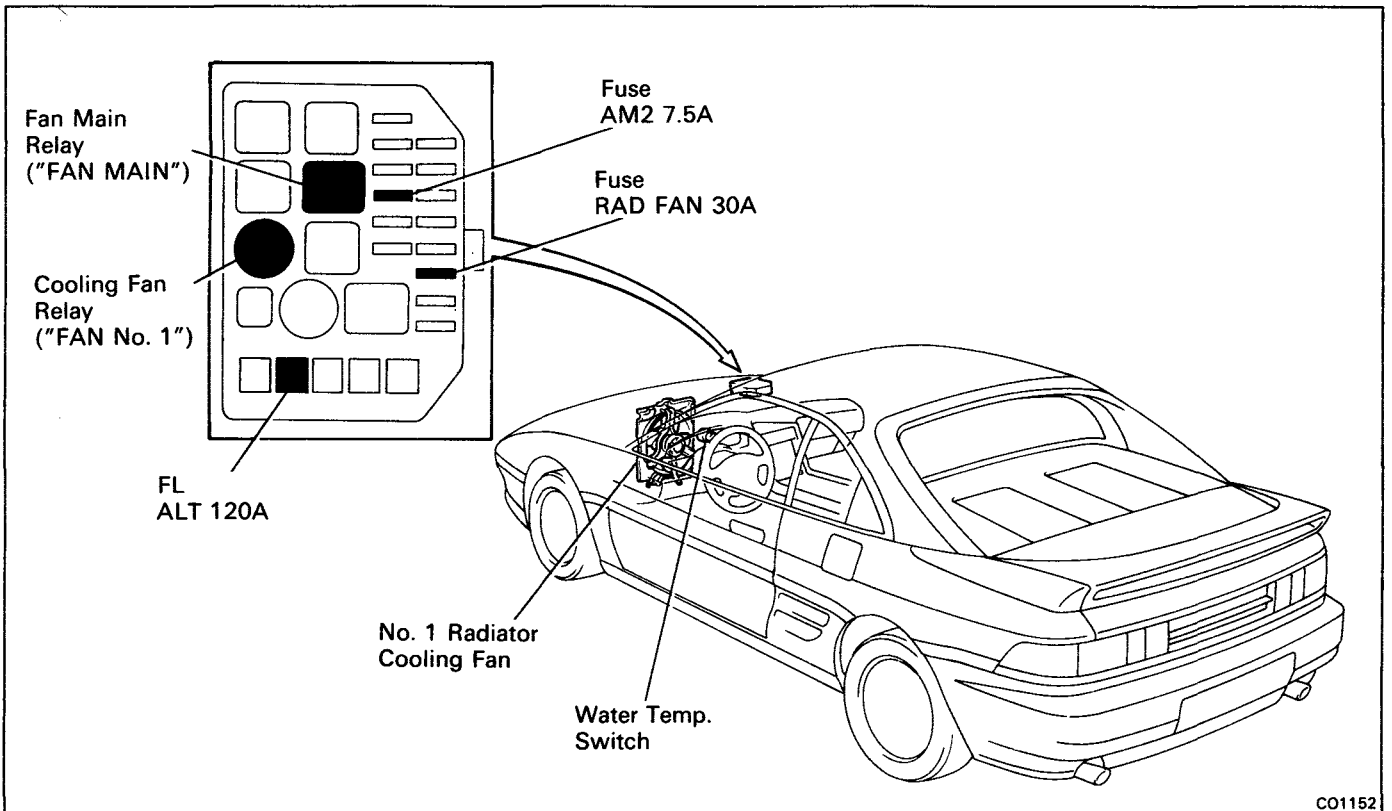

CO1152



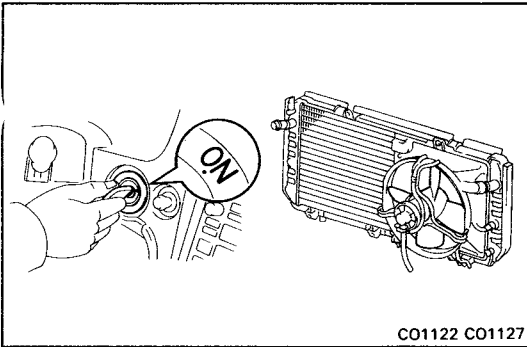

## ON-VEHICLE INSPECTION

### Low Temperature (Below 83°C (181°F))

#### 1. TURN IGNITION SWITCH "ON"

Check that the cooling fan stops.

If not, check the cooling fan relays and water temperature switch, and check for a separated connector or severed wire between the cooling fan relay and water temperature switch.

#### 2. DISCONNECT WATER TEMPERATURE SWITCH CONNECTOR

Check that the cooling fan rotates.

If not, check the fan main relay, cooling fan relays, cooling fan and fuses, and check for a short circuit between the cooling fan relay and water temperature switch.

#### 3. CONNECT WATER TEMPERATURE SWITCH CONNECTOR

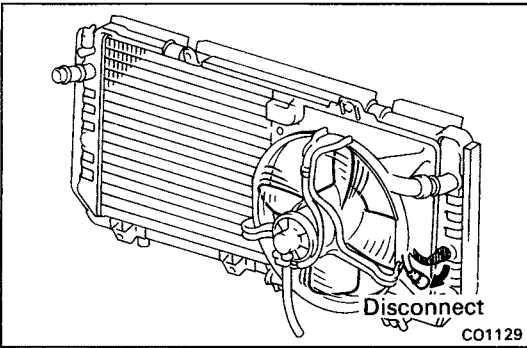

### High Temperature (Above 93°C (199°F))

#### 4. START ENGINE

(a) Raise coolant temperature to above 93°C (199°F).

(b) Check that the cooling fan rotates.

If not, replace the water temperature switch.

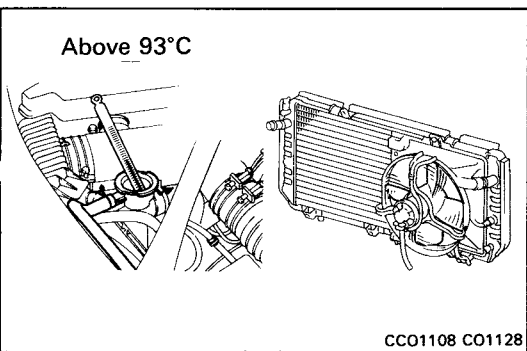

## INSPECTION OF RADIATOR COOLING FAN COMPONENTS

#### 1. INSPECT FAN MAIN RELAY ("FAN MAIN") (See page CH-18)

Check the relay in the same way as the Ignition Main Relay.

#### 2. INSPECT NO.1 COOLING FAN RELAY ("FAN NO.1") (See page CO-23)

#### 3. INSPECT RADIATOR WATER TEMPERATURE SWITCH

(a) Using an ohmmeter, check that there is no continuity between the terminals when the coolant temperature is above 93°C (199°F).

(b) Using an ohmmeter, check that there is continuity between the terminals when the coolant temperature is below 83°C (181°F).

If continuity is not as specified, replace the switch.

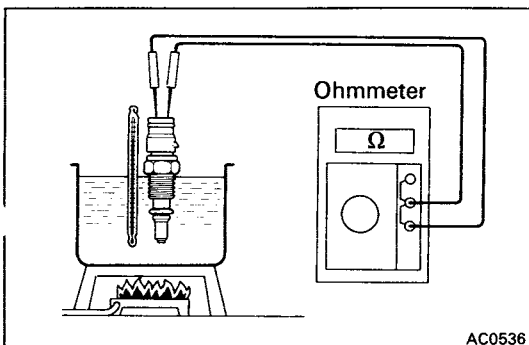

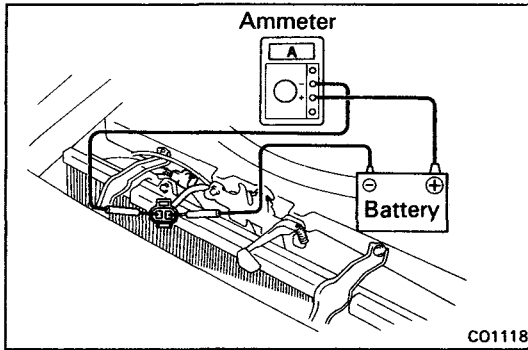

#### 4. INSPECT NO. 1 RADIATOR COOLING FAN

- (a) Connect battery and ammeter to the cooling fan connector.
- (b) Check that the cooling fan rotates smoothly, and check the reading on the ammeter.

Standard amperage: M/T 5.8 – 7.4 A  
A/T 8.8 – 10.8 A

### REMOVAL OF RADIATOR COOLING FAN

REMOVE NO.1 RADIATOR COOLING FAN  
(See page CO-25)

### DISASSEMBLY AND ASSEMBLY OF RADIATOR COOLING FAN

(See page CO-26)

### INSTALLATION OF RADIATOR COOLING FAN

INSTALL NO. 1 RADIATOR COOLING FAN  
(See page CO-27)

# Engine Compartment Cooling Fan (3S-GTE)

## SYSTEM CIRCUIT

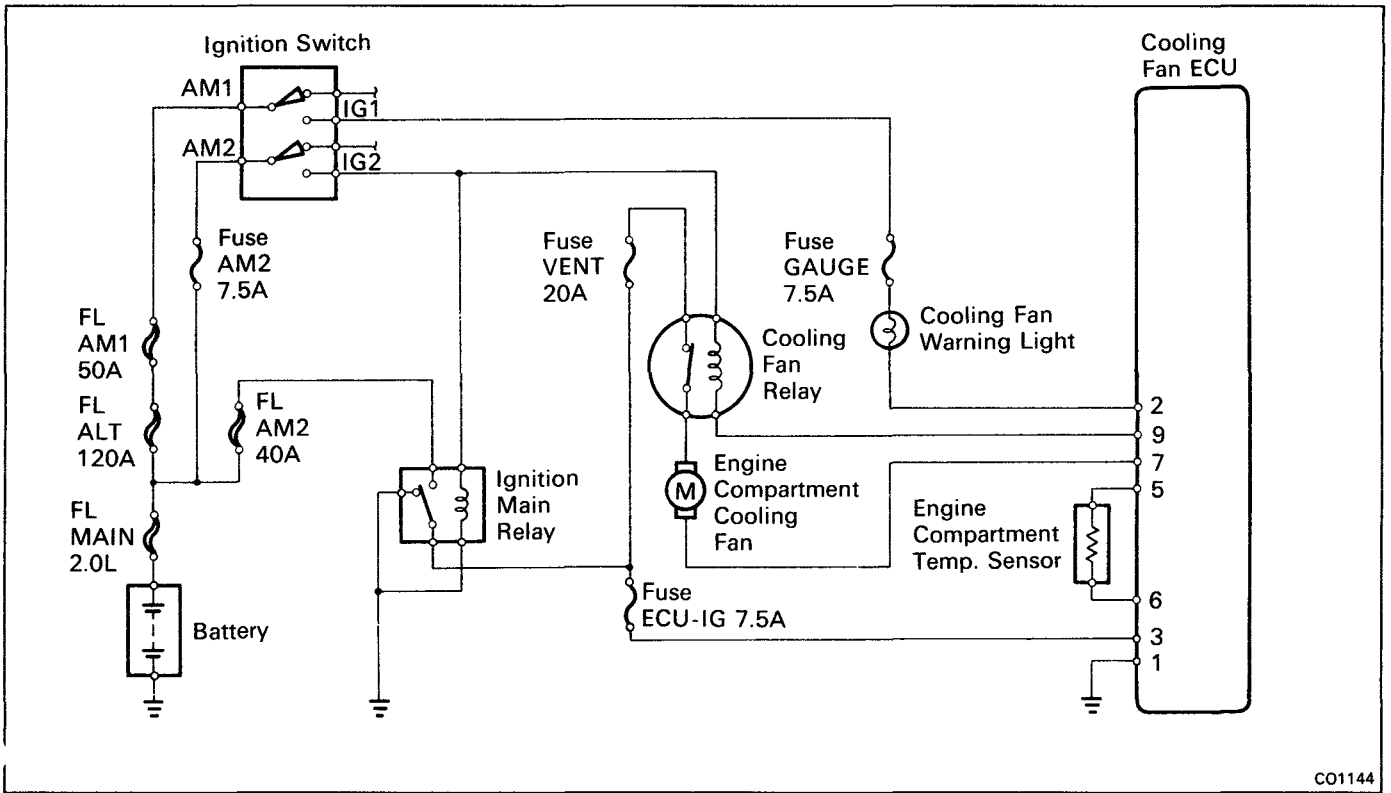

CO1144

## LOCATION OF ENGINE COMPARTMENT COOLING FAN COMPONENTS

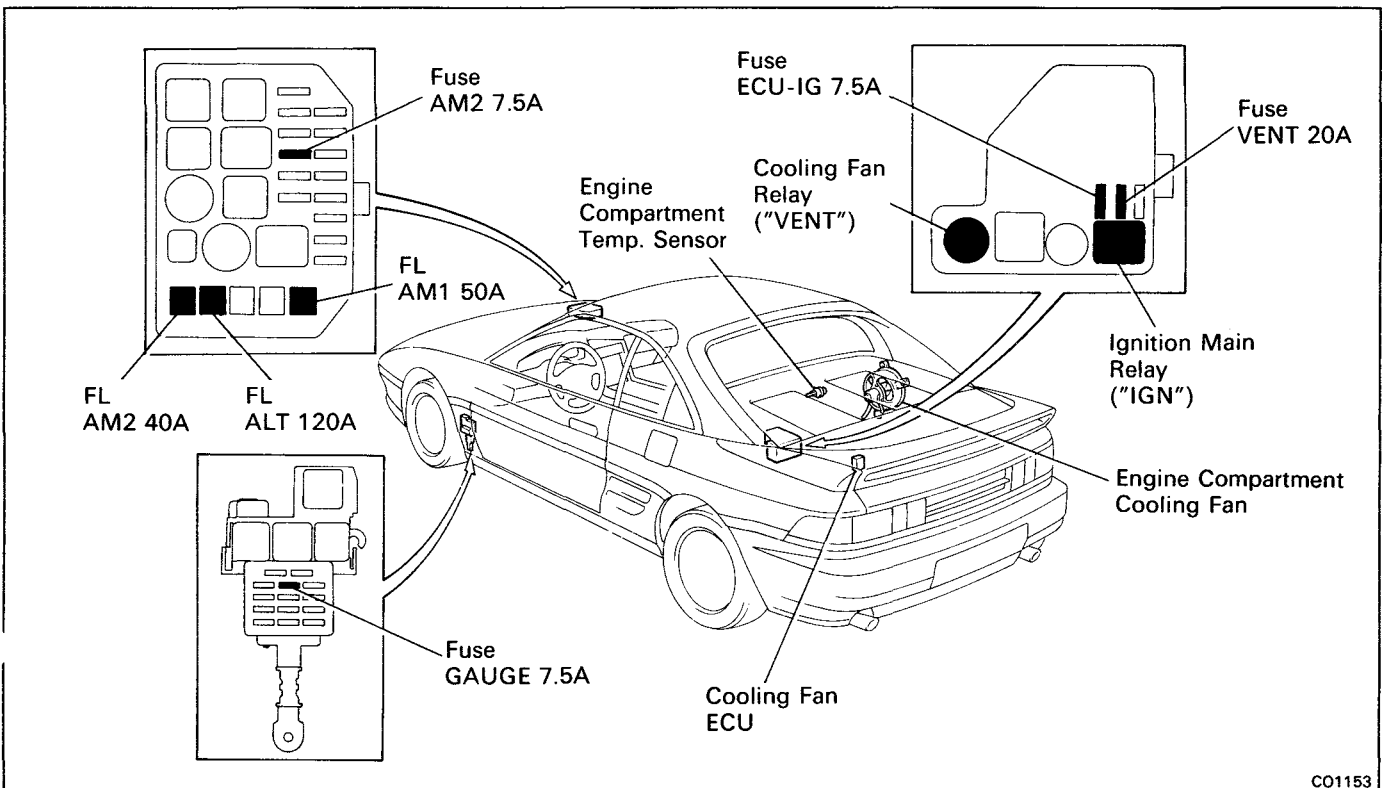

CO1153

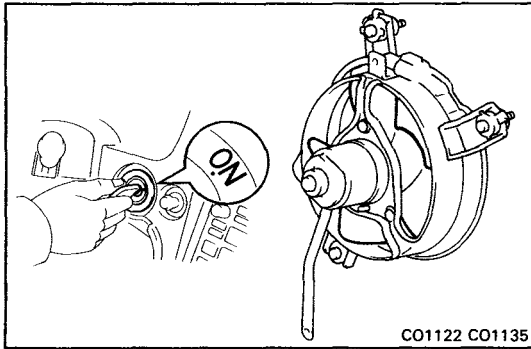

## ON-VEHICLE INSPECTION

### Low Temperature (Below 45.5°C (113.9°F))

#### 1. TURN IGNITION SWITCH "ON"

Check that the cooling fan stops.

If not, check the cooling fan relays and engine compartment temperature sensor, and check for a separated connector or severed wire between the cooling fan relay and engine compartment temperature sensor.

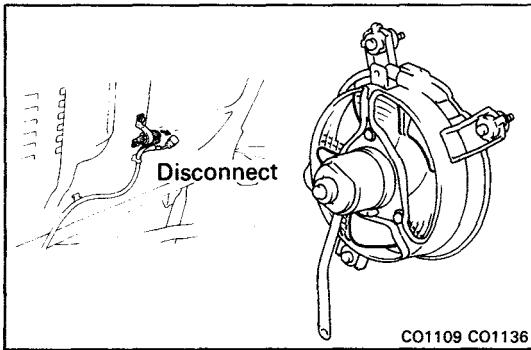

#### 2. DISCONNECT ENGINE COMPARTMENT TEMPERATURE SENSOR CONNECTOR

Check that the cooling fan rotates.

If not, check the ignition main relay, cooling fan relays, cooling fan ECU, cooling fan and fuses, and check for a short circuit between the cooling fan relay and engine compartment temperature sensor.

#### 3. CONNECT ENGINE COMPARTMENT TEMPERATURE SENSOR CONNECTOR

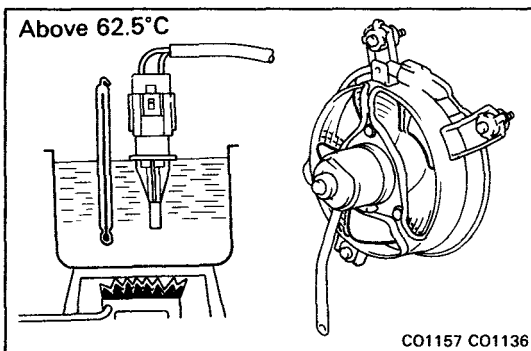

### High Temperature (Above 62.5°C (144.5°F))

#### 4. START ENGINE

(a) Raise coolant temperature to above 62.5°C (144.5°F).

(b) Check that the cooling fan rotates.

If not, replace the engine compartment temperature sensor.

Wiring Harness Side

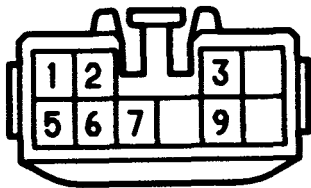

AE-10-1

### INSPECTION OF ENGINE COMPARTMENT COOLING FAN COMPONENTS

1. INSPECT COOLING FAN ECU FOR CIRCUIT

Disconnect the cooling fan ECU connector, and check the connector on the wiring harness side as shown in the chart.

Check for	Tester connection	Condition	Specified value
Continuity	1 – Ground	–	Continuity
Voltage	2 – Ground	Ignition switch ON	Battery voltage
Voltage	3 – Ground	Ignition switch ON	Battery voltage
Resistance	5 – 6	Coolant temp.	20°C (68°F) Approx. 2.45 kΩ
			57.5°C (135.5°F) Approx. 0.63 kΩ
			80°C (176°F) Approx. 0.32 kΩ
Voltage	7 – Ground	Ignition switch ON	Battery voltage
Continuity	9 – Ground	Ignition switch ON	Battery voltage

2. INSPECT IGNITION MAIN RELAY ("IGN")  
 (See page CH-18)

3. INSPECT COOLING FAN MAIN RELAY ("VENT")  
 (See page CO-23)

Check the relay the same way as for the No.1 Cooling Fan Relay.

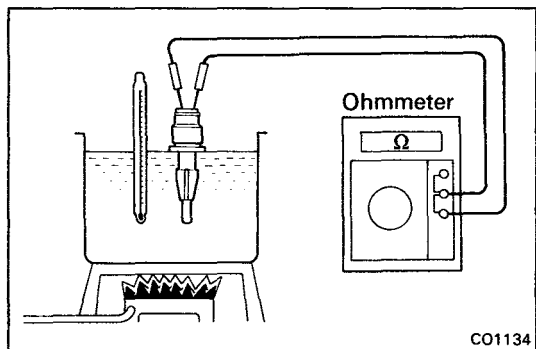

CO1134

4. INSPECT ENGINE COMPARTMENT TEMPERATURE SENSOR

Using an ohmmeter, measure the resistance between the terminals.

Resistance:

- Approx. 2.45 kΩ at 20°C (68°F)
- Approx. 0.63 kΩ at 57.5°C (135.5°F)
- Approx. 0.32 kΩ at 80°C (176°F)

If resistance is not as specified, replace the sensor.

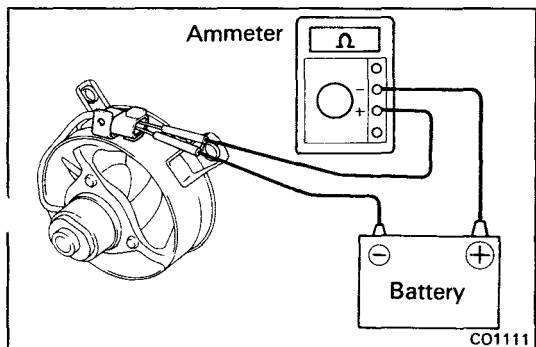

CO1111

5. INSPECT ENGINE COMPARTMENT COOLING FAN

- (a) Connect battery and ammeter to the cooling fan connector.
- (b) Check that the cooling fan rotates smoothly, and check the reading on the ammeter.

Standard amperage: 3.1 – 4.3 A

## REMOVAL OF ENGINE COMPARTMENT COOLING FAN

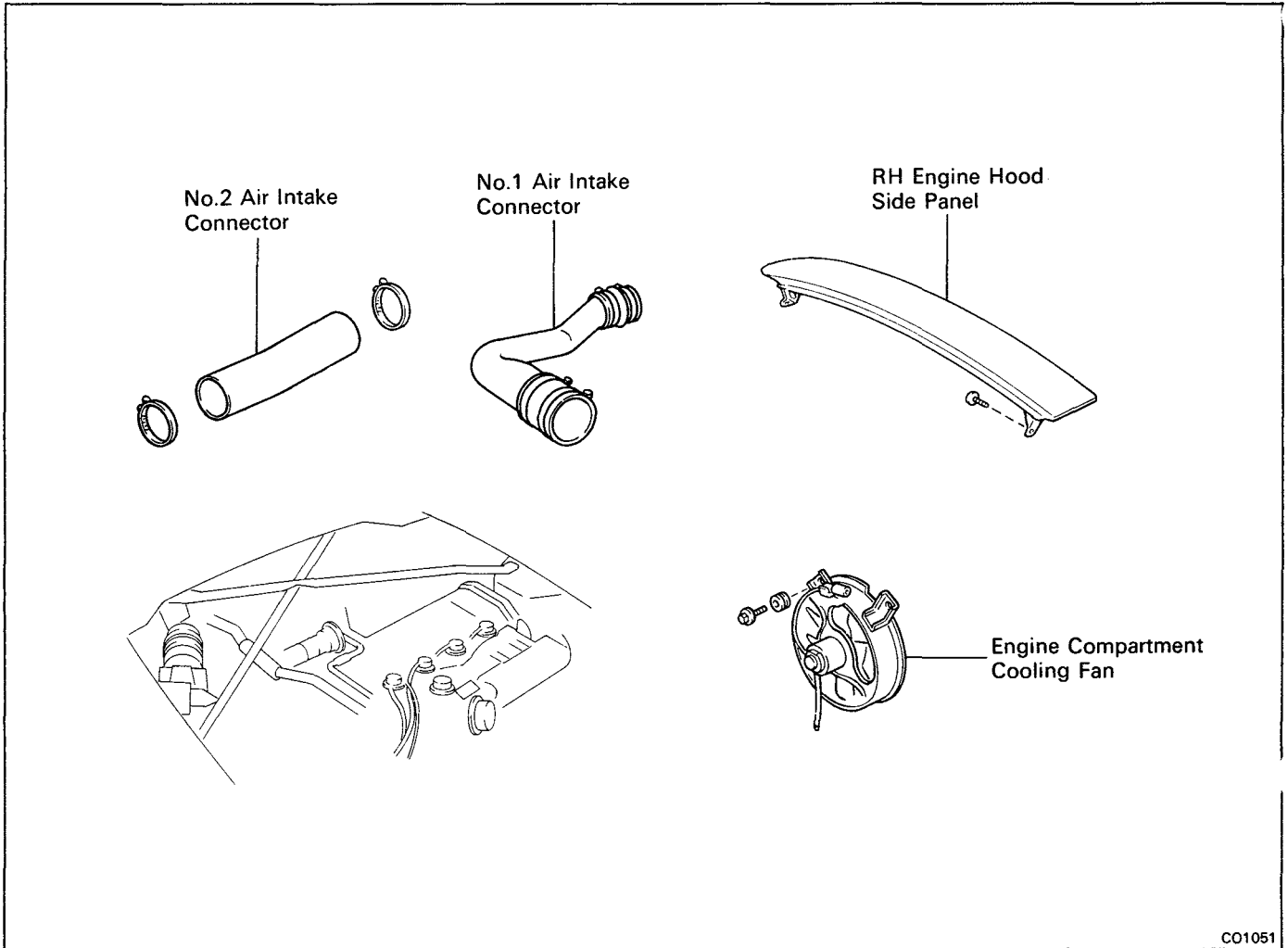

CO1051

### 1. DISCONNECT CABLE FROM NEGATIVE TERMINAL OF BATTERY

**CAUTION:** Work must be started after approx. 20 seconds or longer from the time the ignition switch is turned to the "LOCK" position and the negative (-) terminal cable is disconnected from the battery.

### 2. REMOVE RH ENGINE HOOD SIDE PANEL

### 3. REMOVE NO.1 AND NO.2 AIR INTAKE CONNECTORS (See steps 4 and 5 on page TC-20)

### 4. DISCONNECT ENGINE COMPARTMENT COOLING FAN CONNECTOR

### 5. REMOVE ENGINE COMPARTMENT COOLING FAN

Loosen the three bolts, and remove the cooling fan.

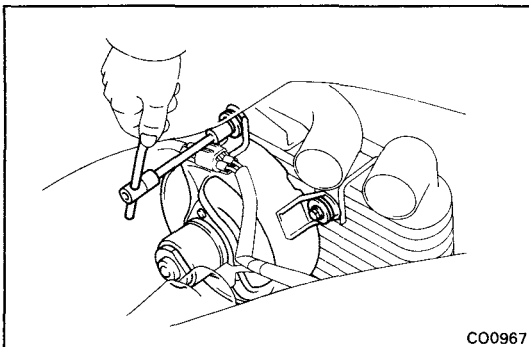

CO0967

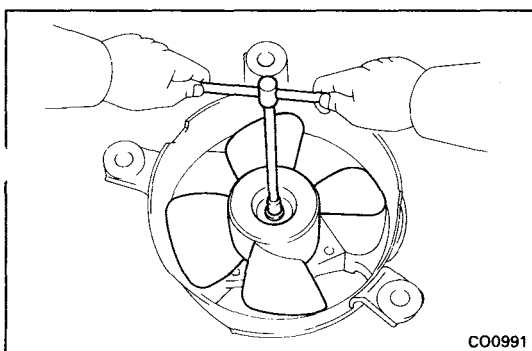
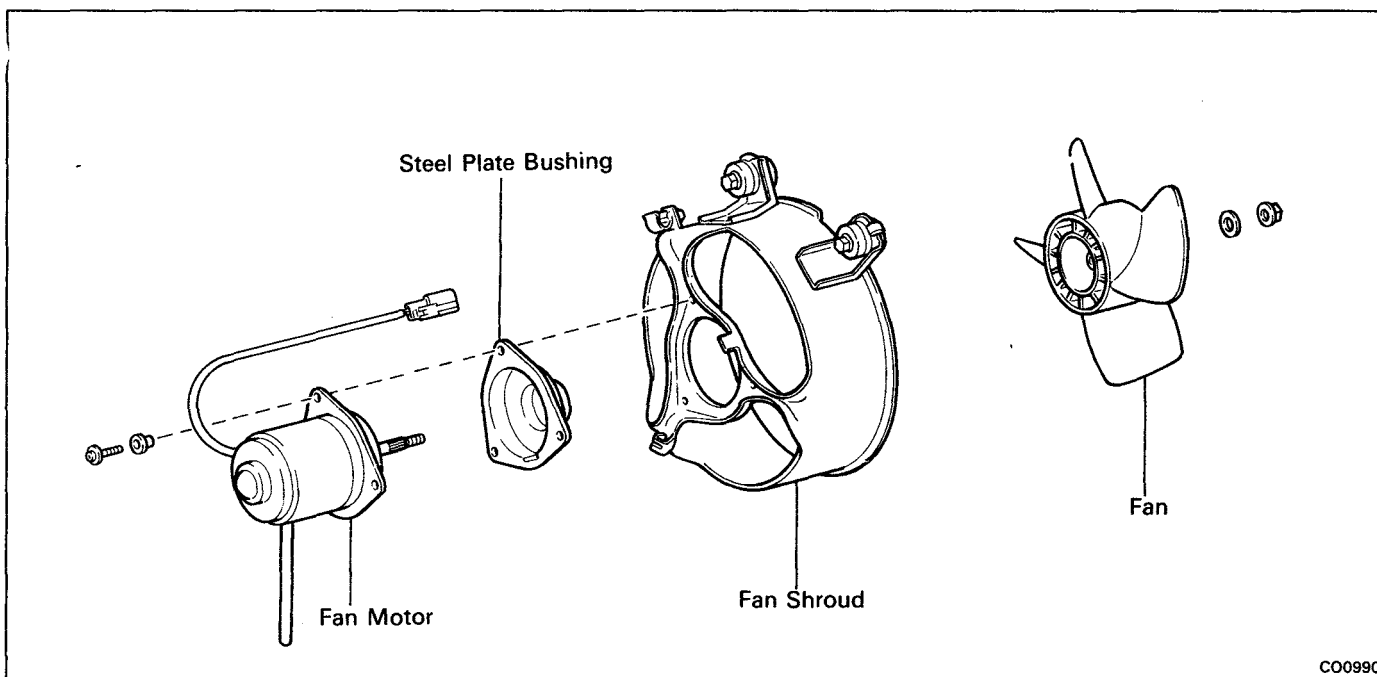
**COMPONENTS****DISASSEMBLY OF ENGINE COMPARTMENT COOLING FAN****1. REMOVE FAN**

Remove the nut and fan.

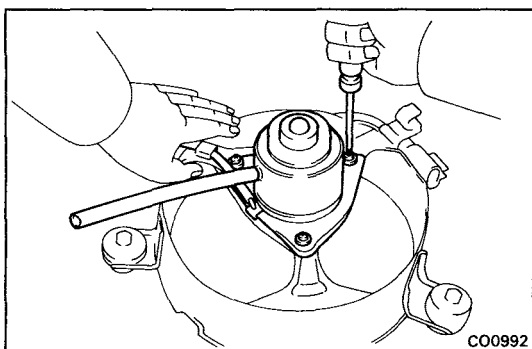
**2. REMOVE FAN MOTOR**

Remove the three screws and fan motor.

**ASSEMBLY OF ENGINE COMPARTMENT COOLING FAN****1. INSTALL FAN MOTOR****2. INSTALL FAN**

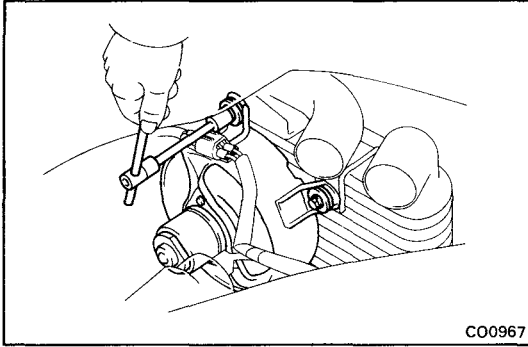

## INSTALLATION OF ENGINE COMPARTMENT COOLING FAN

(See page CO-34)

1. **INSTALL ENGINE COMPARTMENT COOLING FAN**  
Install the cooling fan with the three bolts.
2. **CONNECT ENGINE COMPARTMENT COOLING FAN CONNECTOR**
3. **INSTALL NO.1 AND NO.2 AIR INTAKE CONNECTORS**  
(See steps 10 and 11 on page TC-25)
4. **INSTALL RH ENGINE HOOD SIDE PANEL**
5. **CONNECT CABLE TO NEGATIVE TERMINAL OF BATTERY**



# LUBRICATION SYSTEM

	Page
DESCRIPTION .....	LU-2
TROUBLESHOOTING .....	LU-5
OIL PRESSURE CHECK .....	LU-6
REPLACEMENT OF ENGINE OIL AND OIL FILTER .....	LU-7
OIL PUMP .....	LU-9
OIL COOLER .....	LU-16
OIL NOZZLES .....	LU-23

DESCRIPTION

A fully pressurized, fully filtered lubrication system has been adopted for this engine.

5S-FE

3S-GE

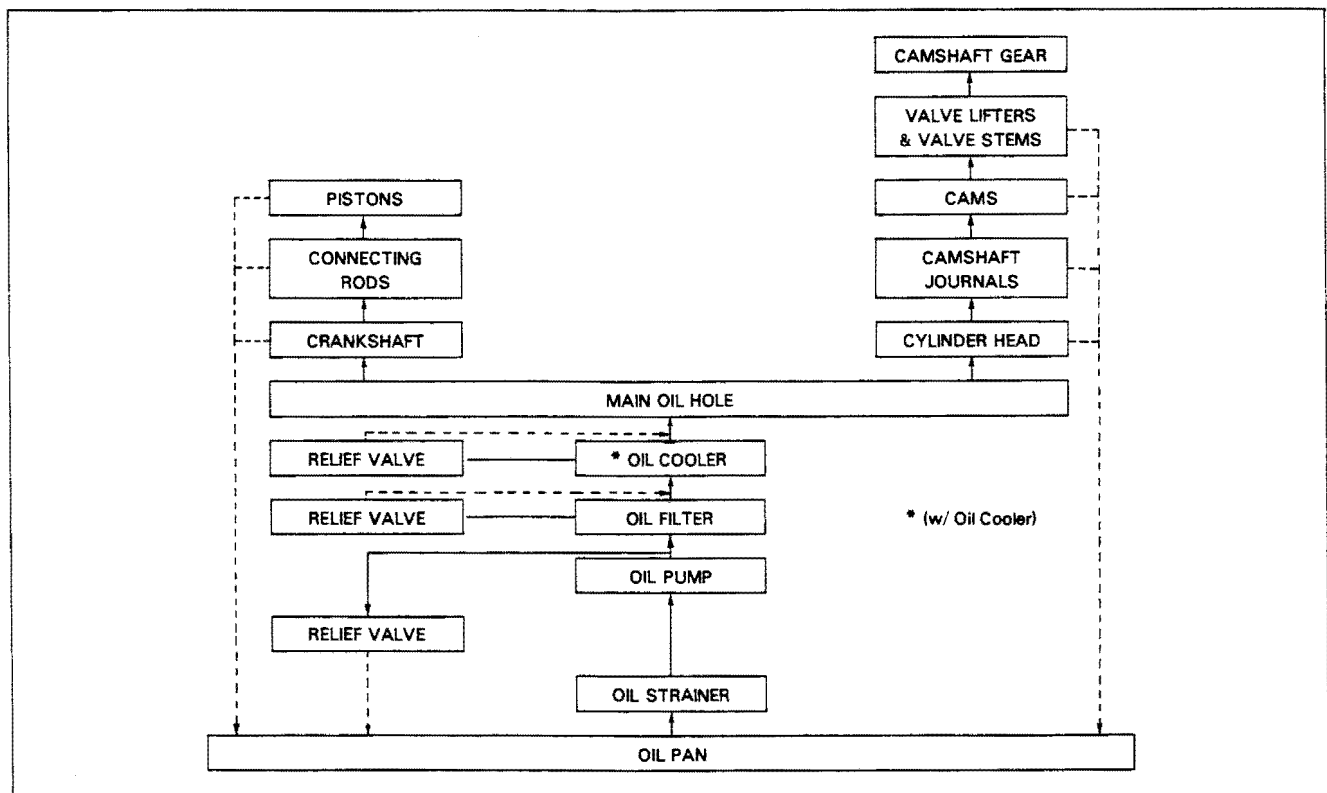
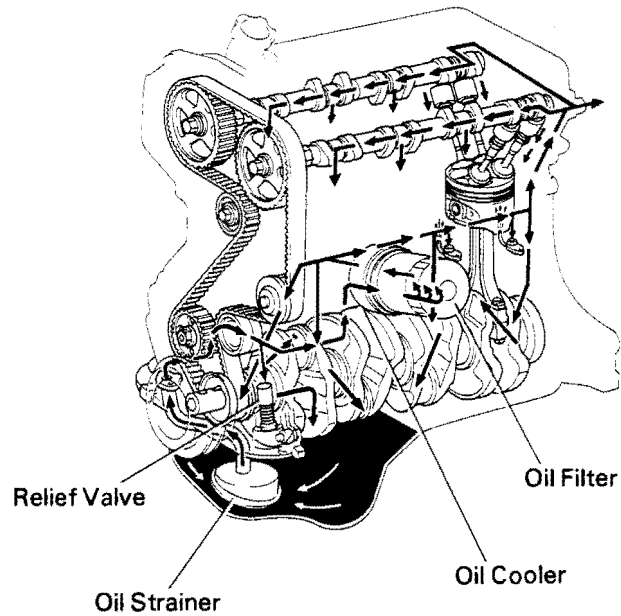
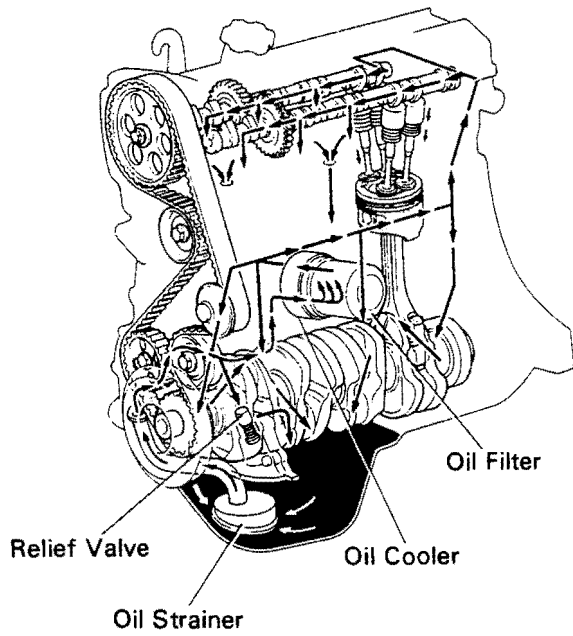

3S-GTE

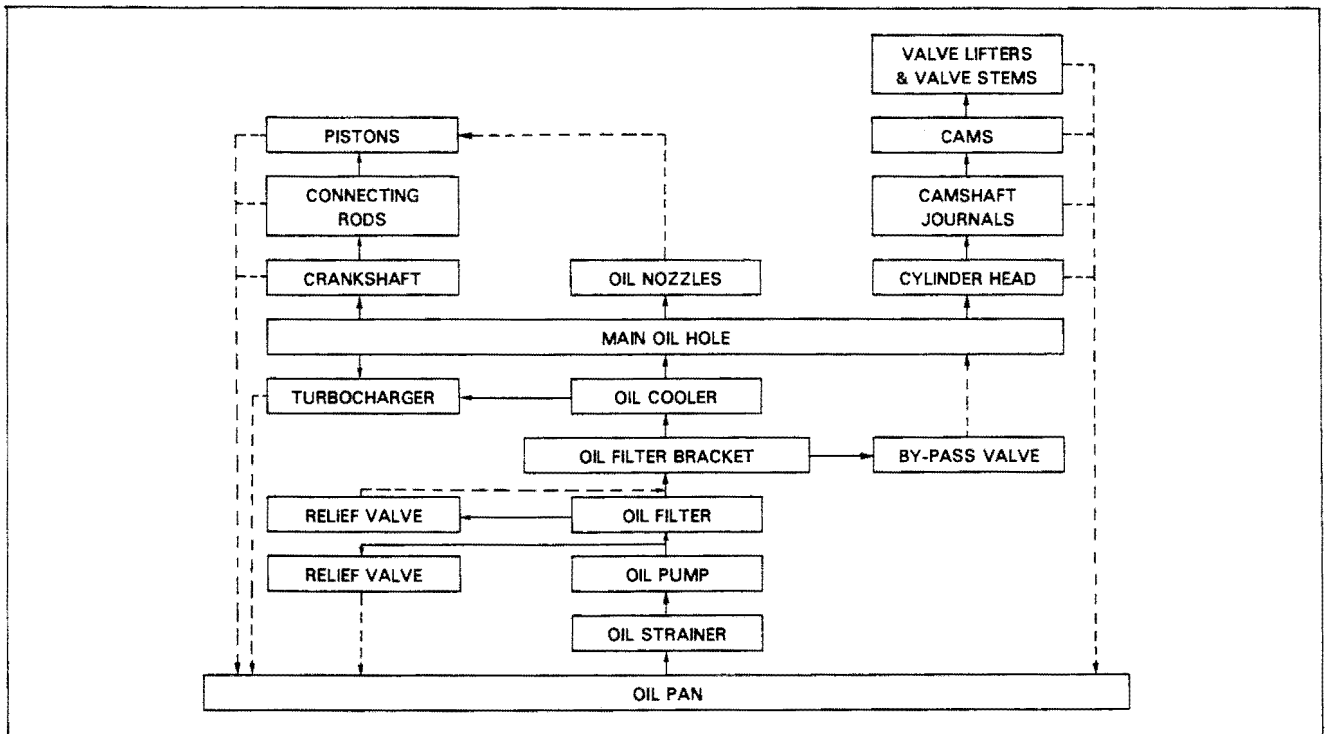
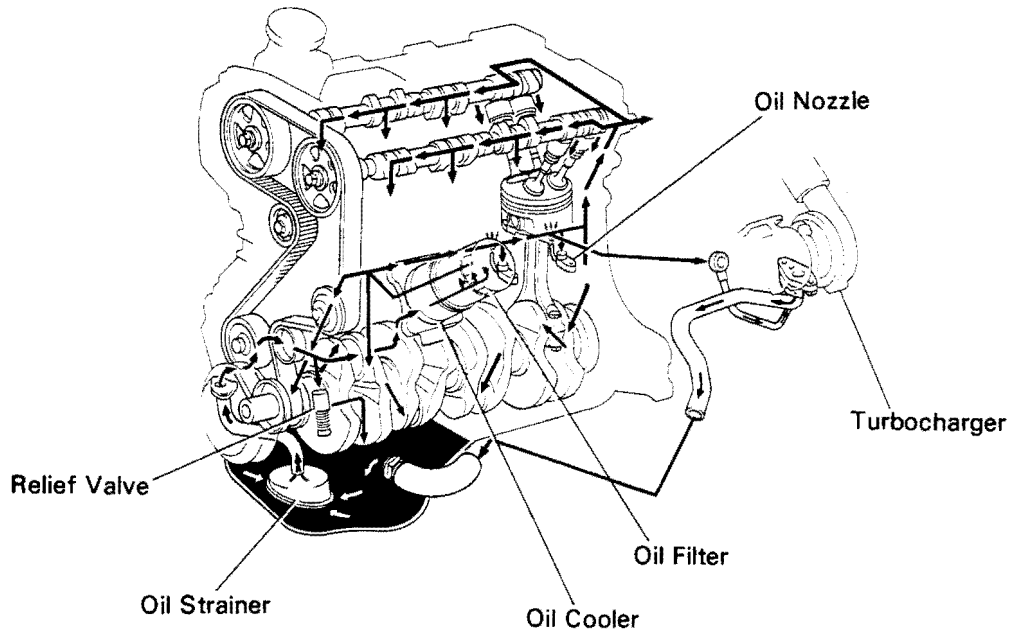

A pressure feeding lubrication system has been adopted to supply oil to the moving parts of this engine. The lubrication system consists of an oil pan, oil pump, oil filter and other external parts which supply oil to the moving parts in the engine block. The oil circuit is shown in the illustration at the top of the previous page. Oil from the oil pan is pumped up by the oil pump. After it passes through the oil filter, it is fed through the various oil holes in the crankshaft and cylinder block. After passing through the cylinder block and performing its lubricating function, the oil is returned by gravity to the oil pan. A dipstick on the center left side of the cylinder block is provided to check the oil level.

#### **OIL PUMP**

The oil pump pumps up oil from the oil pan and sends it under pressure to the various parts of the engine. An oil strainer is mounted in front of the inlet to the oil pump. The oil pump itself is a trochoid type pump, inside of which there is a drive rotor and a driven rotor. When the driven rotor rotates, the driven rotor rotates in the same direction, and since the axis of the drive rotor shaft is different from the center of the driven rotor, the space between the two rotors is changed as they rotate. Oil is drawn in when the space is wide and is discharged when the space is narrow.

#### **OIL PRESSURE REGULATOR**

At high engine speeds, the engine oil supplied by the oil pump exceeds the capacity of the engine to utilize it. For that reason, the oil pressure regulator works to prevent an oversupply of oil. During normal oil supply, a coil spring and valve keep the by-pass closed, but when too much oil is being fed, the pressure becomes extremely high, overpowering the force of the spring and opening the valves. This allows the excess oil to flow through the valve and return to the oil pan.

#### **OIL FILTER**

The oil filter is a full flow type filter with a built-in paper filter element. Particles of metal from wear, airborne dirt, carbon and other impurities can get into the oil during use and could cause accelerated wear or seizing if allowed to circulate through the engine. The oil filter, integrated into the oil line, removes these impurities as the oil passes through it. The filter is mounted outside the engine to simplify replacement of the filter element. A relief valve is also included ahead of the filter element to relieve the high oil pressure in case that filter element becomes clogged with impurities. The relief valve opens when the oil pressure overpowers the force of the spring. Oil passing through the relief valve by-passes the oil filter and flows directly into the main oil hole in the engine.

## TROUBLESHOOTING

Problem	Possible cause	Remedy	Page
Oil leakage	Cylinder head, cylinder block or oil pump body damaged or cracked	Repair as necessary	EM-165 LU-13
	Oil seal faulty	Replace oil seal	
	Gasket faulty	Replace gasket	
Low oil pressure	Oil leakage	Repair as necessary	LU-9 LU-9 LU-7 EM-148, 174 EM-148, 174 LU-7
	Relief valve faulty	Repair relief valve	
	Oil pump faulty	Repair oil pump	
	Engine oil poor quality	Replace engine oil	
	Crankshaft bearing faulty	Replace bearing	
	Connecting rod bearing faulty	Replace bearing	
Oil filter clogged	Replace oil filter		
High oil pressure	Relief valve faulty	Repair relief valve	LU-9

Recommended Viscosity (SAE):

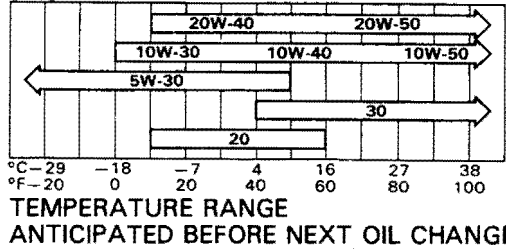

LU0310

# OIL PRESSURE CHECK

## 1. CHECK OIL QUALITY

Check the oil for deterioration, entry of water, discoloring or thinning.

If oil quality is poor, replace it.

Use the following API grade, recommended viscosity oils.

- Europe 3S-GE and Australia SE, SF, SG or better
- Europe 3S-GTE SF, SG or better
- Others SD, SE, SF, SG or better

## 2. CHECK ENGINE OIL LEVEL

The oil level should be between the "L" and "F" marks on the dipstick.

If low, check for leakage and add oil up to "F" mark.

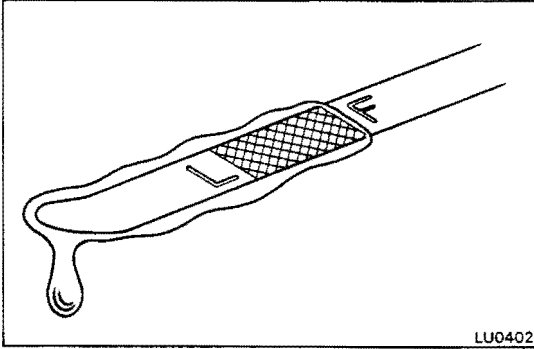

LU0402

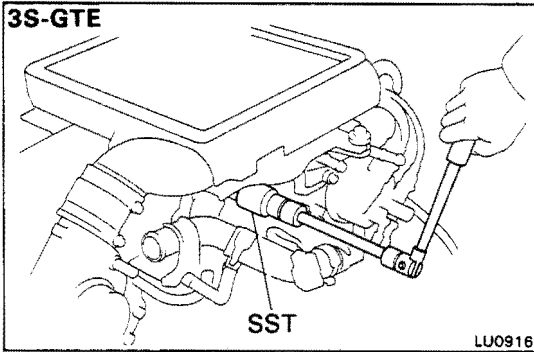

LU0916

## 3. REMOVE OIL PRESSURE SWITCH

(5S-FE, 3S-GE)  
Remove the oil pressure switch.

(3S-GTE)  
Using SST, remove the oil pressure switch.  
SST 09816-30010

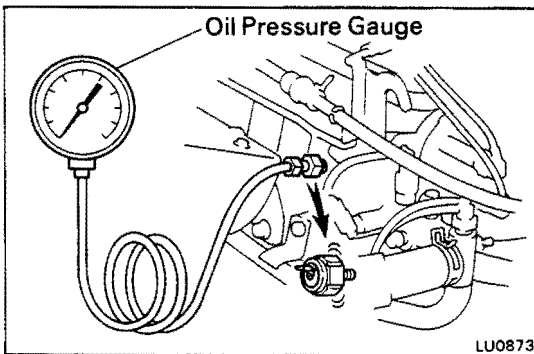

LU0873

## 4. INSTALL OIL PRESSURE GAUGE

## 5. WARM UP ENGINE

Allow the engine to warm up to normal operating temperature.

## 6. CHECK OIL PRESSURE

Oil pressure:

At idling	0.3 kg/cm <sup>2</sup> (4.3 psi, 29kPa) or more
At 3,000 rpm	2.5 – 5.0 kg/cm <sup>2</sup> (36 – 71 psi, 245 – 490 kPa)

## 7. REMOVE OIL PRESSURE GAUGE, AND REINSTALL OIL PRESSURE SWITCH

Apply adhesive to two or three threads of the oil pressure switch.

Adhesive: Part No. 08833-00080, THREE BOND 1344, LOCTITE 242 or equivalent

## 8. START ENGINE AND CHECK FOR LEAKS

## REPLACEMENT OF ENGINE OIL AND OIL FILTER

### NOTICE:

- Prolonged and repeated contact with mineral oil will result in the removal of natural fats from the skin, leading to dryness, irritation and dermatitis. In addition, used engine oil contains potentially harmful contaminants which may cause skin cancer.
- Care should be taken, therefore, when changing engine oil to, minimize the frequency and length of time your skin is exposed to used engine oil. Protective clothing and gloves, that cannot be penetrated by oil, should be worn. The skin should be thoroughly washed with soap and water, or use waterless hand cleaner, to remove any used engine oil. Do not use gasoline, thinners, or solvents.
- In order to preserve the environment, used oil must be disposed of only at designated disposal sites.

### 1. DRAIN ENGINE OIL

- Remove the oil filler cap.
- Remove the oil drain plug, and drain the oil into a container.

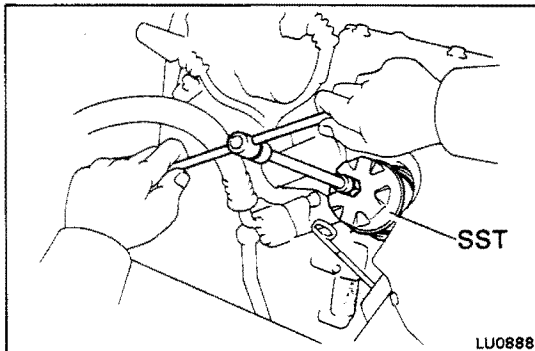

### 2. REPLACE OIL FILTER

- (3S-GTE)  
Remove the air duct from the alternator.
- Using SST, remove the oil filter.  
SST 09228-06500
- Check and clean the oil filter installation surface.
- Apply clean engine oil to the gasket of a new oil filter.

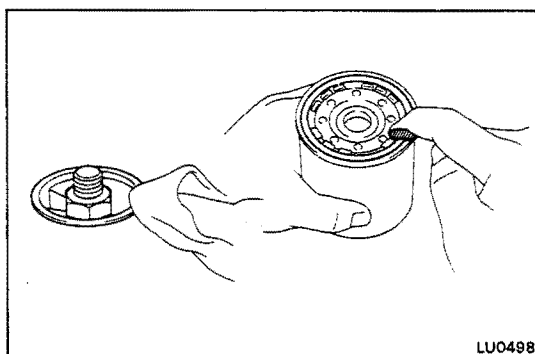

- Lightly screw the oil filter into place, and tighten it until the gasket contacts the seat.
- Using SST, tighten it an additional 3/4 turn.  
SST 09228-06500
- (3S-GTE)  
Reinstall the air duct to the alternator.

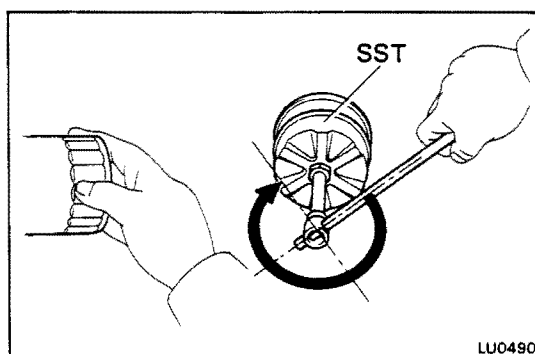

**3. FILL WITH ENGINE OIL**

(a) Clean and install the oil drain plug with a new gasket.

**Torque: 250 kg-cm (18 ft-lb, 25 N·m)**

(b) Fill with new engine oil.

**Oil grade: See page LU-6**

**Capacity:**

**5S-FE (w/ Oil cooler)**

**Drain and refill**

**w/ Oil filter change**

**4.2 liters (4.4 US qts, 3.7 Imp. qts)**

**w/o Oil filter change**

**3.8 liters (4.0 US qts, 3.3 Imp. qts)**

**Dry fill 4.6 liters (4.9 US qts, 4.0 Imp. qts)**

**5S-FE (w/o Oil cooler)**

**Drain and refill**

**w/ Oil filter change**

**4.1 liters (4.3 US qts, 3.6 Imp. qts)**

**w/o Oil filter change**

**3.7 liters (3.9 US qts, 3.3 Imp. qts)**

**Dry fill 4.5 liters (4.8 Us qts, 4.0 Imp. qts)**

**3S-GE, 3S-GTE**

**Drain and refill**

**w/ Oil filter change**

**3.9 liters (4.1 US qts, 3.4 Imp. qts)**

**w/o Oil filter change**

**3.6 liters (3.8 US qts, 3.2 Imp. qts)**

**Dry fill 4.3 liters (4.5 US qts, 3.8 Imp. qts)**

(c) Reinstall the oil filler cap.

**4. START ENGINE AND CHECK FOR LEAKS****5. RECHECK ENGINE OIL LEVEL (See page LU-6)**



# OIL PUMP

## REMOVAL OF OIL PUMP

HINT: When repairing the oil pump, the oil pan and strainer should be removed and cleaned.

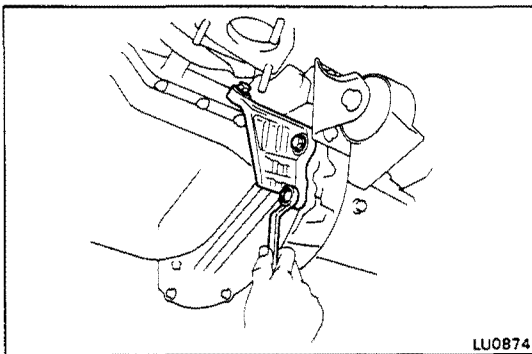
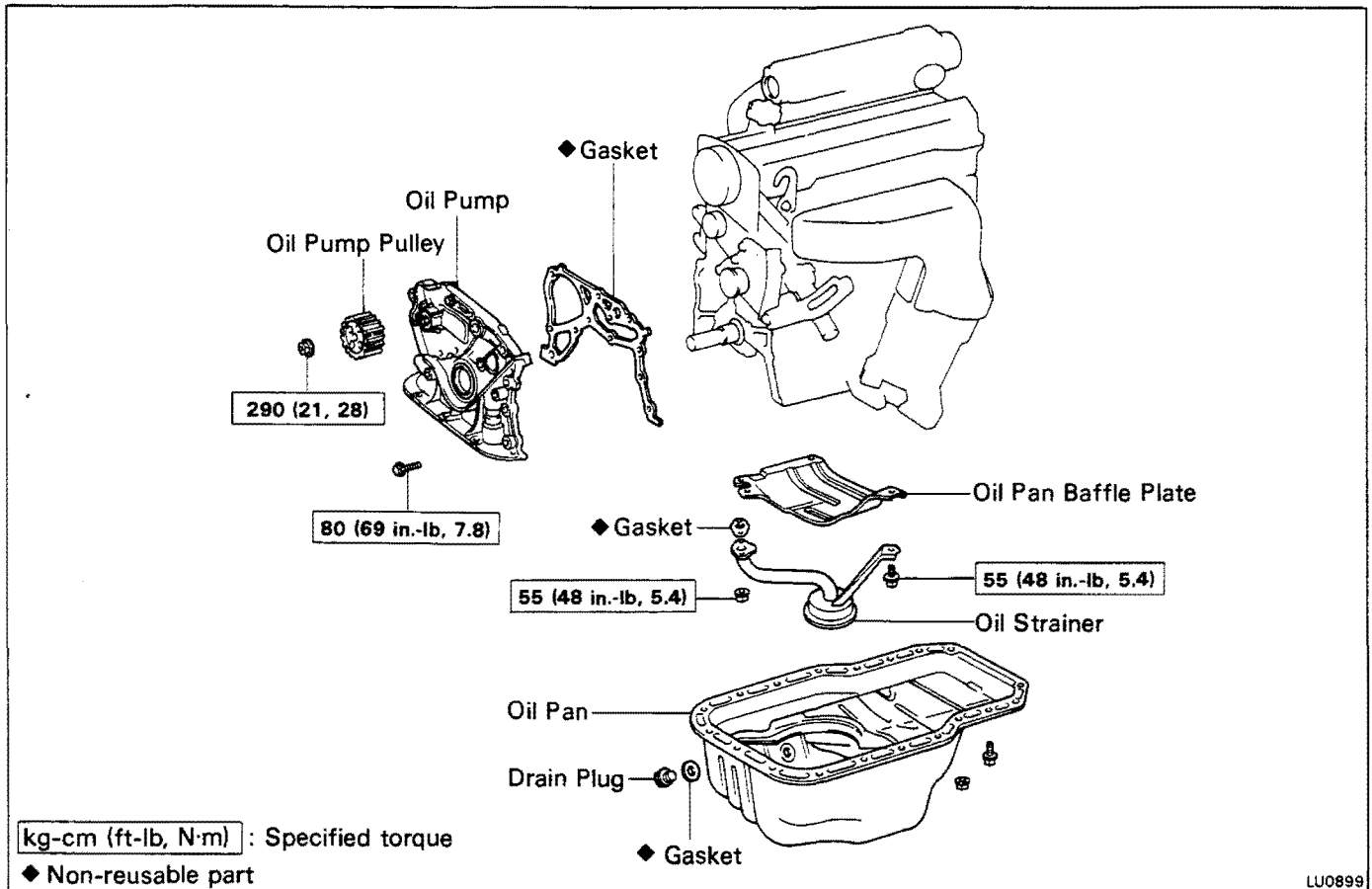

1. **DRAIN ENGINE OIL** (See page LU-7)
2. **REMOVE STIFFENER PLATE**  
Remove the two bolts and stiffener plate.

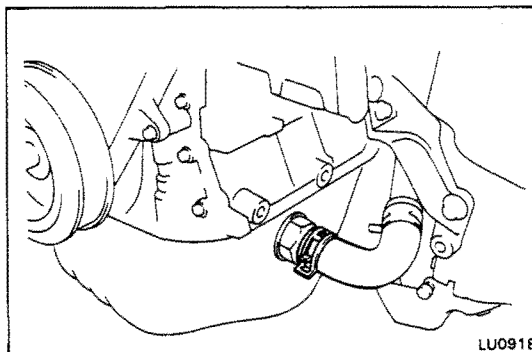

3. **(3S-GTE)**  
**DISCONNECT TURBOCHARGER OIL OUTLET HOSE FROM OIL PAN**

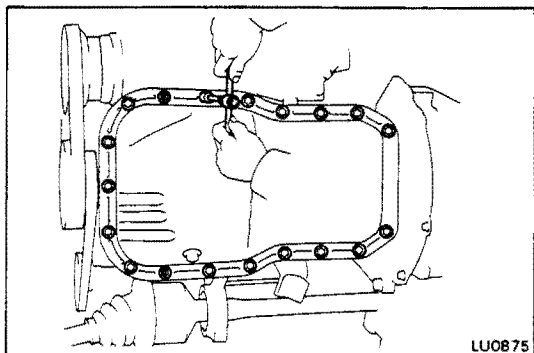

**4. REMOVE OIL PAN**

- (a) Remove the dipstick.
- (b) Remove the seventeen bolts and two nuts.

- (c) Insert the blade of SST between the cylinder block and oil pan, cut applied sealer and remove the oil pan.

SST 09032-00100

**NOTICE:**

- Do not use SST for the oil pump body side and rear oil seal retainer.
- Be careful not to damage the oil pan flange.

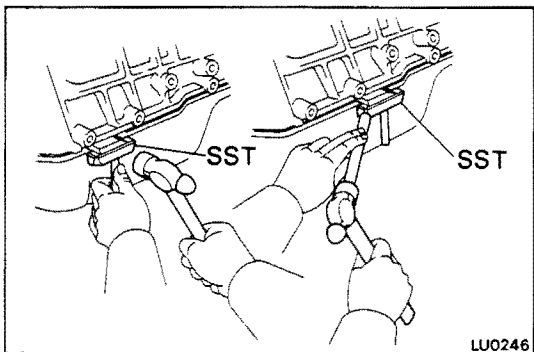

**5. REMOVE OIL STRAINER AND BAFFLE PLATE**

Remove the two bolts, two nuts, oil strainer, baffle plate and gasket.

**6. REMOVE TIMING BELT**

(5S-FE: See steps 1 to 12 on pages EM-33 to 37)

(3S-GE, 3S-GTE: See steps 1 to 17 on pages EM-45 to 49)

**7. REMOVE NO. 1 NO. 2 IDLER PULLEYS, CRANKSHAFT TIMING PULLEY AND OIL PUMP PULLEY**

(5S-FE: See steps 13 to 16 on pages EM-37, 38)

(3S-GE, 3S-GTE: See steps 18 to 21 on page EM-50)

**8. REMOVE OIL PUMP**

- (a) Remove the twelve bolts.

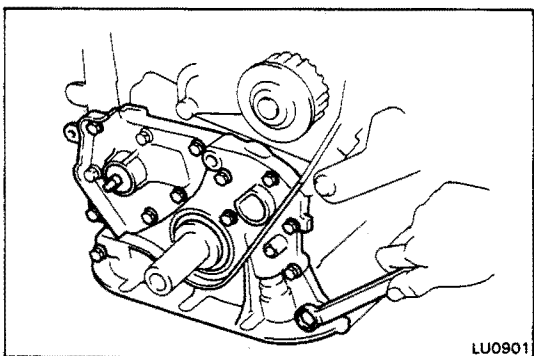
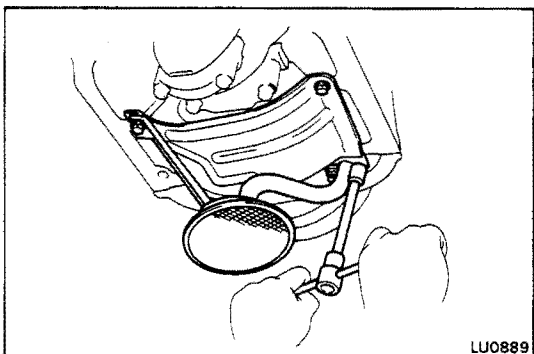

- (b) Using a plastic faced hammer, remove the oil pump by careful tapping the oil pump body.

- (c) Remove the gasket.

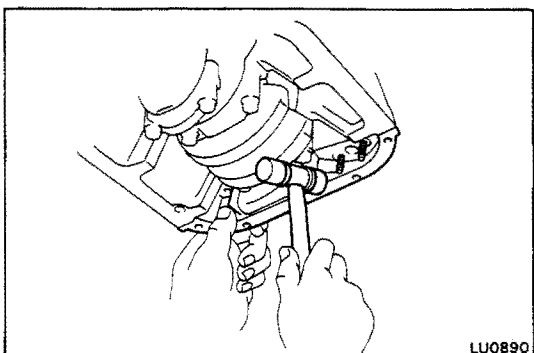

## DISASSEMBLY OF OIL PUMP

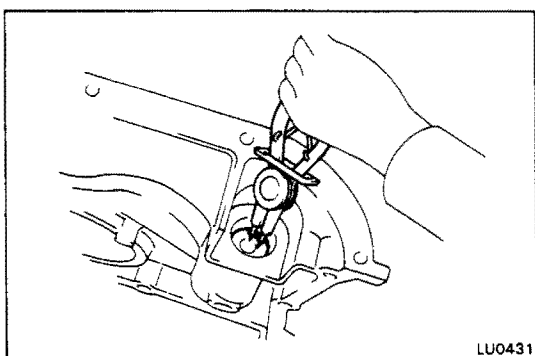
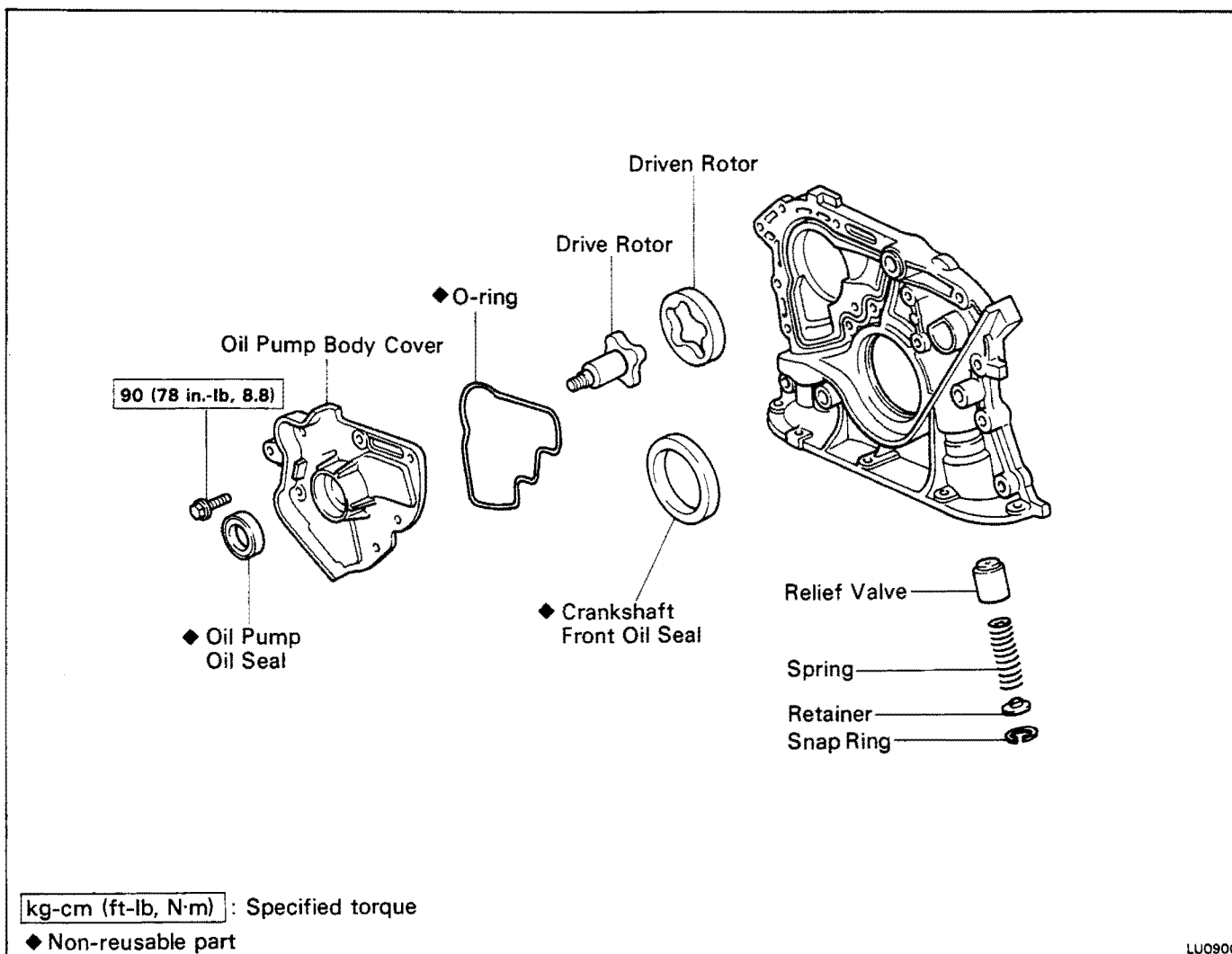

## 1. REMOVE RELIEF VALVE

- Using snap ring pliers, remove the snap ring.
- Remove the retainer, spring and relief valve.

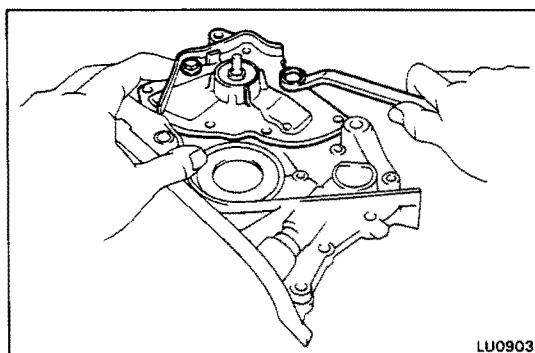

## 2. REMOVE DRIVE AND DRIVEN ROTORS

Remove the two bolts, pump body cover, O-ring, the drive and driven rotors.

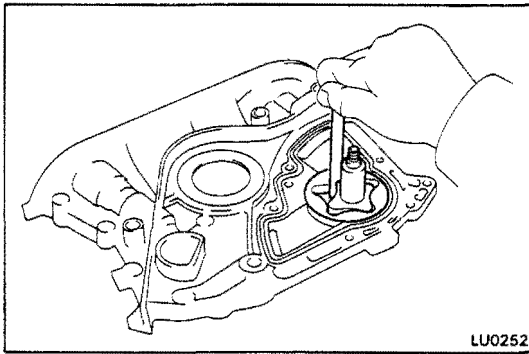

LU0252

## INSPECTION OF OIL PUMP

### 1. INSPECT RELIEF VALVE

Coat the valve with engine oil and check that it falls smoothly into the valve hole by its own weight.

If it doesn't, replace the relief valve. If necessary, replace the oil pump assembly.

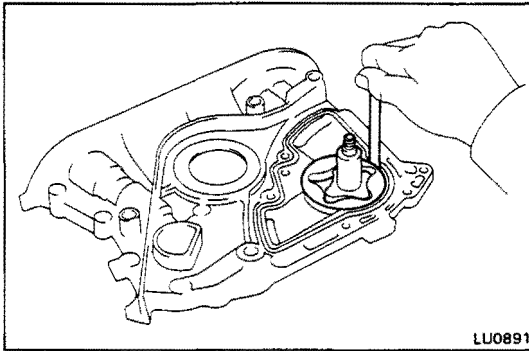

LU0891

### 2. INSPECT DRIVE AND DRIVEN ROTORS

#### A. Inspect rotor body clearance

Using a feeler gauge, measure the clearance between the driven rotor and body.

**Standard body clearance:** 0.10 – 0.16 mm  
(0.0039 – 0.0063 in.)

**Maximum body clearance:** 0.20 mm (0.0079 in.)

If the body clearance is greater than maximum, replace the rotors as a set. If necessary, replace the oil pump assembly.

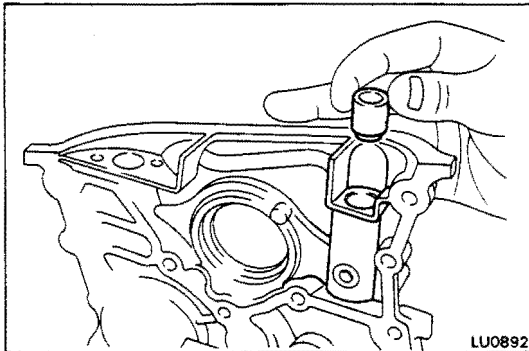

LU0892

#### B. Inspect rotor tip clearance

Using a feeler gauge, measure the clearance between the drive and driven rotors.

**Standard tip clearance:** 0.04 – 0.16 mm  
(0.0016 – 0.0063 in.)

**Maximum tip clearance:** 0.20 mm (0.0079 in.)

If the tip clearance is greater than maximum, replace the rotors as a set.

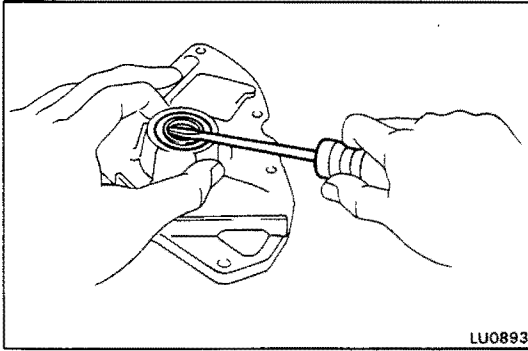

## REPLACEMENT OF OIL PUMP OIL SEAL

### 1. REMOVE OIL SEAL

Using a screwdriver, pry out the oil seal.

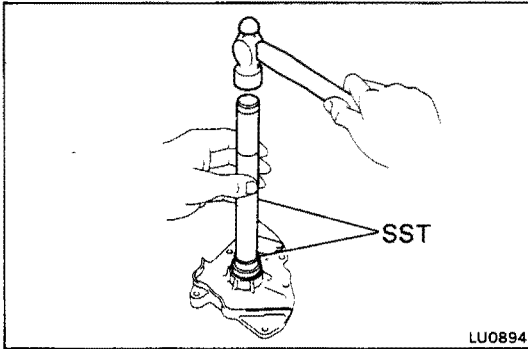

### 2. INSTALL OIL SEAL

(a) Using SST and a hammer, tap in a new oil seal to a depth of approx. 1 mm (0.04 in.) from the oil pump cover edge.

SST 09620-30010 (09627-30010, 09631-00020)

(b) Apply MP grease to the oil seal lip.

## REPLACEMENT OF CRANKSHAFT FRONT OIL SEAL

(See page EM-165)

## ASSEMBLY OF OIL PUMP

(See page EM-11)

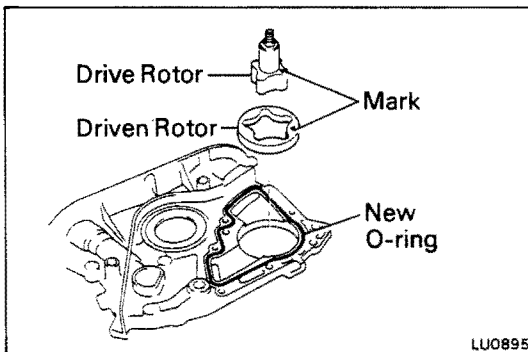

### 1. INSTALL DRIVE AND DRIVEN ROTORS

(a) Place the drive and driven rotors into the pump body with the marks facing the pump body cover side.

(b) Place a new O-ring on the pump body.

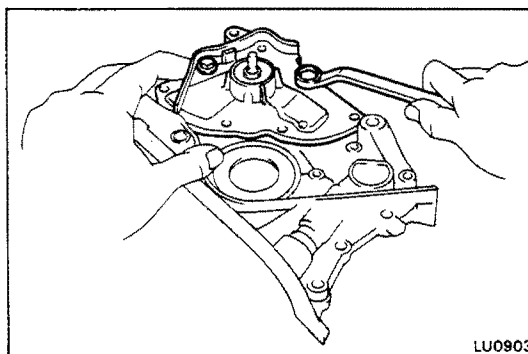

(c) Install the pump body cover with the two bolts.

**Torque: 90 kg-cm (78 in.-lb, 8.8 N·m)**

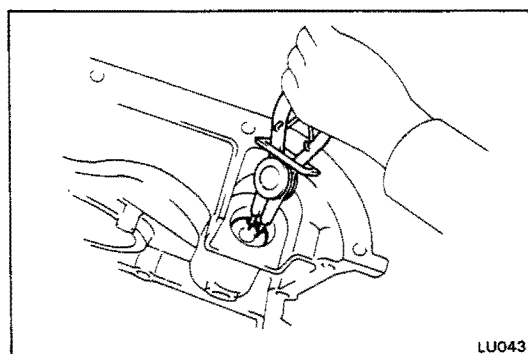

### 2. INSTALL RELIEF VALVE

(a) Insert the relief valve, spring and retainer into the pump body hole.

(b) Using snap ring pliers, install the snap ring.

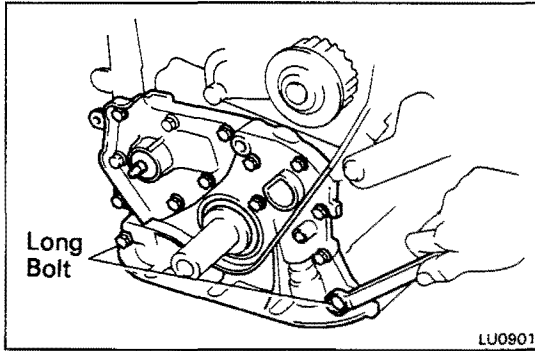

## INSTALLATION OF OIL PUMP

(See page LU-9)

### 1. INSTALL OIL PUMP

Install a new gasket and the oil pump with the twelve bolts.

Torque: 80 kg-cm (69 in.-lb, 7.8 N·m)

HINT: Each bolt length is indicated in the illustration.

Bolt length: Long bolt 35 mm (1.38 in.)  
Others 25 mm (0.98 in.)

### 2. INSTALL OIL PUMP PULLEY, CRANKSHAFT TIMING PULLEY, NO. 1 AND NO. 2 IDLER PULLEYS

(5S-FE: See steps 1 to 4 on page EM-40)

(3S-GE, 3S-GTE: See steps 1 to 4 on page EM-53)

### 3. INSTALL TIMING BELT

(5S-FE: See steps 5 to 17 on pages EM-40 to 44)

(3S-GE, 3S-GTE: See steps 4 to 24 on pages EM-53 to 58)

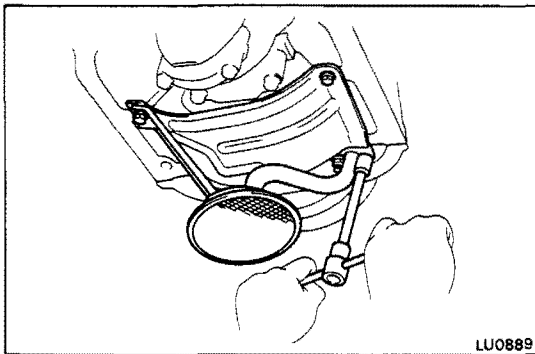

### 4. INSTALL BAFFLE PLATE AND OIL STRAINER

Install a new gasket, the baffle plate and the oil strainer with the two bolts and two nuts.

Torque: 55 kg-cm (48 in.-lb, 5.4 N·m)

### 5. INSTALL OIL PAN

(a) Remove any oil packing (FIPG) material and be careful not to drop any oil on the contact surfaces of the oil pan and cylinder block.

- Using a razor blade and gasket scraper, remove all the old packing (FIPG) material from the gasket surfaces and sealing groove.
- Thoroughly clean all components to remove all the loose material.
- Using a non-residual solvent, clean both sealing surfaces.

**NOTICE:** Do not use a solvent which will affect the painted surfaces.

(b) Apply seal packing to the oil pan as shown in the illustration.

**Seal packing: Part No. 08826-00080 or equivalent**

- Install a nozzle that has cut to a 3 — 5 mm (0.12 — 0.20 in.) opening.

**HINT:** Avoid applying an excessive amount to the surface. Be particularly careful near oil passages.

- Parts must be assembled within 5 minutes of application. Otherwise the material must be removed and reapplied.

- Immediately remove nozzle from the tube and reinstall cap.

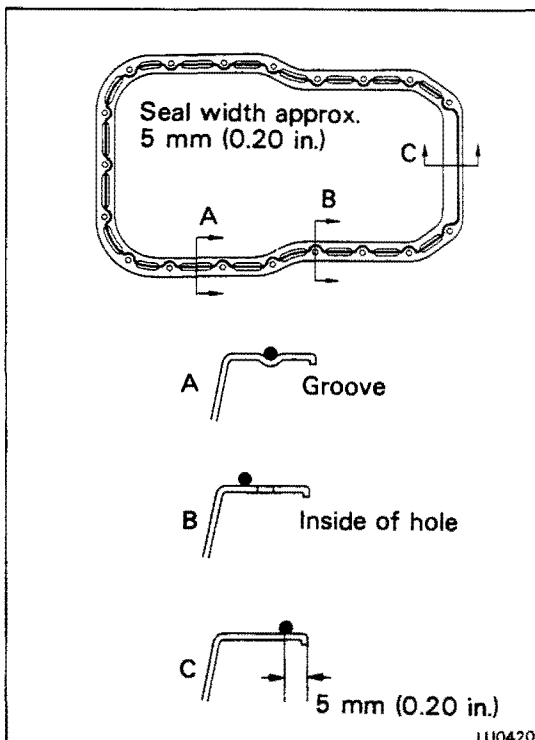

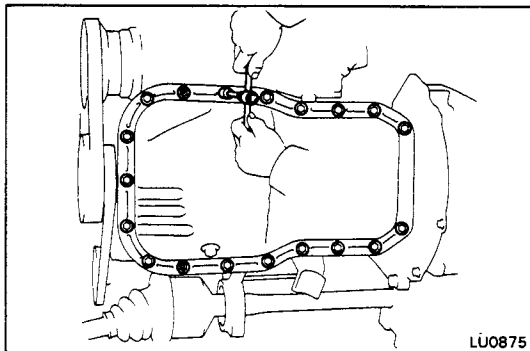

(c) Install the oil pan with the seventeen bolts and four nuts.

**Torque: 55 kg-cm (48 in.-lb, 5.4 N·m)**

(d) Install the dipstick.

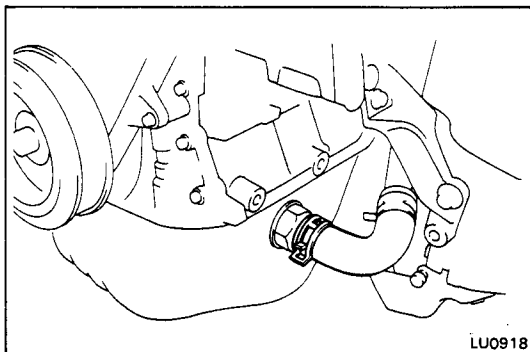

6. **(3S-GTE)**  
**CONNECT TURBOCHARGER OIL OUTLET HOSE TO OIL PAN**

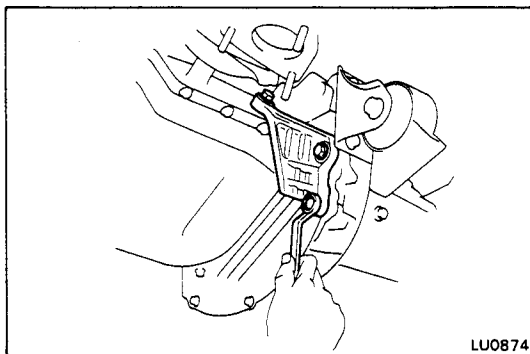

7. **INSTALL STIFFENER PLATE**

Install the stiffener plate with the two bolts.

**Torque: 380 kg-cm (27 ft-lb, 37 N·m)**

8. **FILL WITH ENGINE OIL (See page LU-8)**
9. **START ENGINE AND CHECK FOR LEAKS**
10. **RECHECK ENGINE OIL LEVEL (See page LU-6)**

# OIL COOLER (5S-FE, 3S-GE) COMPONENTS

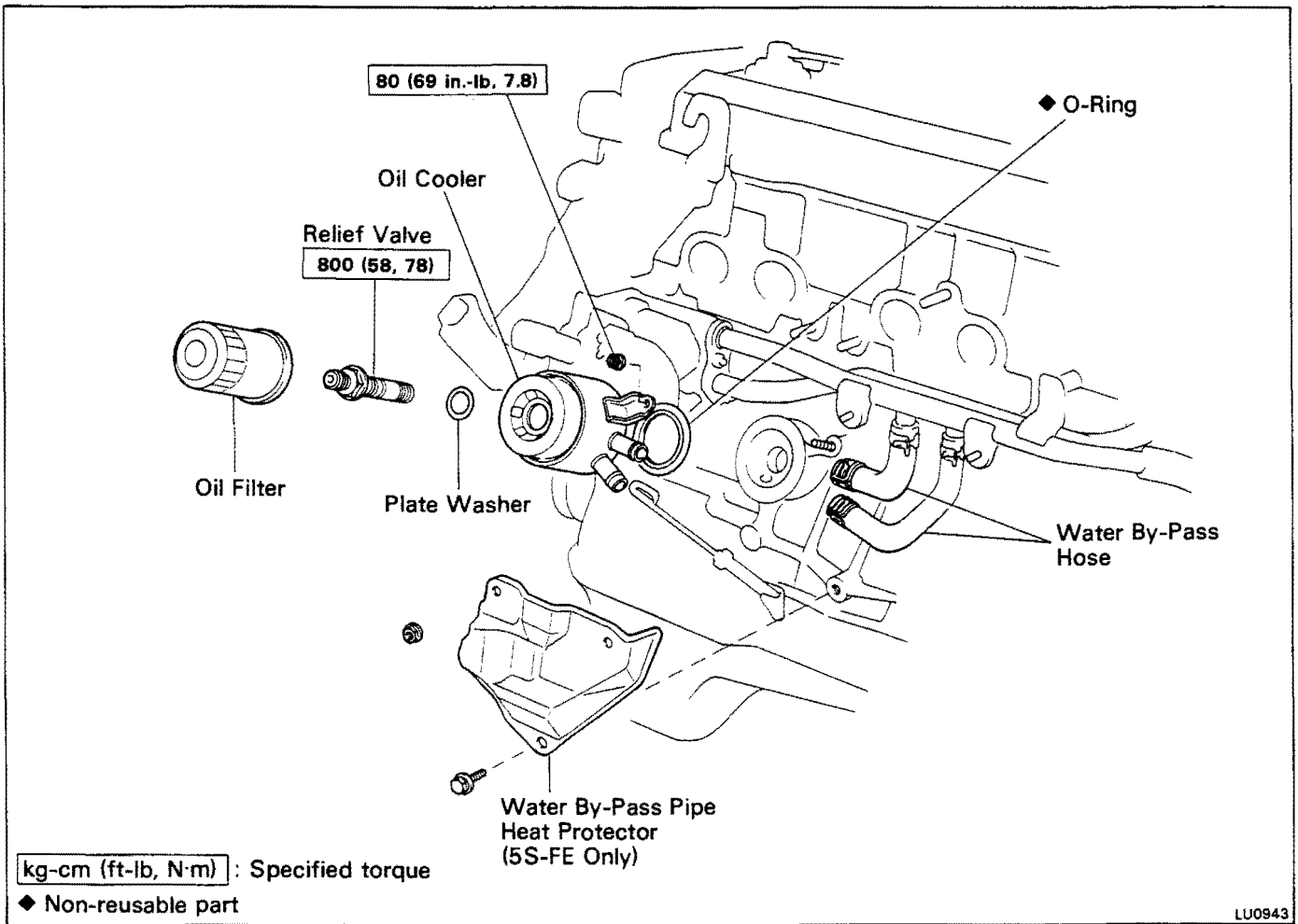

## REMOVAL OF OIL COOLER

1. DRAIN ENGINE COOLANT (See page CO-6)
2. REMOVE ALTERNATOR
3. REMOVE EXHAUST MANIFOLD  
(5S-FE: See step 3 on page EM-65)  
(3S-GE: See step 9 on page EM-110)
4. REMOVE OIL FILTER (See page LU-7)
5. (5S-FE)  
REMOVE WATER BY-PASS HOSE HEAT PROTECTOR  
Remove the bolt, two nuts and heat protector.

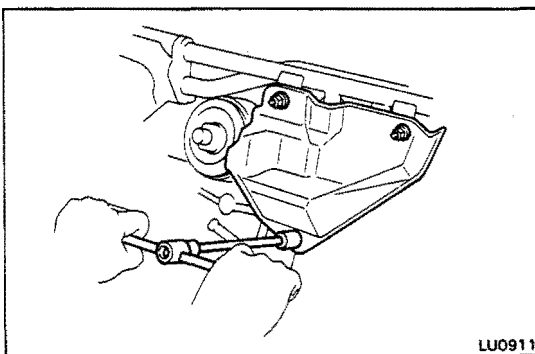



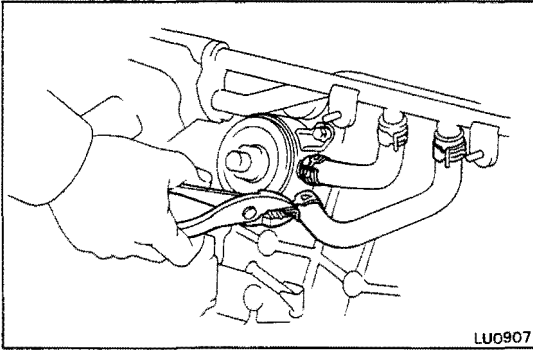

## 6. DISCONNECT WATER BY-PASS HOSES FROM OIL COOLER

Disconnect the two water by-pass hoses.

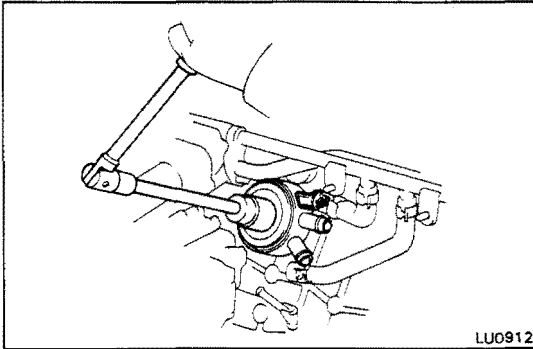

## 7. REMOVE OIL COOLER

- (a) Remove the nut.
- (b) Remove the relief valve, plate washer, oil cooler and gasket.
- (c) Remove the O-ring from the oil cooler.

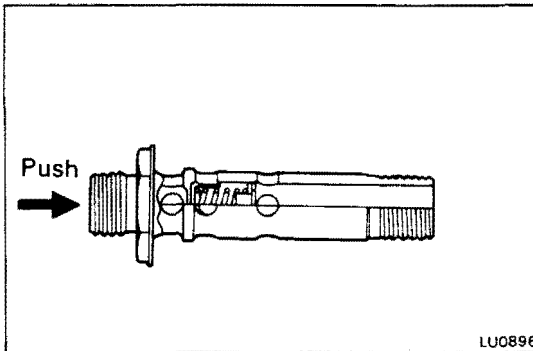

## INSPECTION OF OIL COOLER

### 1. INSPECT RELIEF VALVE

Push the valve with a wooden stick to check if it is stuck. If stuck, replace the relief valve.

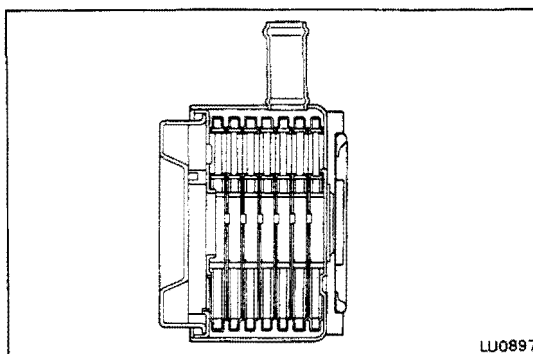

### 2. INSPECT OIL COOLER

Check the oil cooler for damage or clogging. If necessary, replace the oil cooler.

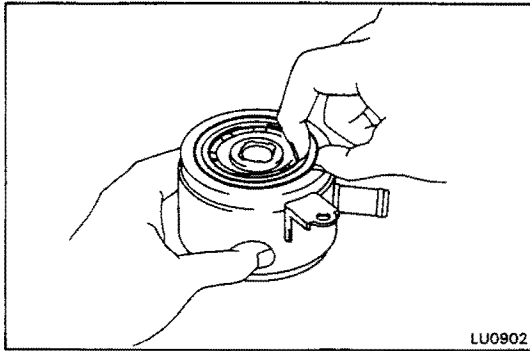

## INSTALLATION OF OIL COOLER

(See page LU-16)

### 1. INSTALL OIL COOLER

(a) Install a new O-ring to the oil cooler.

(b) Apply a light coat of engine oil on the threads and under the head of the relief valve.

(c) Install the oil cooler with the plate washer and relief valve.

**Torque: 800 kg-cm (58 ft-lb, 78 N·m)**

(d) Install the nut.

**Torque: 80 kg-cm (69 in.-lb, 7.8 N·m)**

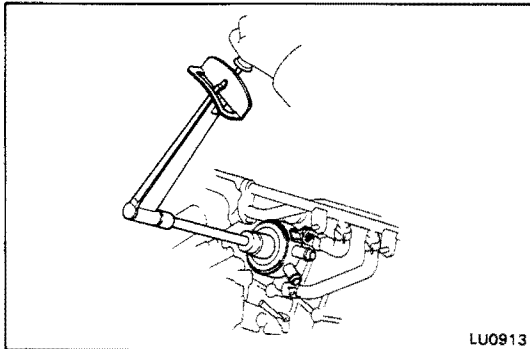

### 2. CONNECT WATER BY-PASS HOSES

Connect the two water by-pass hoses.

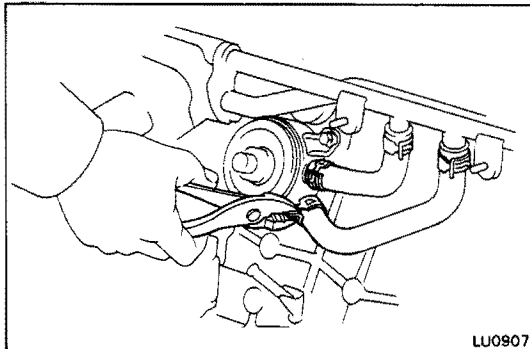

### 3. (5S-FE)

#### INSTALL WATER BY-PASS HOSE HEAT PROTECTOR

Install the heat protector with the bolt and two nuts.

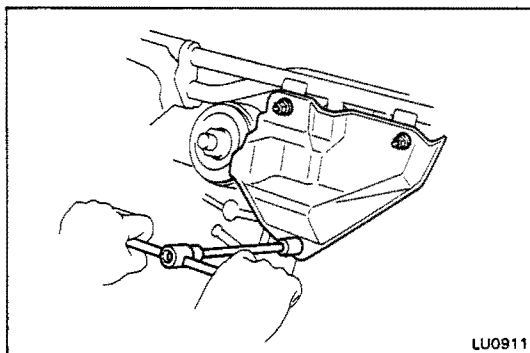

4. INSTALL OIL FILTER (See page LU-7)

5. INSTALL EXHAUST MANIFOLD

(5S-FE: See step 26 on page EM-96)

(3S-GE: See step 24 on pages EM-135, 136)

6. INSTALL ALTERNATOR

7. FILL WITH ENGINE COOLANT (See page CO-6)

8. START ENGINE AND CHECK FOR LEAKS

9. CHECK ENGINE OIL LEVEL (See page LU-6)

## OIL COOLER (3S-GTE) COMPONENTS

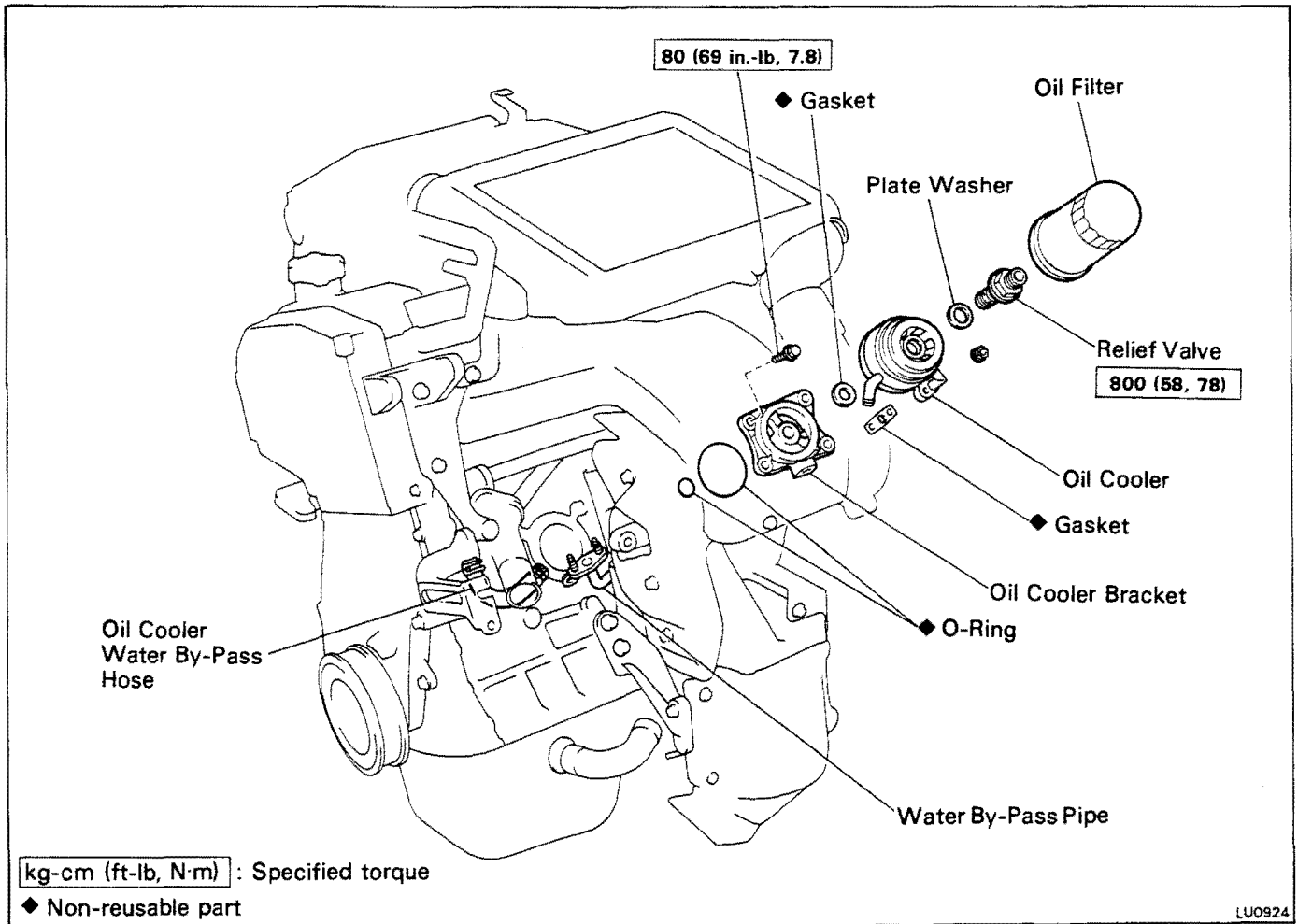

### REMOVAL OF OIL COOLER

1. DRAIN ENGINE COOLANT (See page CO-6)
2. REMOVE ALTERNATOR
3. REMOVE OIL FILTER (See page LU-7)
4. DISCONNECT WATER BY-PASS HOSE FROM OIL COOLER

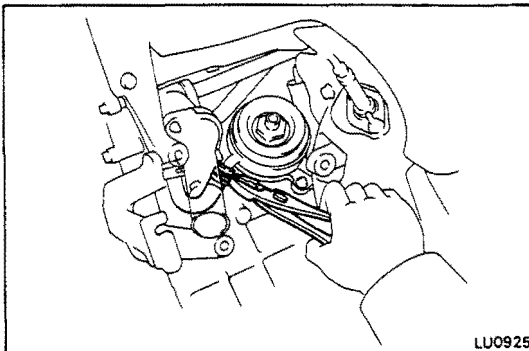

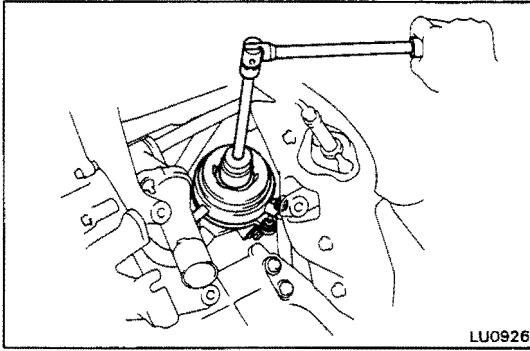

**5. REMOVE OIL COOLER**

- (a) Remove the relief valve and plate washer.
- (b) Remove the two nuts, oil cooler and two gaskets.
- (c) Remove the O-ring from the oil cooler.

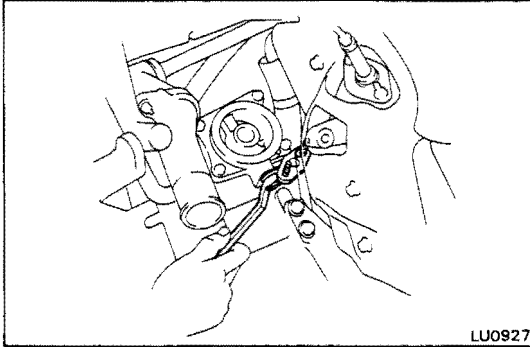

- (d) Remove the bolt, and disconnect the water by-pass pipe from the oil cooler bracket.

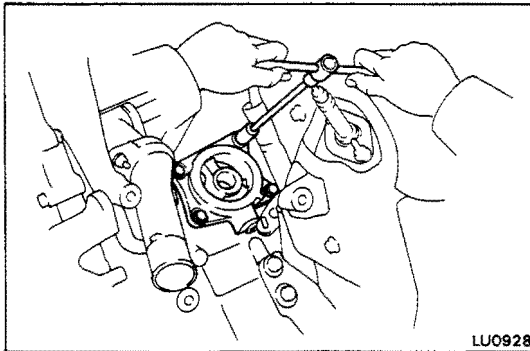

**6. REMOVE OIL COOLER BRACKET**

- (a) Remove the four bolts and oil cooler bracket.
- (b) Remove the two O-rings from the oil cooler.

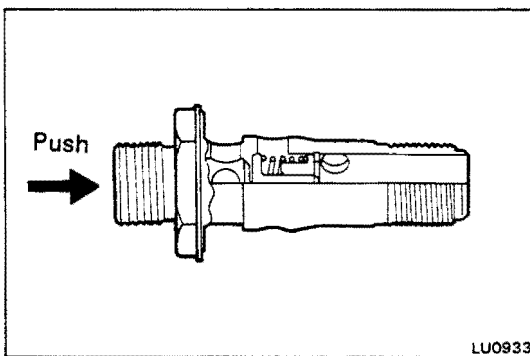

**INSPECTION OF OIL COOLER**

**1. INSPECT RELIEF VALVE**

Push the valve with a wooden stick to check if it is stuck. If stuck, replace the relief valve.

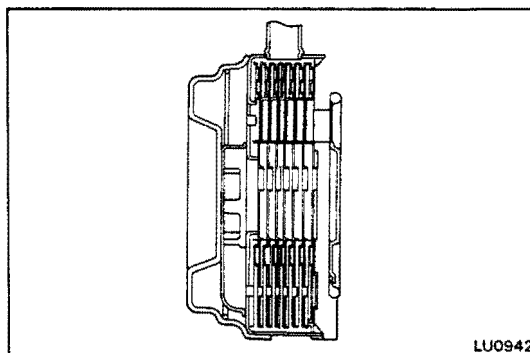

**2. INSPECT OIL COOLER**

Check the oil cooler for damage or clogging. If necessary, replace the oil cooler.

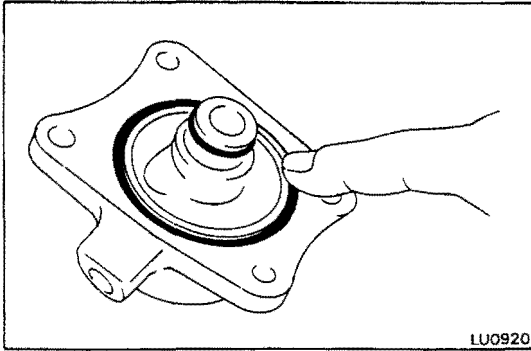

## INSTALLATION OF OIL COOLER

(See page LU-19)

### 1. INSTALL OIL COOLER BRACKET

(a) Install two new O-rings to the oil cooler bracket.

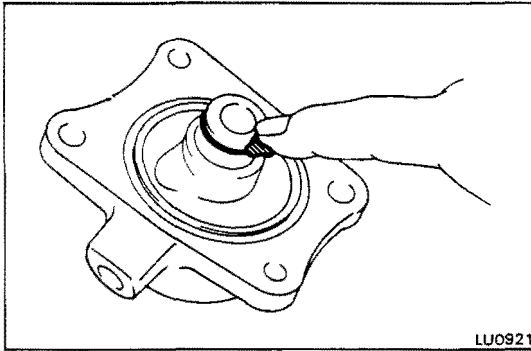

(b) Apply a light coat of engine oil on the small O-ring.

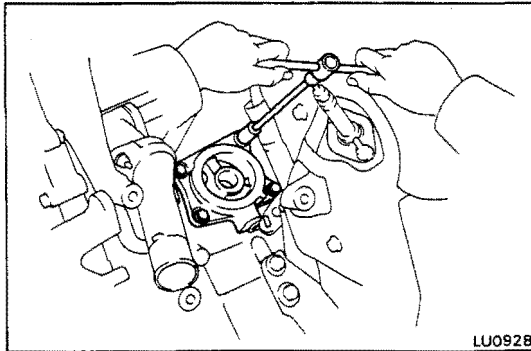

(c) Install the oil cooler bracket with the four bolts.

**Torque: 80 kg-cm (69 in.-lb, 7.8 N·m)**

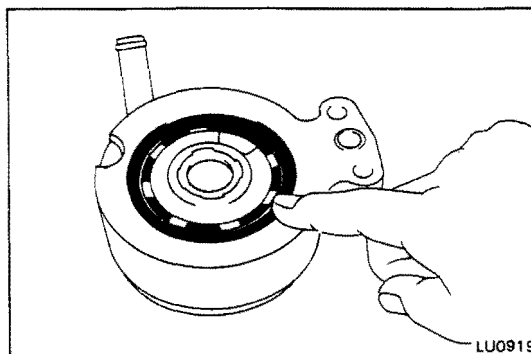

### 2. INSTALL OIL COOLER

(a) Install a new O-ring to the oil cooler.

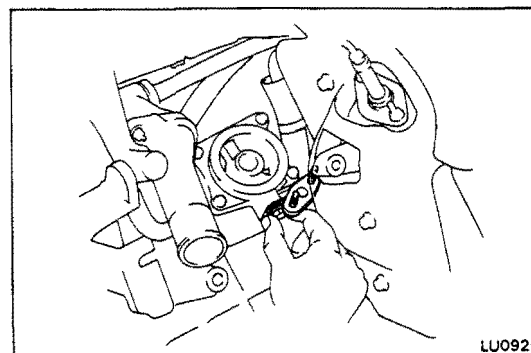

(b) Temporarily install the water by-pass pipe with the bolt.

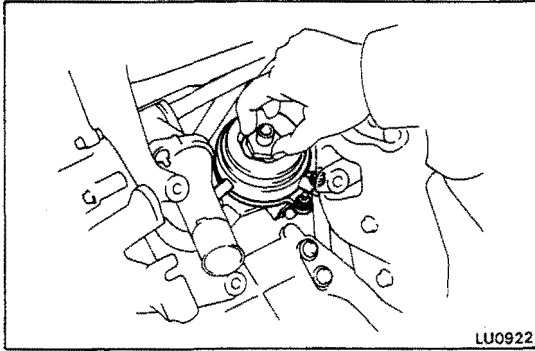

- (c) Apply a light coat of engine oil on the threads and under the head of the relief valve.
- (d) Temporarily install two new gaskets and the oil cooler with the plate washer, relief valve and two nuts.

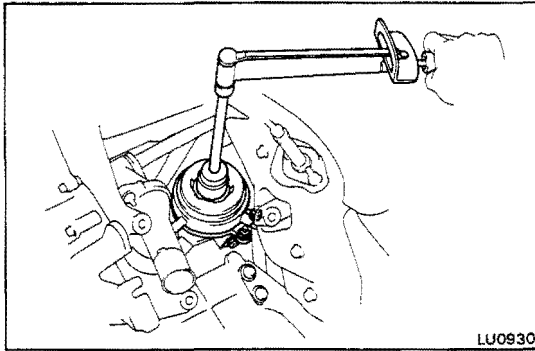

- (e) Tighten the relief valve.  
**Torque: 800 kg-cm (58 ft-lb, 78 N·m)**
- (f) Tighten the two nuts holding the oil cooler to the water by-pass pipe.  
**Torque: 120 kg-cm (9 ft-lb, 12 N·m)**
- (g) Tighten the bolt holding the water by-pass pipe to oil cooler bracket.  
**Torque: 180 kg-cm (13 ft-lb, 18 N·m)**

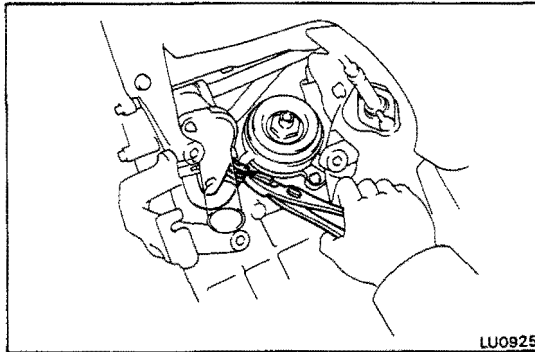

### 3. CONNECT WATER BY-PASS HOSE TO OIL COOLER

- 4. INSTALL OIL FILTER (See page LU-7)
- 5. INSTALL ALTERNATOR
- 6. FILL WITH ENGINE COOLANT (See page CO-6)
- 7. START ENGINE AND CHECK FOR LEAKS
- 8. CHECK ENGINE OIL LEVEL (See page LU-6)

## OIL COOLER (3S-GTE) COMPONENTS

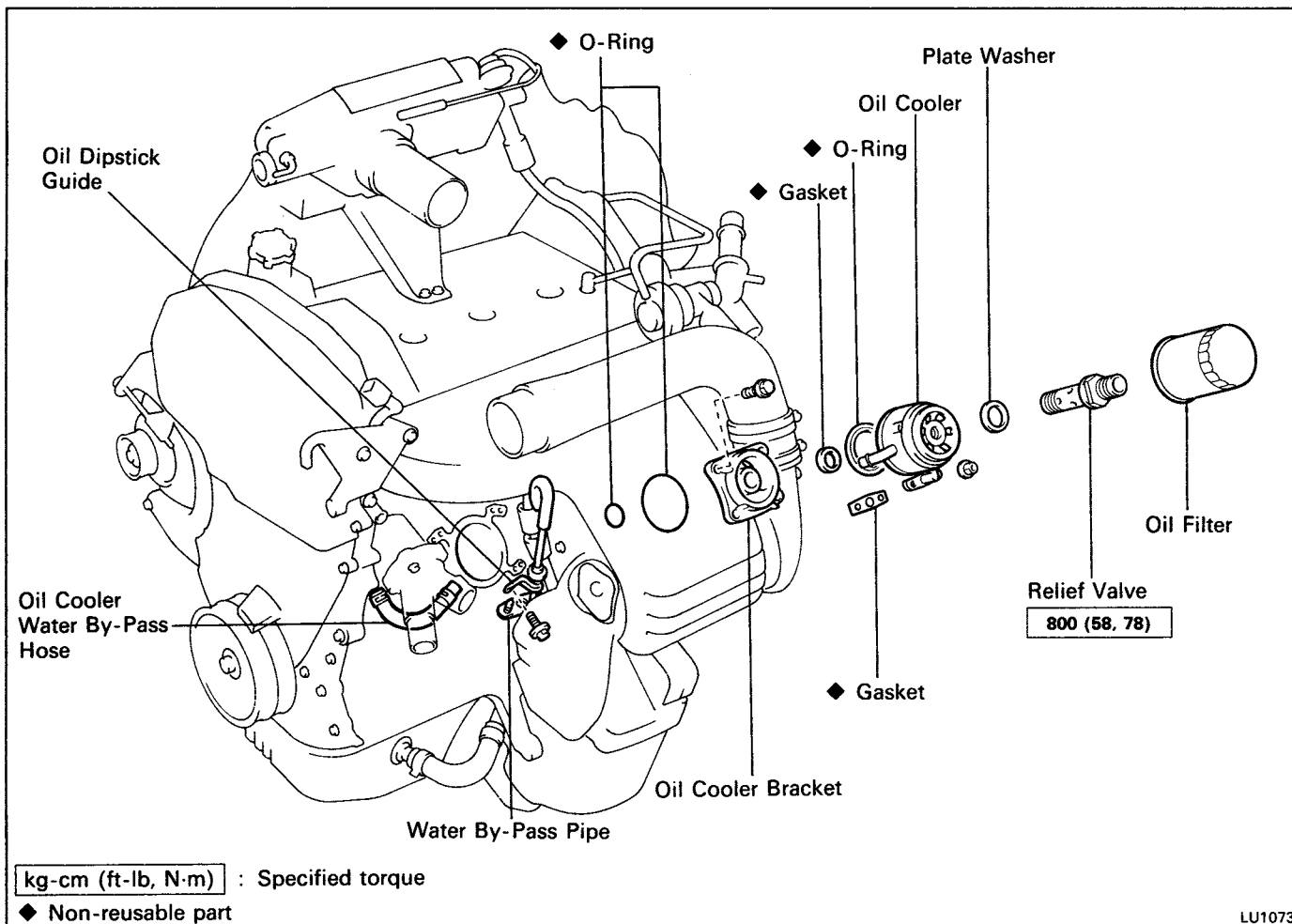

### REMOVAL OF OIL COOLER

1. **DISCONNECT CABLE FROM NEGATIVE TERMINAL OF BATTERY**  
**CAUTION:** Work must be started after approx. 20 seconds or longer from the time the ignition switch is turned to the "LOCK" position and the negative (-) terminal cable is disconnected from the battery.
2. **DRAIN ENGINE COOLANT (See page CO-6)**
3. **REMOVE ENGINE UNDER COVERS**
4. **REMOVE RH ENGINE HOOD SIDE PANEL**
5. **REMOVE NO.1 AIR INTAKE CONNECTOR (See step 4 on page TC-20)**
6. **REMOVE A/C COMPRESSOR WITHOUT DISCONNECTING HOSES (See steps 10 to 12 on pages TC-21 and 22)**
7. **REMOVE OIL FILTER (See page LU-7)**

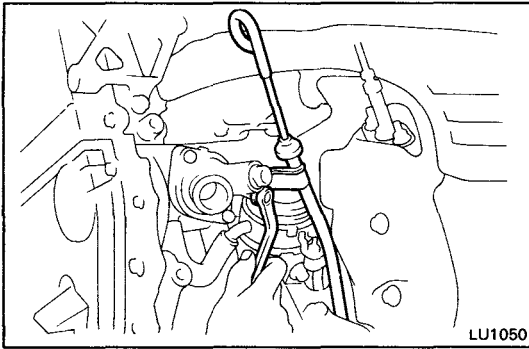

- 8. DISCONNECT OIL DIPSTICK GUIDE FROM WATER INLET**

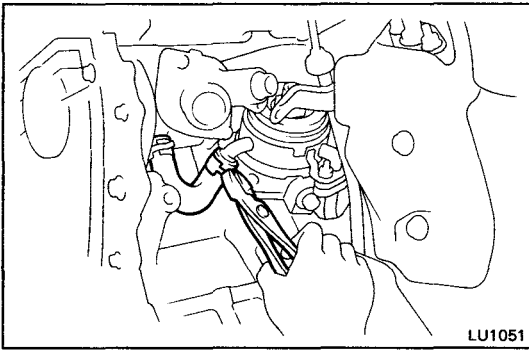

- 9. DISCONNECT WATER BY-PASS HOSE FROM OIL COOLER**

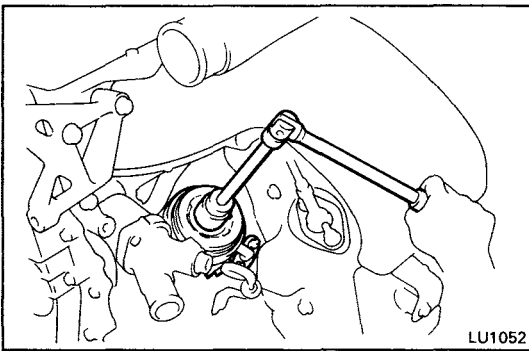

- 10. REMOVE OIL COOLER**

- (a) Remove the relief valve and plate washer.
- (b) Remove the two nuts, oil cooler and gasket.
- (c) Remove the O-ring and gasket from the oil cooler.

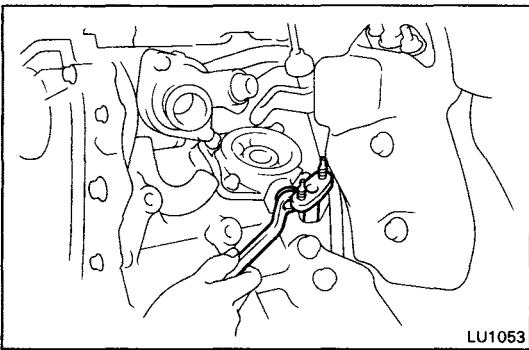

- (d) Remove the bolt, and disconnect the water by-pass pipe from the oil cooler bracket.

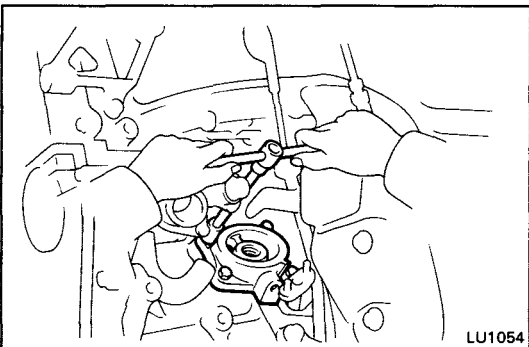

- 11. REMOVE OIL COOLER BRACKET**

- (a) Remove the four bolts and oil cooler bracket.
- (b) Remove the two O-rings from the oil cooler.



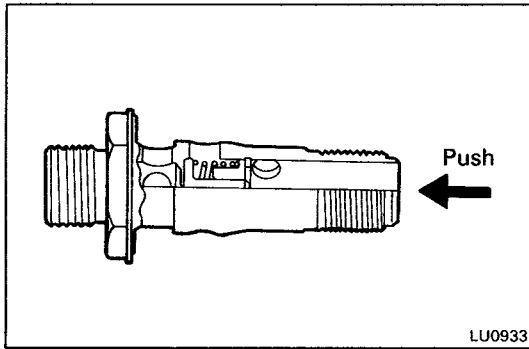

## INSPECTION OF OIL COOLER

### 1. INSPECT RELIEF VALVE

Push the valve with a wooden stick to check if it is stuck.  
If stuck, replace the relief valve.

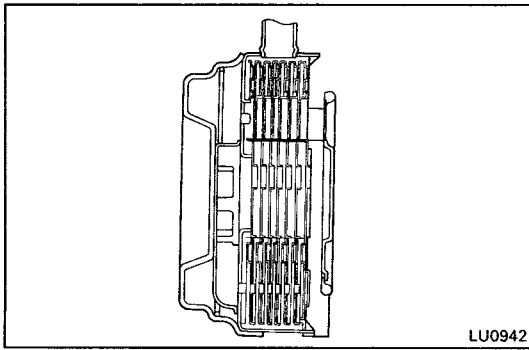

### 2. INSPECT OIL COOLER

Check the oil cooler for damage or clogging.  
If necessary, replace the oil cooler.

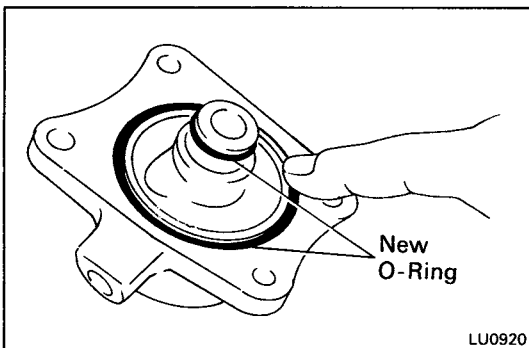

## INSTALLATION OF OIL COOLER

(See page LU-18)

### 1. INSTALL OIL COOLER BRACKET

- (a) Install two new O-rings to the oil cooler bracket.
- (b) Apply a light coat of engine oil on the small O-ring.

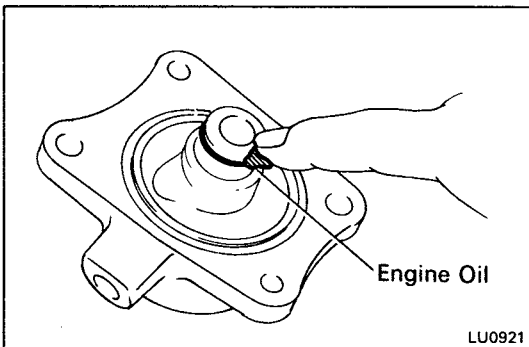

- (c) Install the oil cooler bracket with the four bolts.

**Torque: 80 kg-cm (69 in.-lb, 7.8 N·m)**

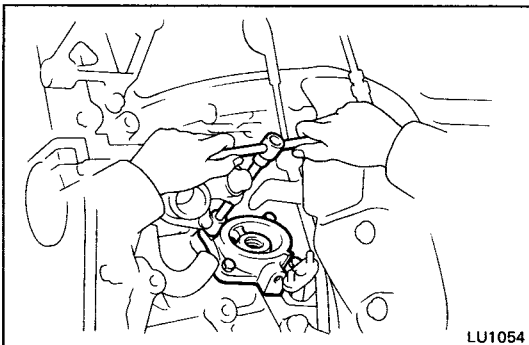

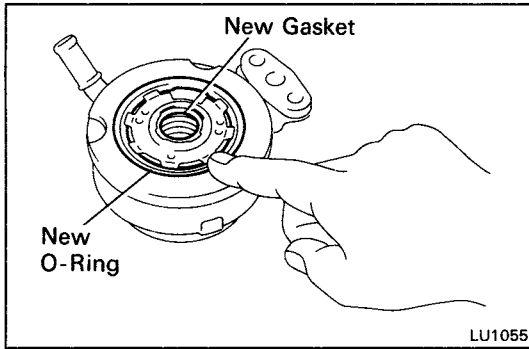

## 2. INSTALL OIL COOLER

(a) Install new O-ring and gasket to the oil cooler.

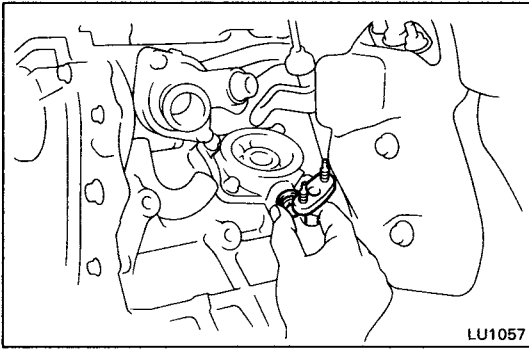

(b) Temporarily install the water by-pass pipe with the bolt.

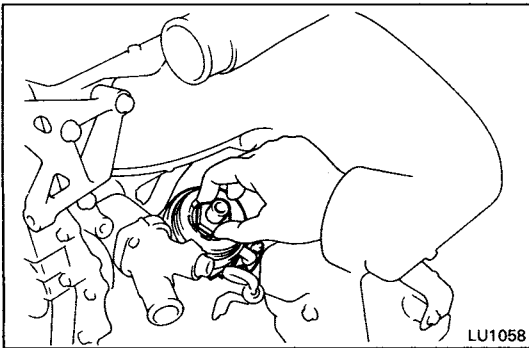

(c) Apply a light coat of engine oil on the threads and under the head of the relief valve.

(d) Place a new gasket on the water by-pass pipe.

(e) Temporarily install the oil cooler with the plate washer, relief valve and two nuts.

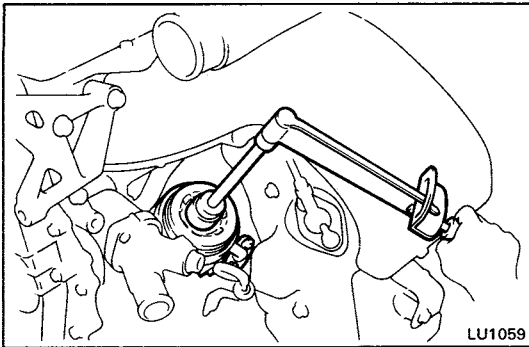

(f) Tighten the relief valve.

**Torque: 800 kg-cm (58 ft-lb, 78 N·m)**

(g) Tighten the two nuts holding the oil cooler to the water by-pass pipe.

**Torque: 120 kg-cm (9 ft-lb, 12 N·m)**

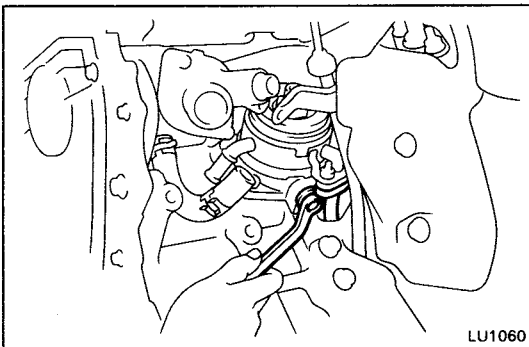

(h) Tighten the bolt holding the water by-pass pipe to oil cooler bracket.

**Torque: 180 kg-cm (13 ft-lb, 18 N·m)**

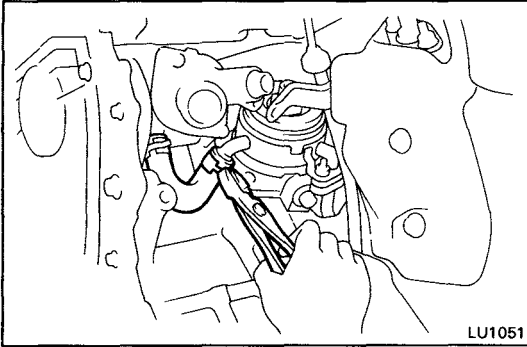

3. CONNECT WATER BY-PASS HOSE TO OIL COOLER

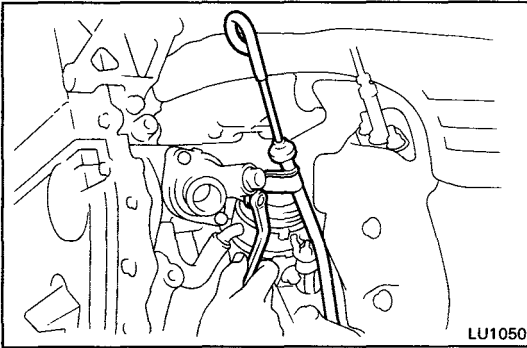

4. INSTALL OIL DIPSTICK GUIDE TO WATER INLET

5. INSTALL OIL FILTER (See page LU-7)
6. INSTALL A/C COMPRESSOR  
(See steps 3 to 5 on pages TC-23 and 24)
7. INSTALL NO.1 AIR INTAKE CONNECTOR  
(See step 10 on page TC-25)
8. INSTALL RH ENGINE HOOD SIDE PANEL
9. CONNECT CABLE TO NEGATIVE TERMINAL OF BATTERY
10. FILL WITH ENGINE COOLANT (See page CO-7)
11. START ENGINE AND CHECK FOR LEAKS
12. CHECK ENGINE OIL LEVEL (See page LU-6)
13. INSTALL ENGINE UNDER COVERS

## OIL NOZZLES (3S-GTE) COMPONENTS

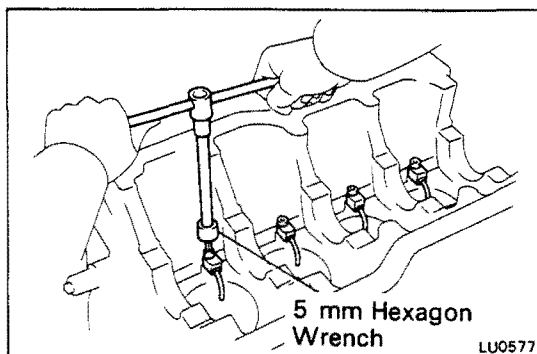
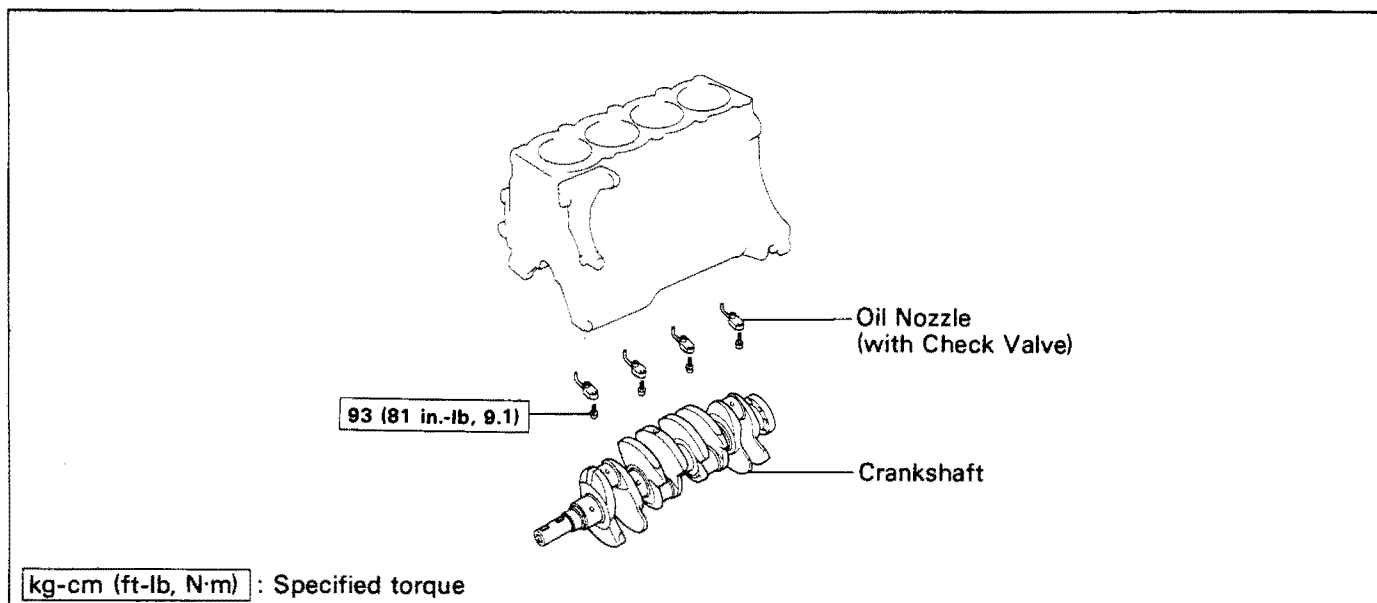

### REMOVAL OF OIL NOZZLES

1. REMOVE CRANKSHAFT  
(5S-FE: See pages EM-149 to 155)  
(3S-GE, 3S-GTE: See pages EM-175 to 181)
2. REMOVE OIL NOZZLES (WITH RELIEF VALVES)

Using a 5 mm hexagon wrench, remove the bolt and oil nozzle. Remove the four oil nozzles.

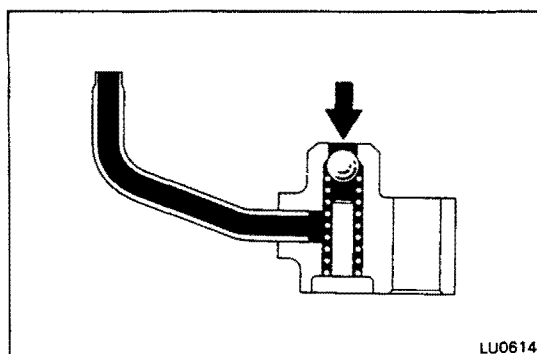

### INSPECTION OF OIL NOZZLES

#### INSPECT RELIEF VALVES (OIL NOZZLES)

Push the valve with a wooden stick to check if it is stuck. If stuck, replace the relief valve.

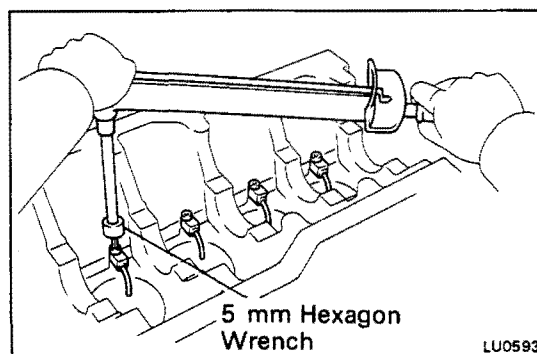

### INSTALLATION OF OIL NOZZLES

1. INSTALL OIL NOZZLES (WITH RELIEF VALVES)  
Using a 5 mm hexagon wrench, install the oil nozzle with the bolt. Install the four oil nozzles.  
Torque: 93 kg-cm (81 in.-lb, 9.1 N·m)
2. INSTALL CRANKSHAFT  
(5S-FE: See pages EM-169 to 173)  
(3S-GE, 3S-GTE: See pages EM-193 to 197)

---

# IGNITION SYSTEM

	Page
PRECAUTIONS .....	IG-2
TROUBLESHOOTING .....	IG-3
IGNITION SYSTEM CIRCUIT .....	IG-4
ON-VEHICLE INSPECTION .....	IG-5
DISTRIBUTOR .....	IG-13

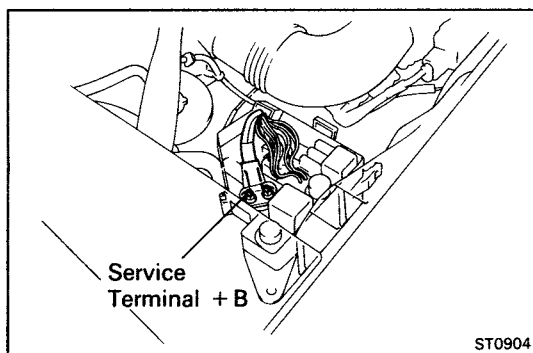
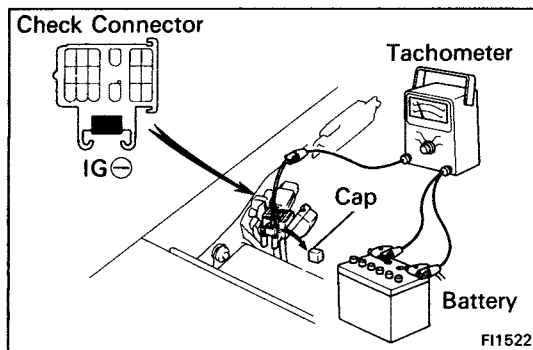

## PRECAUTIONS

1. Do not leave the ignition switch on for more than 10 minutes if the engine will not start.
2. With a tachometer connected to the system, connect the test probe of the tachometer to terminal IG $\ominus$  of the check connector.
3. With a tachometer connected to the system, connect the power source probe of the tachometer to service terminal + B of the engine compartment relay box.
4. As some tachometers are not compatible with this ignition system, we recommend that you confirm the compatibility of yours before use.
5. NEVER allow the tachometer terminal to touch ground as this could damage the igniter and/or ignition coil.
6. Do not disconnect the battery when the engine is running.
7. Check that the igniter is properly grounded to the body.

## TROUBLESHOOTING

Problem	Possible cause	Remedy	Page
Engine will not start/ hard to start (cranks ok)	Incorrect ignition timing Ignition problems <ul style="list-style-type: none"> <li>● Ignition coil</li> <li>● Igniter</li> <li>● Distributor</li> <li>● High-tension cords</li> </ul> Ignition wiring disconnected or broken	Reset timing  Inspect coil Inspect igniter Inspect distributor Inspect high-tension cords  Inspect wiring	IG-10 IG-11 IG-6
Rough idle or stalls	Spark plug faulty Ignition wiring faulty Incorrect ignition timing Ignition problems <ul style="list-style-type: none"> <li>● Ignition coil</li> <li>● Igniter</li> <li>● Distributor</li> <li>● High-tension cords</li> </ul>	Inspect plugs Inspect wiring Reset timing  Inspect coil Inspect igniter Inspect distributor Inspect high-tension cords	IG-7 EM-22, 23 IG-10 IG-11 IG-6
Engine hesitates/ poor acceleration	Spark plug faulty Ignition wiring faulty Incorrect ignition timing	Inspect plugs Inspect wiring Reset timing	IG-7 EM-22, 23
Engine dieseling (runs after ignition switch is turned off)	Incorrect ignition timing	Reset timing	EM-22, 23
Muffler explosion (after fire) all the time	Incorrect ignition timing	Reset timing	EM-22, 23
Engine backfires	Incorrect ignition timing	Reset timing	EM-22, 23
Poor gasoline mileage	Spark plug faulty Incorrect ignition timing	Inspect plugs Reset timing	IG-7 EM-22, 23
Engine overheats	Incorrect ignition timing	Reset timing	EM-22, 23

# IGNITION SYSTEM CIRCUIT

5S-FE

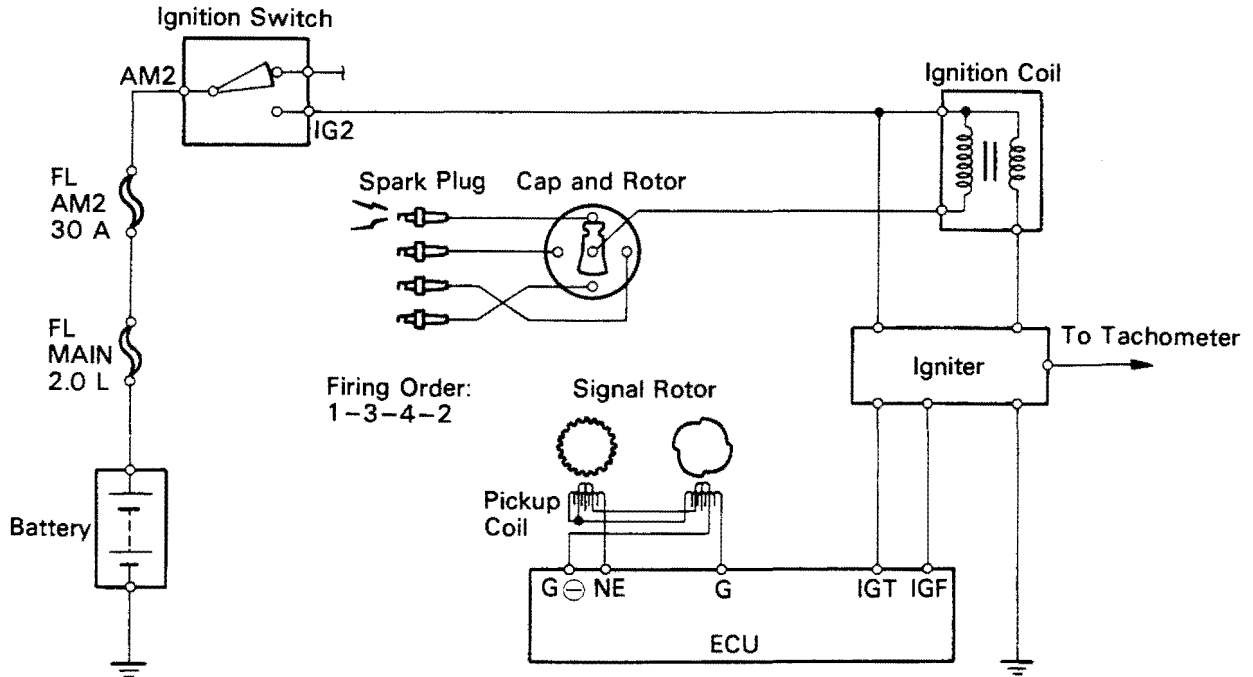

3S-GE and 3S-GTE

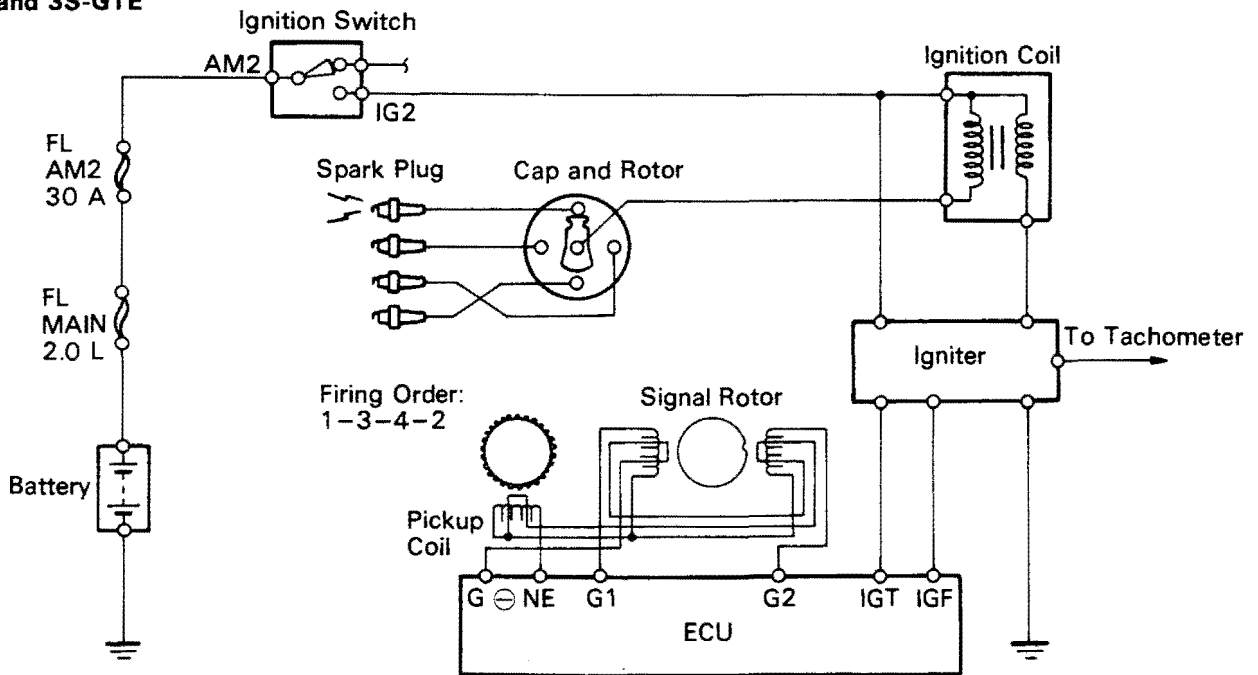

IG1311  
IG1334

## ELECTRONIC SPARK ADVANCE (ESA)

The ECU is programmed with data for optimum ignition timing under any and all operating conditions. Using data provided by sensors which monitor various engine functions (rpm, intake air volume, eng. temperature, etc.) the microcomputer (ECU) triggers the spark at precisely the right instant.



# ON-VEHICLE INSPECTION

## SPARK TEST

### CHECK THAT SPARK OCCURS

- (a) Disconnect the high-tension cord from the distributor.
- (b) Hold the end about 12.5 mm (0.50 in.) from the body of car.
- (c) Check if spark occurs while engine is being cranked.

HINT: To prevent gasoline from being injected from injectors during this test, crank the engine for no more than 1 – 2 seconds at a time.

If spark does not occur, perform the test as follows:

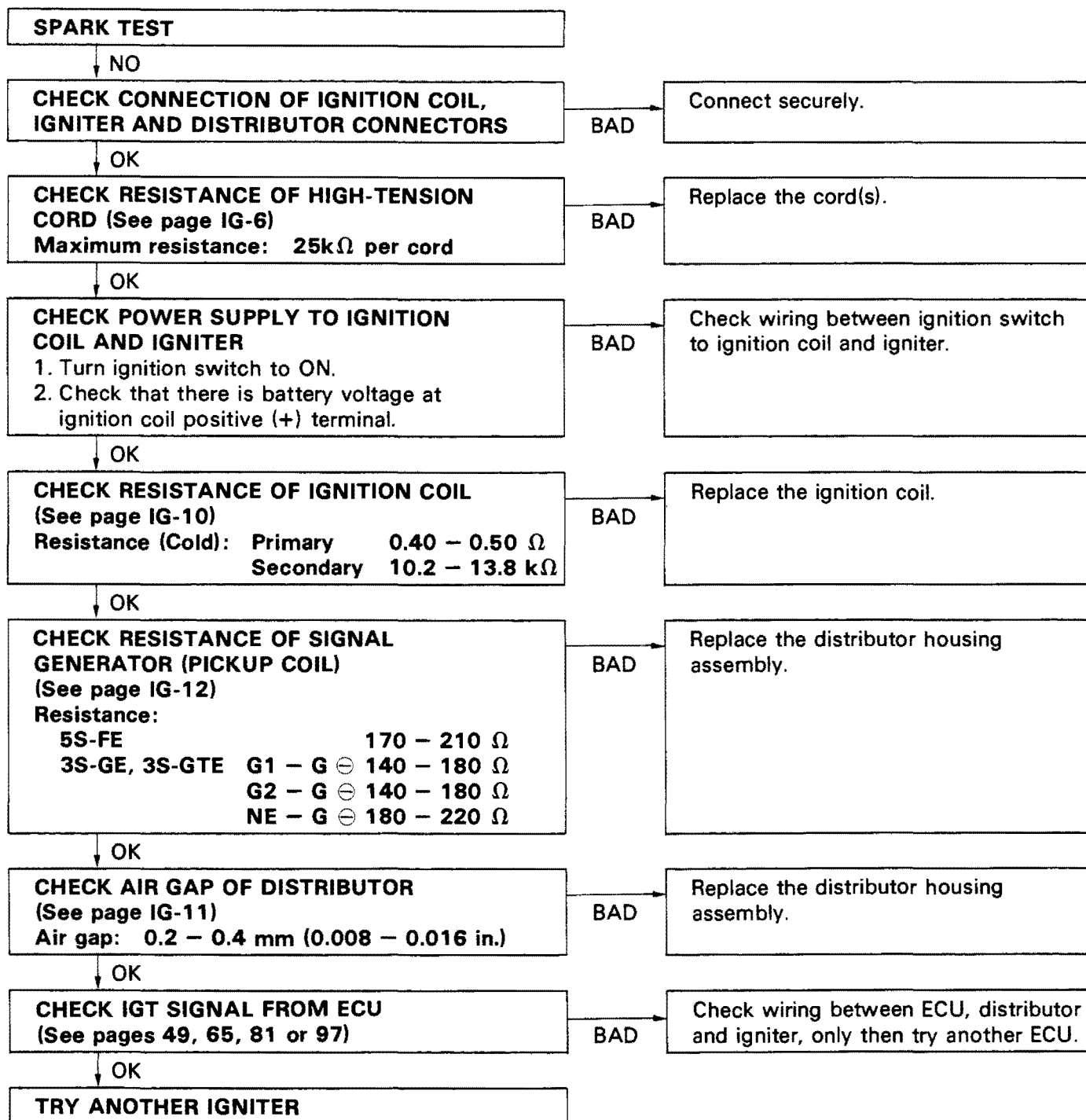

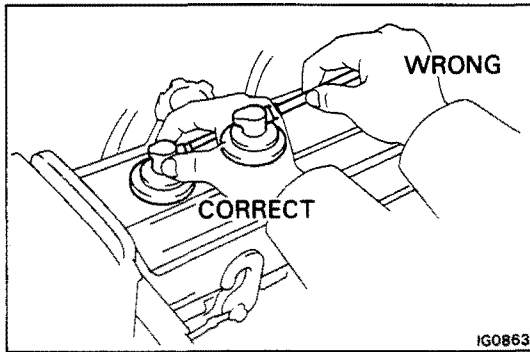

## INSPECTION OF HIGH-TENSION CORDS

1. **(3S-GTE)**  
**REMOVE INTERCOOLER**  
(See steps 4 to 6 on page TC-9)
2. **DISCONNECT HIGH-TENSION CORDS FROM SPARK PLUGS**  
Disconnect the high-tension cords at the rubber boot. DO NOT pull on the cords.  
**NOTICE:** Pulling on or bending the cords may damage the conductor inside.
3. **DISCONNECT HIGH-TENSION CORD FROM IGNITION COIL**
4. **REMOVE DISTRIBUTOR CAP WITHOUT DISCONNECTING HIGH-TENSION CORDS**

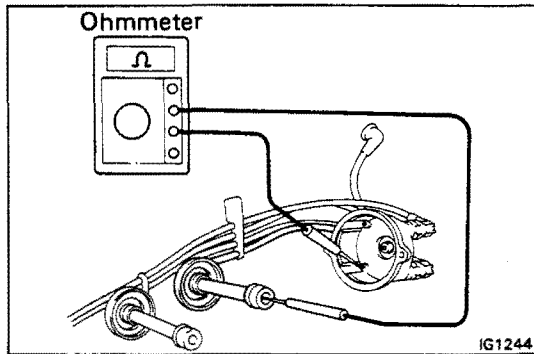

5. **INSPECT HIGH-TENSION CORD RESISTANCE**  
Using an ohmmeter, measure the resistance without disconnecting the distributor cap.  
**Maximum resistance: 25 k $\Omega$  per cord**  
If the resistance is greater than maximum, check the terminals. If necessary, replace the high-tension cord and/or distributor cap.
6. **REINSTALL DISTRIBUTOR CAP**
7. **RECONNECT HIGH-TENSION CORD TO IGNITION COIL**
8. **RECONNECT HIGH-TENSION CORDS TO SPARK PLUGS**
9. **(3S-GTE)**  
**REINSTALL INTERCOOLER**  
(See steps 11 to 13 on page TC-16)

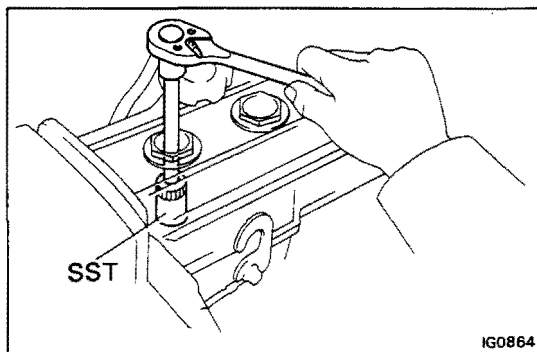

## INSPECTION OF SPARK PLUGS

### (Conventional Type)

- 1. DISCONNECT HIGH-TENSION CORDS FROM SPARK PLUGS**

- 2. REMOVE SPARK PLUGS**

Using SST, remove the spark plug.

SST 09155-16100

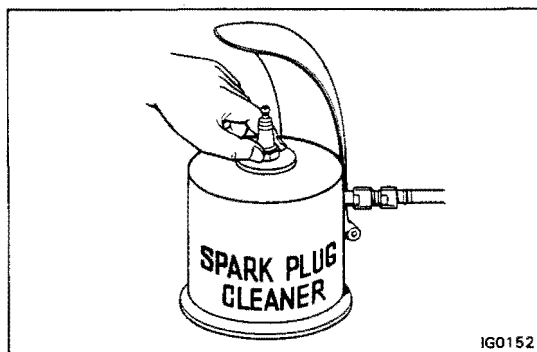

- 3. CLEAN SPARK PLUGS**

Using a spark plug cleaner or wire brush, clean the spark plug.

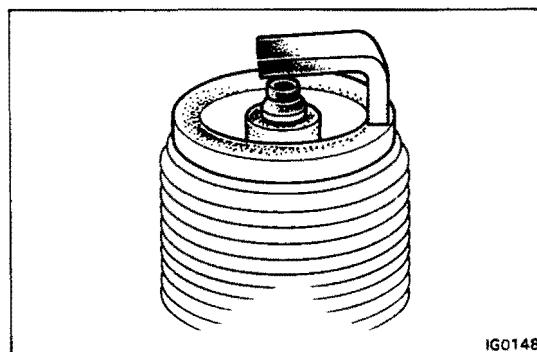

- 4. VISUALLY INSPECT SPARK PLUGS**

Check the spark plug for electrode wear, thread damage and insulator damage.

If abnormal, replace the plugs.

**Recommended spark plug:**

5S-FE	ND	K16R-U11
	NGK	BKR5EYA-11

3S-GE	ND	K20R-U
	NGK	BKR6EYA

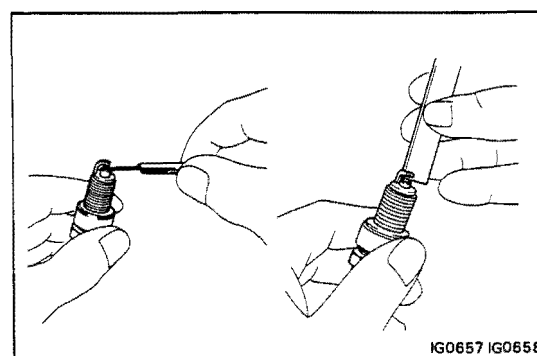

- 5. ADJUST ELECTRODE GAP**

Carefully bent the outer electrode to obtain the correct electrode gap.

**Correct electrode gap:**

5S-FE	1.1 mm (0.043 in.)
3S-GE	0.8 mm (0.031 in.)

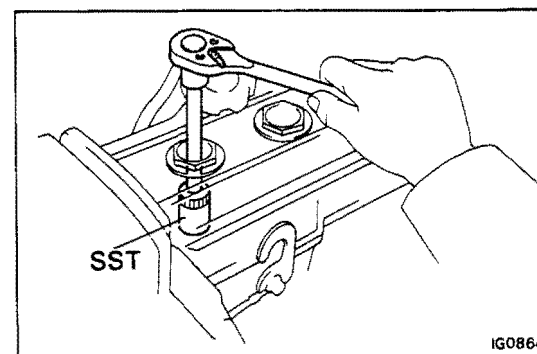

- 6. INSTALL SPARK PLUGS**

Using SST, install and torque the spark plug.

SST 09155-16100

**Torque:** 180 kg-cm (13 ft-lb, 18 N·m)

- 7. RECONNECT HIGH-TENSION CORDS TO SPARK PLUGS**

**(Platinum Tipped Type)****NOTICE:**

- Never use a wire brush for cleaning.
- Never attempt to adjust gap on used plug.
- Spark plugs should be replaced every 60,000 miles (100,000 km)

1. **(3S-GTE)**  
**REMOVE INTERCOOLER**  
(See steps 4 to 6 on page TC-9)

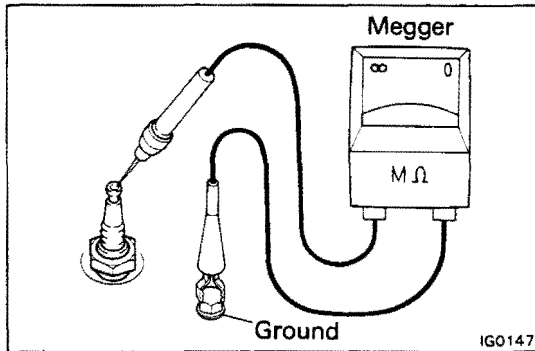

2. **DISCONNECT HIGH-TENSION CORDS FROM SPARK PLUGS**

3. **INSPECT ELECTRODE**

Using a megger (insulation resistance meter), measure the insulation resistance.

**Standard insulation resistance: More than 10MΩ**

If less than 10 MΩ, proceed to step 4.

**HINT:** If a megger is not available, the following simple method of inspection provides fairly accurate results.

[Simple method]

- Quickly race the engine to 4,000 rpm five times.
- Using SST, remove the spark plug.

SST 09155-16100

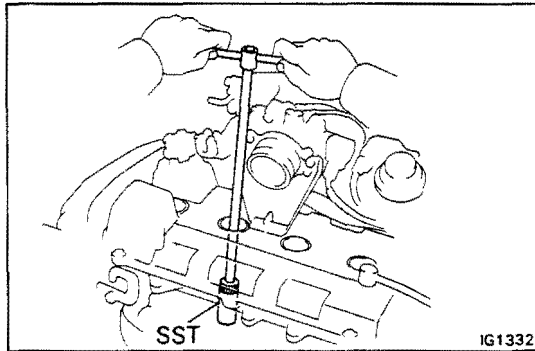

- Visually inspect the spark plugs.

If the electrode is dry . . . Okay

If the electrode is wet . . . Proceed to step 5

4. **REMOVE SPARK PLUGS**

Using SST, remove the spark plug.

SST 09155-16100

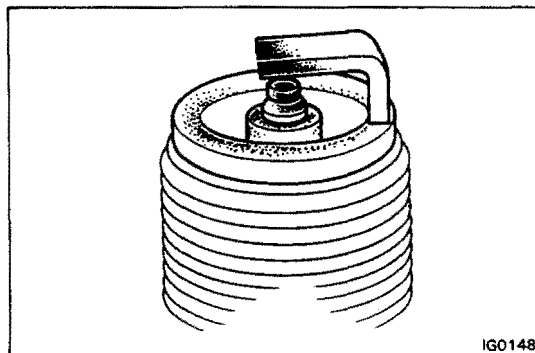

5. **VISUALLY INSPECT SPARK PLUGS**

Check the spark plug for thread or insulator damage.

If abnormal, replace the plug.

**Recommended spark plugs:**

**ND PK20R8**  
**NGK BKR6EP8**

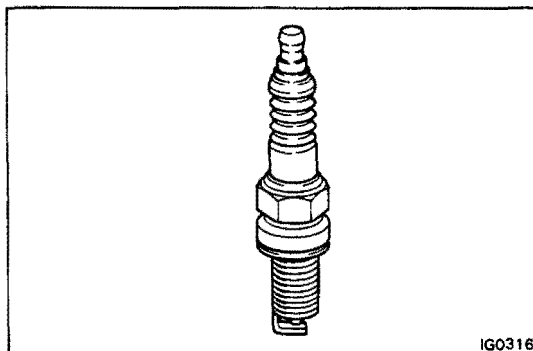

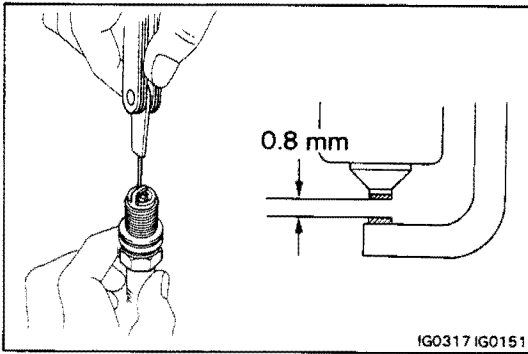
**6. INSPECT ELECTRODE GAP**

**Maximum electrode gap: 1.0 mm (0.39 in.)**

If the gap is greater than maximum, replace the plug.

**Correct electrode gap of new plug: 0.8 mm (0.031 in.)**

If adjusting the gap of a new plug, bend only the base of the ground electrode, do not touch the tip.

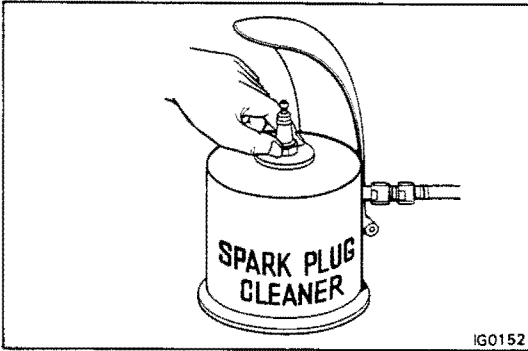
**7. CLEAN SPARK PLUGS**

If the electrode has traces of wet carbon, allow it to dry and then clean with a spark plug cleaner.

**Air pressure: Below 6 kg/cm<sup>2</sup> (85 psi, 588 kPa)**

**Duration: 20 seconds or less**

**HINT:** If there are traces of oil, remove it with gasoline before using the spark plug cleaner.

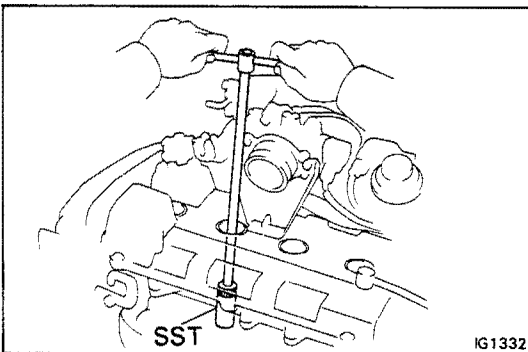
**8. INSTALL SPARK PLUGS**

Using SST, install and torque the spark plug.

SST 09155-16100

**Torque: 180 kg-cm (13 ft-lb, 18 N·m)**

**9. RECONNECT HIGH-TENSION CORDS TO SPARK PLUGS****10. (3S-GTE)**

**REINSTALL INTERCOOLER**

(See steps 11 to 13 on page TC-16)

## INSPECTION OF IGNITION COIL

1. DISCONNECT IGNITION COIL CONNECTOR
2. DISCONNECT HIGH-TENSION CORD

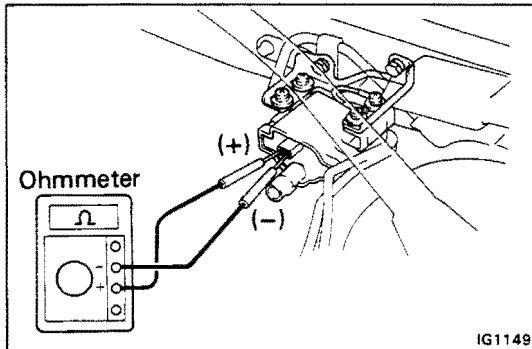

3. INSPECT PRIMARY COIL RESISTANCE

Using an ohmmeter, measure the resistance between positive (+) and negative (-) terminals.

**Primary coil resistance (Cold): 0.40 – 0.50  $\Omega$**

If the resistance is not as specified, replace the ignition coil.

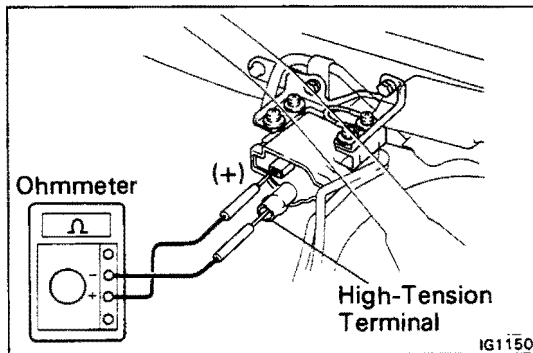

4. INSPECT SECONDARY COIL RESISTANCE

Using an ohmmeter, measure the resistance between positive (+) and high-tension terminals.

**Secondary coil resistance (Cold): 10.2 – 13.8 k $\Omega$**

If the resistance is not as specified, replace the ignition coil.

5. RECONNECT HIGH-TENSION CORD
6. RECONNECT IGNITION COIL CONNECTOR

**INSPECTION OF DISTRIBUTOR**

1. DISCONNECT DISTRIBUTOR CONNECTOR
2. REMOVE DISTRIBUTOR CAP
3. REMOVE ROTOR

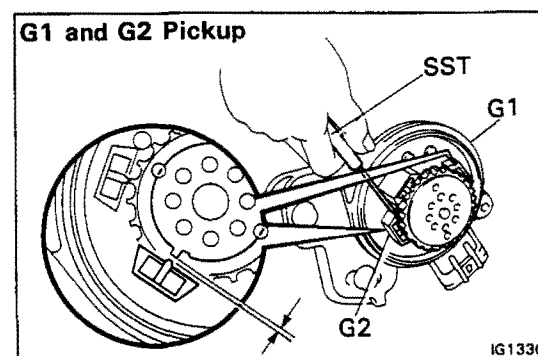
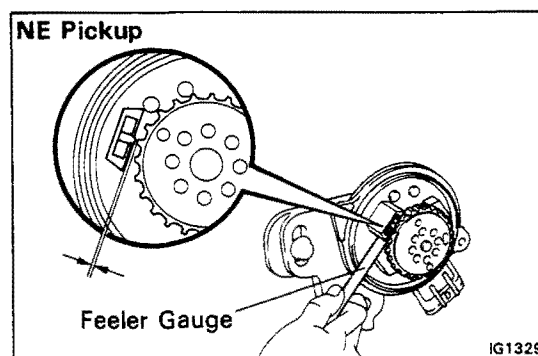
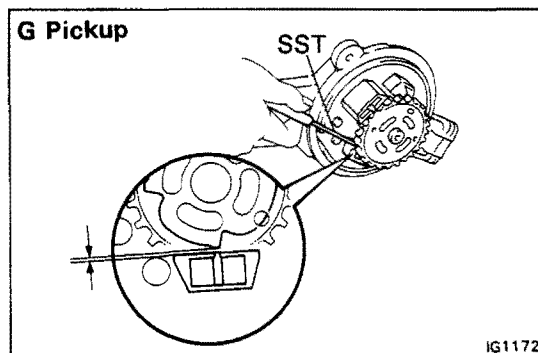
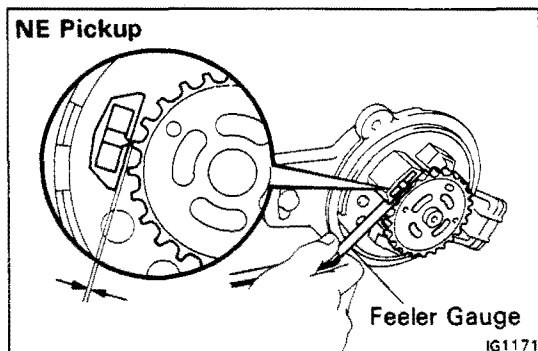

4. **INSPECT AIR GAP**  
**(5S-FE)**

Using SST (G pickup) and a feeler gauge (NE pickup), measure the air gap between the signal rotor and pickup coil projection.

SST 09240-00020 for G pickup

**Air gap: 0.2 – 0.4 mm (0.008 – 0.016 in.)**

If the air gap is not as specified, replace the distributor housing assembly.

4. **INSPECT AIR GAP**  
**(3S-GE, 3S-GTE)**

Using SST (G1 and G2 pickup) and a feeler gauge (NE pickup), measure the air gap between the signal rotor and pickup coil projection.

SST 09240-00020 for G1 and G2 pickup

**Air gap: 0.2 – 0.4 mm (0.008 – 0.016 in.)**

If the air gap is not as specified, replace the distributor housing assembly.

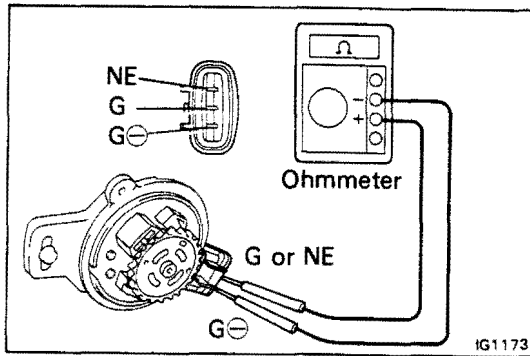

### 5. INSPECT SIGNAL GENERATOR (PICKUP COIL) RESISTANCE

**(5S-FE)**

Using an ohmmeter, measure the resistance between terminals (G and G ⊖ , NE and G ⊖ ).

**Pickup coil resistance (Cold): 170 – 210 Ω**

If the resistance is not as specified, replace the distributor housing assembly.

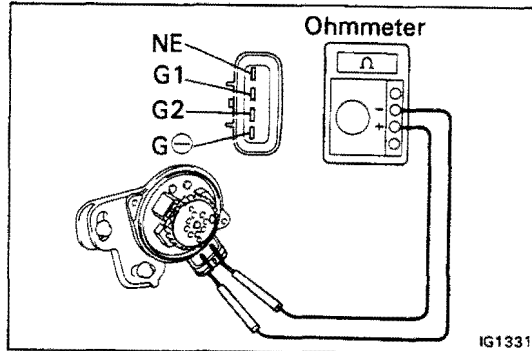

**(3S-GE, 3S-GTE)**

Using an ohmmeter, measure the resistance between terminals.

**Pickup coil resistance (Cold):**

**G1 to G ⊖ 140 – 180 Ω**

**G2 to G ⊖ 140 – 180 Ω**

**NE to G ⊖ 180 – 220 Ω**

If the resistance is not as specified, replace the distributor housing assembly.

### 6. REINSTALL ROTOR

### 7. REINSTALL DISTRIBUTOR CAP

### 8. RECONNECT DISTRIBUTOR CONNECTOR

## IGNITER

(See procedure Spark Test on page IG-5)



## DISTRIBUTOR COMPONENTS

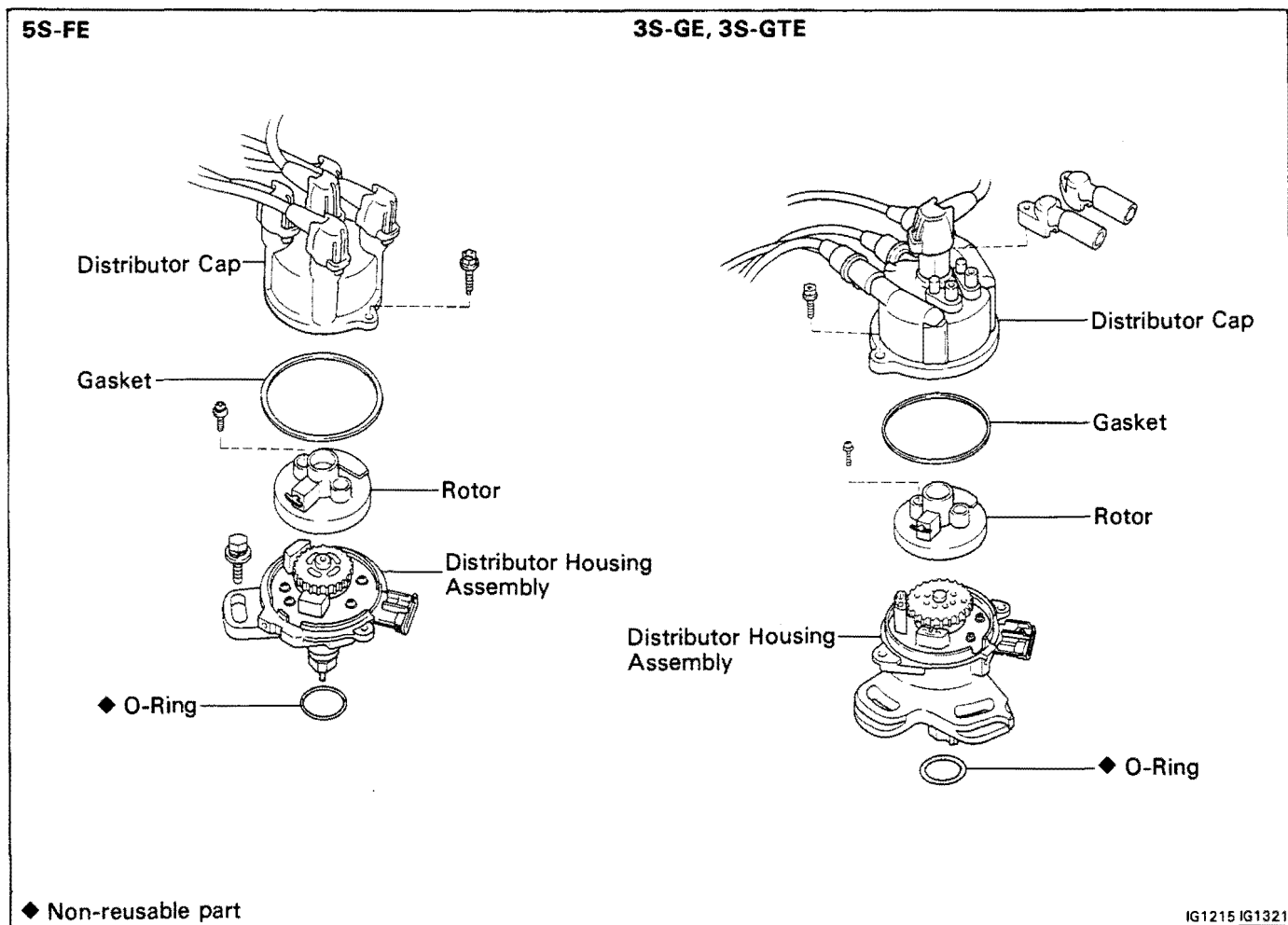

### REMOVAL OF DISTRIBUTOR

1. DISCONNECT DISTRIBUTOR CONNECTOR
2. DISCONNECT HIGH-TENSION CORDS

3. REMOVE DISTRIBUTOR

- (a) Remove the two hold-down bolt(s), and pull out the distributor.
- (b) Remove the O-ring from the distributor housing.

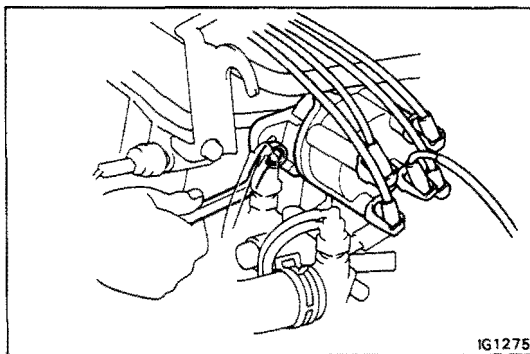

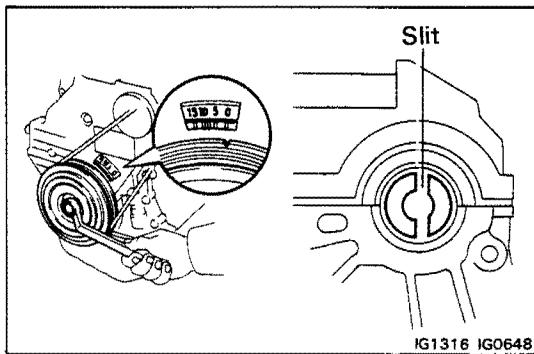

## INSTALLATION OF DISTRIBUTOR

### 1. SET NO.1 CYLINDER TO TDC/COMPRESSION

Turn the crankshaft clockwise, and position the slit of the intake camshaft as shown.

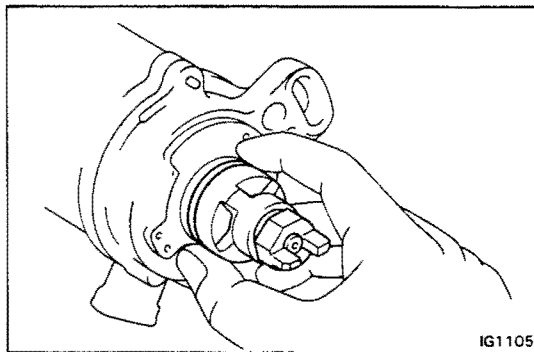

### 2. INSTALL DISTRIBUTOR

- (a) Install a new O-ring to the housing.
- (b) Apply a light coat of engine oil on the O-ring.

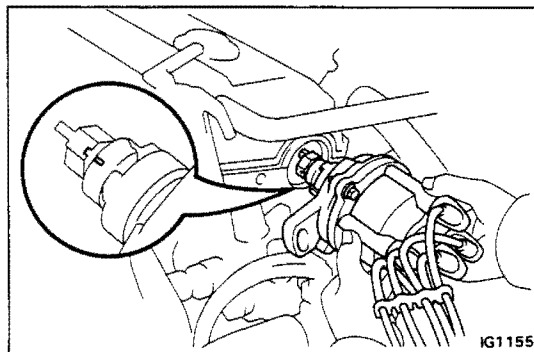

- (c) Align the cutout portion of the coupling with the groove of the housing.
- (d) Insert the distributor, aligning the center of the flange with that of the bolt hole on the cylinder head.
- (e) Lightly tighten the hold-down bolt(s).

### 3. CONNECT HIGH-TENSION CORDS

Firing order: 1 - 3 - 4 - 2

### 4. CONNECT DISTRIBUTOR CONNECTOR

### 5. ADJUST IGNITION TIMING (See pages EM-22, 23)

---

# STARTING SYSTEM

	Page
TROUBLESHOOTING .....	ST-2
STARTING SYSTEM CIRCUIT .....	ST-2
STARTER .....	ST-3

**ST**

## TROUBLESHOOTING

Problem	Possible cause	Remedy	Page
Engine will not crank	Battery charge low	Check battery specific gravity Check or replace battery	CH-3
	Battery cables loose, corroded or worn Neutral start switch faulty (A/T) Fusible link blown Starter faulty Ignition switch faulty	Repair or replace cables Adjust or repair switch Replace fusible link Repair starter Replace ignition switch	ST-3
Engine cranks slowly	Battery charge low	Check battery specific gravity Charge or replace battery	CH-3
	Battery cables loose, corroded or worn Starter faulty	Repair or replace cables Repair starter	ST-3
Starter keeps running	Starter faulty Ignition switch faulty Short in wiring	Repair starter Replace ignition switch Repair wiring	ST-3
Starter spins-engine will not crank	Pinion gear teeth broken or starter faulty Flywheel teeth broken	Repair starter Replace flywheel	ST-3

## STARTING SYSTEM CIRCUIT

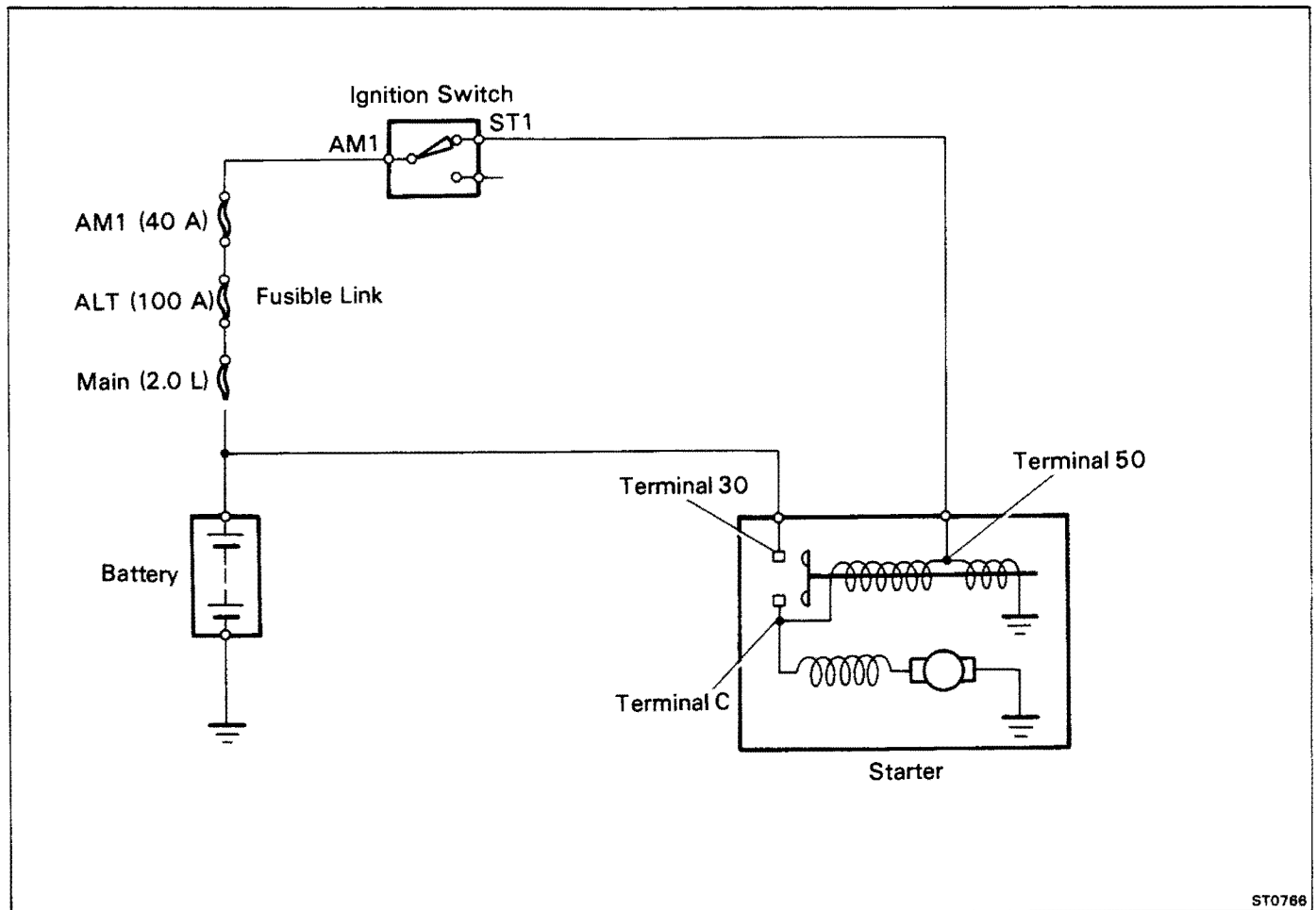

# STARTER COMPONENTS

## 1.0 kw Type

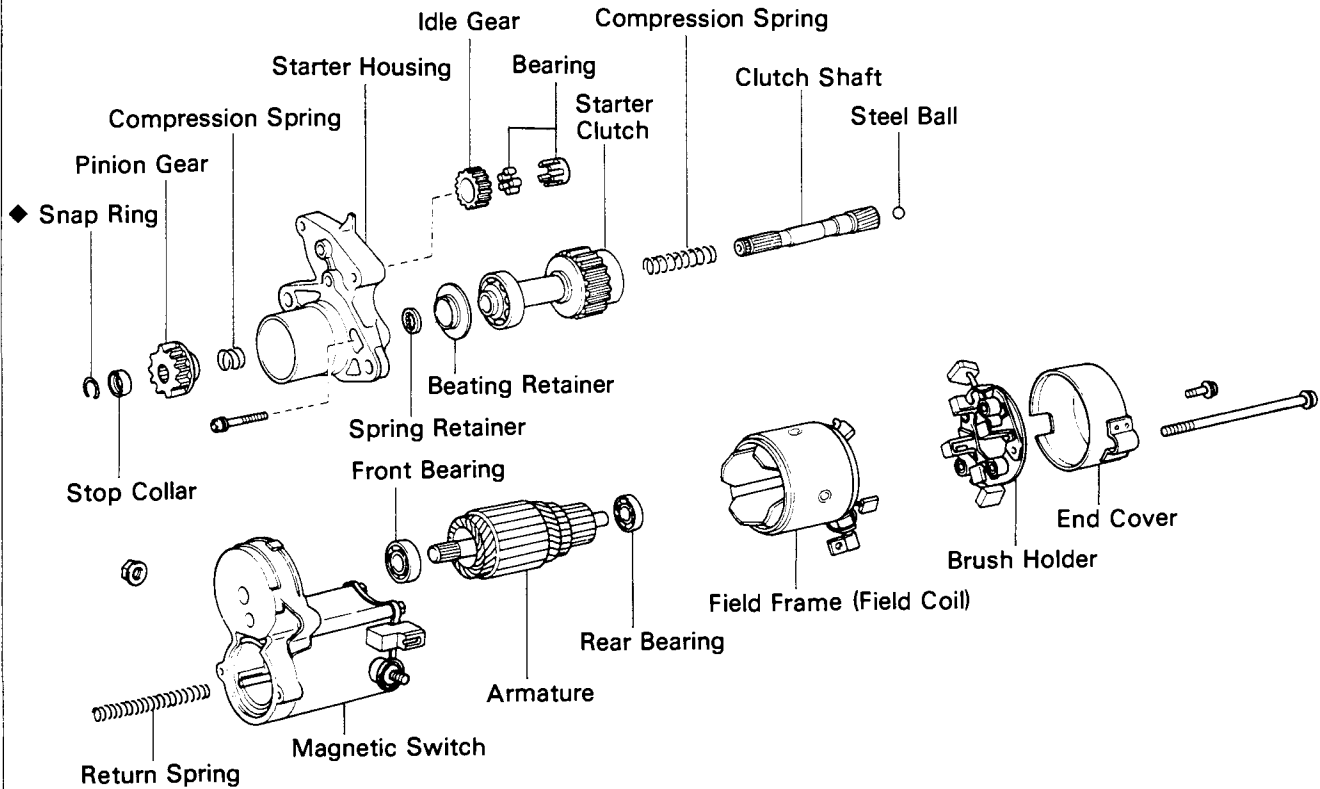

## 1.4 kw Type

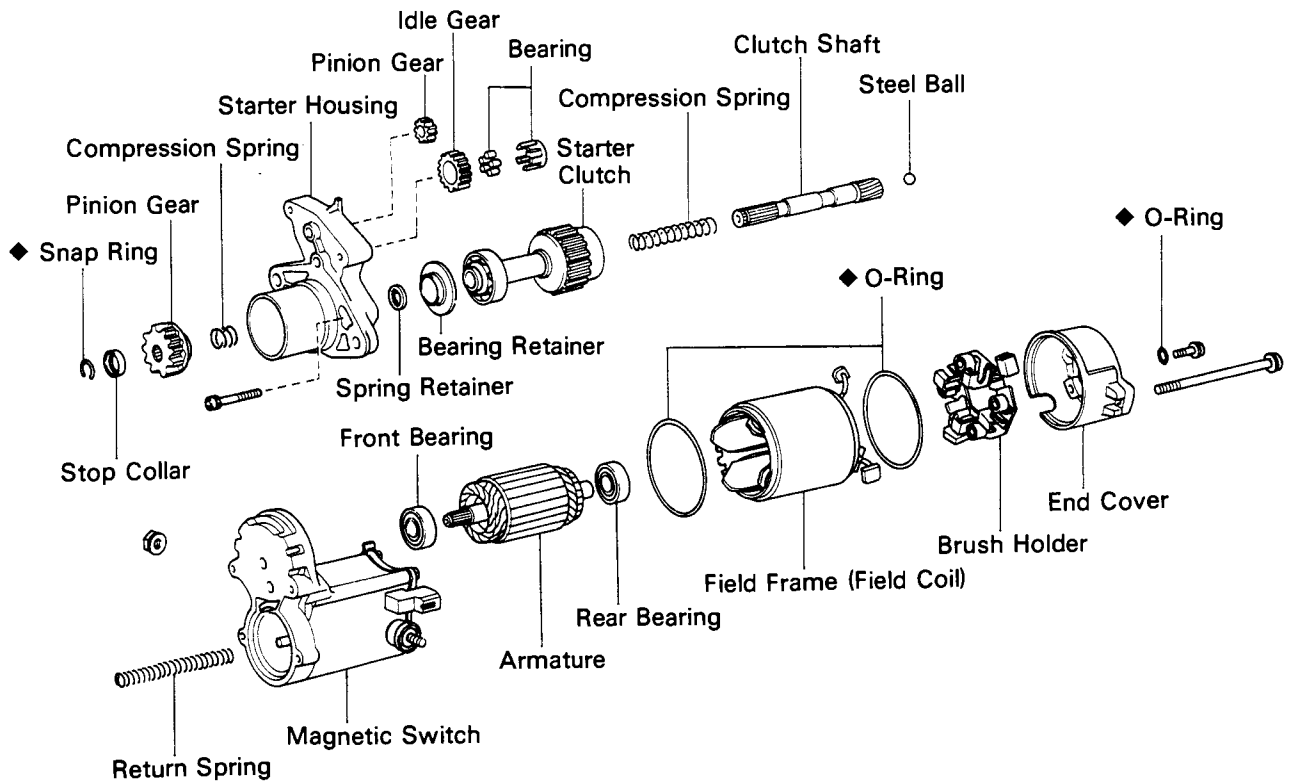

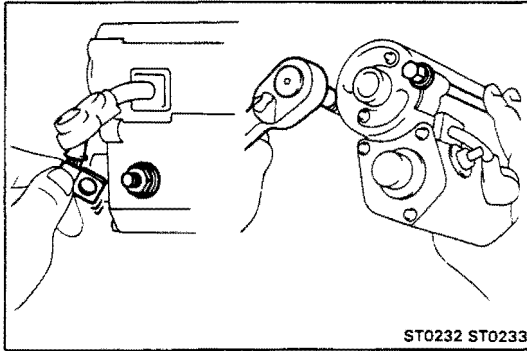

## DISASSEMBLY OF STARTER

(See page ST-3)

### 1. REMOVE FIELD FRAME AND ARMATURE

- (a) Remove the nut, and disconnect the lead wire from the magnetic switch terminal.
- (b) Remove the two through bolts, and pull out the field frame together with the armature.
- (c) (1.4 kw Type)  
Remove the O-ring.

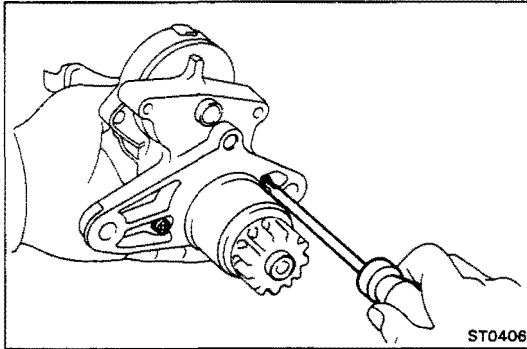

### 2. REMOVE STARTER HOUSING, CLUTCH ASSEMBLY AND GEARS

- (a) Remove the two screws.

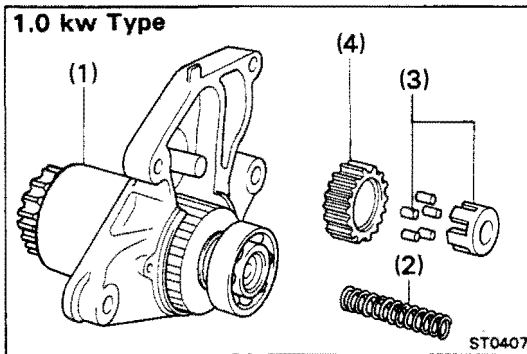

- (b) Remove the following parts from the magnetic switch:

(1.0 kw Type)

- (1) Starter housing and clutch assembly
- (2) Return spring
- (3) Bearing
- (4) Idle gear

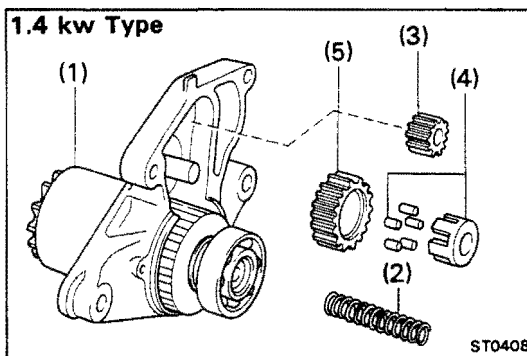

(1.4 kw Type)

- (1) Starter housing and clutch assembly
- (2) Return spring
- (3) Pinion gear
- (4) Bearing
- (5) Idler gear

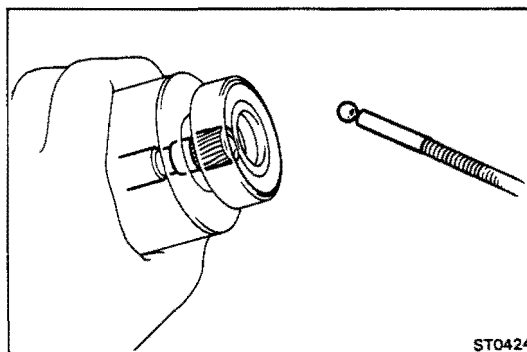

### 3. REMOVE STEEL BALL

Using a magnetic finger, remove the steel ball from the clutch shaft hole.

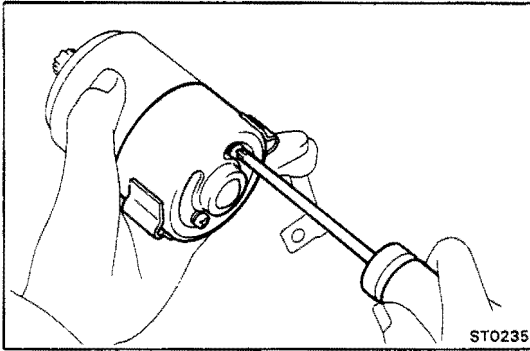

#### 4. REMOVE BRUSH HOLDER

- (a) Remove the two screws and end cover from the field frame.
- (b) (1.4 kw Type)  
Remove the O-ring

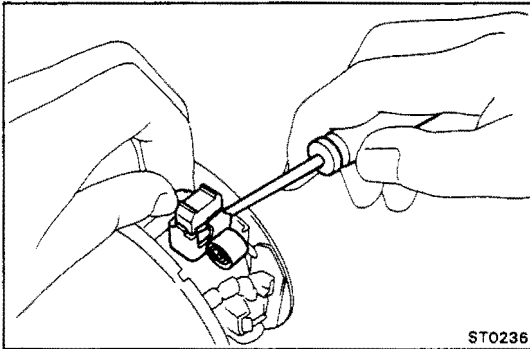

- (c) Using a screwdriver, hold the spring back and disconnect the brush from the brush holder. Disconnect the four brushes, and remove the brush holder.

#### 5. REMOVE ARMATURE FROM FIELD FRAME

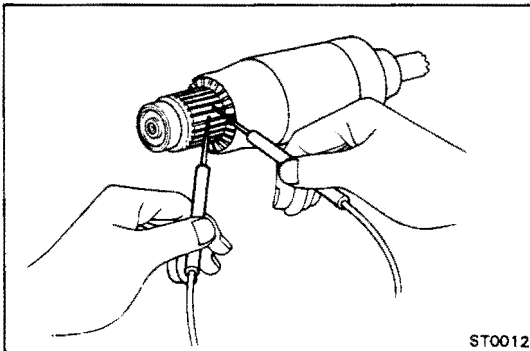

### INSPECTION AND REPAIR OF STARTER

#### Armature Coil

##### 1. INSPECT COMMUTATOR FOR OPEN CIRCUIT

Using an ohmmeter, check that there is continuity between the segments of the commutator.

If there is no continuity, replace the armature.

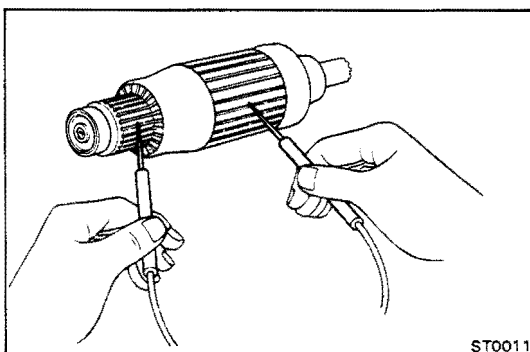

##### 2. INSPECT COMMUTATOR FOR GROUND

Using an ohmmeter, check that there is no continuity between the commutator and armature coil core.

If there is continuity, replace the armature.

#### Commutator

##### 1. INSPECT COMMUTATOR FOR DIRTY AND BURNT SURFACE

If the surface is dirty or burnt, correct with sandpaper (No. 400) or on a lathe.

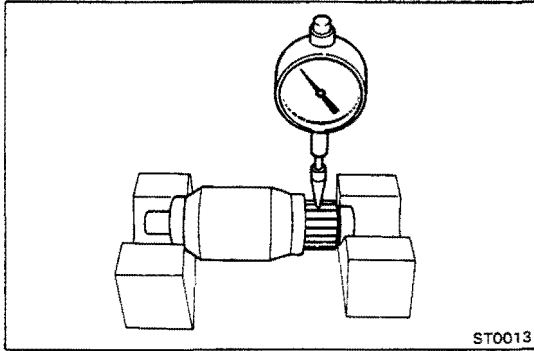

## 2. INSPECT COMMUTATOR FOR RUNOUT

- (a) Place the commutator on V-blocks.
- (b) Using a dial indicator, measure the circuit runout.

**Maximum circuit runout: 0.05 mm (0.0020 in.)**

If the circuit runout is greater than maximum, correct it on a lathe.

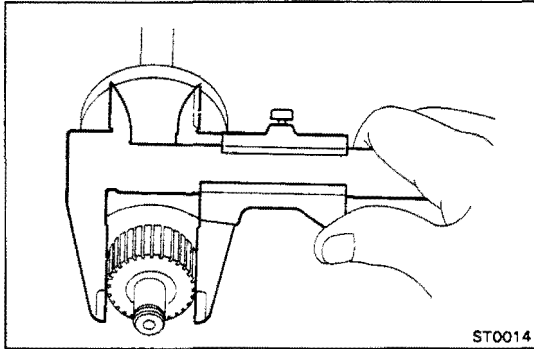

## 3. INSPECT COMMUTATOR DIAMETER

Using calipers, measure the diameter.

**Standard diameter: 30.0 mm (1.142 in.)**

**Minimum diameter: 29.0 mm (1.181 in.)**

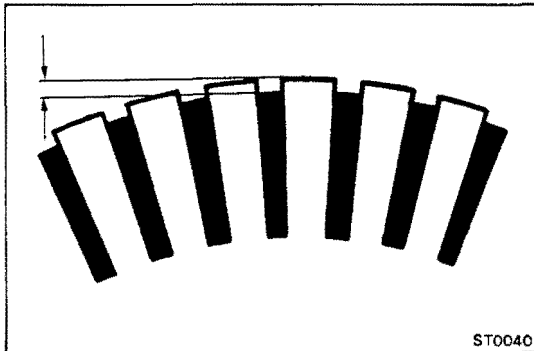

## 4. INSPECT UNDERCUT DEPTH

Check that the undercut depth is clean and free of foreign material. Smooth out the edges.

**Standard undercut depth: 0.6 mm (0.024 in.)**

**Minimum undercut depth: 0.2 mm (0.008 in.)**

If the undercut depth is less than minimum, correct it with a hacksaw blade.

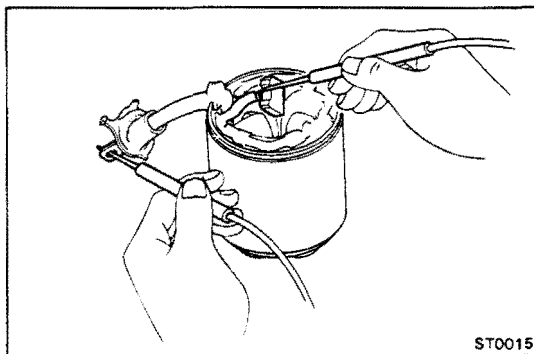

## Field Coil (Field Frame)

### 1. INSPECT FIELD COIL FOR OPEN CIRCUIT

Using an ohmmeter, check that there is continuity between the lead wire and field coil brush lead.

If there is no continuity, replace the field frame.

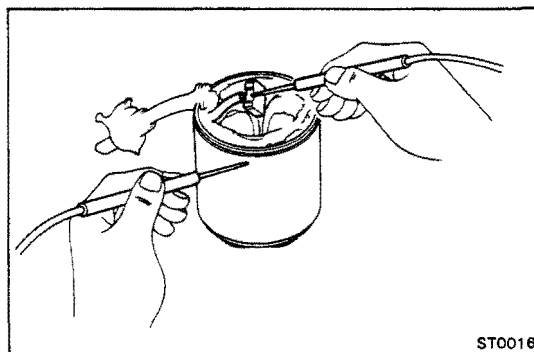

### 2. INSPECT FIELD COIL FOR GROUND

Using an ohmmeter, check that there is no continuity between the field coil end and field frame.

If there is continuity, replace the field frame.



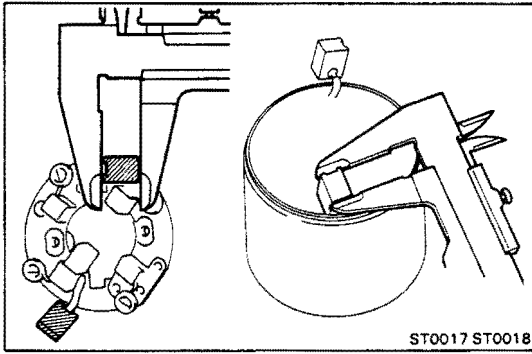

## Brushes

### INSPECT BRUSH LENGTH

Using calipers, measure the brush length.

#### Standard length:

1.0 kw type 13.5 mm (0.531 in.)

1.4 kw type 15.5 mm (0.610 in.)

#### Minimum length:

1.0 kw type 8.5 mm (0.335 in.)

1.4 kw type 10.0 mm (0.394 in.)

If the length is less than minimum, replace the brush holder and field frame.

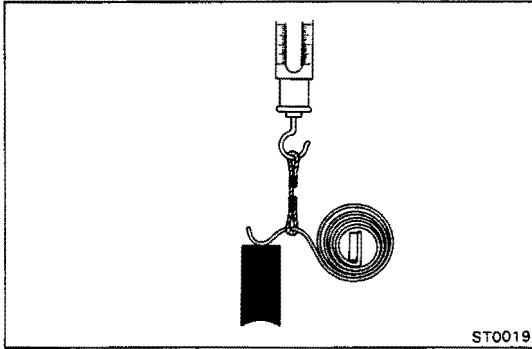

## Brush Springs

### INSPECT BRUSH SPRING LOAD

Take the pull scale reading the instant the brush spring separates from the brush.

#### Standard installed load:

1.79 – 2.41 kg (3.9 – 5.3 lb, 18 – 24 N)

If the installed load is not as specified, replace the brush springs.

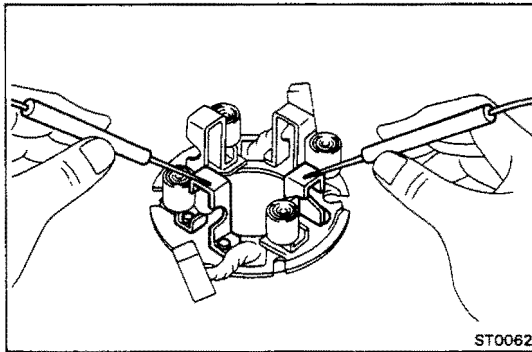

## Brush Holder

### INSPECT BRUSH HOLDER INSULATION

Using an ohmmeter, check that there is no continuity between the positive (+) and negative (-) brush holders.

If there is continuity, repair or replace the brush holder.

## Clutch and Gears

### 1. INSPECT GEAR TEETH

Check the gear teeth on the pinion gear, idler gear and the clutch assembly for wear or damage.

If damaged, replace the gear or clutch assembly.

If damaged, also check the flywheel ring gear for wear or damage.

### 2. INSPECT CLUTCH PINION GEAR

Rotate the pinion gear counterclockwise and check that it turns freely. Try to rotate the pinion gear clockwise and check that it locks.

If necessary, replace the clutch assembly.

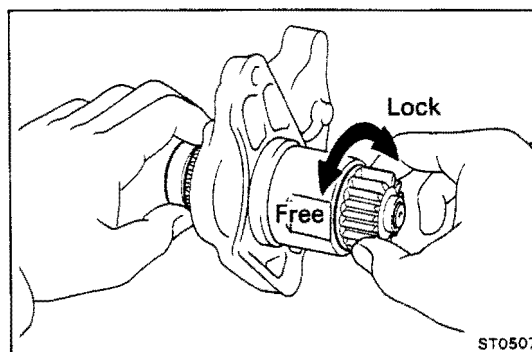

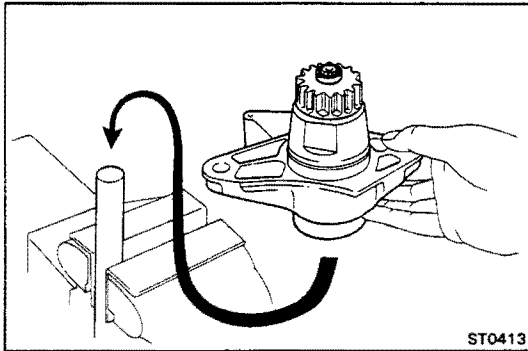

ST0413

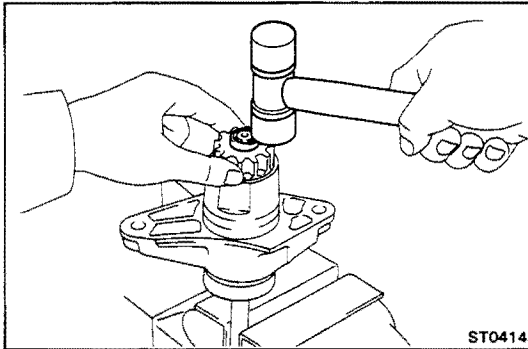

ST0414

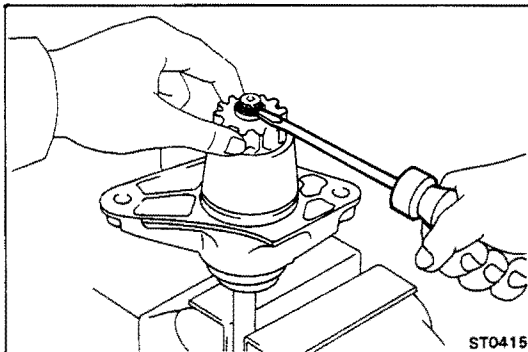

ST0415

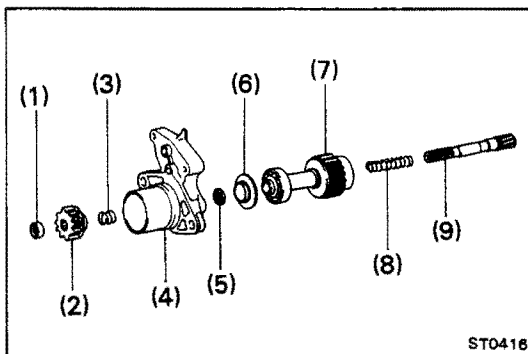

ST0416

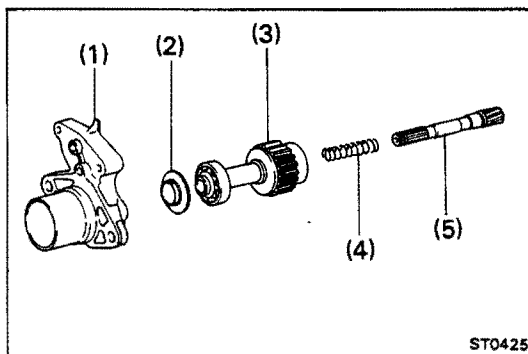

ST0425

### 3. IF NECESSARY, REPLACE CLUTCH ASSEMBLY

#### A. Disassembly starter housing and clutch assembly

- (a) Mount a brass bar in a vise, and install the starter housing and clutch assembly to the brass bar.

- (b) Push down the pinion gear.

- (c) Using a plastic faced hammer, tap in the stop collar.

- (d) Using a screwdriver, pry out the snap ring.

- (e) Disassemble the following parts:

- (1) Stop collar
- (2) Pinion gear
- (3) Compression spring
- (4) Starter housing
- (5) Spring retainer
- (6) Bearing retainer
- (7) Starter clutch
- (8) Compression spring
- (9) Clutch shaft

#### B. Assemble starter housing and clutch assembly

- (a) Assemble the following part:

- (1) Starter housing
- (2) Bearing retainer
- (3) Starter clutch
- (4) Compression spring
- (5) Clutch shaft

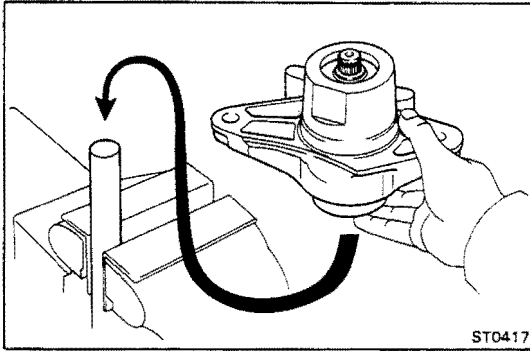

- (b) Mount a brass bar in a vise, install the starter housing and clutch assembly to the brass bar.

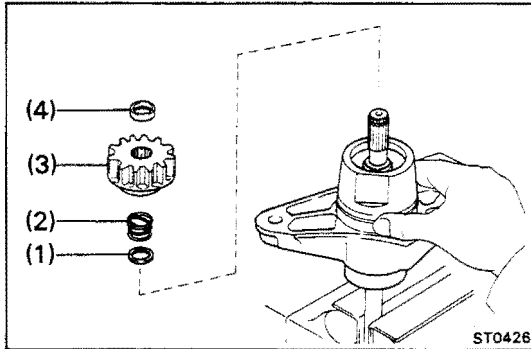

- (c) Push down the starter housing, and install the following parts:

- (1) Spring retainer
- (2) Compression spring
- (3) Pinion gear
- (4) Stop collar

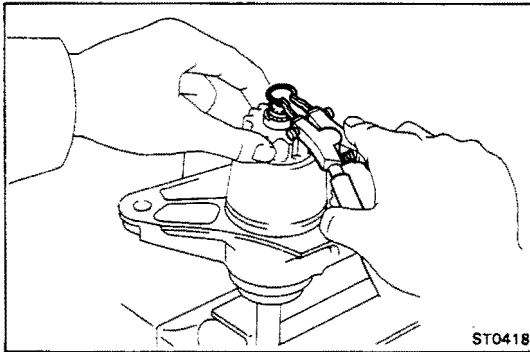

- (d) Push down the pinion gear.

- (e) Using snap ring pliers, install a new snap ring.

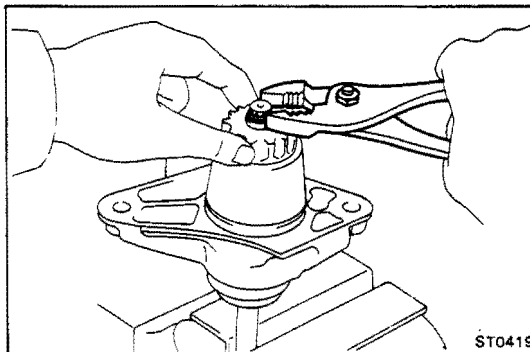

- (f) Using pliers, compress the snap ring.

- (g) Check that the snap ring fits correctly.

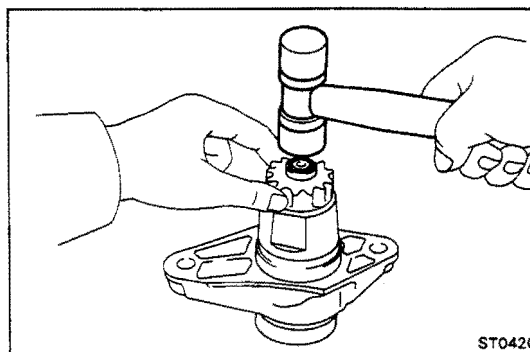

- (h) Remove the starter housing and clutch assembly from the brass bar.

- (i) Using a plastic faced hammer, tap the clutch shaft and install the stop collar onto the snap ring.

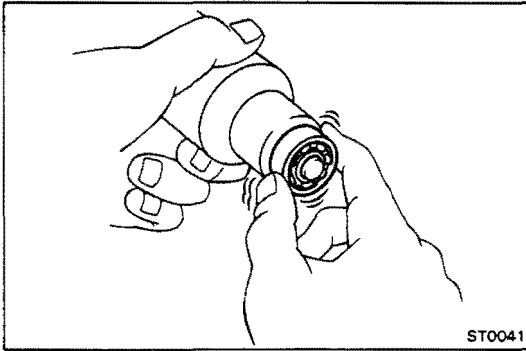

## Bearings

### 1. INSPECT BEARINGS

Turn each bearing by hand while applying pressure.

If resistance is felt or if the bearing sticks, replace the bearing.

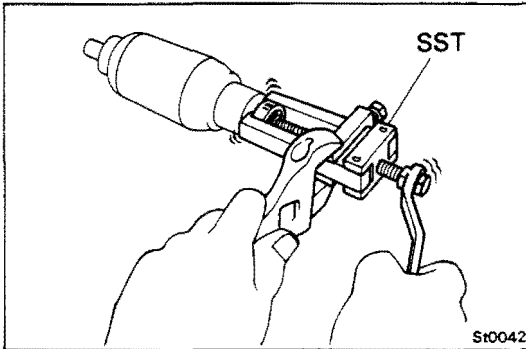

### 2. IF NECESSARY, REPLACE BEARINGS

(a) Using SST, remove the bearing.

SST 09286-46011

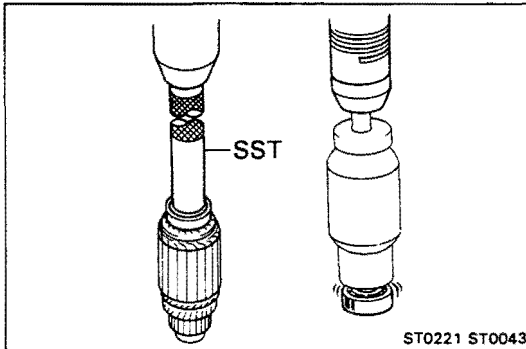

(b) Using SST and a press, press in a new front bearing.

SST 1.0 kw Type 09285-76010

1.4 kw Type 09201-41020

(c) Using a press, press in a new rear bearing

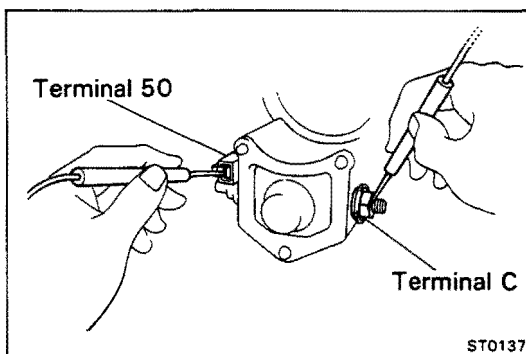

## Magnetic Switch

### 1. PERFORM PULL-IN COIL OPEN CIRCUIT TEST

Using an ohmmeter, check that there is continuity between terminals 50 and C.

If there is no continuity, replace the magnetic switch.

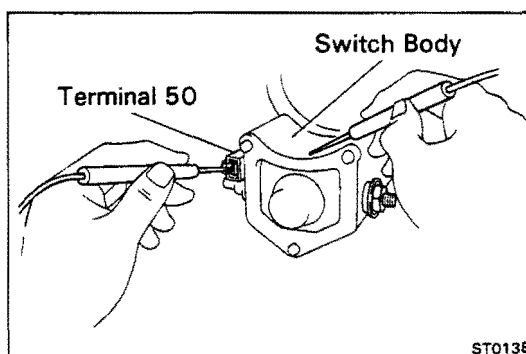

### 2. PERFORM HOLD-IN COIL OPEN CIRCUIT TEST

Using an ohmmeter, check that there is continuity between terminal 50 and the switch body.

If there is no continuity, replace the magnetic switch.

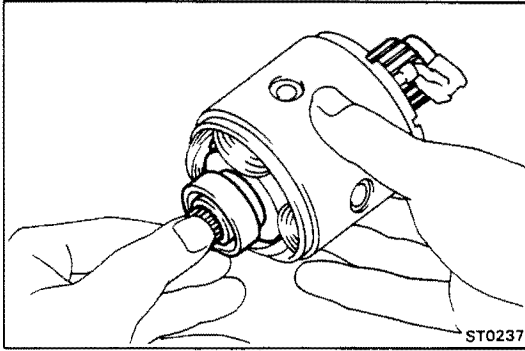

## ASSEMBLY OF STARTER

(See page ST-3)

HINT: Use high-temperature grease to lubricate the bearings and gears when assembling the starter.

### 1. PLACE ARMATURE INTO FIELD FRAME

Apply grease to the armature bearings, and insert the armature into the field frame.

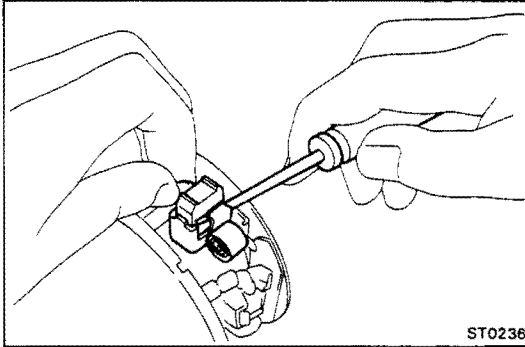

### 2. INSTALL BRUSH HOLDER

- (a) Place the brush holder in position on the armature.
- (b) Using a screwdriver, hold the brush spring back, and connect the brush into the brush holder. Connect the four brushes.

HINT: Check that the positive (+) lead wires are not grounded.

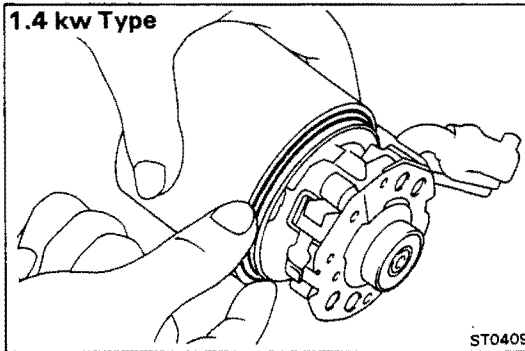

- (c) (1.4 kw Type)

Place a new O-ring in position on the field frame.

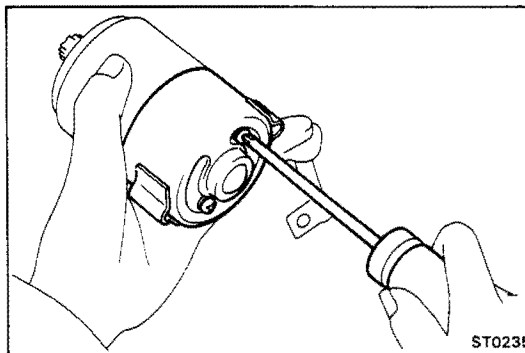

- (d) Install the end cover with the two screws.

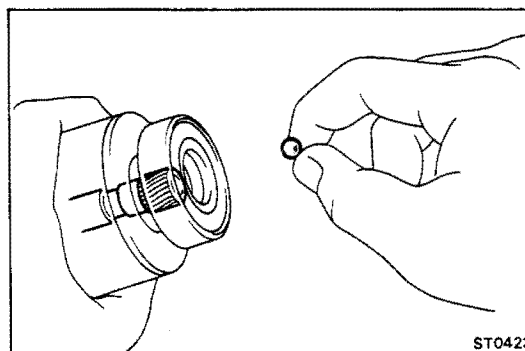

### 3. INSERT STEEL BALL INTO CLUTCH SHAFT HOLE

- (a) Apply grease to the steel ball.
- (b) Insert the steel ball into the clutch shaft hole.

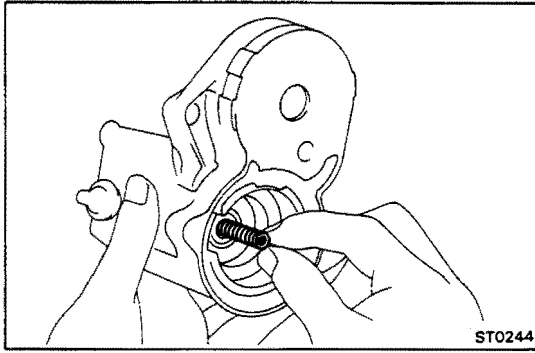

#### 4. INSTALL CLUTCH ASSEMBLY AND GEARS

- (a) Apply grease to the return spring.
- (b) Insert the return spring into the magnetic switch hole.

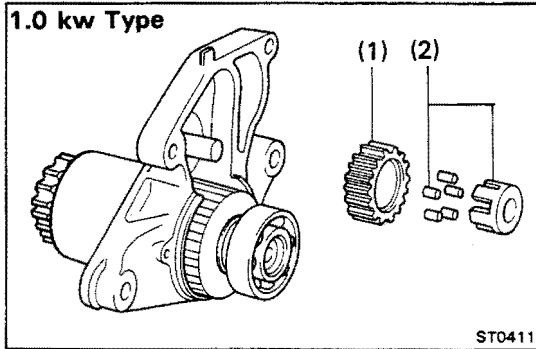

- (c) Place the following parts in position on the starter housing:

(1.0 kw Type)

(1) Idler gear

(2) Bearing

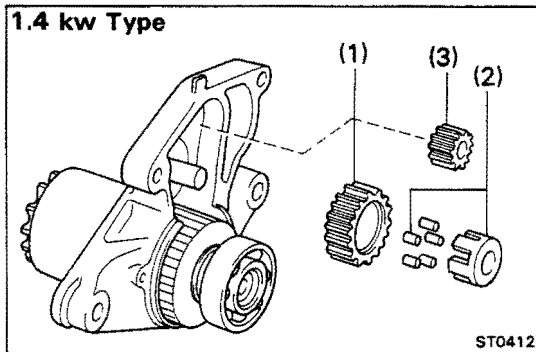

(1.4 kw type)

(1) Idler gear

(2) Bearing

(3) Pinion gear

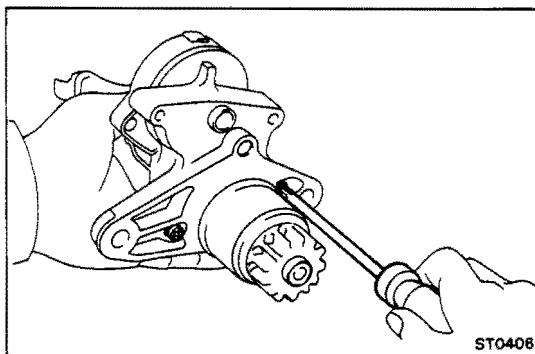

- (d) Assemble the starter housing and magnetic switch with the two screws.

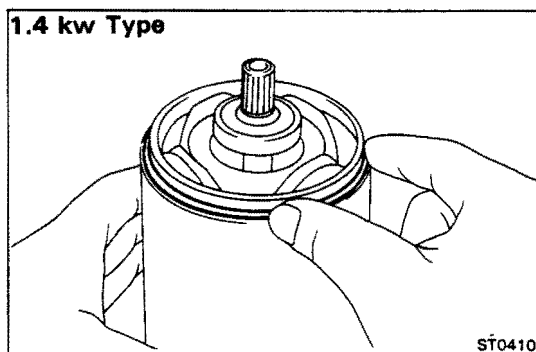

#### 5. INSTALL FIELD FRAME AND ARMATURE ASSEMBLY

- (a) (1.4 kw Type)

Place a new O-ring in position on the field frame.

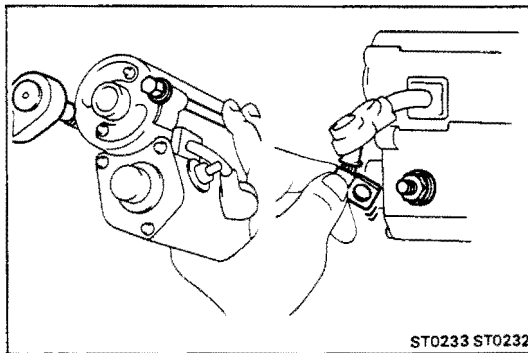
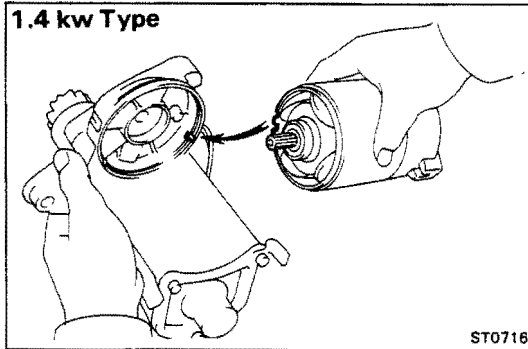
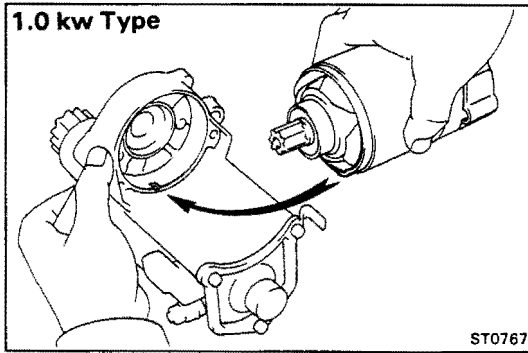

(b) Align the protrusion of the field frame with the cutout of the magnetic switch.

(c) Install the field frame and armature assembly with the two through bolts.

(d) Connect the lead wire to terminal C, and install the nut.

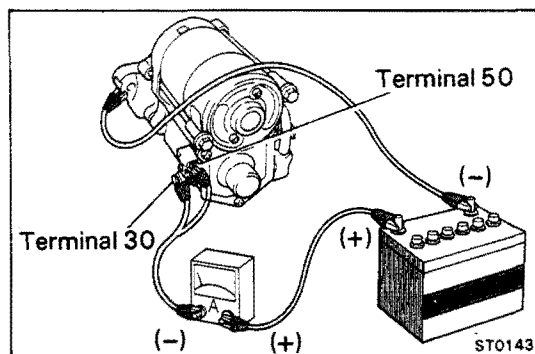
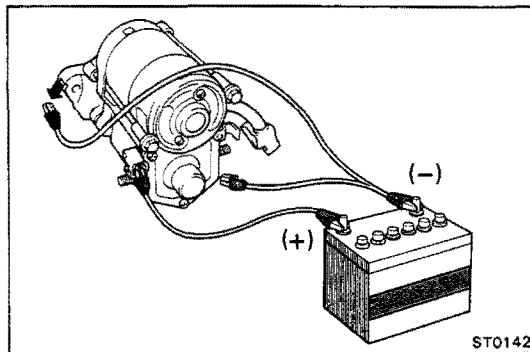
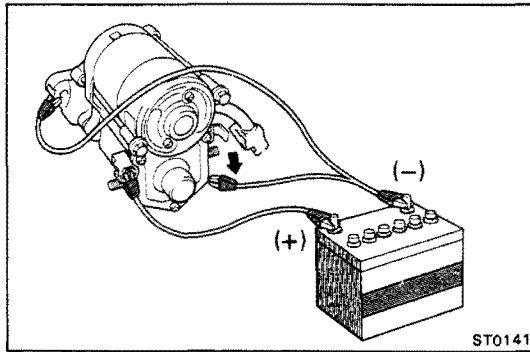
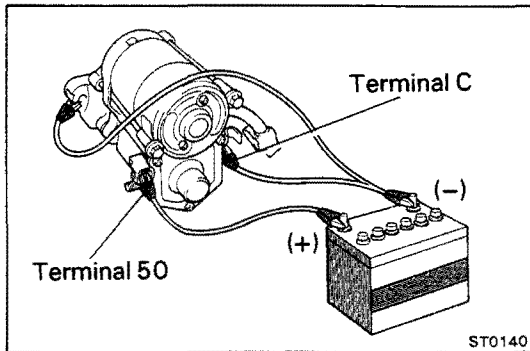

## PERFORMANCE TEST OF STARTER

**NOTICE:** These tests must be performed within 3 to 5 seconds to avoid burning out the coil.

### 1. PERFORM PULL-IN TEST

- Disconnect the field coil lead wire from terminal C.
- Connect battery to the magnetic switch as shown. Check that the pinion gear moves outward.

If the pinion gear does not move, replace the magnetic switch.

### 2. PERFORM HOLD-IN TEST

While connected as above with the pinion gear out, disconnect the negative (-) lead from terminal C. Check that the pinion gear remains out.

If the pinion gear returns inward, replace the magnetic switch.

### 3. INSPECT PLUNGER RETURN

Disconnect the negative (-) lead from the switch body. Check that the pinion gear returns inward.

If the pinion gear does not return, replace the magnetic switch.

### 4. PERFORM NO-LOAD PERFORMANCE TEST

- Connect battery and ammeter to the starter as shown.
- Check that the starter rotates smoothly and steadily with the pinion gear moving out. Check the reading on the ammeter.

**Standard amperage: 90 A or less at 11.5 V**



---

# CHARGING SYSTEM

	Page
PRECAUTIONS .....	CH-2
TROUBLESHOOTING .....	CH-2
CHARGING SYSTEM CIRCUIT .....	CH-2
ON-VEHICLE INSPECTION .....	CH-3
ALTERNATOR .....	CH-6

## PRECAUTIONS

1. Check that the battery cables are connected to the correct terminals.
2. Disconnect the battery cables when the battery is given a quick charge.
3. Do not perform tests with a high voltage insulation resistance tester.
4. Never disconnect the battery when the engine is running.

## TROUBLESHOOTING

Problem	Possible cause	Remedy	Page
Discharge warning light does not light with ignition ON and engine not running	Fuse blown	Check "CHARGE" and "IGN" fuses	CH-6
	Light burned out	Replace light	
	Wiring connections loose	Tighten loose connections	
	IC regulator faulty	Replace IC regulator	
Discharge warning light does not go out with engine running (battery requires frequent recharging)	Drive belt loose or worn	Adjust or replace drive belt	CH-3
	Battery cables loose, corroded or worn	Repair or replace cables	
	Fuse blown	Check "ECU-IG" fuse	
	Fusible link blown	Replace fusible link	CH-4
	IC regulator or alternator faulty	Check charging system	
	Wiring faulty	Repair wiring	

## CHARGING SYSTEM CIRCUIT

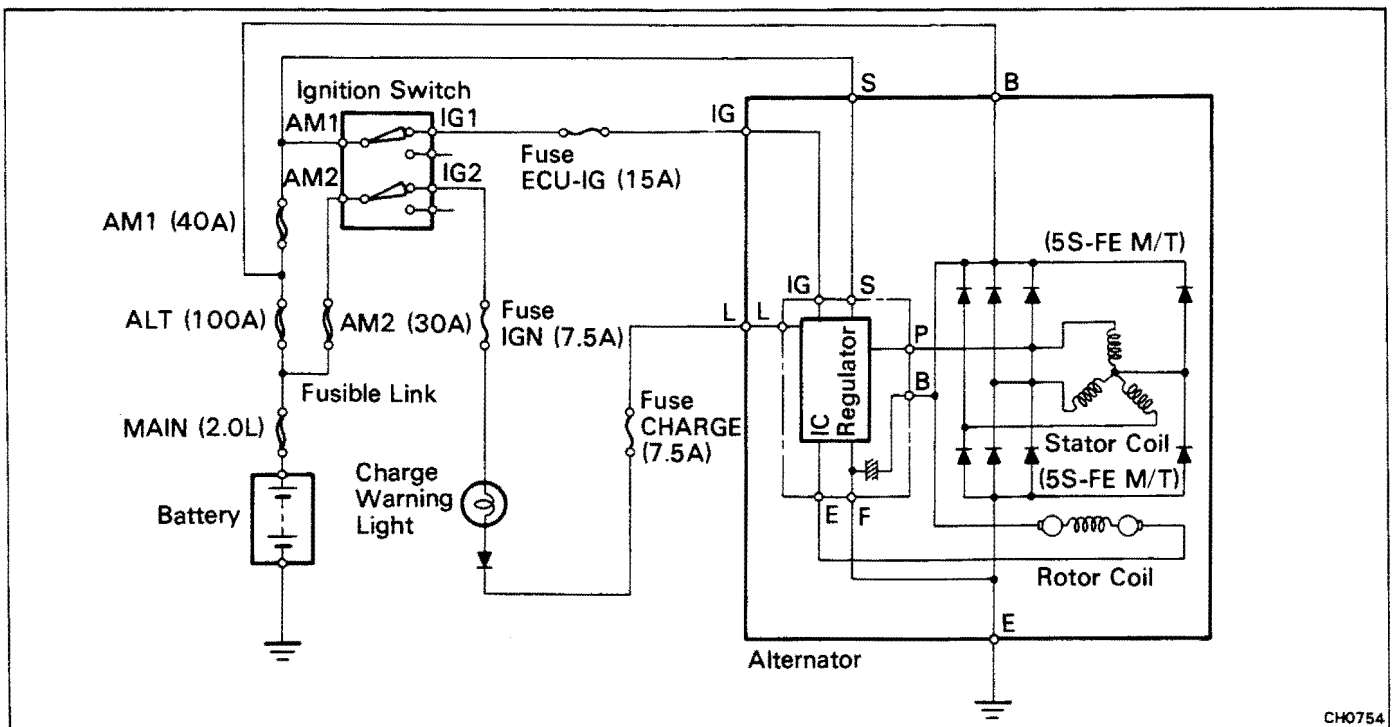

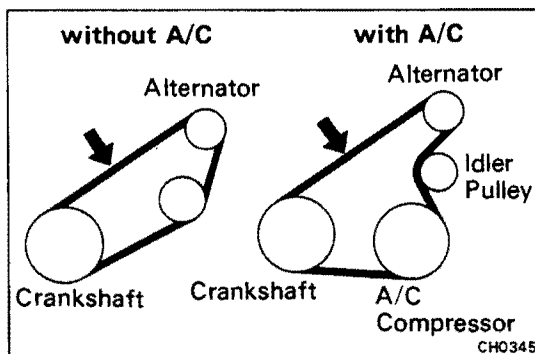
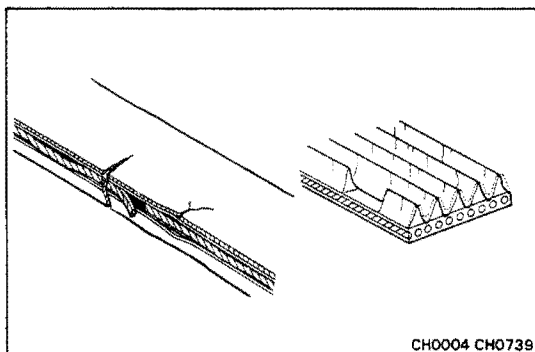
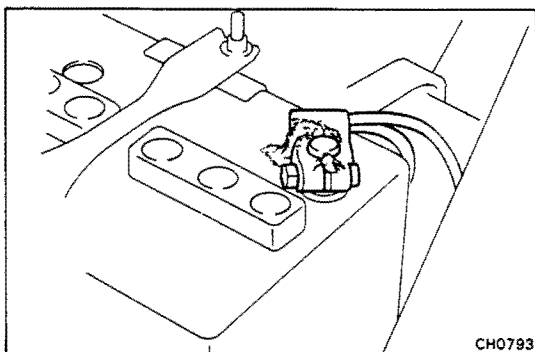
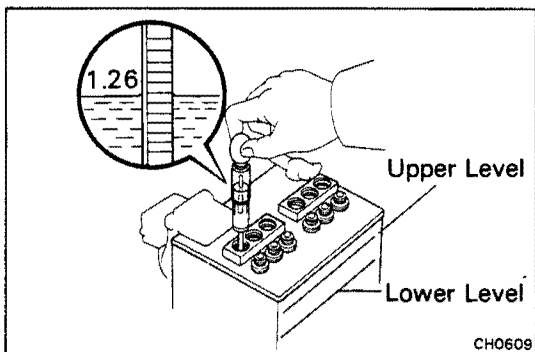

## ON-VEHICLE INSPECTION

### 1. INSPECT BATTERY SPECIFIC GRAVITY AND ELECTROLYTE LEVEL

(a) Check the specific gravity of each cell.

**Standard specific gravity:**

**1.25 – 1.27 when fully charged at 20°C (68°F)**

If not within specification, charge the battery.

(b) Check the electrolyte quantity of each cell.

If insufficient, refill with distilled (or purified) water.

### 2. CHECK BATTERY TERMINALS, FUSIBLE LINKS AND FUSES

(a) Check that the battery terminals are not loose or corroded.

(b) Check the fusible links and fuses for continuity.

<b>Fusible link:</b>	<b>MAIN</b>	<b>2.0 L</b>
	<b>ALT</b>	<b>100 A</b>
	<b>AM1</b>	<b>40 A</b>
	<b>AM2</b>	<b>30 A</b>
<b>Fuse:</b>	<b>ECU-IG</b>	<b>15 A</b>
	<b>IGN</b>	<b>7.5 A</b>

### 3. INSPECT DRIVE BELT

(a) Visually check the drive belt for excessive wear, frayed cords etc.

If necessary, replace the drive belt.

**HINT:** Cracks on ribbed side of a drive belt are considered acceptable. If the drive belt has chunks missing from the ribs, it should be replaced.

(b) Check the drive belt deflection by pressing on the belt at the points indicated in the illustration with 10 kg (22.0 lb, 98N) of pressure.

**Drive belt deflection:**

**without A/C**

<b>New belt</b>	
<b>5S-FE</b>	<b>11 – 15 mm</b> <b>(0.43 – 0.59 in.)</b>
<b>3S-GE, 3S-GTE</b>	<b>11 – 14 mm</b> <b>(0.43 – 0.55 in.)</b>

<b>Used belt</b>	
<b>5S-FE</b>	<b>13 – 17 mm</b> <b>(0.51 – 0.67 in.)</b>
<b>3S-GE, 3S-GTE</b>	<b>12 – 18 mm</b> <b>(0.47 – 0.71 in.)</b>

**with A/C**

<b>New belt</b>	
<b>5S-FE</b>	<b>6 – 9 mm</b> <b>(0.24 – 0.35 in.)</b>
<b>3S-GE, 3S-GTE</b>	<b>9 – 11 mm</b> <b>(0.35 – 0.43 in.)</b>

<b>Used belt</b>	
<b>5S-FE</b>	<b>9 – 11 mm</b> <b>(0.35 – 0.43 in.)</b>
<b>3S-GE, 3S-GTE</b>	<b>13 – 16 mm</b> <b>(0.51 – 0.63 in.)</b>

If necessary, adjust the drive belt deflection.

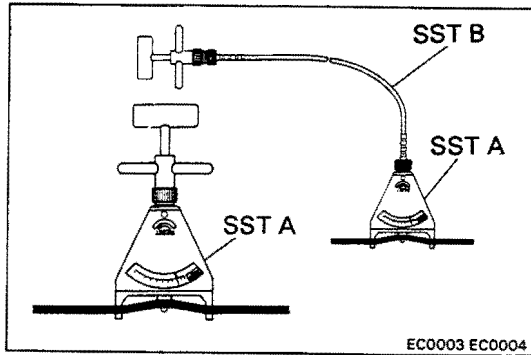
**[Reference]**

Using SST, check the drive belt tension.

SST A 09216-00020

SST B 09216-00030

**Drive belt tension:****without A/C****New belt**

5S-FE 45 – 55 kg

3S-GE, 3S-GTE 47 – 72 kg

**Used belt**

5S-FE 20 – 35 kg

3S-GE, 3S-GTE 36 – 62 kg

**with A/C****New belt**

5S-FE 70 – 80 kg

3S-GE, 3S-GTE 70 – 80 kg

**Used belt**

5S-FE 45 – 55 kg

3S-GE, 3S-GTE 30 – 45 kg

If the belt tension is not as specified, adjust it.

**HINT:**

- "New belt" refers to a belt which has been used 5 minutes or less on a running engine.
- "Used belt" refers to a belt which has been used on a running engine for 5 minutes or more.
- After installing a belt, check that it fits properly in the ribbed grooves.
- Check by hand to confirm that the belt has not slipped out of the groove on the bottom of the pulley.
- After installing a new belt, run the engine for about 5 minutes and recheck the belt tension.

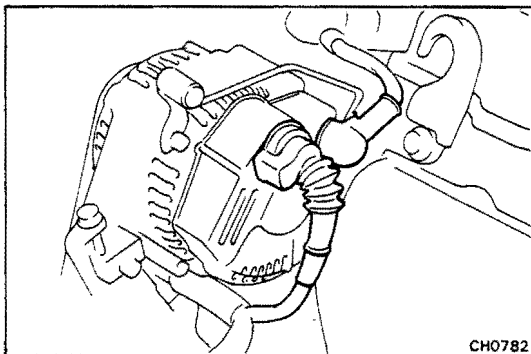
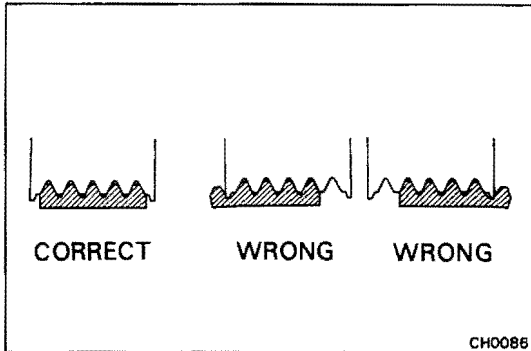

**4. VISUALLY CHECK ALTERNATOR WIRING AND LISTEN FOR ABNORMAL NOISES**

- (a) Check that the wiring is in good condition.
- (b) Check that there is no abnormal noise from the alternator while the engine is running.

**5. INSPECT CHARGE WARNING LIGHT CIRCUIT**

- (a) Warm up the engine and then turn it off.
- (b) Turn off all accessories.
- (c) Turn the ignition switch to "ON". Check that the charge warning light is lit.
- (d) Start the engine. Check that the light goes out.

If the light does not go off as specified, troubleshoot the charge light circuit.

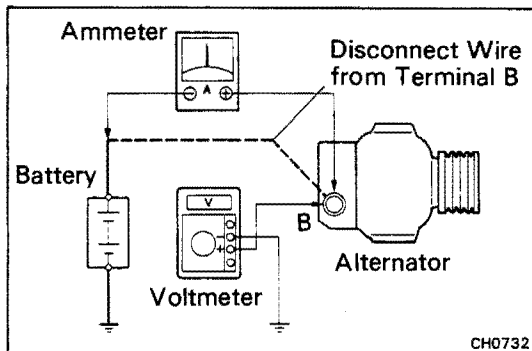

## 6. INSPECT CHARGING CIRCUIT WITHOUT LOAD

**HINT:** If a battery/alternator tester is available, connect the tester to the charging circuit as per manufacturer's instructions.

(a) If a tester is not available, connect a voltmeter and ammeter to the charging circuit as follows:

- Disconnect the wire from terminal B of the alternator and connect it to the negative (–) probe of the ammeter.
- Connect the positive (+) probe of the ammeter to terminals B of the alternator.
- Connect the positive (+) probe of the voltmeter to terminal B of the alternator.
- Ground the negative (–) probe of the voltmeter.

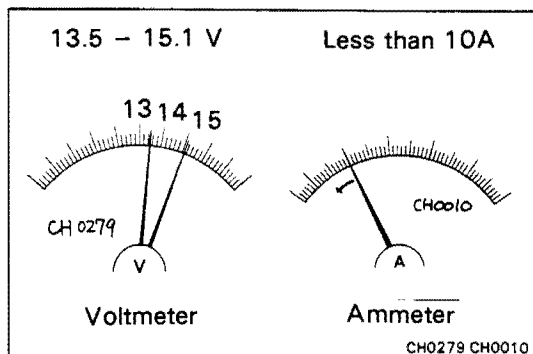

(b) Check the charging circuit as follows:

With the engine running from idling to 2,000 rpm, check the reading on the ammeter and voltmeter.

**Standard amperage:** Less than 10 A  
**Standard voltage:** 13.9 – 15.1 V at 25°C (77°F)  
 13.5 – 14.3 V at 115°C (239°F)

If the voltage reading is greater than standard voltage, replace the IC regulator.

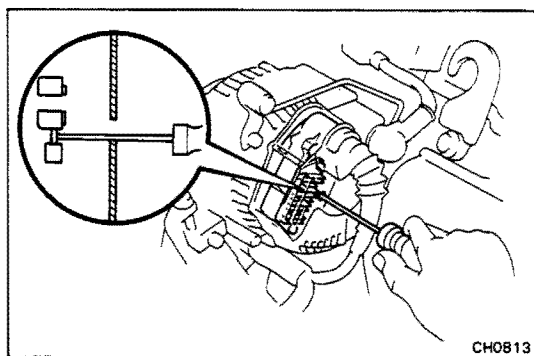

If the voltage reading is less than standard voltage, check the IC regulator and alternator as follows:

- With terminal F grounded, start the engine and check the voltage reading of terminal B.
- If the voltage reading is higher than standard voltage, replace the IC regulator.
- If the voltage reading is less than standard voltage, repair the alternator.

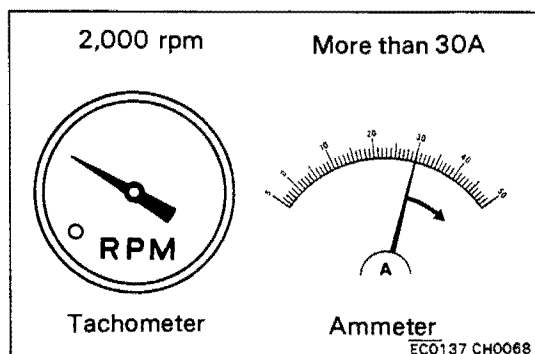

## 8. INSPECT CHARGING CIRCUIT WITH LOAD

(a) With the engine running at 2,000 rpm, turn ON the high beam headlights and place the heater fan control switch at HI.

(b) Check the reading on the ammeter.

**Standard amperage:** More than 30 A

If the ammeter reading is less than 30 A, repair the alternator. (See page CH-6)

**HINT:** If the battery is fully charged, the indication will sometimes be less than 30 A.

# ALTERNATOR COMPONENTS

## 5S-FE M/T

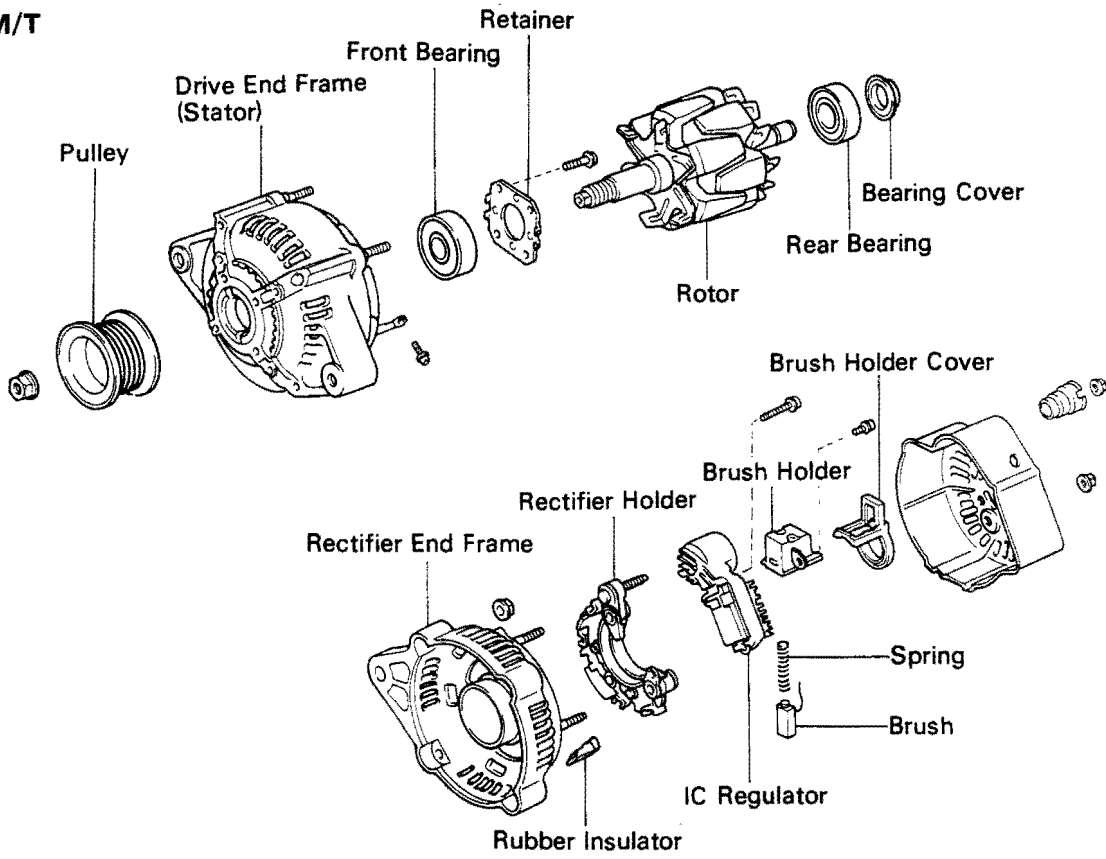

## Others

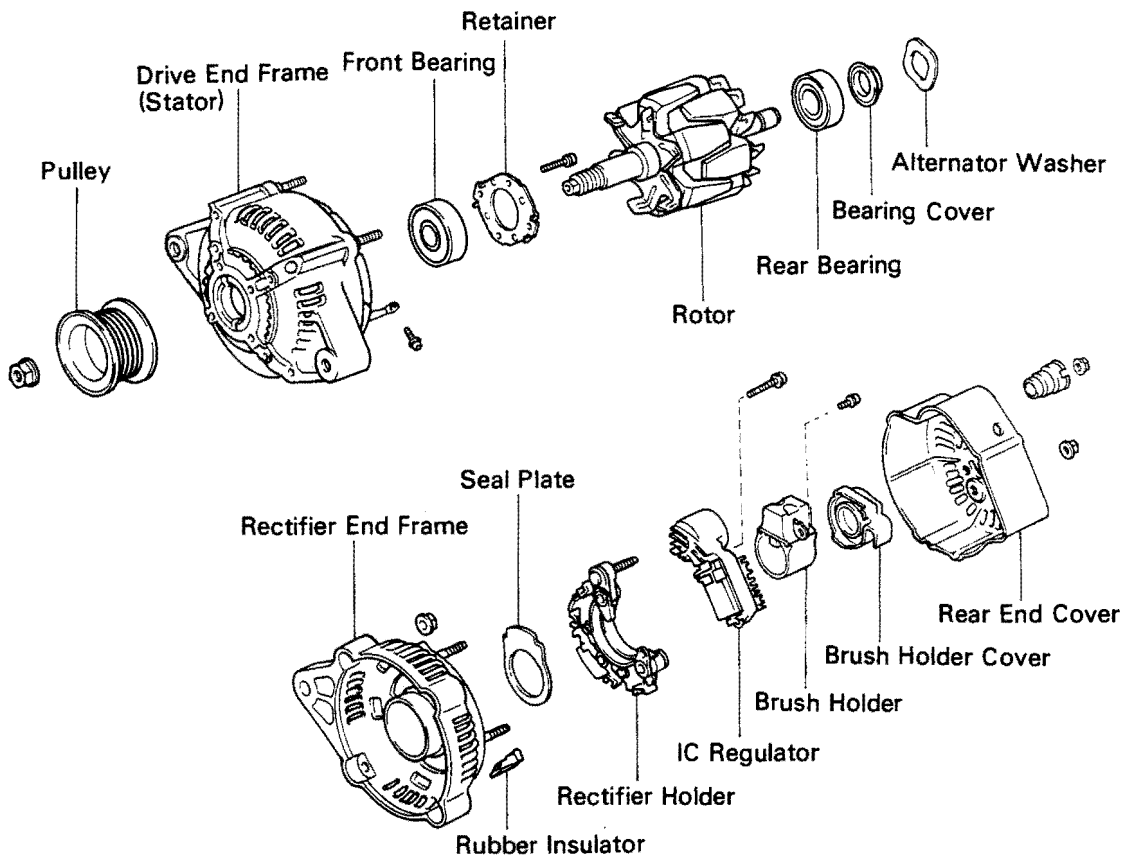

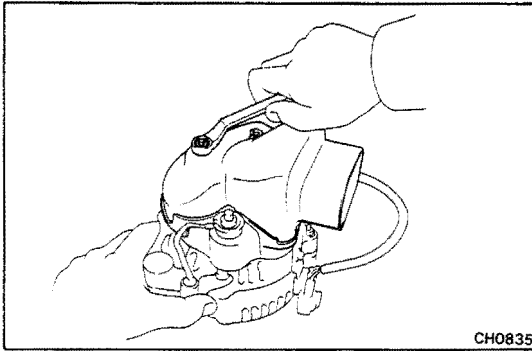

## DISASSEMBLY OF ALTERNATOR

(See page CH-6)

### 1. (3S-GTE) REMOVE AIR DUCT

Remove the bolt, two nuts and air duct, and remove the two bushings.

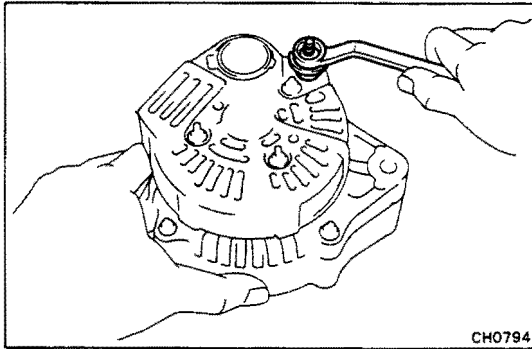

### 2. REMOVE REAR END COVER

(a) Remove the nut and terminal insulator.

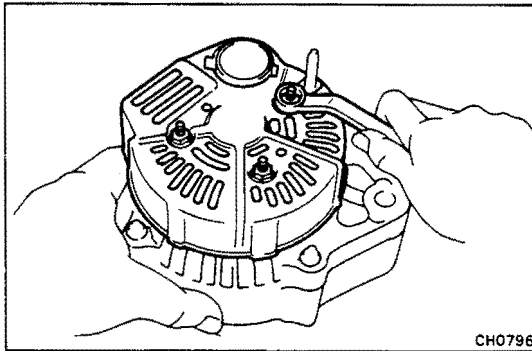

(b) Remove the three nuts and end cover.

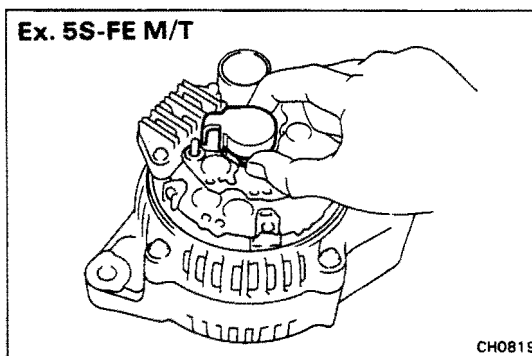

### 3. REMOVE BRUSH HOLDER AND IC REGULATOR

(a) (Ex. 5S-FE M/T)

Remove the brush holder cover from the brush holder.

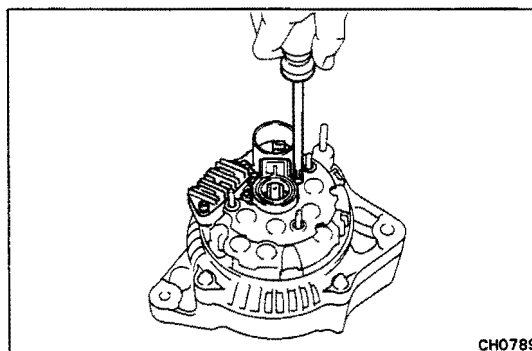

(b) Remove the five screws, brush holder and IC regulator.

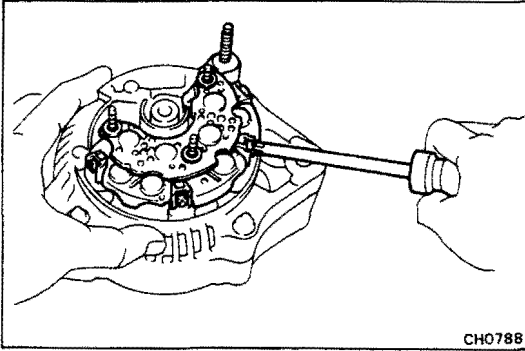

#### 4. REMOVE RECTIFIER HOLDER

- (a) Remove the four screws and rectifier holder.

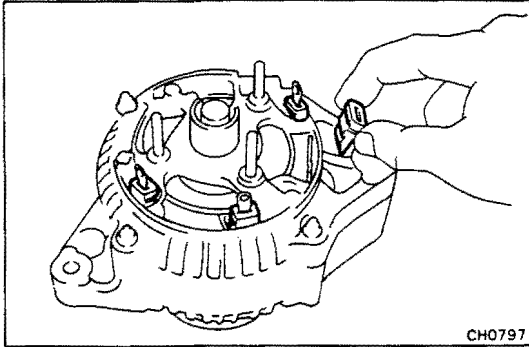

- (b) Remove the four rubber insulators.

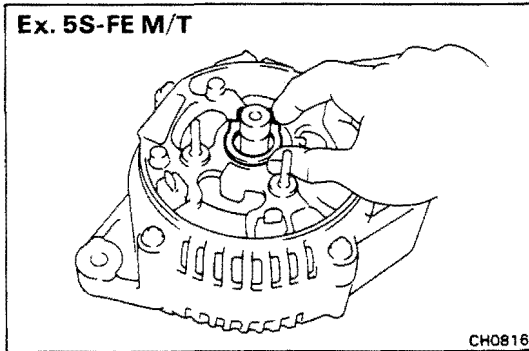

- (c) (Ex. 5S-FE M/T)  
Remove the seal plate.

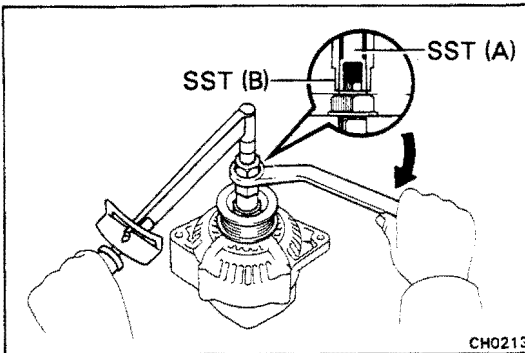

#### 5. REMOVE PULLEY

- (a) Hold SST (A) with a torque wrench, and tighten SST (B) clockwise to the specified torque.

SST 09820-63010

**Torque: 400 kg-cm (29 ft-lb, 39 N·m)**

- (b) Check that SST (A) is secured to the rotor shaft.

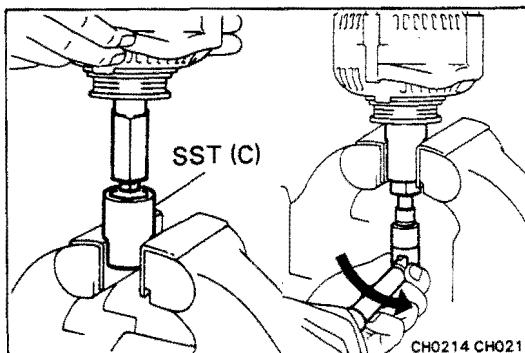

- (c) As shown in the illustration, mount SST (C) in a vise, and install the alternator to SST (C).

- (d) To loosen the pulley nut turn SST (A) in the direction shown in the figure.

**NOTICE: To prevent damage to the rotor shaft, do not loosen the pulley nut more than one-half of a turn.**

- (e) Remove the alternator from SST (C).

- (f) Turn SST (B) and remove SST (A and B).

- (g) Remove the pulley nut and pulley.



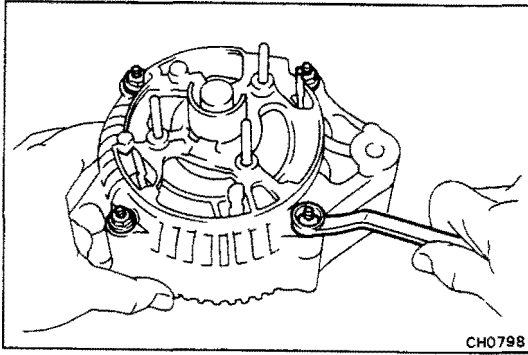

**6. REMOVE RECTIFIER END FRAME**

(a) Remove the four nuts.

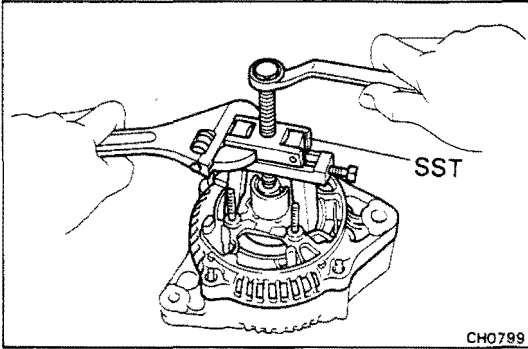

(b) Using SST, remove the rectifier end frame.  
SST 09286-46011

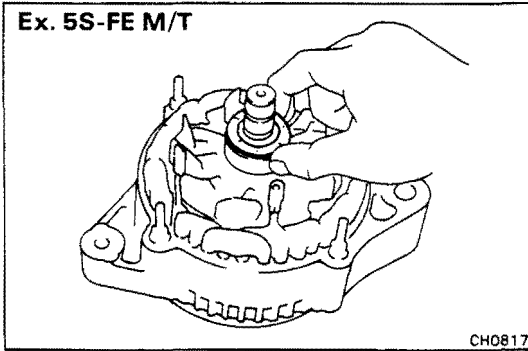

(c) (Ex. 5S-FE M/T)  
Remove the alternator washer.

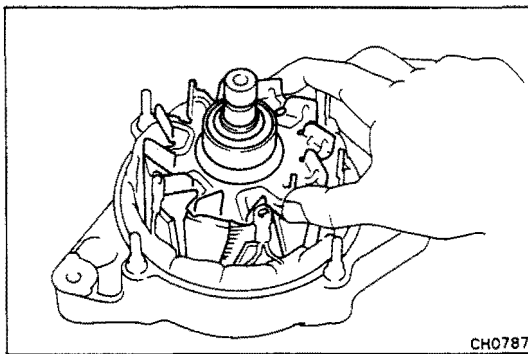

**7. REMOVE ROTOR FROM DRIVE END FRAME**

## INSPECTION AND REPAIR OF ALTERNATOR

### Rotor

#### 1. INSPECT ROTOR FOR OPEN CIRCUIT

Using an ohmmeter, check that there is continuity between the slip rings.

**Standard resistance (Cold): 2.8 – 3.0  $\Omega$**

If there is no continuity, replace the rotor.

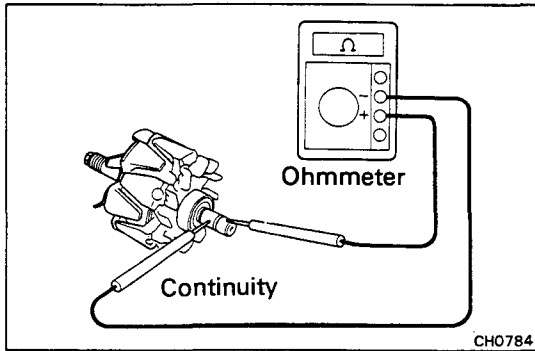

#### 2. INSPECT ROTOR FOR GROUND

Using an ohmmeter, check that there is no continuity between the slip ring and rotor.

If there is continuity, replace the rotor.

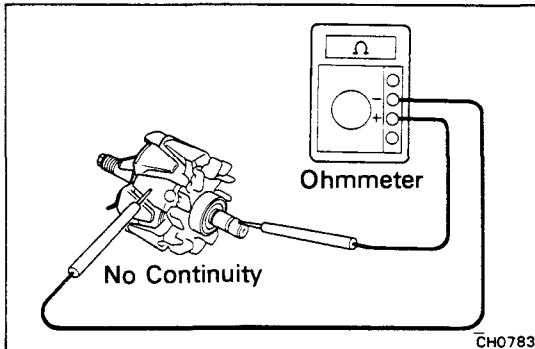

#### 3. INSPECT SLIP RINGS

(a) Check that the slip rings are not rough or scored.

If rough or scored, replace the rotor.

(b) Using vernier calipers, measure the slip ring diameter.

**Standard diameter: 14.2 – 14.4 mm  
(0.559 – 0.567 in.)**

**Minimum diameter: 12.8 mm (0.504 in.)**

If the diameter is less than minimum, replace the rotor.

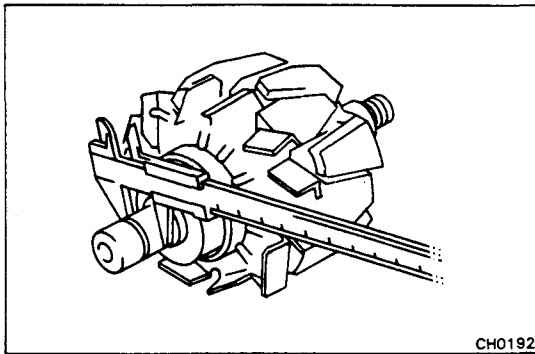

### Stator (Drive End Frame)

#### 1. INSPECT STATOR FOR OPEN CIRCUIT

Using an ohmmeter, check that there is continuity between the coil leads.

If there is no continuity, replace the drive end frame assembly.

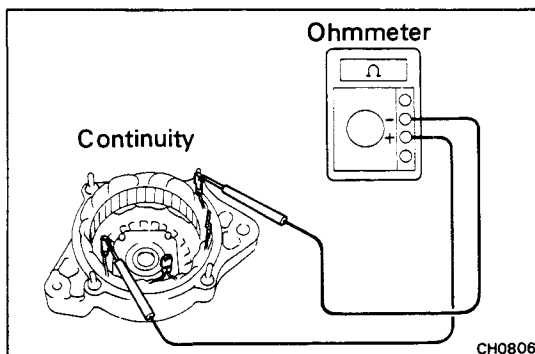

#### 2. INSPECT STATOR FOR GROUND

Using an ohmmeter, check that there is no continuity between the coil lead and drive end frame.

If there is continuity, replace the drive end frame assembly.

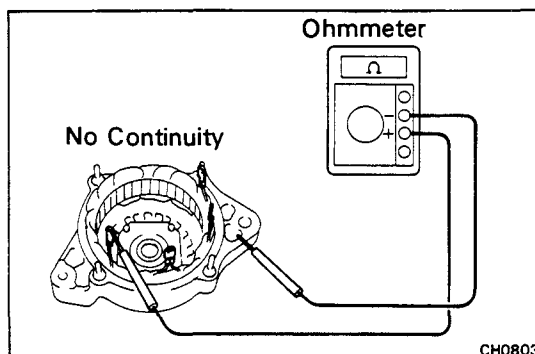

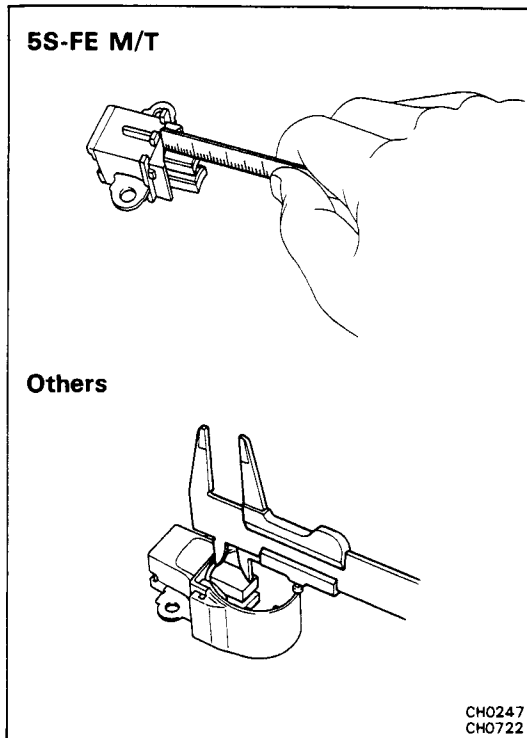

## Brushes

### 1. INSPECT EXPOSED BRUSH LENGTH

Using a vernier or scale, measure the exposed brush length.

**Standard exposed length: 10.5 mm (0.413 in.)**

**Minimum exposed length: 1.5 mm (0.059 in.)**

If the exposed length is less than minimum, replace the brushes (5S-FE M/T) or brushes and brush holder assembly (Others).

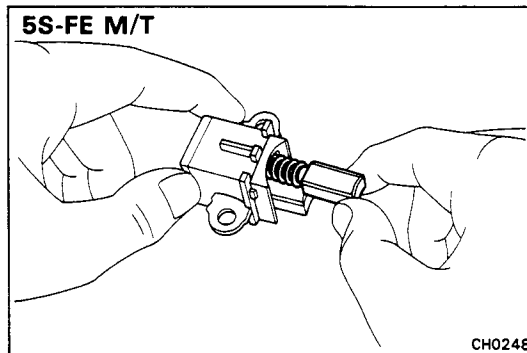

### 2. (5S-FE M/T) IF NECESSARY, REPLACE BRUSHES

- (a) Unsolder and remove the brush and spring.
- (b) Run the wire of a new brush through the hole in the brush holder, and insert the spring and brush into the brush holder.

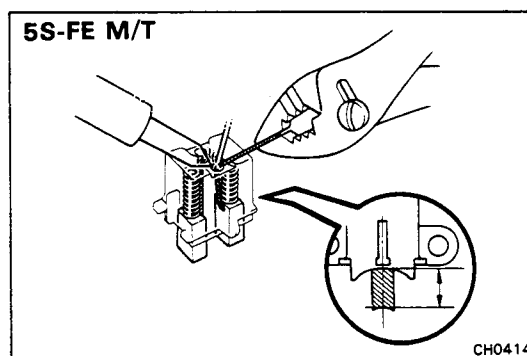

- (c) Solder the brush wire to the brush holder at specified exposed length.

**Exposed length: 10.5 mm (0.413 in.)**

- (d) Check that the brush moves smoothly in the brush holder.
- (e) Cut off the excess wire.
- (f) Apply insulation paint to the soldered point.

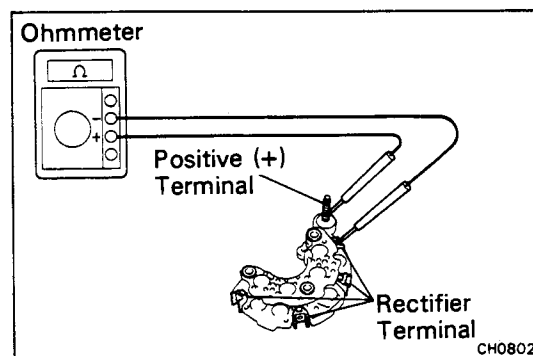

## Rectifiers (Rectifier Holder)

### 1. INSPECT POSITIVE RECTIFIER

- (a) Using an ohmmeter, connect one tester probe to the positive (+) terminal and the other to each rectifier terminal.
- (b) Reverse the polarity of the tester and repeat step (a).
- (c) Check that one shows continuity and the other shows no continuity.

If continuity is not as specified, replace the rectifier holder.

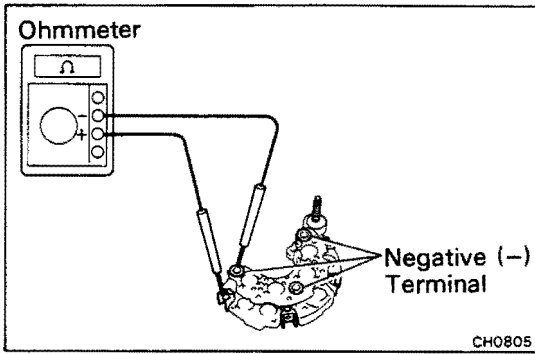

## 2. INSPECT NEGATIVE RECTIFIER

- (a) Using an ohmmeter, connect one tester probe to each negative (-) terminal and the other to each rectifier terminal.
- (b) Reverse the polarity of the tester probes and repeat step (a).
- (c) Check that one shows continuity and the other shows no continuity.

If continuity is not as specified, replace the rectifier holder.

## Bearings

### 1. INSPECT FRONT BEARING

Check that the bearing is not rough or worn.

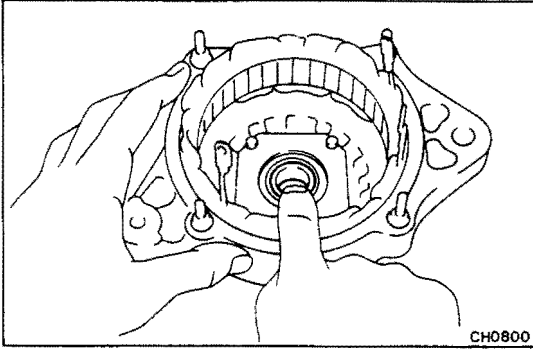

### 2. IF NECESSARY, REPLACE FRONT BEARING

- (a) Remove the four screws, bearing retainer and bearing.

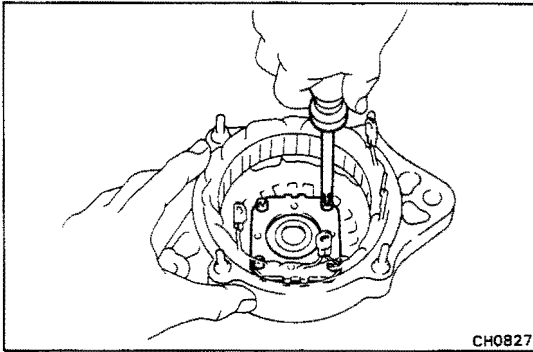

- (b) Using socket wrench and press, press out the bearing.

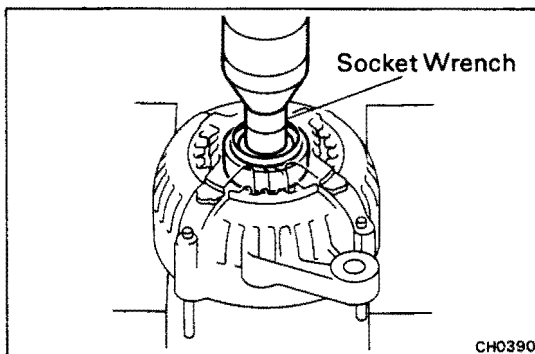

- (c) Using SST and a press, press in a new bearing SST 09608-20012 (09608-00030)

- (d) Install the bearing retainer with the four screws.

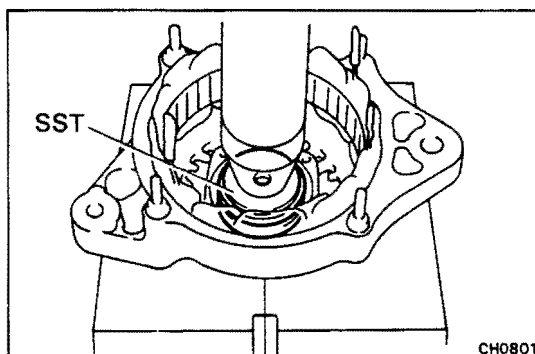

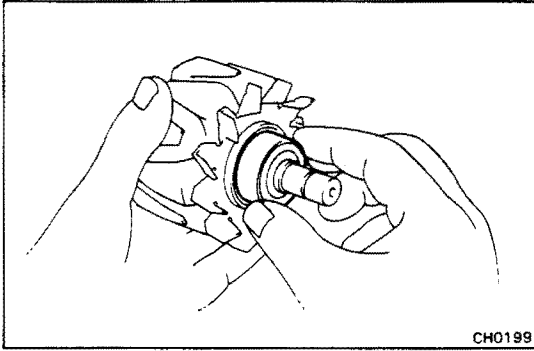

### 3. INSPECT REAR BEARING

Check that the bearing is not rough or worn.

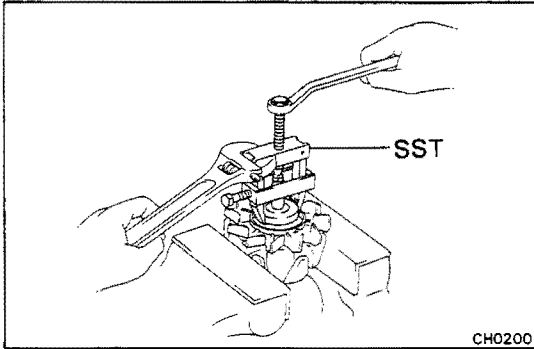

### 4. IF NECESSARY, REPLACE REAR BEARING

(a) Using SST, remove the bearing cover and bearing.  
SST 09820-00021

**NOTICE:** Be careful not to damage the fan.

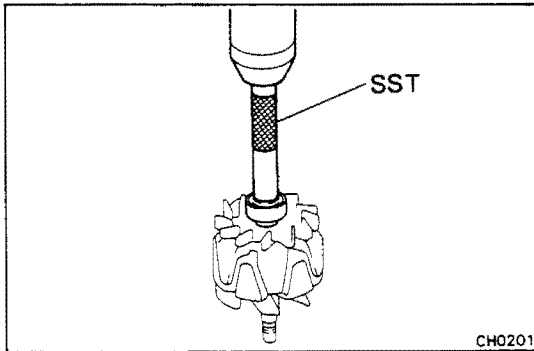

(b) Using SST and a press, press in a new bearing and bearing cover.

SST 09285-76010

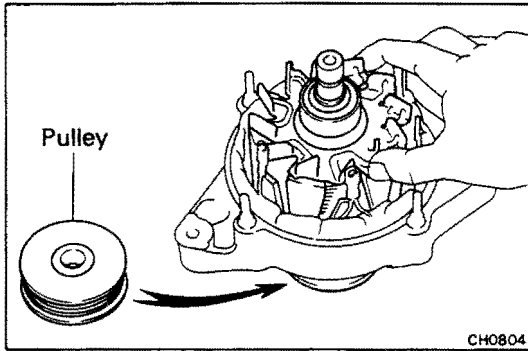

## ASSEMBLY OF ALTERNATOR

(See page CH-6)

### 1. INSTALL ROTOR TO RECTIFIER END FRAME

- (a) Place the rectifier end frame on the pulley.
- (b) Install the rotor to the rectifier end frame.

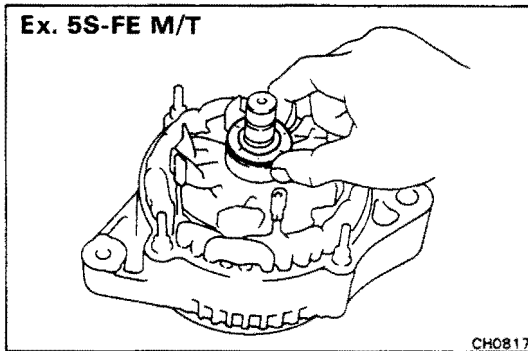

### 2. INSTALL RECTIFIER END FRAME

- (a) (Ex. 5S-FE M/T)  
Place the alternator washer on the rotor.

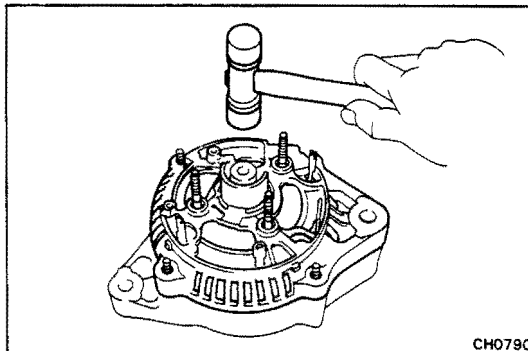

- (b) Using a plastic faced hammer, lightly tap in the rectifier end frame.

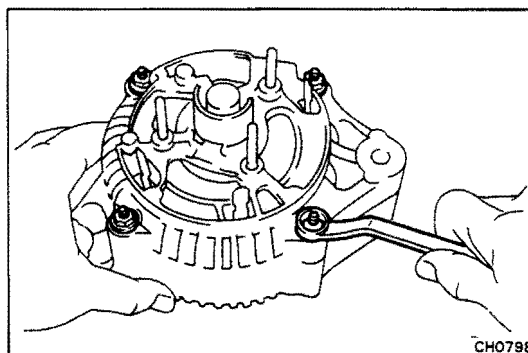

- (c) Install the four nuts.

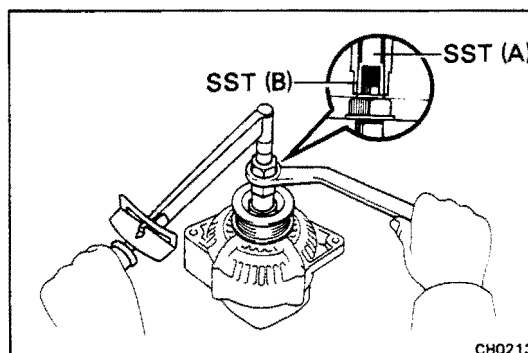

### 3. INSTALL PULLEY

- (a) Install the pulley to the rotor shaft by tightening the pulley nut by hand.
- (b) Hold SST (A) with a torque wrench, and tighten SST (B) clockwise to the specified torque.

SST 09820-63010

**Torque: 400 kg-cm (29 ft-lb, 39 N·m)**

- (c) Check that SST (A) is secured to the pulley shaft.

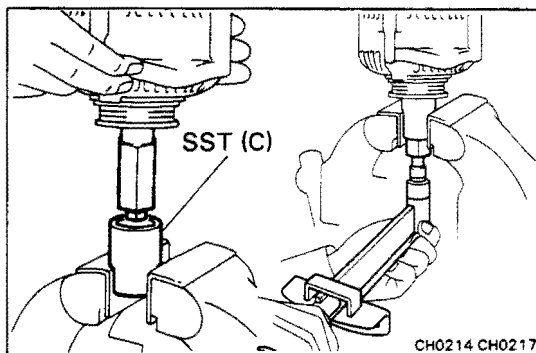

- (d) As shown in the illustration, mount SST (C) in a vise, and install the alternator to SST (C).
- (e) To torque the pulley nut turn SST (A) in the direction shown in the figure.

**Torque: 1,125 kg-cm (81 ft-lb, 110 N·m)**

- (f) Remove the alternator from SST (C).
- (g) Turn SST (B) and remove SST (A and B).

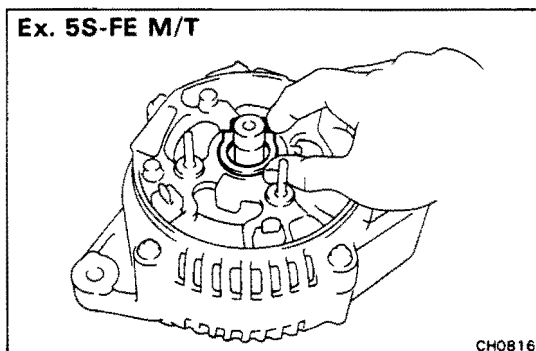

#### 4. INSTALL RECTIFIER HOLDER

- (a) (Ex. 5S-FE M/T)  
Place the seal plate on the rectifier end frame.

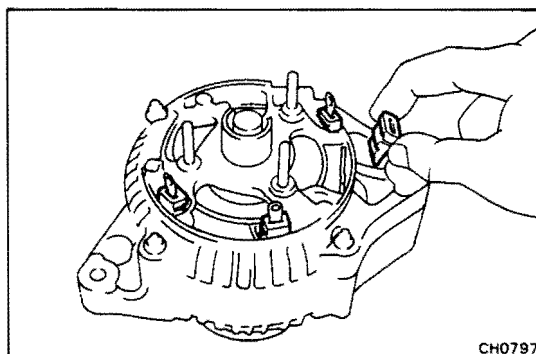

- (b) Install the four rubber insulators on the lead wires.

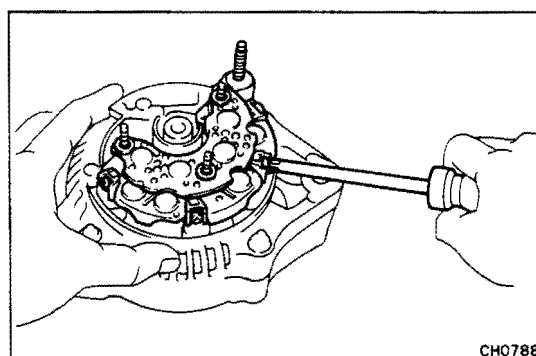

- (c) Install the rectifier holder with the four screws.

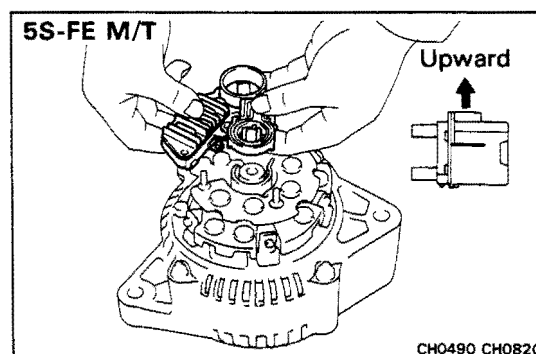

#### 5. INSTALL IC REGULATOR AND BRUSH HOLDER (5S-FE M/T)

- (a) Install the brush holder cover to the brush holder.  
**NOTICE: Be careful about the holder installation direction.**
- (b) Place the IC regulator together with the brush holder horizontally on the rectifier end frame.

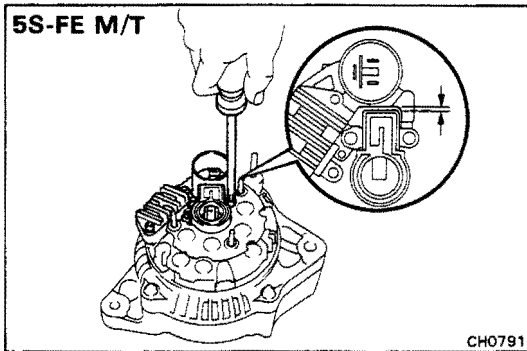

- (c) Install the five screws until there is a clearance of approx. 1 mm (0.04 in.) between the brush holder and connector.

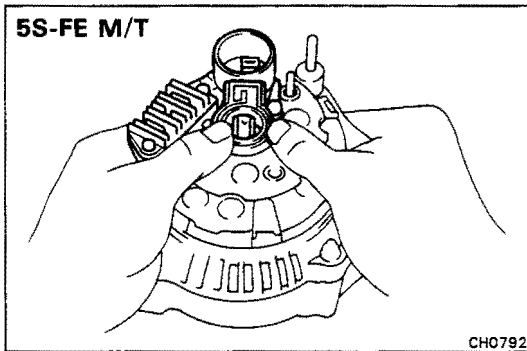

- (d) Fit the brush holder cover.

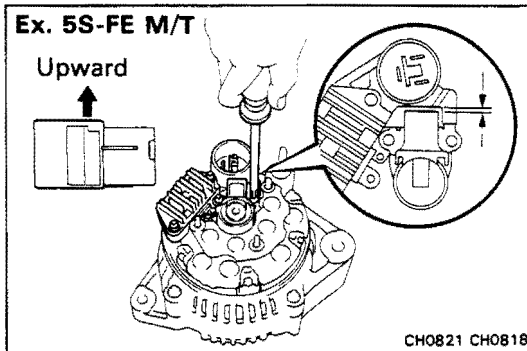

**(Ex. 5S-FE M/T)**

- (a) Place on the IC regulator and brush holder on the rectifier end frame.

**NOTICE:** Be careful about the holder installation direction.

- (b) Install the five screws until there is a clearance of approx. 1 mm (0.04 in.) between the brush holder and connector.

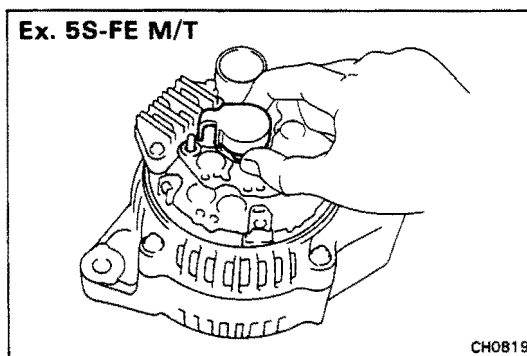

- (c) Place the brush holder cover on the brush holder.

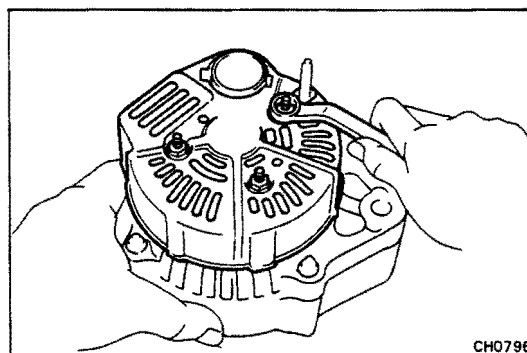

**6. INSTALL REAR END COVER**

- (a) Install the end cover with the three nuts.



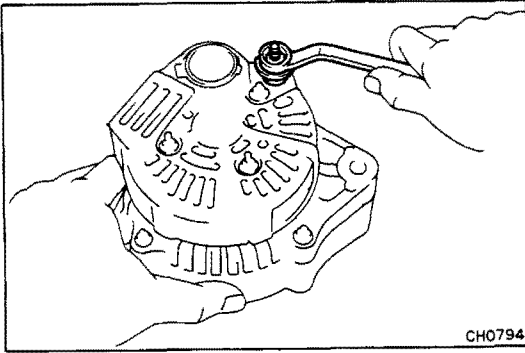

- (b) Install the terminal insulator with the nut.

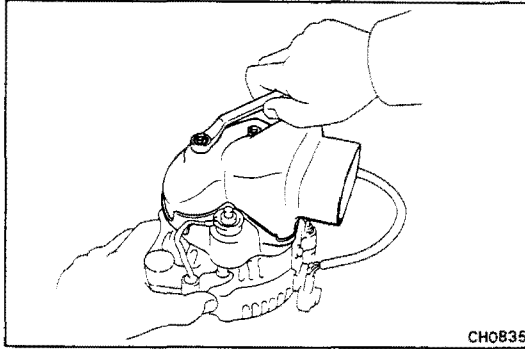

**7. (3S-GTE)  
INSTALL AIR DUCT**

- (a) Install the two bushings to the rectifier end frame.  
(b) Install the air duct with the bolt and two nuts.

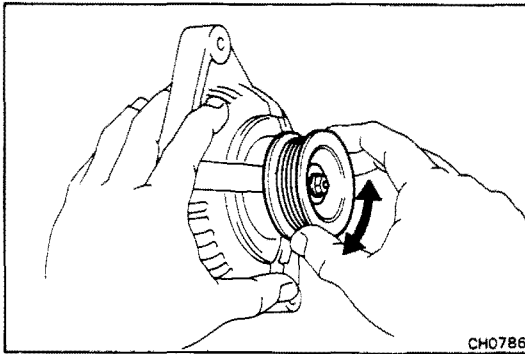

**8. CHECK THAT ROTOR ROTATES SMOOTHLY**

---

# SERVICE SPECIFICATIONS

	Page
ENGINE MECHANICAL (5S-FE) .....	A-2
ENGINE MECHANICAL (3S-GE and 3S-GTE) .....	A-6
TURBOCHARGER SYSTEM .....	A-11
EFI SYSTEM (5S-FE) .....	A-12
EFI SYSTEM (3S-FE) .....	A-15
EFI SYSTEM (3S-GTE) .....	A-18
COOLING SYSTEM .....	A-21
LUBRICATION SYSTEM .....	A-21
IGNITION SYSTEM .....	A-22
STARTING SYSTEM .....	A-22
CHARGING SYSTEM .....	A-22

**ENGINE MECHANICAL (5S-FE)****Specifications**

Engine tune-up	Drive belt				
	Deflection (Alternator)				
	w/ A/C	New belt	6 – 9 mm	0.24 – 0.35 in.	
		Used belt	9 – 11 mm	0.35 – 0.43 in.	
	w/o A/C	New belt	11 – 15 mm	0.43 – 0.59 in.	
		Used belt	13 – 17 mm	0.51 – 0.67 in.	
	Tension (Alternator) (Reference)				
	w/ A/C	New belt	70 – 80 kg		
		Used belt	45 – 55 kg		
	w/o A/C	New belt	45 – 55 kg		
		Used belt	20 – 35 kg		
	Engine coolant capacity (w/ Heater)				
		M/T	6.5 liters	6.8 US qts	5.7 Imp. qts
		A/T	6.6 liters	7.0 US qts	5.8 Imp. qts
	Engine oil capacity				
	w/ Oil cooler				
	Drain and refill	w/ Oil filter change	4.2 liters	4.4 US qts	3.7 Imp. qts
		w/o Oil filter change	3.8 liters	4.0 US qts	3.3 Imp. qts
	Dry fill		4.6 liters 4.9 US qts 4.0 Imp. qts		
	w/o Oil cooler				
Drain and refill	w/ Oil filter change	4.1 liters	4.3 US qts	3.6 Imp. qts	
	w/o Oil filter change	3.7 liters	3.9 US qts	3.3 Imp. qts	
Dry fill		4.5 liters 4.8 US qts 4.0 Imp. qts			
Engine oil API grade					
Europe	3S-GE and Australia	SE, SF, SG or better			
Europe	3S-GTE	SF, SG or better			
Others		SD, SE, SF, SG or better			
Battery specific gravity		1.25 – 1.27 (when fully charged at 20°C (68°F))			
High-tension cord resistance	Limit	25 kΩ per cord			
Spark plug					
Type	ND	K16R-U11			
	NGK	BKR5EYA11			
Air gap		1.1 mm	0.043 in.		
Valve clearance	Intake	0.19 – 0.29 mm	0.007 – 0.011 in.		
	Exhaust	0.28 – 0.38 mm	0.011 – 0.015 in.		
Ignition timing		10° BTDC @ idle (w/ Terminals TE1 and E1 connected)			
Firing order		1 – 3 – 4 – 2			
Idle speed		700 ± 50 rpm			
Idle CO concentration		0 – 0.5 %			
Intake manifold vacuum	at Idle speed	450 mmHg (17.7 in.Hg, 60 kPa)			

## Specifications (Cont'd)

Compression pressure	at 250 rpm	STD		12.5 kg/cm <sup>2</sup> (178 psi, 1,226 kPa) or more		
		Limit		10.0 kg/cm <sup>2</sup> 142 psi 981 kPa		
	Difference of pressure between each cylinder			1.0 kg/cm <sup>2</sup> (14 psi, 98 kPa) or less		
Idler pulley tension spring	Free length			46.1 mm	1.815 in.	
	Installed load		at 51.9 mm (2.043 in.)	6.0 – 7.0 kg (13.2 – 15.4 lb, 59 – 69 N)		
Cylinder head	Warpage	Cylinder block side	Limit	0.05 mm	0.020 in.	
		Manifold side	Limit	0.08 mm	0.031 in.	
	Valve seat	Refacing angle		30°, 45°, 75°		
		Contacting angle		45°		
		Contacting width		1.0 – 1.4 mm	0.039 – 0.055 in.	
Valve guide bushing	Inside diameter			6.010 – 6.030 mm 0.2366 – 0.2374 in.		
	Outside diameter (for repair part)	STD		11.048 – 11.059 mm	0.4350 – 0.4354 in.	
		O/S 0.05		11.098 – 11.109 mm	0.4369 – 0.4374 in.	
Valve	Valve overall length	STD	Intake	100.60 mm	3.9606 in.	
			Exhaust	100.45 mm	3.9547 in.	
		Limit	Intake	100.1 mm	3.941 in.	
			Exhaust	100.0 mm	3.937 in.	
		Valve face angle		44.5°		
	Stem diameter		Intake	5.970 – 5.985 mm	0.2350 – 0.2356 in.	
			Exhaust	5.965 – 5.980 mm	0.2356 – 0.2354 in.	
	Stem oil clearance	STD	Intake	0.025 – 0.060 mm	0.0010 – 0.0024 in.	
			Exhaust	0.030 – 0.065 mm	0.0012 – 0.0026 in.	
		Limit	Intake	0.08 mm	0.0031 in.	
			Exhaust	0.10 mm	0.0039 in.	
	Margin thickness	STD		0.8 – 1.2 mm	0.031 – 0.047 in.	
Limit			0.5 mm	0.020 in.		
Valve spring	Squareness		Limit	2.0 mm	0.079 in.	
	Free length			45.0 mm	1.772 in.	
	Installed tension		at 34.7 mm (1.366 in.)	16.7 – 19.3 kg (36.8 – 42.5 lb, 164 – 189 N)		
Valve lifter	Lifter diameter			27.975 – 27.985 mm	1.1014 – 1.1018 in.	
	Lifter bore diameter			28.000 – 28.021 in.	1.1024 – 1.1032 in.	
	Oil clearance		STD	0.015 – 0.046 mm	0.0006 – 0.0018 in.	
		Limit		0.07 mm	0.0028 in.	
Manifold	Warpage		Limit	0.3 mm	0.0118 in.	
Camshaft	Thrust clearance	STD	Intake	0.045 – 0.100 in.	0.0018 – 0.0039 in.	
			Exhaust	0.030 – 0.085 in.	0.0012 – 0.0033 in.	
		Limit	Intake	0.12 mm	0.0047 in.	
			Exhaust	0.10 mm	0.0039 in.	
	Journal oil clearance	STD		0.025 – 0.062 mm	0.0010 – 0.0024 in.	
		Limit		0.10 mm	0.0039 in.	
	Journal diameter			26.959 – 26.975 mm	1.0614 – 1.0620 in.	
	Circle runout		Limit	0.04 mm	0.0016 in.	
	Cam lobe height	STD	Intake	35.310 – 35.410 mm	1.3902 – 1.3941 in.	
			Exhaust	35.560 – 35.660 mm	1.4000 – 1.4039 in.	
		Limit	Intake	35.20 mm	1.3858 in.	
			Exhaust	35.45 mm	1.3957 in.	
Camshaft gear backlash	STD		0.020 – 0.200 mm	0.008 – 0.0079 in.		
	Limit		0.30 mm	0.0188 in.		
Camshaft gear spring end free distance			22.5 – 22.9 mm	0.886 – 0.902 in.		

## Specifications (Cont'd)

Cylinder block	Cylinder head surface warpage	Limit	0.05 mm	0.0020 in.	
	Cylinder bore diameter	STD	87.000 – 87.010 mm	3.4252 – 3.4256 in.	
		Mark 1	87.010 – 87.020 mm	3.4256 – 3.4260 in.	
		Mark 2	87.020 – 87.030 mm	3.4260 – 3.4264 in.	
	Mark 3	87.020 – 87.030 mm	3.4260 – 3.4264 in.		
		Limit	87.23 mm	3.4342 in.	
Piston and piston ring	Piston diameter	Mark 1	86.911 – 86.921 mm	3.4217 – 3.4221 in.	
		Mark 2	86.921 – 86.931 mm	3.4221 – 3.4225 in.	
		Mark 3	86.931 – 86.941 mm	3.4225 – 3.4229 in.	
	Piston oil clearance	STD	0.079 – 0.099 mm	0.0031 – 0.0039 in.	
		Limit	0.119 mm	0.0047 in.	
	Piston ring groove clearance		0.030 – 0.070 mm	0.0012 – 0.0028 in.	
	Piston ring end gap	STD	No.1	0.270 – 0.500 mm	0.0106 – 0.0197 in.
			No.2	0.350 – 0.600 mm	0.0138 – 0.0234 in.
			Oil	0.200 – 0.550 mm	0.0079 – 0.0217 in.
		Limit	No.1	1.10 mm	0.0433 in.
			No.2	1.20 mm	0.0472 in.
	Oil	1.15 mm	0.0453 in.		
Connecting rod	Thrust clearance	STD	0.160 – 0.312 mm	0.0063 – 0.0123 in.	
		Limit	0.35 mm	0.35 in.	
	Connecting rod bearing center wall thickness	STD	Mark 1	1.484 – 1.488 mm	0.0584 – 0.0586 in.
			Mark 2	1.488 – 1.492 mm	0.0586 – 0.0587 in.
			Mark 3	1.492 – 1.496 mm	0.0587 – 0.0589 in.
	Connecting rod oil clearance	STD	STD	0.024 – 0.055 mm	0.0009 – 0.0022 in.
			U/S 0.25	0.023 – 0.069 mm	0.0009 – 0.0027 in.
		Limit		0.08 mm	0.0031 in.
	Rod bending Limit per 100 mm (3.94 in.)			0.05 mm	0.0020 in.
	Rod twist Limit per 100 mm (3.94 in.)			0.15 mm	0.0059 in.
	Bushing inside diameter			22.005 – 22.017 mm	0.8663 – 0.8668 in.
	Piston pin diameter			21.997 – 22.009 mm	0.8660 – 0.8665 in.
	Piston pin oil clearance	STD		0.005 – 0.011 mm	0.0002 – 0.0004 in.
Limit			0.05 mm	0.0020 in.	
Connecting rod bolt outside diameter	STD		7.860 – 8.000 mm	0.3094 – 0.3150 in.	
	Limit		7.60 mm		
Crankshaft	Thrust clearance	STD	0.020 – 0.220 mm	0.0008 – 0.0087 in.	
		Limit	0.30 mm	0.0118 in.	
	Thrust washer thickness	STD	2.440 – 2.490 mm	0.0961 – 0.0980 in.	
	Main journal oil clearance	STD	No.3	0.025 – 0.044 mm	0.0010 – 0.0017 in.
			U/S 0.25	0.027 – 0.067 mm	0.0011 – 0.0026 in.
			Others	0.015 – 0.034 mm	0.0006 – 0.0013 in.
		Limit	U/S 0.25	0.019 – 0.059 mm	0.0007 – 0.0023 in.
					0.08 mm
Main journal diameter	STD		54.988 – 55.003 mm	2.1653 – 2.1655 in.	
	U/S 0.25		54.745 – 54.755 mm	2.1553 – 2.1557 in.	

## Specifications (Cont'd)

Crankshaft (cont'd)	Main bearing center wall thickness					
		STD	No.3	Mark 1	1.992 – 1.995 mm	0.0784 – 0.0785 in.
				Mark 2	1.995 – 1.998 mm	0.0785 – 0.0787 in.
				Mark 3	1.998 – 2.001 mm	0.0787 – 0.0788 in.
				Mark 4	2.001 – 2.004 mm	0.0788 – 0.0789 in.
				Mark 5	2.004 – 2.007 mm	0.0789 – 0.0790 in.
		STD	Others	Mark 1	1.997 – 2.000 mm	0.0786 – 0.0787 in.
				Mark 2	2.000 – 2.003 mm	0.0787 – 0.0789 in.
				Mark 3	2.003 – 2.006 mm	0.0789 – 0.0790 in.
				Mark 4	2.006 – 2.009 mm	0.0790 – 0.0791 in.
				Mark 5	2.009 – 2.012 mm	0.0791 – 0.0792 in.
		Crank pin diameter		STD	51.985 – 52.000 mm	2.0466 – 2.0472 in.
				U/S 0.25	51.745 – 51.755 mm	2.0372 – 2.0376 in.
		Circle runout		Limit	0.06 mm	0.0024 in.
		Main journal taper and out-of-round		Limit	0.02 mm	0.0008 in.
		Crank pin taper and out-of-round		Limit	0.02 mm	0.0008 in.

## Torque Specifications

Part tightened	kg-cm	ft-lb	N-m
Oil pump pulley x Oil pump drive shaft	290	21	28
No.2 idler pulley x Cylinder block	425	31	42
Crankshaft pulley x Crankshaft	1,100	80	108
Camshaft timing pulley x Camshaft	550	40	57
	For SST		
	380	27	37
No.1 idler pulley x Cylinder head	425	31	42
RH engine mounting bracket x Cylinder block	530	38	52
Cylinder head x Cylinder block	1st	500	47
	2nd	Turn 90°	
Spark plug tube x Cylinder head	400	29	39
Camshaft bearing cap x Cylinder head	190	14	19
Cylinder head cover x Cylinder head	180	13	18
Alternator bracket cylinder head	425	31	42
Engine hanger x Cylinder head	250	18	25
No.3 timing belt cover x Cylinder head	80	69 in.-lb	7.8
Intake manifold x Cylinder head	195	14	19
Intake manifold stay x Intake manifold	195	14	19
Intake manifold stay x Cylinder block	425	31	42
EGR valve x Intake manifold	130	9	13
EGR pipe x Cylinder head	600	43	59
Water by-pass pipe x Water pump cover	95	82 in.-lb	9.3
Water outlet x Cylinder head	150	11	15
Catalytic converter x Exhaust manifold	300	22	29
Exhaust manifold x Cylinder head	500	36	49
Exhaust manifold stay x Catalytic converter	425	31	42
Exhaust manifold stay x Cylinder block	425	31	42
Main bearing cap x Cylinder block	600	43	59
Connecting rod cap x Connecting rod	1st	250	25
	2nd	Turn 90°	
Rear oil seal retainer x Cylinder block	95	82 in.-lb	9.3
PS pump bracket x Cylinder block	440	32	43
Rear end plate x Cylinder block	95	82 in.-lb	9.3
Flywheel x Crankshaft (M/T)	900	65	88
Drive plate x Crankshaft (A/T)	850	61	83

**ENGINE MECHANICAL (3S-GE and 3S-GTE)****Specifications**

Engine tune-up	Drive belt				
	Deflection (Alternator)				
	w/ A/C	New belt	9 – 11 mm	0.35 – 0.43 in.	
		Used belt	13 – 16 mm	0.51 – 0.63 in.	
	w/o A/C	New belt	11 – 14 mm	0.43 – 0.55 in.	
		Used belt	12 – 18 mm	0.47 – 0.71 in.	
	Tension (Alternator) (Reference)				
	w/ A/C	New belt	70 – 80 kg		
		Used belt	30 – 45 kg		
	w/o A/C	New belt	47 – 72 kg		
		Used belt	36 – 52 kg		
	Engine coolant capacity (w/ Heater)				
		M/T	6.0 liters	6.3 US qts	5.3 Imp. qts
		A/T	6.5 liters	6.9 US qts	5.7 Imp. qts
	Engine oil capacity				
	Drain and refill	w/ Oil filter change	3.9 liters	4.1 US qts	3.4 Imp. qts
		w/o Oil filter change	3.6 liters	3.8 US qts	3.2 Imp. qts
		Dry fill	4.3 liters	4.5 US qts	3.8 Imp. qts
	Engine oil API grade		SD, SE or better		
	Battery specific gravity		1.25 – 1.27 (when fully charged at 20°C (68°F))		
High-tension cord resistance	Limit	25 kΩ per cord			
Spark plug					
Conventional type					
Type	ND	K20R-U			
	NGK	BKR6EYA			
Air gap		0.8 mm	0.031 in.		
Platinum tipped type (Reference)					
Type	ND	PK20R8			
	NGK	BKR6EP8			
Air gap		0.8 mm	0.031 in.		
Valve clearance	Intake	0.15 – 0.25 mm	0.006 – 0.010 in.		
	Exhaust	0.20 – 0.30 mm	0.008 – 0.012 in.		
Ignition timing		10° BTDC @ idle (w/ Terminals TE1 and E1 connected)			
Firing order		1 – 3 – 4 – 2			
Idle speed		800 ± 50 rpm			
Idle CO concentration	w/ TWC	0 – 0.5%			
	w/o TWC	1.0 ± 0.5%			
Intake manifold vacuum	at Idle speed	450 mmHg (17.7 in.Hg, 60 kPa)			

## Specifications (Cont'd)

Compression pressure	at 250 rpm	STD	3S-GE	12.5 kg/cm <sup>2</sup> (178 psi, 1,226 kPa) or more	
			3S-GTE	11.5 kg/cm <sup>2</sup> (164 psi, 1,128 kPa) or more	
		Limit	3S-GE	10.0 kg/cm <sup>2</sup> 142 psi 981 kPa	
			3S-GTE	9.0 kg/cm <sup>2</sup> 128 psi 883 kPa	
	Difference of pressure between each cylinder			1.0 kg/cm <sup>2</sup> (14 psi, 98 kPa) or less	
Timing belt tensioner	Protrusion			8.5 – 9.5 mm	0.335 – 0.374 in.
Cylinder head	Warpage	Cylinder block side	Limit	0.20 mm	0.0079 in.
			Intake manifold side	Limit	0.20 mm
	Exhaust manifold side	Limit	0.30 mm	0.0118 in.	
		Valve seat Refacing angle		30°, 45°, 75°	
		Contacting angle		45°	
Contacting width		1.0 – 1.4 mm	0.039 – 0.055 in.		
Valve guide bushing	Inside diameter			6.000 – 6.018 mm	0.2362 – 0.2369 in.
	Outside diameter (for repair part)				
		STD		11.030 – 11.041 mm	0.4343 – 0.4347 in.
		O/S 0.05		11.080 – 11.091 mm	0.4362 – 0.4367 in.
Valve	Valve overall length	STD	Intake	105.50 mm	4.1535 in.
			Exhaust	99.55 mm	3.9193 in.
		Limit	Intake	104.80 mm	4.1260 in.
			Exhaust	98.85 mm	3.8917 in.
	Valve face angle			44.5°	
	Stem diameter		Intake	5.960 – 5.975 mm	0.2346 – 0.2352 in.
			Exhaust	5.955 – 5.970 mm	0.2344 – 0.2350 in.
	Stem oil clearance	STD	Intake	0.025 – 0.058 mm	0.0010 – 0.0023 in.
			Exhaust	0.030 – 0.063 mm	0.0012 – 0.0025 in.
		Limit	Intake	0.08 mm	0.0031 in.
			Exhaust	0.10 mm	0.0039 in.
Margin thickness	STD		0.8 – 1.2 mm	0.031 – 0.047 in.	
	Limit		0.5 mm	0.020 in.	
Valve spring	Squareness			Limit	2.0 mm 0.079 in.
	Free length				44.43 mm 1.7492 in.
	Installed tension at 34.4 mm (1.354 in.)				20.5 – 24.1 kg (45.2 – 53.1 lb, 201 – 236 N)
Valve lifter	Lifter diameter			27.975 – 27.985 mm	1.1014 – 1.1018 in.
	Lifter bore diameter			28.000 – 28.021 mm	1.1024 – 1.1032 in.
	Oil clearance	STD		0.015 – 0.046 mm	0.0006 – 0.0018 in.
		Limit		0.07 mm	0.0028 in.
Manifold	Warpage			Limit	0.20 mm 0.0079 in.



## Specifications (Cont'd)

Camshaft	Thrust clearance	STD		0.120 – 0.240 in.	0.0047 – 0.0094 in.		
		Limit		0.30 mm	0.0118 in.		
	Journal oil clearance	STD		0.025 – 0.062 mm	0.0010 – 0.0024 in.		
		Limit		0.08 mm	0.0031 in.		
	Journal diameter			26.959 – 26.975 mm	1.0614 – 1.0620 in.		
	Circle runout	Limit		0.06 mm	0.0024 in.		
	Cam lobe height	STD	3S-GE		41.310 – 41.410 mm	1.6264 – 1.6303 in.	
3S-GTE				41.010 – 41.110 mm	1.6146 – 1.6185 in.		
Limit		3S-GE		41.20 mm	1.6220 in.		
		3S-GTE		39.90 mm	1.5709 in.		
Air intake chamber (3S-GE)	Warpage	Limit		0.20 mm	0.0079 in.		
ACIS valve (3S-GE)	Warpage	Limit		0.20 mm	0.0079 in.		
T-VIS valve (3S-GTE)	Warpage	Limit		0.20 mm	0.0079 in.		
Cylinder block	Cylinder head surface warpage	Limit		0.05 mm	0.0020 in.		
	Cylinder bore diameter	STD	Mark 1		86.000 – 86.010 mm	3.3858 – 3.3862 in.	
			Mark 2		86.010 – 86.020 mm	3.3862 – 3.3866 in.	
			Mark 3		86.020 – 86.030 mm	3.3866 – 3.3870 in.	
Limit			86.23 mm	3.3949 in.			
Piston and piston ring	Piston diameter	3S-GE	Mark 1		85.960 – 85.970 mm	3.3842 – 3.3846 in.	
			Mark 2		85.970 – 85.980 mm	3.3846 – 3.3850 in.	
			Mark 3		85.980 – 85.990 mm	3.3850 – 3.3854 in.	
		3S-GTE	Mark 1		85.920 – 85.930 mm	3.3827 – 3.3831 in.	
			Mark 2		85.930 – 85.940 mm	3.3831 – 3.3835 in.	
			Mark 3		85.940 – 85.950 mm	3.3835 – 3.3839 in.	
	Piston oil clearance	STD	3S-GE		0.030 – 0.050 mm	0.0012 – 0.0020 in.	
			3S-GTE		0.070 – 0.090 mm	0.0028 – 0.0035 in.	
		Limit	3S-GE		0.070 mm	0.0028 in.	
			3S-GTE		0.110 mm	0.0043 in.	
	Piston ring groove clearance		No.1		0.040 – 0.080 mm	0.0016 – 0.0031 in.	
			No.2		0.030 – 0.070 mm	0.0012 – 0.0028 in.	
	Piston ring end gap	STD	w/ TWC	No.1		0.330 – 0.550 mm	0.0130 – 0.0217 in.
				No.2		0.450 – 0.670 mm	0.0177 – 0.0264 in.
			Oil	No.1		0.200 – 0.600 mm	0.0079 – 0.0236 in.
				No.2		0.200 – 0.420 mm	0.0079 – 0.0165 in.
				Oil		0.300 – 1.000 mm	0.0118 – 0.0394 in.
		Limit	w/ TWC	No.1		0.85 mm	0.0335 in.
				No.2		0.97 mm	0.0382 in.
			Oil	No.1		0.90 mm	0.0354 in.
w/o TWC				No.1		0.85 mm	0.0335 in.
				No.2		0.72 mm	0.0283 in.
	Oil		1.30 mm	0.0512 in.			

## Specifications (Cont'd)

Connecting rod	Thrust clearance	STD	0.160 – 0.312 mm	0.0063 – 0.0123 in.		
		Limit	0.35 mm	0.35 in.		
	Connecting rod bearing center wall thickness					
		STD	Mark 1	1.484 – 1.488 mm	0.0584 – 0.0586 in.	
			Mark 2	1.488 – 1.492 mm	0.0586 – 0.0587 in.	
			Mark 3	1.492 – 1.496 mm	0.0587 – 0.0589 in.	
	Connecting rod oil clearance					
		STD	STD	0.024 – 0.055 mm	0.0009 – 0.0022 in.	
			U/S	0.023 – 0.069 mm	0.0009 – 0.0027 in.	
		Limit		0.08 mm	0.0031 in.	
	Rod bending Limit per 100 mm (3.94 in.)			0.05 mm	0.0020 in.	
	Rod twist Limit per 100 mm (3.94 in.)			0.15 mm	0.0059 in.	
Bushing inside diameter			22.005 – 22.017 mm	0.8663 – 0.8668 in.		
Piston pin diameter			21.997 – 22.009 mm	0.8660 – 0.8665 in.		
Piston pin oil clearance	STD		0.005 – 0.011 mm	0.0002 – 0.0004 in.		
	Limit		0.05 mm	0.0020 in.		
Crankshaft	Thrust clearance	STD	0.020 – 0.220 mm	0.0008 – 0.0087 in.		
		Limit	0.30 mm	0.0118 in.		
	Thrust washer thickness	STD	2.440 – 2.490 mm	0.0961 – 0.0980 in.		
	Main journal oil clearance					
		STD	No.3	STD	0.025 – 0.044 mm	0.0010 – 0.0017 in.
				U/S 0.25	0.021 – 0.061 mm	0.0008 – 0.0024 in.
			Others		0.015 – 0.034 mm	0.0006 – 0.0013 in.
				U/S 0.25	0.029 – 0.069 mm	0.0011 – 0.0027 in.
		Limit			0.08 mm	0.0031 in.
	Main journal diameter	STD		54.988 – 55.003 mm	2.1653 – 2.1655 in.	
				U/S	54.745 – 54.755 mm	2.1553 – 2.1557 in.
	Main bearing center wall thickness					
		STD	No.3	Mark 1	1.992 – 1.995 mm	0.0784 – 0.0785 in.
				Mark 2	1.995 – 1.998 mm	0.0785 – 0.0787 in.
				Mark 3	1.998 – 2.001 mm	0.0787 – 0.0788 in.
				Mark 4	2.001 – 2.004 mm	0.0788 – 0.0789 in.
				Mark 5	2.004 – 2.007 mm	0.0789 – 0.0790 in.
		STD	Others	Mark 1	1.997 – 2.000 mm	0.0786 – 0.0787 in.
				Mark 2	2.000 – 2.003 mm	0.0787 – 0.0789 in.
				Mark 3	2.003 – 2.006 mm	0.0789 – 0.0790 in.
				Mark 4	2.006 – 2.009 mm	0.0790 – 0.0791 in.
				Mark 5	2.009 – 2.012 mm	0.0791 – 0.0792 in.
	Crank pin diameter	STD		47.985 – 48.000 mm	1.8892 – 1.8898 in.	
			U/S	47.745 – 47.755 mm	1.8797 – 1.8801 in.	
Circle runout	Limit		0.06 mm	0.0024 in.		
Main journal taper and out-of-round						
	Limit		0.02 mm	0.0008 in.		
Crank pin taper and out-of-round						
	Limit		0.02 mm	0.0008 in.		

## Torque Specifications

Part tightened	kg-cm	ft-lb	N·m
Oil pump pulley x Oil pump drive shaft	355	26	35
No.2 idler pulley x Cylinder block	440	32	43
No.1 idler pulley bracket x Cylinder head	440	32	43
Crankshaft pulley x Crankshaft	1,100	80	108
Camshaft timing pulley x Camshaft	600	43	59
Timing belt tensioner x Cylinder head	420	30	41
	For SST		
RH engine mounting bracket x Cylinder block	210	15	21
Cylinder head x Cylinder block	530	38	52
	1st	500	36
	2nd	Turn 90°	49
Camshaft bearing cap x Cylinder head	190	14	19
No.3 timing belt cover x Cylinder head	25	21 in.-lb	2.5
Cylinder head cover x Cylinder head	180	13	18
RH rear engine hanger x Cylinder head	195	14	19
Intake manifold x Cylinder head	195	14	19
Intake manifold stay x Intake manifold	3S-GE	400	29
	3S-GTE	260	19
Intake manifold stay x Cylinder block	3S-GE	400	29
	3S-GTE	260	19
ACIS valve x Intake manifold (3S-GE)	195	14	19
Air intake chamber x Intake manifold (3S-GE)	195	14	19
No.1 air intake chamber stay x Cylinder head (3S-GE)	195	14	19
No.1 air intake chamber stay x Air intake chamber (3S-GE)	400	29	39
No.2 air intake chamber stay x Cylinder head (3S-GE)	195	14	19
No.2 air intake chamber stay x Air intake chamber (3S-GE)	195	14	19
Water by-pass pipe x Water pump cover	80	69 in.-lb	7.8
Water outlet x Cylinder head	400	29	39
EGR valve x Intake manifold (3S-GTE)	195	14	19
EGR pipe x Cylinder head (3S-GTE)	195	14	19
LH engine hanger x Cylinder head	12 mm head bolt	130	9
	14 mm head bolt	195	14
Exhaust manifold x Cylinder head	3S-GE	440	32
	3S-GTE	530	38
Exhaust manifold stay x Cylinder block (3S-GE)	600	32	43
Exhaust manifold stay x Exhaust manifold (3S-GE)			
	Bolt	600	43
	Nut	440	32
Catalytic converter x Turbine outlet elbow (3S-GTE)	300	22	29
Catalytic converter stay x Catalytic converter (3S-GTE)	600	43	59
No.1 alternator bracket x Cylinder head	400	29	39
Alternator x No.1 alternator bracket	12 mm head bolt	195	14
	14 mm head bolt	530	38
No.2 alternator bracket x No.1 alternator bracket	400	29	39
No.2 alternator bracket x Turbine outlet elbow (3S-GTE)	440	32	43
No.2 alternator bracket x Cylinder block (3S-GE)	400	29	39
Main bearing cap x Cylinder block	600	43	59
Connecting rod cap x Connecting rod	680	49	67
Rear oil seal retainer x Cylinder block	95	82 in.-lb	9.3
Knock sensor x Cylinder head	450	33	44
PS pump bracket x Cylinder block	440	32	43
Rear end plate x Cylinder block	95	82 in.-lb	9.3
Flywheel x Crankshaft (M/T)	1,100	80	108
Drive plate x Crankshaft (A/T)	850	61	83

**TURBOCHARGER SYSTEM****Specifications**

Turbocharger	Turbocharging pressure	0.50 – 0.83 kg/cm <sup>2</sup> (7.1 – 11.8 psi, 49 – 81 kPa)
	Impeller wheel axial play	0.13 mm (0.0051 in.) or less
	Impeller wheel radial play	0.18 mm (0.0071 in.) or less

**Torque Specifications**

Part tightened	kg-cm	ft-lb	N·m
Turbine outlet elbow x Turbocharger	650	47	64
Side bearing housing plate x Turbocharger	120	9	11
Turbo water pipe x Turbocharger	120	9	11
Turbocharger x Exhaust manifold	650	47	64
Oil pipe x Turbocharger	175	13	17
Oil pipe x Cylinder block (Union bolt)	525	38	51
Turbocharger stay x Turbocharger	705	51	69
Turbocharger stay x Cylinder block	600	43	59
Oxygen sensor x Turbine outlet elbow	450	33	44

## EFI SYSTEM (5S-FE)

## Specifications

Fuel pressure regulator	Fuel pressure at No vacuum	2.7 – 3.1 kg/cm <sup>2</sup> (38 – 44 psi, 265 – 304 kPa)		
Cold start injector	Resistance Fuel leakage	2 – 4 Ω One drop or less per minute		
Injector	Resistance Injection volume Difference between each injector Fuel leakage	Approx. 13.8 Ω 48 – 58 cc (2.9 – 3.5 cu in.)/15 sec. 5 cc (0.31 cu in.) or less One drop or less per minute		
Throttle body	Throttle body fully closed angle	6°		
Throttle position sensor (w/o ECT)	Throttle opening angle (from Vertical)	Clearance between stop screw and lever	IDL – E1	PSW – E1
	–	0.50 mm 0.020 in.	Continuity	No continuity
	–	0.90 mm 0.035 in.	No continuity	No continuity
	Throttle valve fully opened	–	No continuity	Continuity
	51°	–	No continuity	No continuity
61°	–	No continuity	Continuity	
7.5° or less	–	Continuity	No continuity	
Throttle position sensor (w/ ECT)	Clearance between stop screw and lever		Between terminals	Resistance
	0 mm	0 in.	VTA – E2	0.2 – 0.8 kΩ
	0.50 mm	0.020 in.	IDL – E2	2.3 kΩ or less
	0.70 mm	0.028 in.	IDL – E2	Infinity
	Throttle valve fully opened position	–	VTA – E2 VC – E2	3.3 – 10 kΩ 3 – 7 kΩ
ISC valve	Resistance +B – ISCC or ISCO	19.3 – 22.3 Ω		
Cold start injector time switch	Resistance STA – E1 below 30°C (86°F)	20 – 40 Ω		
	above 40°C (104°F)	40 – 60 Ω		
	Resistance STA – Ground	20 – 80 Ω		
Water temp. sensor	Resistance at –20°C (–4°F)	10 – 20 kΩ		
	at 0°C (32°F)	4 – 7 kΩ		
	at 20°C (68°F)	2 – 3 kΩ		
	at 40°C (104°F)	0.9 – 1.3 kΩ		
	at 60°C (140°F)	0.4 – 0.7 kΩ		
	at 80°C (176°F)	0.2 – 0.4 kΩ		
Throttle opener setting speed	1,300 – 1,500 rpm			
Fuel cut rpm	w/ Vehicle speed 0 km/h and coolant temp. 80°C (176°F)			
	Fuel cut rpm	1,700 rpm		
	Fuel return rpm	1,100 rpm		

## Specifications (Cont'd)

ECU			
HINT:			
<ul style="list-style-type: none"> <li>● Perform all voltage and resistance measurements with the ECU connected.</li> <li>● Verify that the battery voltage is 11 V or above with the ignition switch is ON.</li> </ul>			
Voltage			
Terminals	Condition		STD voltage (V)
+B +B1 - E1	IG SW ON		10 - 14
BATT - E1	-		10 - 14
*1IDL - E1	IG SW ON	Throttle valve open	8 - 14
*1PSW - E1		Throttle valve fully closed (Throttle opener must be cancelled first)	4 - 6
*2IDL - E2		Throttle valve open	8 - 14
*2VTA - E2		Throttle valve fully closed (Throttle opener must be cancelled first)	0.1 - 1.0
		Throttle valve open	4 - 5
VC - E2		-	4 - 6
PIM - E2		-	2.5 - 4.5
No.10 - E01 No.20 - E02		IG SW ON	
THA - E2	IG SW ON	Intake air temp. 20°C (68°F)	1 - 3
THW - E2		Coolant temp. 80°C (176°F)	0.1 - 1.0
STA - E1	Cranking		6 - 14
IGT - E1	Cranking or idling		0.7 - 1.0
ISCC ISCO - E1	IG SW ON	Engine (and ECT) ECU connectors disconnected	8 - 14
W - E1	No trouble ("CHECK" engine warning light off) and engine running		10 - 14
*3A/C - E1	IG SW ON	Air conditioning ON	8 - 14
T - E1		Check connector TE1 - E1 not connected	10 - 14
		Check connector TE1 - E1 connected	1 or less
*4NSW - E1		Shift position P or N range	0 - 2
		Ex. shift position P or N range	6 - 14
B/K - E1		Stop light SW ON (Brake pedal depressed)	

\*1w/o ECT \*2w/ ECT \*3w/ A/C \*4w/ A/T

## Specifications (Cont'd)

ECU (cont'd)	Resistance		
	Terminals	Condition	STD resistance ( $\Omega$ )
* <sup>1</sup> IDL - E1		Throttle valve open	Infinity
		Throttle valve fully closed (Throttle opener must be cancelled first)	0
* <sup>1</sup> PSW - E1		Throttle valve fully open	0
		Throttle valve fully closed (Throttle opener must be cancelled first)	Infinity
* <sup>2</sup> IDL - E2		Throttle valve open	Infinity
		Throttle valve fully closed (Throttle opener must be cancelled first)	2,300 or less
* <sup>2</sup> VTA - E2		Throttle valve fully open	3,300 - 10,000
		Throttle valve fully closed (Throttle opener must be cancelled first)	200 - 800
VC - E2		-	3,000 - 7,000
THA - E2		Intake air temp. 20°C (68°F)	2,000 - 3,000
THW - E2		Coolant temp. 80°C (176°F)	200 - 400
G NE - G $\ominus$		-	170 - 210
ISCC - +B ISCO - +B1		-	19.3 - 22.3

\*<sup>1</sup>w/o ECT \*<sup>2</sup>w/ ECT

## Torque Specifications

Part tightened		kg-cm	ft-lb	N·m
Fuel line	Union bolt type	300	22	29
	Flare nut type	385	28	38
Fuel pump x Fuel tank		40	35 in.-lb	3.9
Cold start injector x Air intake chamber		95	82 in.-lb	9.3
Cold start injector pipe x Cold start injector		180	13	18
Cold start injector pipe x Delivery pipe		180	13	18
Fuel pressure regulator x Delivery pipe		55	48 in.-lb	5.4
Fuel return pipe x Fuel pressure regulator		180	13	18
Delivery pipe x Cylinder head		130	9	13
Throttle body x Air intake chamber		195	14	19

## EFI SYSTEM (3S-GE)

## Specifications

Fuel pressure regulator	Fuel pressure at No vacuum	2.7 – 3.1 kg/cm <sup>2</sup> (38 – 44 psi, 265 – 304 kPa)	
Cold start injector	Resistance Fuel leakage	2 – 4 Ω One drop or less per minute	
Injector	Resistance Injection volume Difference between each injector Fuel leakage	Approx. 13.8 Ω 66 – 82 cc (4.0 – 5.0 cu in.) per 15 sec. 5 cc (0.3 cu in.) or less One drop or less per minute	
Throttle body	Throttle body fully closed angle	6°	
Throttle position sensor	Clearance between stop screw and lever	Between terminals	Resistance
	0 mm      0 in. 0.50 mm    0.020 in. 0.70 mm    0.028 in. Throttle valve fully opened position –	VTA – E2 IDL – E2 IDL – E2 VTA – E2 VC – E2	0.2 – 0.8 kΩ 2.3 kΩ or less Infinity 3.3 – 10 kΩ 3 – 7 kΩ
ISC valve	Resistance +B – RSC or RSO	19.3 – 22.3 Ω	
Cold start injector time switch	w/o TWC Resistance STA – E1 below 15°C (59°F) above 30°C (86°F) STA – Ground	25 – 45 Ω 65 – 85 Ω 25 – 85 Ω	
	w/ TWC Resistance STA – STJ below 10°C (50°F) above 25°C (77°F) STA – Ground	30 – 50 Ω 70 – 90 Ω 30 – 90 Ω	
Water temp. sensor	Resistance at –20°C (–4°F) at 0°C (32°F) at 20°C (68°F) at 40°C (104°F) at 60°C (140°F) at 80°C (176°F)	10 – 20 kΩ 4 – 7 kΩ 2 – 7 kΩ 0.9 – 1.3 kΩ 0.4 – 0.7 kΩ 0.2 – 0.4 kΩ	
Oxygen sensor	Heater coil resistance	5.1 – 6.3 Ω	
ACIS VSV	Resistance	33 – 39 Ω	
Fuel pressure VSV	Resistance	33 – 39 Ω	
Fuel cut rpm	w/ Vehicle speed 0 km/h and coolant temp. 80°C (176°F) Fuel cut rpm      2,000 rpm Fuel return rpm    1,700 rpm		



## Specifications (Cont'd)

ECU		HINT:	
		<ul style="list-style-type: none"> <li>● Perform all voltage and resistance measurements with the ECU connected.</li> <li>● Verify that the battery voltage is 11 V or above with the ignition switch is ON.</li> </ul>	
Voltage			
Terminals	Condition		STD voltage (V)
+B +B1 - E1	IG SW ON		10 - 14
BATT - E1	-		10 - 14
IDL - E2	IG SW ON	Throttle valve open	4 - 6
VTA - E2		Throttle valve fully closed	0.1 - 1.0
VC - E2		Throttle valve open	4 - 5
PIM - E2		-	4 - 6
		-	2.5 - 4.5
No.1 No.2 - E01 No.3 - E02 No.4	IG SW ON		10 - 14
THA - E2	IG SW ON	Intake air temp. 20°C (68°F)	1 - 3
THW - E2		Coolant temp. 80°C (176°F)	0.1 - 1.0
STA - E1	Cranking		6 - 14
IGT - E1	Cranking or idling		0.7 - 1.0
RSC RSO - E1	IG SW ON	Engine (and ECT) ECU connectors disconnected	8 - 14
W - E1	No trouble ("CHECK" engine warning light off) and engine running		10 - 14
*1AC1 - E1	IG SW ON	Air conditioning ON	8 - 14
ACIS - E1	Idling		2.0 or less
	5,100 rpm or more		10 - 14
T - E1	IG SW ON	Check connector TE1 - E1 not connected	10 - 14
		Check connector TE1 - E1 connected	1 or less
*2NSW - E1		Shift position P or N range	0 - 2
		Ex. shift position P or N range	6 - 14

\*1w/ A/C \*2w/ ECT

**Specifications (Cont'd)**

ECU (cont'd)	Resistance		
	Terminals	Condition	STD resistance ( $\Omega$ )
IDL - E2		Throttle valve open	Infinity
		Throttle valve fully closed	2,300 or less
VTA - E2		Throttle valve fully open	3,500 - 10,000
		Throttle valve fully closed	200 - 800
VC - E2		-	3,000 - 7,000
THA - E2		Intake air temp. 20°C (68°F)	2,000 - 3,000
THW - E2		Coolant temp. 80°C (176°F)	200 - 400
G1 G2 - G $\ominus$		-	140 - 180
NE - G $\ominus$		-	180 - 220
RSC +B RSO - +B1		-	19.3 - 22.3

**Torque Specifications**

Part tightened	kg-cm	ft-lb	N·m	
Fuel line	Union bolt type	300	22	29
		385	28	38
Fuel pump x Fuel tank	Flare nut type	40	35 in.-lb	3.9
		60	52 in.-lb	5.9
Cold start injector x Air intake chamber		180	13	18
Cold start injector pipe x Cold start injector		180	13	18
Cold start injector pipe x Delivery pipe		300	22	29
Fuel pressure regulator x Delivery pipe		180	13	18
Fuel return pipe x Fuel pressure regulator		195	14	19
Delivery pipe x Cylinder head		195	14	19
Throttle body x Air intake chamber		195	14	19
Air intake chamber x Intake air control valve		400	29	39
Air intake chamber x Intake pipe stay				



## Specifications (Cont'd)

ECU		HINT:	
		<ul style="list-style-type: none"> <li>● Perform all voltage and resistance measurements with the ECU connected.</li> <li>● Verify that the battery voltage is 11 V or above with the ignition switch is ON.</li> </ul>	
Voltage			
Terminals	Condition		STD voltage (V)
+B +B1 - E1	IG SW ON		10 - 14
BATT - E1	-		10 - 14
IDL - E2	IG SW ON	Throttle valve open	4 - 6
VTA - E2		Throttle valve fully closed	0.1 - 1.0
		Throttle valve open	4 - 5
VC - E2		-	4 - 6
VS - E2		Measuring plate fully closed	3.7 - 4.3
		Measuring plate fully open	0.2 - 0.5
	Idling	2.3 - 3.8	
		3,000 rpm	1.0 - 2.0
No.1 No.2 - E01 No.3 - E02 No.4	IG SW ON		10 - 14
THA - E2	IG SW ON	Intake air temp. 20°C (68°F)	1 - 3
THW - E2		Coolant temp. 80°C (176°F)	0.1 - 1.0
STA - E1	Cranking		6 - 14
IGT - E1	Cranking or idling		0.7 - 1.0
RSC RSO - E1	IG SW ON	Engine ECU connectors disconnected	8 - 14
W - E1	No trouble ("CHECK" engine warning light off) and engine running		10 - 14
PIM - E2	IG SW ON		2.5 - 4.5
*1AC1 - E1	IG SW ON	Air conditioning ON	8 - 14
*2T-VIS - E1		Throttle valve fully closed	2.0 or less
		Throttle valve open	10 - 14
*3T-VIS - E1	Idling		2.0 or less
	4,200 rpm or more		10 - 14
T - E1	IG SW ON	Check connector T - E1 not connected	10 - 14
		Check connector T - E1 connected	1 or less

\*1w/ A/C \*2w/ Regular Unleaded Gasoline \*3w/ Premium Unleaded Gasoline

## Specifications (Cont'd)

ECU (cont'd)	Resistance		
	Terminals	Condition	STD resistance ( $\Omega$ )
IDL - E2		Throttle valve open	Infinity
		Throttle valve fully closed	2,300 or less
VTA - E2		Throttle valve fully open	3,500 - 10,000
		Throttle valve fully closed	200 - 800
VC - E2		-	200 - 400
VS - E2		Measuring plate fully closed	200 - 600
		Measuring plate fully open	20 - 1,200
THA - E2		Intake air temp. 20°C (68°F)	2,000 - 3,000
THW - E2		Coolant temp. 80°C (176°F)	200 - 400
G1 G2 - G $\ominus$		-	140 - 180
NE - G $\ominus$		-	180 - 220
RSC +B RSO +B1		-	19.3 - 22.3

## Torque Specifications

Part tightened		kg-cm	ft-lb	N-m
Fuel line	Union bolt type	300	22	29
	Flare nut type	385	28	38
Fuel pump x Fuel tank		30	26 in.-lb	2.9
Fuel inlet pipe x Fuel tank		30	26 in.-lb	2.9
Cold start injector x Intake manifold (Air intake chamber)		60	52 in.-lb	5.9
Cold start injector pipe x Cold start injector		180	13	18
Cold start injector pipe x Delivery pipe		180	13	18
Fuel pressure regulator x Delivery pipe		300	22	29
Delivery pipe x Cylinder head		195	14	19
Fuel inlet hose x Delivery pipe		300	22	29
Throttle body x Intake manifold (Air intake chamber)		195	14	19
Air connector stay x Throttle body		195	14	19
Air connector stay x Cylinder head		80	69 in.-lb	7.8
Air connector x Throttle body		195	14	19

**COOLING SYSTEM****Specifications**

Engine coolant capacity		See page A-2 or 6
Radiator cap	Relief valve opening pressure	STD 0.75 – 1.05 kg/cm <sup>2</sup> (10.7 – 14.9 psi, 74 – 103 kPa)
	Limit	0.6 kg/cm <sup>2</sup> 8.5 psi      59 kPa
Thermostat	Valve opening temperature	80 – 84°C      176 – 183°F
	Valve lift at 95°C (203°F)	8 mm (0.31 in.) or more

**Torque Specifications**

Part tightened	kg-cm	ft-lb	N·m
Engine coolant x Drain plug	130	9	13
Water pump x Water pump cover	95	82 in.-lb	9.3
Water pump x Cylinder block	95	82 in.-lb	9.3
Water by-pass pipe x Water pump	95	82 in.-lb	9.3
Water inlet x Water pump	90	78 in.-lb	8.8

**LUBRICATION SYSTEM****Specifications**

Engine oil capacity		See page A-2 or 6	
	at idling at 3,000 rpm	0.3 kg/cm <sup>2</sup> (4.3 psi, 29 kPa) or more 2.5 – 5.0 kg/cm <sup>2</sup> (36 – 71 psi, 245 – 490 kPa)	
Oil pump	Body clearance	STD	0.10 – 0.16 mm      0.0039 – 0.0063 in.
		Limit	0.20 mm      0.0079 in.
	Tip clearance	STD	0.04 – 0.16 mm      0.0016 – 0.0063 in.
		Limit	0.20 mm      0.0079 in.

**Torque Specifications**

Part tightened	kg-cm	ft-lb	N·m	
Engine oil drain plug	250	18	25	
Oil pump body cover x Oil pump body	90	78 in.-lb	8.8	
Oil pump x Cylinder block	80	69 in.-lb	7.8	
Oil strainer x Cylinder block	55	48 in.-lb	5.4	
Oil strainer x Oil pump	55	48 in.-lb	5.4	
Oil pan x Cylinder block	55	48 in.-lb	5.4	
Oil pan x Oil pump	55	48 in.-lb	5.4	
Stiffener plate x Cylinder block	380	27	37	
Oil cooler x Cylinder block (5S-FE, 3S-GE)	Relief valve Bolt	800	58	78
		80	69 in.-lb	7.8
Oil cooler x Oil cooler bracket (3S-GTE)	800	58	78	
Oil cooler bracket x Cylinder block (3S-GTE)	80	69 in.-lb	7.8	
Oil nozzle x Cylinder block (3S-GTE)	93	81 in.-lb	9.1	

**IGNITION SYSTEM**

Firing order		1 - 3 - 4 - 2	
Spark plug		See page A-2 or 6	
High-tension cord	Resistance	25 k $\Omega$ per cord	
Ignition coil	Primary coil resistance	0.40 - 0.50 $\Omega$	
	Secondary coil resistance	10.2 - 13.8 k $\Omega$	
Distributor	Air gap	0.2 - 0.4 mm	0.008 - 0.016 in.
	Signal generator (pickup coil) resistance		
	5S-FE	170 - 210 $\Omega$	
	3S-GE, 3S-GTE G1 to G $\ominus$	140 - 180 $\Omega$	
	G2 to G $\ominus$	140 - 180 $\Omega$	
	NE to G $\ominus$	180 - 220 $\Omega$	

**STARTING SYSTEM**

Starter	Rated voltage and output power		12 V 1.0 kW		12 V 1.4 kW	
	No-load characteristic	Current	90 A or less at 11.5 V		←	
		rpm	3,000 rpm or more		3,500 rpm or more	
	Brush length	STD	13.5 mm	0.531 in.	15.5 mm	0.610 in.
		Limit	8.5 mm	0.335 in.	10.0 mm	0.394 in.
	Commutator	Outer diameter	STD	30 mm	1.18 in.	←
			Limit	29 mm	1.14 in.	←
		Undercut depth	STD	0.6 mm	0.024 in.	←
			Limit	0.2 mm	0.008 in.	←
	Circle runout	Limit	0.05 mm	0.0020 in.	←	
Spring installed load	STD	1.79 - 2.41 kg (3.9 - 5.3 lb, 17 - 24 N)		←		

**CHARGING SYSTEM**

Drive belt tension		See page A-2 or 6		
Battery specific gravity When fully charged at 20°C (68°F)		1.25 - 1.27		
Alternator	Rated output	12 V - 70 A		
	Rotor coil resistance	2.8 - 3.0 $\Omega$		
	Slip ring diameter	STD	14.2 - 14.4 mm	0.559 - 0.567 in.
		Limit	12.8 mm	0.504 in.
	Brush exposed length	STD	10.5 mm	0.413 in.
Limit		1.5 mm	0.059 in.	
Alternator regulator (IC)	Regulating voltage	at 25°C (77°F)	13.9 - 15.1 V	
		at 115°C (239°F)	13.5 - 14.3 V	









# STANDARD BOLT TORQUE SPECIFICATIONS

	Page
STANDARD BOLT TORQUE SPECIFICATIONS .....	B-2

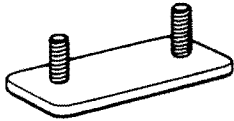

# STANDARD BOLT TORQUE SPECIFICATIONS

## HOW TO DETERMINE BOLT STRENGTH

	Mark	Class		Mark	Class
Hexagon head bolt	 <p>Bolt head No.</p> <p>4— 4T 5— 5T 6— 6T 7— 7T 8— 8T 9— 9T 10— 10T 11— 11T</p>		Stud bolt	 <p>No mark</p>	4T
Hexagon flange bolt w/ washer hexagon bolt	 <p>No mark</p>	4T		 <p>Grooved</p>	6T
Hexagon head bolt	 <p>Two protruding lines</p>	5T			
Hexagon flange bolt w/ washer hexagon bolt	 <p>Two protruding lines</p>	6T	Welded bolt		4T
Hexagon head bolt	 <p>Three protruding lines</p>	7T			
Hexagon head bolt	 <p>Four protruding lines</p>	8T			

## SPECIFIED TORQUE FOR STANDARD BOLTS









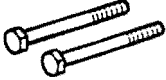

Class	Diameter mm	Pitch mm	Specified torque					
			Hexagon head bolt			Hexagon flange bolt		
			kg-cm	ft-lb	N-m	kg-cm	ft-lb	N-m
4T	6	1	55	48 in.-lb	5	60	52 in.-lb	6
	8	1.25	130	9	12.5	145	10	14
	10	1.25	260	19	26	290	21	29
	12	1.25	480	35	47	540	39	53
	14	1.5	760	55	74	850	61	84
	16	1.5	1,150	83	115	—	—	—
5T	6	1	65	56 in.-lb	6.5	75	65 in.-lb	7.5
	8	1.25	160	12	15.5	175	13	17.5
	10	1.25	330	24	32	360	26	36
	12	1.25	600	43	59	670	48	65
	14	1.5	930	67	91	1,050	76	100
	16	1.5	1,400	101	140	—	—	—
6T	6	1	80	69 in.-lb	8	90	78 in.-lb	9
	8	1.25	195	14	19	210	15	21
	10	1.25	400	29	39	440	32	44
	12	1.25	730	53	71	810	59	80
	14	1.5	1,100	80	110	1,250	90	125
	16	1.5	1,750	127	170	—	—	—
7T	6	1	110	8	10.5	120	9	12
	8	1.25	260	19	25	290	21	28
	10	1.25	530	38	52	590	43	58
	12	1.25	970	70	95	1,050	76	105
	14	1.5	1,500	108	145	1,700	123	165
	16	1.5	2,300	166	230	—	—	—
8T	8	1.25	300	22	29	330	24	33
	10	1.25	620	45	61	690	50	68
	12	1.25	1,100	80	110	1,250	90	120
9T	8	1.25	340	25	34	380	27	37
	10	1.25	710	51	70	790	57	78
	12	1.25	1,300	94	125	1,450	105	140
10T	8	1.25	390	28	38	430	31	42
	10	1.25	800	58	78	890	64	88
	12	1.25	1,450	105	140	1,600	116	155
11T	8	1.25	430	31	42	480	35	47
	10	1.25	890	64	87	990	72	97
	12	1.25	1,600	116	155	1,800	130	175

# SST AND SSM

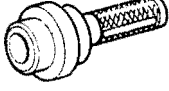
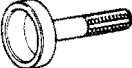



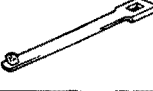

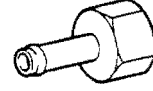



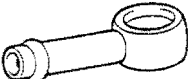
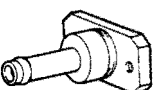

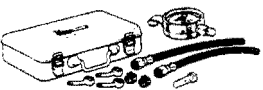
	<b>Page</b>
<b>SST (SPECIAL SERVICE TOOLS)</b> .....	<b>C-2</b>
<b>SSM (SPECIAL SERVICE MATERIALS)</b> .....	<b>C-6</b>

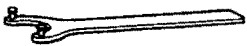

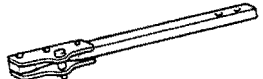



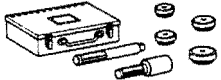

## SST (SPECIAL SERVICE TOOLS) (Cont'd)

Section	Part Name	EM	TC	FI	LU	IG	ST	CH	Note
Part No.	Illustration								
(09213-00050)	 (Bolt Set)	●							5S-FE only
09216-00020	 Belt Tension Gauge							●	
09216-00030	 Belt Tension Gauge Cable							●	
09222-30010	 Connecting Rod Bushing Remover & Replacer	●							
09223-46011	 Crankshaft Front Oil Seal Replacer	●							Camshaft oil seal for 5S-FE
09223-50010	 Crankshaft Front Oil Seal Replacer	●							Camshaft oil seal for 3S-GE and 3S-GTE
09223-63010	 Crankshaft Rear Oil Seal Replacer	●							
09226-10010	 Crankshaft Front & Rear Bearing Replacer	●							Crankshaft front oil seal
09228-06500	 Oil Filter Wrench				●				
09240-00020	 Wire Gauge Set					●			
09248-55010	 Valve Clearance Adjust Tool Set	●							
09249-63010	 Torque Wrench Adaptor	●							
09268-41045	 Injection Measuring Tool Set			●					
(09268-41060)	 (No. 3 Union)			●					3S-GE only

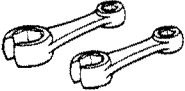
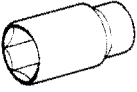
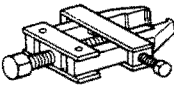
## SST (SPECIAL SERVICE TOOLS) (Cont'd)

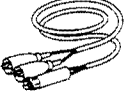
Section	Part Name	Part No.	Illustration	EM	TC	FI	LU	IG	ST	CH	Note
		(09268-41080)				●					
		(09268-41090)				●					5S-FE only
		(90405-09015)				●					
		09268-45012				●					
		09268-74010				●					3S-GTE only
		09278-54012		●							Camshaft timing pulley for 5S-FE
		09285-76010				∩			● *1	● *2	*1 Starter front bearing for 1.0 kW type *2 Rotor rear bearing
		09286-46011							● *1	● *2	*1 Starter bearing *2 Rectifier end frame
		09330-00021		●							Crankshaft pulley
		09608-20012								●	
		(09608-00030)								●	Rotor front bearing
		09616-30011		●							Oil pump pulley
		09620-30010					●				
		(09627-30010)					●				Oil pump oil seal

## SST (SPECIAL SERVICE TOOLS) (Cont'd)

Section	Part Name	Part No.	Illustration	EM	TC	FI	LU	IG	ST	CH	Note
		(09631-00020)					●				Oil pump oil seal
		09631-22020				●					Fuel line flare nut
		09816-30010		● *1			● *2				*1 Knock sensor for 3S-GE and 3S-GTE *2 3S-GTE only
		09820-00021								●	
		09820-63010								●	
		09842-30050				●					
		09842-30060				●					3S-GTE only
		09842-30070				●					5S-FE and 3S-GE
		09843-18020		●		●					
		09992-00241			●						

**SSM (SPECIAL SERVICE MATERIALS)**

Part Name	Part No.	Sec.	Use etc.
Seal packing or equivalent	08826-00080	EM	Cylinder head semi-circular plug for 5S-FE Camshaft bearing cap Cylinder head cover
		LU	Oil pan
Adhesive 1324, Three bond 1324 or equivalent	08833-00070	EM	Flywheel mount bolt for M/T Drive plate mount bolt for A/T
Adhesive 1344, Three bond 1344, Loctite 242 or equivalent	08833-00080	EM	No.1 idler pulley
		LU	Oil pressure switch